

# LAND PLANES

**| LP1-60**

**| LP1-72**

**| LP1-84**

**| LP1-96**

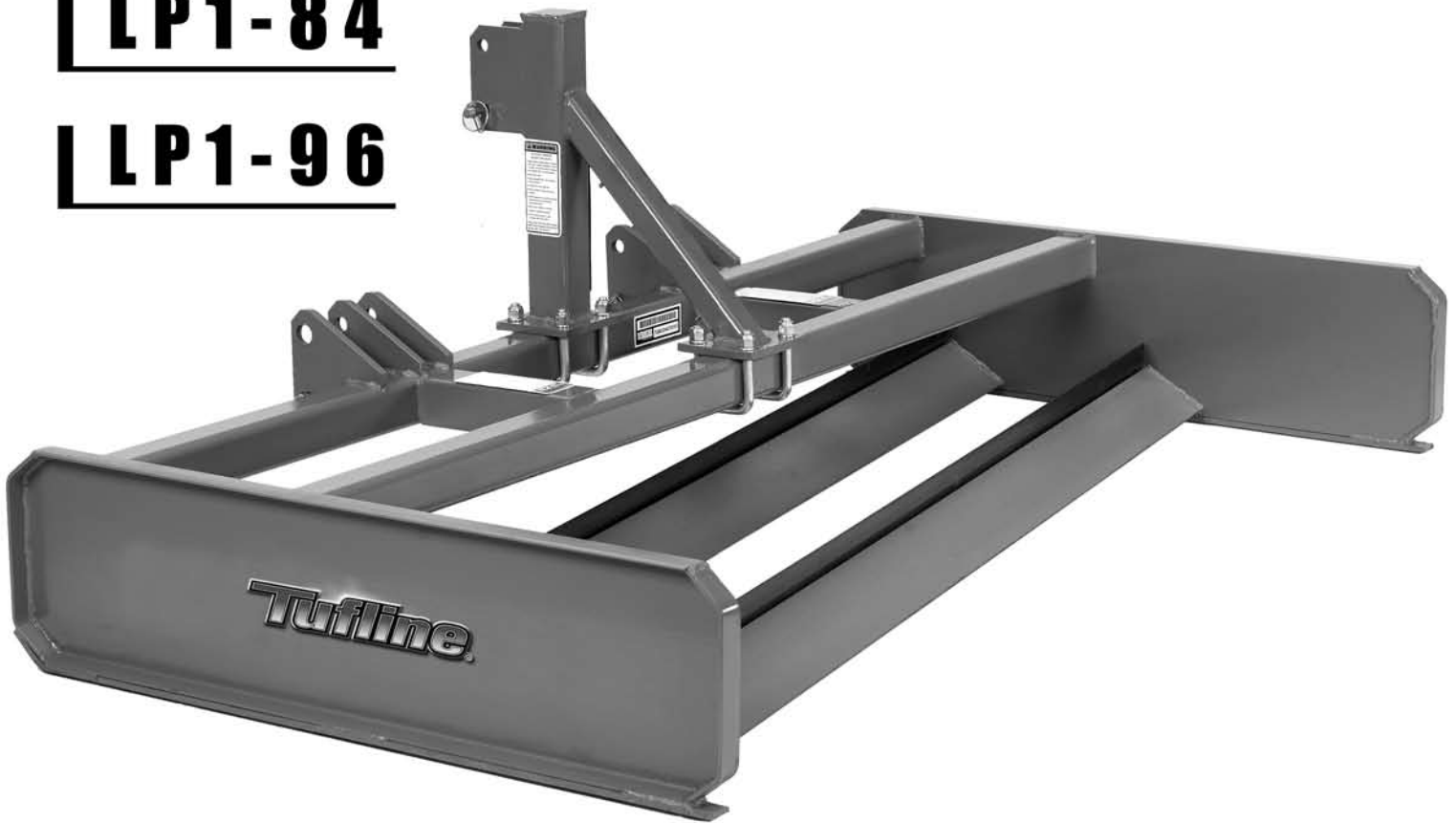

***Tufline***  
Well Built, Performance Driven Implements

## TO THE DEALER:

Assembly and proper installation of this product is the responsibility of the Frontier dealer. Read manual instructions and safety rules. Make sure all items on the Dealer's Pre-Delivery and Delivery Check Lists in the Owner's/Operator's Manual are completed before releasing equipment to the owner.

The dealer must complete the Warranty Registration located on the Frontier website.

## TO THE OWNER:

Read this manual before operating your Frontier equipment. The information presented will prepare you to do a better and safer job. Keep this manual handy for ready reference. Require all operators to read this manual carefully and become acquainted with all the adjustment and operating procedures before attempting to operate. Replacement manuals can be obtained from your Frontier dealer.

The equipment you have purchased has been carefully engineered and manufactured to provide dependable and satisfactory use. Like all mechanical products, it will require cleaning and upkeep. Lubricate the unit as specified. Observe all safety information in this manual and safety decals on the equipment.

For service, your authorized Frontier dealer has trained mechanics, genuine Frontier service parts, and the necessary tools and equipment to handle all your needs.

Use only genuine Frontier service parts. Substitute parts will void the warranty and may not meet standards required for safe and satisfactory operation. Record the model number and serial number of your equipment in the spaces provided:

**Model:** \_\_\_\_\_ **Date of Purchase:** \_\_\_\_\_

**Serial Number:** (see Safety Decal section for location) \_\_\_\_\_

Provide this information to your dealer to obtain correct repair parts.

Throughout this manual, the term **IMPORTANT** is used to indicate that failure to observe can cause damage to equipment. The terms **CAUTION**, **WARNING** and **DANGER** are used in conjunction with the Safety-Alert Symbol, (a triangle with an exclamation mark), to indicate the degree of hazard for items of personal safety.



This Safety-Alert Symbol indicates a hazard and means **ATTENTION! BECOME ALERT! YOUR SAFETY IS INVOLVED!**

### **DANGER**

Indicates an imminently hazardous situation that, if not avoided, will result in death or serious injury.

### **WARNING**

Indicates a potentially hazardous situation that, if not avoided, could result in death or serious injury, and includes hazards that are exposed when guards are removed.

### **CAUTION**

Indicates a potentially hazardous situation that, if not avoided, may result in minor or moderate injury.

### **IMPORTANT NOTE**

Indicates that failure to observe can cause damage to equipment.

Indicates helpful information.

# TABLE OF CONTENTS

INTRODUCTION . . . . .	ii
SPECIFICATIONS / GENERAL INFORMATION . . . . .	1
SAFETY DECALS . . . . .	2 - 3
SAFETY RULES . . . . .	4 - 6
DEALER INSTRUCTIONS . . . . .	7
OPERATION . . . . .	8 - 9
OWNER SERVICE . . . . .	10
PARTS CATALOG . . . . .	11 - 12
BOLT SIZE AND BOLT TORQUE CHART . . . . .	13
WARRANTY . . . . .	14
WARRANTY FOR PARTS . . . . .	15

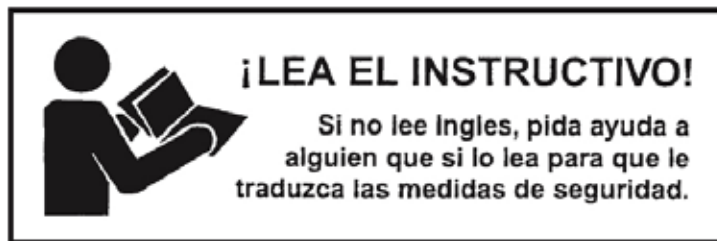

# SPECIFICATIONS

	<b>LP1160</b>	<b>LP1172</b>	<b>LP1184</b>	<b>LP1196</b>
3-Point Hitch	Category I (iMatch Compatible)	Category I (iMatch Compatible)	Category I and II Quick Hitch (iMatch Compatible)	Category I and II Quick Hitch (iMatch Compatible)
Working Width	60"	72"	84"	96"
Working Depth	48"	48"	48"	48"
Tractor HP	18-50 HP	18-50 HP	22-75 HP	22-75 HP
Shipping Weight	573 lbs	628 lbs	684 lbs	732 lbs
Approximate Operating Weight	493 lbs	548 lbs	604 lbs	652 lbs
Beam Type	Tubular 3" X 3" X 1/4"	Tubular 3" X 3" X 1/4"	Tubular 3" X 3" X 1/4"	Tubular 3" X 3" X 1/4"
Cutting Edges	(2) 1/2" x 6' Reversible	(2) 1/2" x 6' Reversible	(2) 1/2" x 6' Reversible	(2) 1/2" x 6' Reversible
Skid Plate Thickness	3/8"	3/8"	3/8"	3/8"
End Plate Thickness	3/16"	3/16"	3/16"	3/16"
End Plate Height	12"	12"	12"	12"

## GENERAL INFORMATION

The purpose of this manual is to assist you in operating and maintaining your Land Plane. Read it carefully. It furnishes information and instructions that will help you achieve years of dependable performance.

These instructions have been compiled from field experience and engineering data. Some information may be general in nature, due to unknown and varying operating conditions. However, through experience and these instructions, you should be able to develop procedures suitable to

your particular situation.

The illustrations and data used in this manual were current at the time of printing. However, due to possible inline production changes, your machine may vary slightly in detail. We reserve the right to redesign and change the machines as may be necessary without notification.

Throughout this manual, references are made to right and left direction. These are determined by standing behind the tractor facing the direction of forward travel.

# SAFETY & INSTRUCTIONAL DECALS

**ATTENTION! BECOME ALERT! YOUR SAFETY IS INVOLVED!**

**FAILURE TO FOLLOW THESE INSTRUCTIONS COULD RESULT IN SERIOUS INJURY OR DEATH**

**Replace Decals Immediately If Damaged!**

Check that all safety decals are installed and in good condition. Replace if decals are worn or damaged. Replacement Part numbers are listed here.

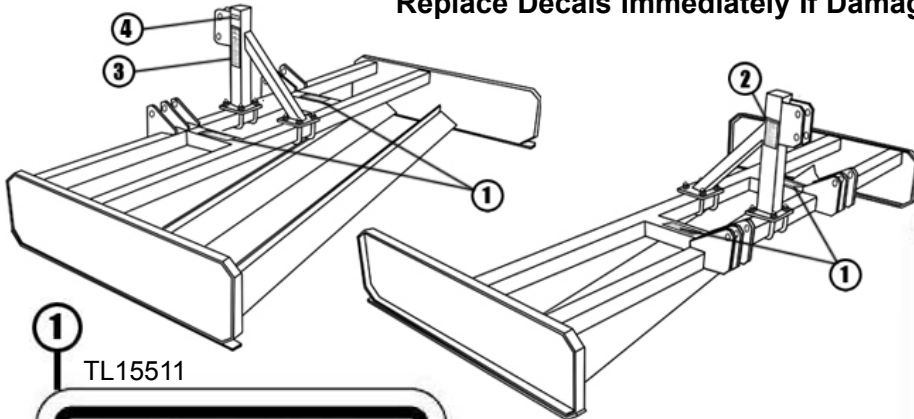

1 TL15511

**WARNING**

**CRUSHING AND PINCHING HAZARD**

- Be extremely careful handling various parts of the machine. They are extremely heavy and hands, fingers, feet and other body parts could be crushed or pinched between tractor and implement.
- Operate tractor controls from tractor seat only.
- Do not stand between tractor and implement when tractor is in gear.
- Make sure parking brake is engaged before going between tractor and implement.
- Stand clear of machine when in operation or when it is being raised or lowered.

TL15511A

2 TL15511

**WARNING**

**TO AVOID SERIOUS INJURY OR DEATH:**

- Read Operator's Manual before operating, servicing or repairing equipment. Follow all safety rules and instructions. Manuals are available from your selling dealer.
- Never allow riders.
- Keep bystanders away from equipment during operation.
- Operate from tractor seat only.
- Lower equipment to ground, stop engine, remove key and set brake before dismounting tractor.
- Never allow children or untrained persons to operate equipment.
- Do not operate towed or semi-mounted units over 20 MPH.

**FAILURE TO FOLLOW THESE INSTRUCTIONS CAN RESULT IN INJURY OR DEATH.**

TL15511B

3 TL15511

**WARNING**

**FALLING OFF CAN RESULT IN BEING RUN OVER.**

- Tractor must be equipped with ROPS (or ROPS CAB) and seat belt. Keep foldable ROPS systems in "locked up" position at all times.
- Buckle Up! Keep seat belt securely fastened.
- Allow no riders.

**RAISED IMPLEMENT CAN DROP AND CRUSH.**

- Never go underneath raised implement which can drop from equipment or tractor 3-point hitch hydraulic leak down, hydraulic system failures, movement of control levers or mechanical linkage failures.
- Service work does not require going underneath implement. Read manual instructions.

**FALLING OFF OR GOING UNDERNEATH IMPLEMENT CAN RESULT IN SERIOUS INJURY OR DEATH.**

TL15511C

**TUFLINE**

MODEL # \_\_\_\_\_

SERIAL # \_\_\_\_\_

**TUFLINE MANUFACTURING COMPANY, INC.**  
COLUMBUS, MS  
662-328-8347

4

Serial Number Plate

# SAFETY REFLECTOR DECALS

**ATTENTION! BECOME ALERT! YOUR SAFETY IS INVOLVED!**  
**FAILURE TO FOLLOW THESE INSTRUCTIONS COULD RESULT IN SERIOUS INJURY OR DEATH**

Replace Decals Immediately If Damaged!

Only on LP1196

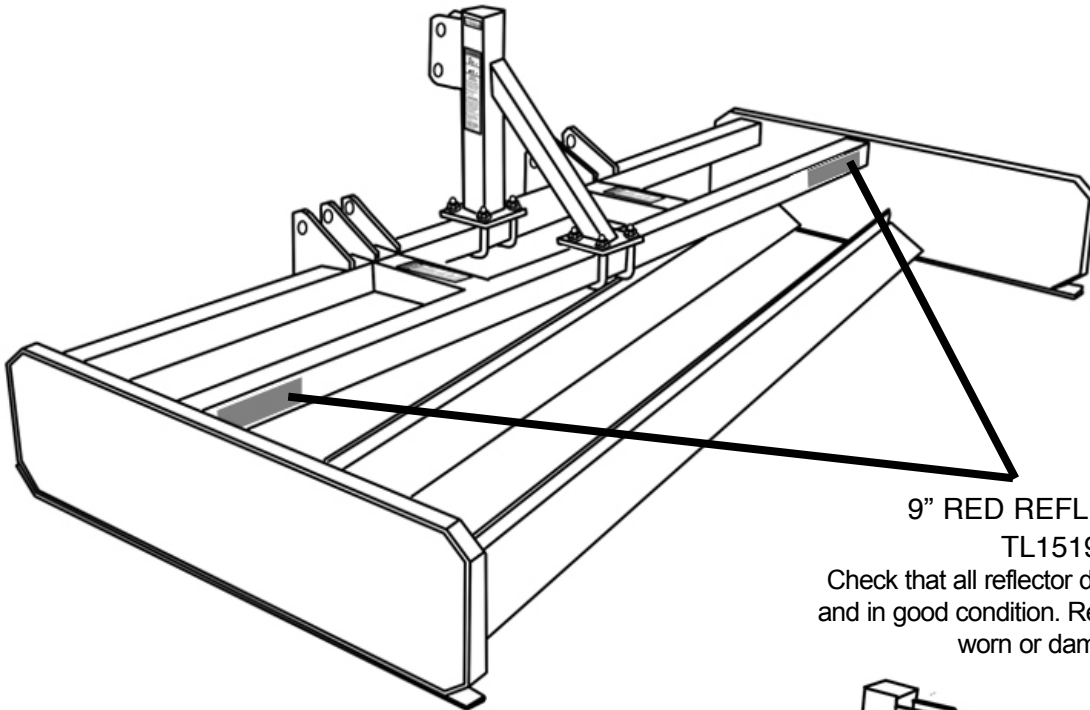

9" RED REFLECTORS

TL15199

Check that all reflector decals are installed and in good condition. Replace if decals are worn or damaged.

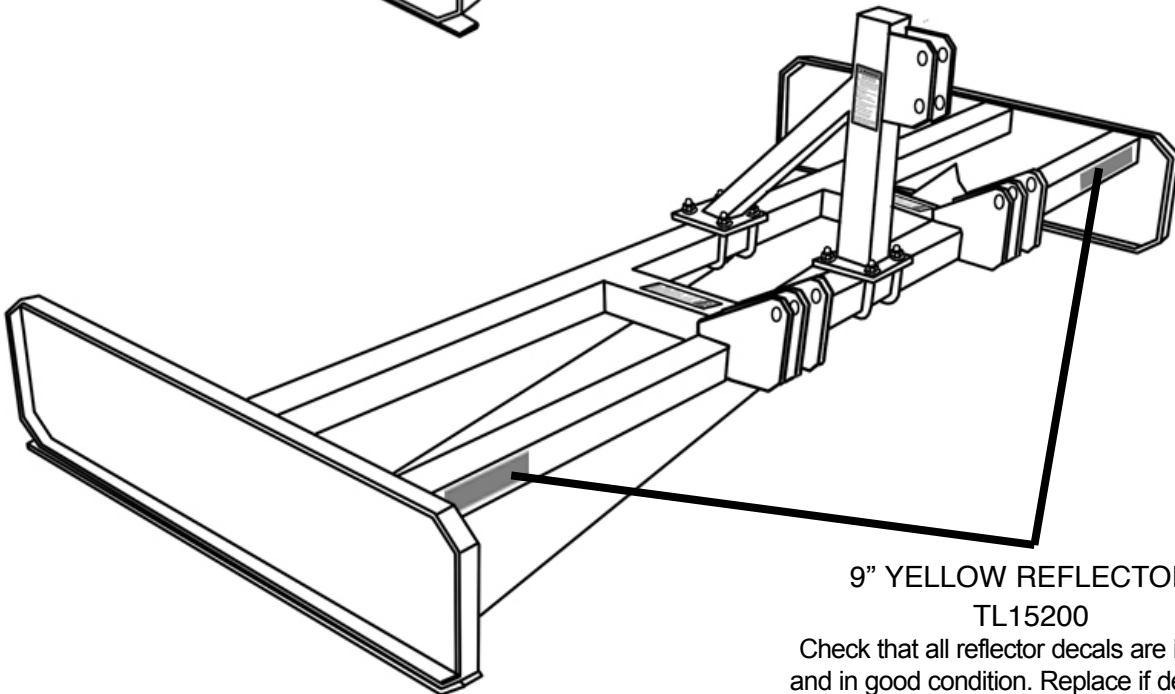

9" YELLOW REFLECTORS

TL15200

Check that all reflector decals are installed and in good condition. Replace if decals are worn or damaged.



# SAFETY RULES



ATTENTION! BECOME ALERT! YOUR SAFETY IS INVOLVED!

Safety is a primary concern in the design and manufacture of our products. Unfortunately, our efforts to provide safe equipment can be wiped out by an operator's single careless act.

In addition to the design and configuration of equipment, hazard control and accident prevention are dependent upon the awareness, concern, judgement, and proper training of personnel involved in the operation, transport, maintenance and storage of equipment.

It has been said "The best safety device is an informed, careful operator." We ask you to be that kind of operator.

## TRAINING

- Safety instructions are important! Read all attachment and power unit manuals; follow all safety rules and safety decal information. (Replacement manuals are available from selling dealer.) Failure to follow instructions or safety rules can result in serious injury or death.
- If you do not understand any part of this manual and need assistance, see your dealer.
- Operators must be instructed in and be capable of the safe operation of the equipment, its attachments, and all controls. Do not allow anyone to operate this equipment without proper instructions.
- Never allow children or untrained persons to operate equipment.
- Train all new personnel and review instruction's frequently with existing workers. A person who has not read and understood all operating and safety instructions is not qualified to operate the machine. An untrained operator exposes himself and bystanders to possible serious injury or death.

## PREPARATION

- Always wear relatively tight and belted clothing to avoid getting caught in moving parts. Wear sturdy,

rough-soled work shoes and protective equipment for eyes, hair, hands, hearing, and head; and respirator or filter mask where appropriate.

- Make sure attachment is properly secured, adjusted, and in good operating condition.
- Power unit, when applicable, must be equipped with ROPS or ROPS cab and seat belt. Keep seat belt securely fastened. Falling off power unit can result in death from being run over or crushed. Keep foldable ROPS system in "locked up" position at all times.
- A minimum 20% of tractor and equipment weight must be on the tractor front wheels when attachments are in transport position. Without this weight, tractor could tip over, causing personal injury or death. The weight may be attained with a loader, front wheel weights, ballast in tires or front tractor weights. Weigh the tractor and equipment. Do not estimate.

## TRANSPORTATION

- Always comply with all state and local laws governing highway safety and lighting and marking requirements.
- Never allow riders on power unit or attachment.
- Do not operate or transport on steep slopes.
- Use extreme care and reduce ground speed on slopes and rough terrain.
- Do not operate or transport equipment while under the influence of alcohol or drugs. Consult your doctor about operating this machine while taking prescription medications.

## OPERATION

- Never go underneath equipment (lowered to the ground or raised) unless it is properly blocked and secured. Never place any part of

*Safety Rules continued on the next page*



# SAFETY RULES



ATTENTION! BECOME ALERT! YOUR SAFETY IS INVOLVED!

*Safety Rules continued from the previous page*

## **OPERATION (cont'd)**

the body underneath equipment or between moveable parts even when the engine has been turned off. Hydraulic system leak down, hydraulic system failures, mechanical failures, or movement of control levers can cause equipment to drop or rotate unexpectedly and cause severe injury or death.

- Always comply with all state and local laws governing highway safety and lighting and marking requirements.
- Operate only in daylight or good artificial light.
- Keep bystanders away from equipment.
- Keep hands, feet, hair, and clothing away from equipment while engine is running. Stay clear of all moving parts.
- Power unit, when applicable, must be equipped with ROPS or ROPS cab and seat belt. Keep seat belt securely fastened. Falling off power unit can result in death from being run over or crushed. Keep foldable ROPS system in “locked up” position at all times.
- Never allow riders on power unit or attachment.
- Always sit in power unit seat when operating controls or starting engine. Securely fasten seat belt, place transmission in neutral, engage brake, and ensure all other controls are disengaged before starting power unit engine.
- Look down and to the rear and make sure area is clear before operating in reverse.
- Use extreme care when working close to fences, ditches, other obstructions, or on hillsides.
- Do not operate or transport on steep slopes.
- Do not stop, start, or change directions suddenly on slopes. Always operate down slopes;

never across the face.

- Use extreme care and reduce ground speed on slopes and rough terrain.
- Keep alert and watch the front as well as the rear when operating.
- Stop power unit and equipment immediately upon striking an obstruction. Turn off engine, remove key, inspect, and repair any damage before resuming operation.
- Before leaving operator’s seat, put attachment on the ground. Engage brake, stop engine, remove key, and remove seat belt.

## **MAINTENANCE**

- Always wear relatively tight and belted clothing to avoid getting caught in moving parts. Wear sturdy, rough-soled work shoes and protective equipment for eyes, hair, hands, hearing, and head; and respirator or filter mask where appropriate.
- Never go underneath equipment (lowered to the ground or raised) unless it is properly blocked and secured. Never place any part of the body underneath equipment or between moveable parts even when the engine has been turned off. Hydraulic system leak down, hydraulic system failures, mechanical failures, or movement of control levers can cause equipment to drop or rotate unexpectedly and cause severe injury or death.
- When performing maintenance or repairs make sure the equipment is in the lowered position. Failure to do so can cause serious injury or death.

*Safety Rules continued on the next page*





# SAFETY RULES



ATTENTION! BECOME ALERT! YOUR SAFETY IS INVOLVED!

*Safety Rules continued from the previous page*  
**MAINTENANCE(cont'd)**

- Make sure attachment is properly secured, adjusted, and in good operating condition.
- Before leaving operator's seat put attachment on the ground. Engage brake, stop engine, remove key, and remove seat belt.
- Never perform service or maintenance with engine running.
- Keep all persons away from operator control

area while performing adjustments, service, or maintenance.

- Tighten all bolts, nuts, and screws to torque chart specifications. Check that all cotter pins are installed securely to ensure equipment is in a safe condition before putting unit into service.

## **STORAGE**

- Block equipment securely for storage.
- Keep children and bystanders away from storage area.

# DEALER INSTRUCTIONS

## Pre-Assembly

### Top Link Mast Assembly

Reference Figure 1(Pg. 11).

The Top link mast should be centered evenly between the two inside hitch ears. Once centered, insert the four TL11139 u-bolts and fasten with the eight TLT-24 lock washers and TL15132 lock nuts.

### Dealer Checklist

(Dealer's Responsibility)

Inspect the equipment thoroughly after assembly to be certain it is set up properly before delivering it to the customer. The following check list is a reminder of points to inspect.

Check off each item if it is found satisfactory or after proper adjustment is made.

\_\_\_ Check that all safety decals are installed and in good condition. Replace if damaged.

\_\_\_ Check all bolts to be sure they are tight.

\_\_\_ Check that all cotter pins and safety pins are properly installed.

\_\_\_ It is important for the dealer to visually check and make sure all parts are in tact prior to delivery to customer.

\_\_\_ Show customer the safe, proper procedures to be used when mounting, dismounting, and storing equipment.

\_\_\_ For mounted units, add wheel weights, ballast in front tires, and/or front tractor weight to enhance front end stability. A minimum 20% of tractor and equipment gross weight must be on front tractor wheels. When adding weight to attain 20% of tractor and equipment weight on front tractor wheels, you must not exceed the ROPS weight certification. Weigh the tractor and equipment. Do not estimate!

\_\_\_ Show customer how to make adjustments.

\_\_\_ Present Owner's/Operator's Manual and request that customer and all operators read it before operating equipment. Point out the manual safety rules, explain their meanings and emphasize the increased safety hazards that exist when safety rules are not followed.

\_\_\_ Point out the safety decals. Explain their meaning and the need to keep them in place and in good condition. Emphasize the increased safety hazards when instructions are not followed.

\_\_\_ Explain to customer the potential crushing hazards of going underneath raised equipment. Instruct customer that service work does not require going underneath unit and never to do so.

\_\_\_ Complete the Warranty Registration located on the Frontier website.

# Operation

Safety is a primary concern in the design and manufacture of our products. Unfortunately, our efforts to provide safe equipment can be wiped out by an operator's single careless act.

In addition to the design and configuration of equipment, hazard control and accident prevention are dependent upon the awareness, concern, judgement, and proper training of personnel involved in the operation, transport, maintenance and storage of equipment.

It has been said "The best safety device is an informed, careful operator." We ask you to be that kind of operator.

The operator is responsible for the safe operation of this equipment. The operator must be properly trained. Operators should be familiar with the equipment, the tractor, and all safety practices before starting operation. Read the safety rules and safety decals on pages 2-6.

Owner should check and tighten all hardware after the first hour of operation. The break in stage of your new land plane can cause minimal loosening of hardware. Please see Bolt Torque Chart (page 13) for proper torque information.

## **WARNING**

- Power unit must be equipped with ROPS or ROPS cab and seat belt. Keep seat belt securely fastened. Falling off power unit can result in death from being run over or crushed. Keep foldable ROPS systems in "locked up" position at all times.
- Never allow children or untrained persons to operate equipment.
- Keep bystanders away from equipment.

- **NEVER GO UNDERNEATH EQUIPMENT.** Never place any part of the body underneath equipment or between moveable parts even when the engine has been turned off. Hydraulic system leak down, hydraulic system failures, mechanical failures, or movement of control levers can cause equipment to drop or rotate unexpectedly and cause severe injury or death.

- Service work does not require going underneath.

- Read Manual for service instructions or have service performed by a qualified dealer.

- Stop tractor and implement immediately upon striking an obstruction. Turn off engine, remove key, inspect, and repair any damage before resuming operation.

- Always wear relatively tight and belted clothing to avoid entanglement in moving parts. Wear sturdy, rough-soled work shoes and protective equipment for eyes, hair, hands, hearing, and head.

### **Owner/Operator Pre-Operation Checklist (Owner's/Operator's Responsibility)**

\_\_\_ Review and follow all safety rules and safety decal instructions on page 2 through page 6.

\_\_\_ Check that equipment is properly and securely attached to tractor.

\_\_\_ Check that all safety decals are installed and in good condition. Replace if damaged.

\_\_\_ Check that all hardware is properly installed and secured.

\_\_\_ Do not allow riders.

\_\_\_ Make sure tractor ROPS or ROPS CAB and seat belt are in good condition. Keep seat belt securely fastened during operation.

## Connecting Land Plane to Tractor

The land plane is compatible with tractors equipped with Category 1 or Category 2, 3-point hitch systems that use side-swing type lower lift arms. The land planes will also fit tractors equipped with a Category 1 and 2 Quick Hitch system.

NOTE: When attaching land plane to any hitch other than a standard Category 1 hitch, bushings must be purchased separately.

Figure 1. Category 1 and 2 Hitch Set-up

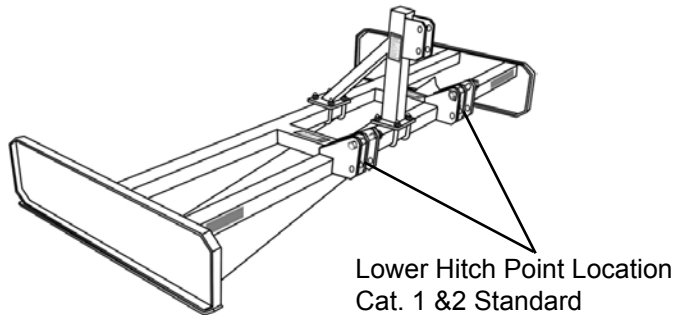

### Category 1 Standard (Figure 1)

1. Attach the tractor's lower lift arms to the land plane through the lower, inner set of holes.
2. Use the hitch pin supplied with your land plane and re-install the lynch pins.
3. Attach the tractor's top link to the land plane's mast using the heavy-duty top link pin and lynch pin supplied with the top link.

Figure 2. Category 1 Quick Hitch Set-up

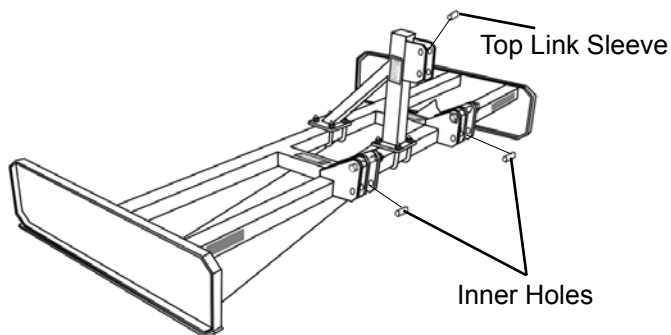

### Category 2 Standard (Figure 1)

1. Use Category 1 Standard instructions except use lower, outer set of holes.

### Category 1 Quick Hitch (Figure 2)

1. Connect the tractor's Quick Hitch to the land plane through the upper, inner set of holes.

2. Slide lower sleeve (sold separately) over the mounting pin supplied with land plane. Re-install lynch pins.
3. Slide upper sleeve over the heavy-duty top link pin supplied with top link. Reinstall retaining pin.

Figure 3. Category 2 Quick Hitch Set-up

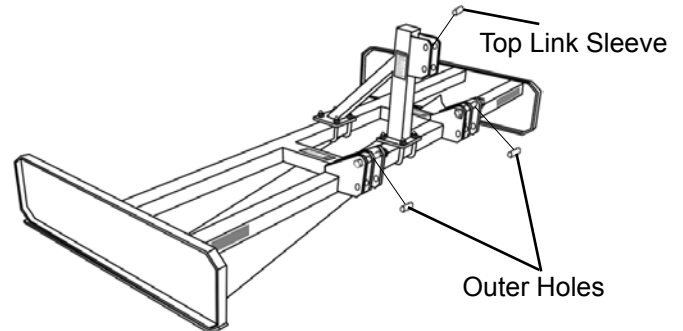

### Category 2 Quick Hitch (Figure 3)

1. Connect the tractor's Quick Hitch to the land plane through the upper, outer set of holes.
2. Slide upper sleeve over the heavy-duty top link pin supplied with top link. Reinstall retaining pin.

## Adjusting Top Link

Adjust the three point top link so that both blades touch the ground at the same time. In most cases this will give the desired results. To adjust the front blade to cut more than the rear, shorten the three point top link. Lengthen the top link to make the rear blade cut more.

## Owner Service

### **WARNING**

- NEVER GO UNDERNEATH EQUIPMENT. Never place any part of the body underneath equipment or between moveable parts even when the engine has been turned off. Hydraulic system leak down, hydraulic system failures, mechanical failures, or movement of control levers can cause equipment to drop or rotate unexpectedly and cause severe injury or death.
- Service work does not require going underneath.

### **WARNING**

- Read Manual for service instructions or have service performed by a qualified dealer.

### **CAUTION**

The information in this section is written for operators who possess basic mechanical skills. If you need help, your dealer has trained service technicians available. For your protection, read and follow the safety information in this manual.

### **WARNING**

- Keep all persons away from operator control area while performing adjustments, service, or maintenance.
- Before dismounting power unit or performing any service or maintenance, follow these steps: disengage power to equipment, lower the 3 point hitch and all raised components to the ground, operate valve levers to release any hydraulic pressure, set parking brake, stop engine, remove key, and unfasten seat belt.
- Always wear relatively tight and belted clothing to avoid entanglement in moving parts. Wear sturdy, rough-soled work shoes and protective equipment for eyes, hair, hands, hearing, and head.

### **CAUTION**

#### **Storage**

When storing your land plane make sure the unit is placed on level ground and clear of any obstructions. Use caution when disconnecting the land plane from the tractor.

# Parts Catalog

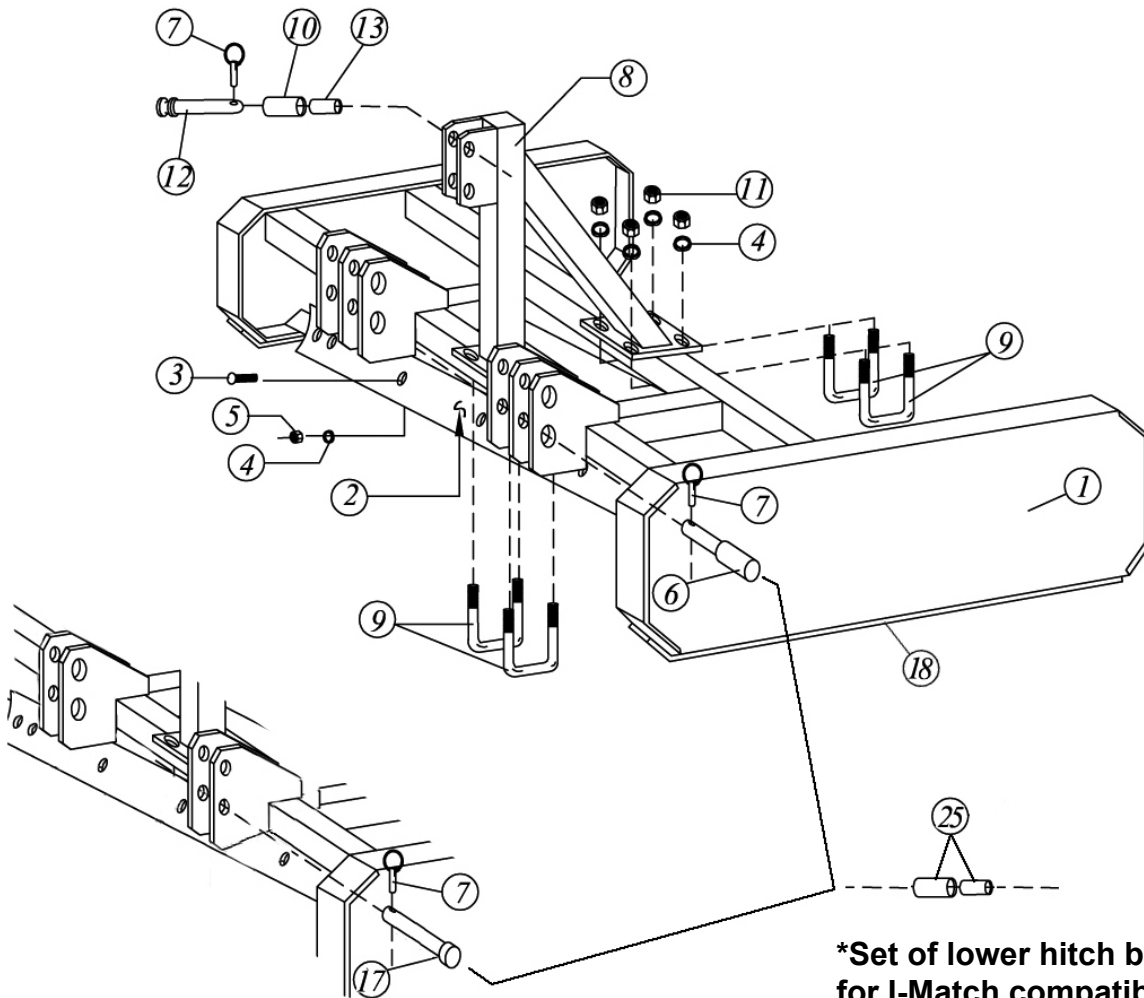

**Cat. 1 Hitch  
LP1160 and LP1172 Only**

**\*Set of lower hitch bushings  
for I-Match compatibility  
sold separately.**

**Parts Catalog(cont'd.)**

<b>Ref.#</b>	<b>Part #</b>	<b>Description</b>	<b>Qty.</b>
1	TL14789	MAIN FRAME WELDMENT 60"	1
	TL14790	MAIN FRAME WELDMENT 72"	1
	TL14791	MAIN FRAME WELDMENT 84"	1
	TL14792	MAIN FRAME WELDMENT 96"	1
2	TL10702	CUTTING EDGE 60"	2
	TL10704	CUTTING EDGE 72"	2
	TL10705	CUTTING EDGE 84"	2
	TL10706	CUTTING EDGE 96"	2
3	TL10699	PLOW BOLT, 5/8" X 1 3/4" GR5	*MS
4	TLT-24	LOCK WASHER, 5/8"	*MS
5	TLT-22	HEX NUT, 5/8"	*MS
6	TL13257	HITCH PIN, CAT 1 AND 2	2
7	TLVP252	LYNCH PIN	3
8	TL15602	MAST WELDMENT	1
9	TL11139	U-BOLT, 5/8" FOR 3" X 3" TUBE	4
10	TL15210	CAT 2 BUSHING, 1 15/16"	1
11	TL15132	LOCK NUT, 5/8	8
12	TL15206	CAT 1 TOP LINK PIN, 3 7/8"	1
13	TL15209	CAT 1 BUSHING, 1 15/16"	1
17	TL10684	HITCH PIN, CAT 1, LP1160 AND LP1172 ONLY	2
18	TL14836	REPLACEABLE SKID SHOES(MUST BE WELDED)	2
19	TL15511	WARNING DECALS (4 DECALS) NOT SHOWN	1
20	TL15199	9" RED REFLECTOR (LP1196 ONLY) NOT SHOWN	2
21	TL15200	9" RED REFLECTOR (LP1196 ONLY) NOT SHOWN	2
22	TL15614	ASSEMBLY AND OPERATING MANUAL NOT SHOWN	1
23	TL15285	FRONTIER DECAL NOT SHOWN	2
24	TL15631	LP1160 MODEL DECAL NOT SHOWN	2
	TL15632	LP1172 MODEL DECAL NOT SHOWN	2
	TL15633	LP1184 MODEL DECAL NOT SHOWN	2
	TL15634	LP1196 MODEL DECAL NOT SHOWN	2
25	TL15638	SET OF LOWER HITCH BUSHINGS*	N/A

## Bolt Size Chart

**NOTE:** Chart shows bolt thread sizes and corresponding head (wrench) sizes for standard SAE and metric bolts.

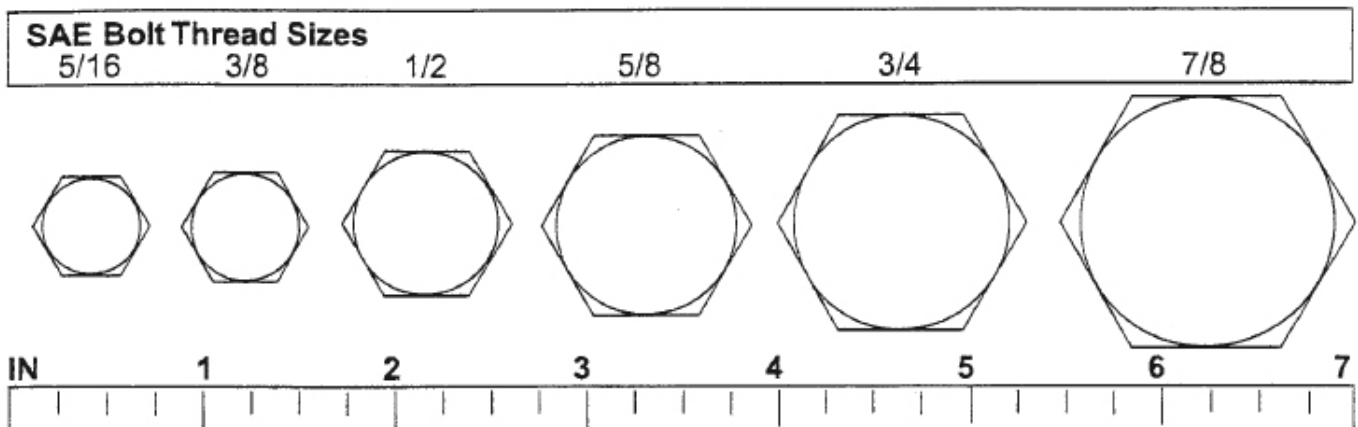

## SAE Torque Chart

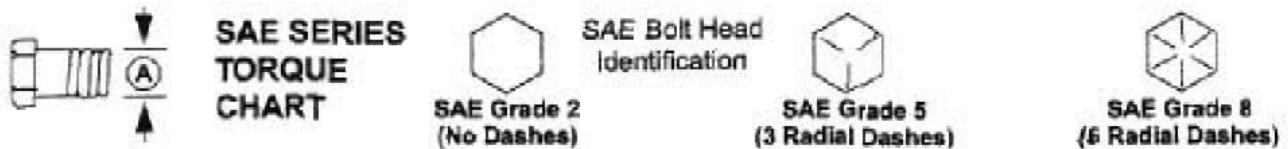

A Diameter (Inches)	Wrench Size	MARKING ON HEAD					
		SAE 2		SAE 5		SAE 8	
		lbs-ft	N-m	lbs-ft	N-m	lbs-ft	N-m
1/4"	7/16"	6	8	10	13	14	18
5/16"	1/2"	12	17	19	26	27	37
3/8"	9/16"	23	31	35	47	49	67
7/16"	5/8"	36	48	55	75	78	106
1/2"	3/4"	55	75	85	115	120	163
9/16"	13/16"	78	106	121	164	171	232
5/8"	15/16"	110	149	170	230	240	325
3/4"	1-1/8"	192	261	297	403	420	569
7/8"	1-5/16"	306	416	474	642	669	907
1"	1-1/2"	467	634	722	979	1020	1383

*13 Bolt Size and Bolt Torque Chart*



## WARRANTY

Please enter information below and save for future reference:

Date Purchase: \_\_\_\_\_ From (Dealer): \_\_\_\_\_

Model Number: \_\_\_\_\_ Serial Number: \_\_\_\_\_

Monroe-Tufline Manufacturing Co., Inc. ("Monroe-Tufline") warrants this product to be free from defect in material and workmanship. Except as otherwise set forth below, the duration of this Warranty shall be for TWELVE (12) MONTHS COMMENCING ON THE DATE OF DELIVERY OF THE PRODUCT TO THE ORIGINAL PURCHASER.

Under no circumstances will this Warranty apply in the event that the product, in the good faith opinion of Monroe-Tufline, has been subjected to improper operation, improper maintenance, misuse, or an accident. This Warranty does not apply in the event that the product has been materially modified or repaired by someone other than Monroe-Tufline, a Monroe-Tufline authorized dealer or distributor, and/or a Monroe-Tufline authorized service center. This Warranty does not cover normal wear or tear, or normal maintenance items. This Warranty also does not cover repairs made with parts other than those obtainable through Monroe-Tufline.

This Warranty is extended solely to the original purchaser of the product. Should the original purchaser sell or otherwise transfer this product to a third party, this Warranty does not transfer to the third party purchaser in any way. There are no third party beneficiaries of this Warranty.

Monroe-Tufline makes no warranty, express or implied, with respect to cutting edges, shanks, tires or other parts or accessories not manufactured by Monroe-Tufline. Warranties for these items, if any, are provided separately by their respective manufacturers.

Monroe-Tufline's obligation under this Warranty is limited to, at Monroe-Tufline's option, the repair or replacement, free of charge, of the product if Monroe-Tufline, in its sole discretion, deems it to be defective or in noncompliance with this Warranty. Such parts shall be provided by the selling dealer to the user during regular working hours. **If requested, the product must be returned to Monroe-Tufline with proof of purchase within thirty (30) days after such defect or noncompliance is discovered or should have been discovered, routed through the dealer and distributor from whom the purchase was made, transportation charges prepaid.** Monroe-Tufline shall complete such repair or replacement within a reasonable time after Monroe-Tufline receives the product. THERE ARE NO OTHER REMEDIES UNDER THIS WARRANTY. THE REMEDY OF REPAIR OR REPLACEMENT IS THE SOLE AND EXCLUSIVE REMEDY UNDER THIS WARRANTY.

THERE ARE NO WARRANTIES WHICH EXTEND BEYOND THE DESCRIPTION ON THE FACE OF THIS WARRANTY. MONROE-TUFLINE MAKES NO OTHER WARRANTY, EXPRESS OR IMPLIED, AND MONROE-TUFLINE SPECIFICALLY DISCLAIMS ANY IMPLIED WARRANTY OF MERCHANTABILITY AND/OR ANY IMPLIED WARRANTY OF FITNESS FOR A PARTICULAR PURPOSE (EXCEPT WHERE PROHIBITED BY LAW).

**Monroe-Tufline shall not be liable for any incident or consequential losses, damages or expenses, arising directly or indirectly from the product, whether such claim is based upon breach of contract, breach of warranty, negligence, strict liability in tort or any other legal theory.** Monroe-Tufline's obligation under this warranty, to the extent allowed by law, is in lieu of all warranties, implied or expressed for a particular purpose and any liability for incidental and consequential damages with respect to the sale or use of the items warranted. Such incidental and consequential damages shall include but not be limited to: transportation charges other than normal freight charges; loss of crops or any other loss of income; rental of substitute equipment, expenses due to loss, damage, detention or delay in the delivery of equipment or parts resulting from acts beyond the control of Monroe-Tufline.

This Warranty is subject to any existing conditions of supply which may directly affect Monroe-Tufline's ability to obtain materials or manufacture replacement parts.

No agent, representative, dealer, distributor, serviceperson, salesperson, or employee of any company, including without limitation, Monroe-Tufline, its authorized dealers, distributors, and service centers, is authorized to alter, modify, or enlarge this Warranty.

**This Warranty is subject to the warranty registration being submitted.** For warranty services, contact your selling dealer.

*Warranty 14*

## WARRANTY FOR PARTS

Monroe-Tufline Manufacturing Co., Inc. ("Monroe-Tufline") warrants its parts to be free from defect in material and workmanship for a period of ninety (90) days from the date of delivery of the part(s) to the original purchaser.

Replacement or repair parts installed in the equipment covered by warranty are warranted for ninety (90) days from date of purchase of such part or to the expiration of the applicable new equipment warranty period, whichever occurs later.

Under no circumstances will this Warranty apply in the event that the product the parts are installed in, in the good faith opinion of Monroe-Tufline, has been subjected to improper operation, improper maintenance, misuse, or an accident. This Warranty does not cover normal wear or tear, or normal maintenance items.

This Warranty is extended solely to the original purchaser of the product. Should the original purchaser sell or otherwise transfer this product to a third party, this Warranty does not transfer to a third party purchaser in any way. There are no third party beneficiaries of this Warranty.

Monroe-Tufline's obligation under this Warranty is limited to, at Monroe-Tufline's option, the repair or replacement, free of charge, of the product if Monroe-Tufline, in its sole discretion, deems it to be defective or in noncompliance with this Warranty. The selling dealer shall provide such parts to the user during regular working hours. **If requested, the product must be returned to Monroe-Tufline with proof of purchase within thirty (30) days after such defect or noncompliance is discovered or should have been discovered, routed through the dealer and distributor from whom the purchase was made, transportation charges prepaid.** Monroe-Tufline shall complete such repair or replacement within a reasonable time after Monroe-Tufline receives the product. THERE ARE NO OTHER REMEDIES UNDER THIS WARRANTY. THE REMEDY OF REPAIR OR REPLACEMENT IS THE SOLE AND EXCLUSIVE REMEDY UNDER THIS WARRANTY.

THERE ARE NO WARRANTIES WHICH EXTEND BEYOND THE DESCRIPTION ON THE FACE OF THIS WARRANTY. MONROE-TUFLINE MAKES NO OTHER WARRANTY, EXPRESS OR IMPLIED, AND MONROE-TUFLINE SPECIFICALLY DISCLAIMS ANY IMPLIED WARRANTY OF MERCHANTABILITY AND/OR ANY IMPLIED WARRANTY OF FITNESS FOR A PARTICULAR PURPOSE (EXCEPT WHERE PROHIBITED BY LAW).

**Monroe-Tufline shall not be liable for any incidental or consequential losses, damages or expenses, arising directly or indirectly from the product, whether such claim is based upon breach of contract, breach of warranty, negligence, strict liability in tort or any other legal theory.** Without limiting the generality of the foregoing, Monroe-Tufline specifically disclaims any damages relating to (i) lost profits, business, revenues or goodwill; (ii) loss of crops; (iii) loss because of delay in harvesting; (iv) any expense or loss incurred for labor, supplies, substitute machinery or rental; or (v) any other type of damage to property or economic loss.

This Warranty is subject to any existing conditions of supply which may directly affect Monroe-Tufline's ability to obtain materials or manufacture replacement parts.

No agent, representative, dealer, distributor, service person, salesperson, or employee of any company, including without limitation, Monroe-Tufline, its authorized dealers, distributors, and service centers, is authorized to alter, modify, or enlarge this Warranty.

For warranty services, contact your selling dealer.

*15 Warranty for Parts*



**PART NO.  
TL15614**

***Tufline***<sup>®</sup>

To see our full line of Agricultural, Landscape and Sportsman implements visit us on the web at  
[monroetufline.com](http://monroetufline.com)

PO Box 7755, Columbus, MS 39705 • Phone (662) 328-8347 • Fax (662) 328-8361

© 2008 Monroe Tufline Manufacturing, Inc. All Rights Reserved