

Tube-Line Techno-Bale **960**

Operator's Manual



TUBE•LINE™
MANUFACTURING LTD.

One- Year Manufacturer's
Warranty
For Normal Use With The Exception Of Tires

If the Equipment does not function properly, or if a piece is defective due to a manufacturer's defect during the first year following purchase, the defect will be repaired free of charge.

If this machine is used for commercial application or for lease/rent, this guarantee will be valid for 90 days following the date of purchase.

Your satisfaction is essential to us. The department of customer service at point of purchase should resolve any problem concerning this equipment. If you have a warranty related problem that has not been rectified to your satisfaction, we suggest that you take the following action:

- ➔ Speak to the manager at the point of purchase. Most problems can be rectified at this level.
- ➔ If you have already consulted the manager and there has not been an acceptable resolution, you may contact the manufacture directly.

Tubeline Manufacturing Inc.

R.R.#4 Elmira, Ontario N3B 2Z3

Telephone : (519) 664-0488

Fax : (519) 664-0492

E-mail : sales@tubeline.ca

On the Web at www.tubeline.ca

To better serve you, please include the following information :

- ➔ Your name, address, and phone number
- ➔ Model number and serial number
- ➔ The date of purchase and the name of your supplier
- ➔ Nature of the problem

After studying your request, you will be advised of the steps to be taken. Note that your situation will be rectified through your supplier, with their equipment and personnel. It is therefore very important that the first attempt to rectify the problem/ question be with the supplier. For future reference, take note immediately of the model number, serial number and date of purchase. The serial number is located at the rear of the left tongue, close to the deck.

Safety

Take Note ! This safety symbol is found throughout this manual to call your attention to instructions involving yourself and others working around the machine

- **Failure to follow these instructions can result in injury or death**



This symbol means

- Attention**
- Become Alert**
- Your safety is involved**

Signal Words are used in this book.

Caution : Indicates a potentially hazardous situation that may result in injury

Warning : Indicates a potentially hazardous situation that could result in serious injury or death

Danger : Indicates a hazardous situation that needs to be avoided. It is you, the operator, that needs to be aware of these dangers.

Safety and Security



The following precautions are suggested for the purpose of accident prevention. The best operator is a prudent operator. Most accidents can be avoided with certain care. Please read all information carefully before operating your Techno-Bale. Only a trained and responsible operator should operate this equipment.

Training

1. Read the Manual
2. Learn the controls of the Technobale
3. Identify the moving parts
4. Know how to stop the machine during any function

Precautions

1. Know the range of all the moving parts
2. Never let anyone stand near or touch any moving parts
3. Never work **on or under** the machine while the bed is raised. (unloading position)
4. The Technobale must be used only by experienced operators.
5. The loading arm is held in vertical position with a security valve when the Technobale is not connected to the tractor. In addition, the security valve must be closed for road transportation.
6. The operator must wear properly fitting clothing and prohibit anyone wearing loose fitting clothing to be near any moving parts.

Maintenance

1. Follow the recommendations in this manual
2. During inspections assure that the moving parts are stopped
3. Secure the moving parts to ensure that the service person will not be trapped if a hydraulic line breaks or comes loose



Safety-- It's in your Interest



Safety Guidelines

Safety of the operator is our main concern, however we do hear of some accidents that could have been avoided if some precautions had been taken. To avoid personal injury study the following precautions and insist those working with you or for you, follow them.

In most cases the pictures will have the shielding in place, in some they may be removed, only to show a view behind the shield.

Keep all the shields, safety doors in place. If they become faulty and fail to work replace them. They are for your safety, do not operate the equipment with them removed.

Replace any decals that may be missing or that are not readable. Location of the decals is indicated in this manual.

Do not operate this machine while under the influence of drugs or alcohol.

Review the safety instructions with all users annually.

This equipment should not be operated by children, or with those unfamiliar with the operation of the machine. **Do not allow persons to operate this machine until they have read this manual and/or were instructed by a qualified person.**

Do not paint over, remove or deface any safety signs or warning decals on your equipment. **Observe all safety signs and practice the instructions on them.**



Lighting and Marking

This machine is equipped with lights and reflectors as required by the most stringent government and ASAE specifications. They should work with the tractor 7 pin connector.



Remember

Your best assurance against accidents or damage to the machine is to know how it operates. If you do not understand a portion of the manual or a function of the Technobale please contact your dealer or an experienced operator.



Before Operation

- Carefully study and understand the manual or be trained by an experienced operator.
- Do not wear loose clothing which may get caught in moving parts.
- Visually inspect the machine to make sure no parts are loose or missing
- Be sure that no tools are left on the machine
- Do not hurry the learning process. Be familiar with one part before trying the next part
- Practice by running the machine through its paces without bales

Safety Decal Location

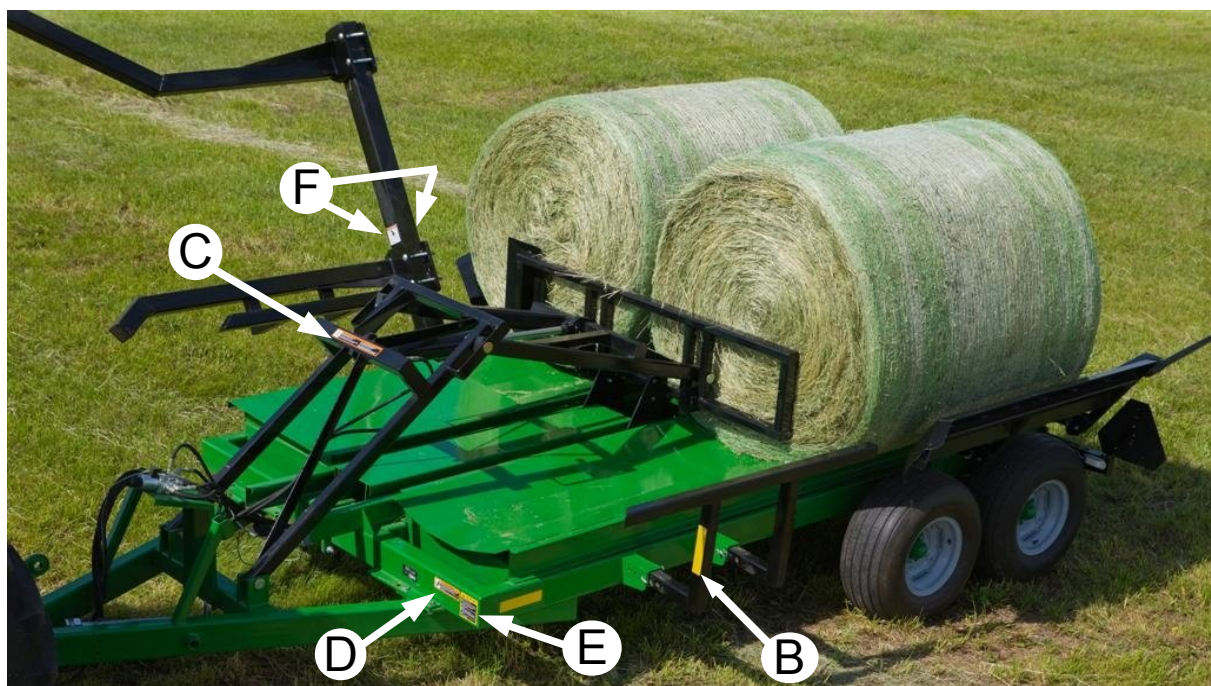
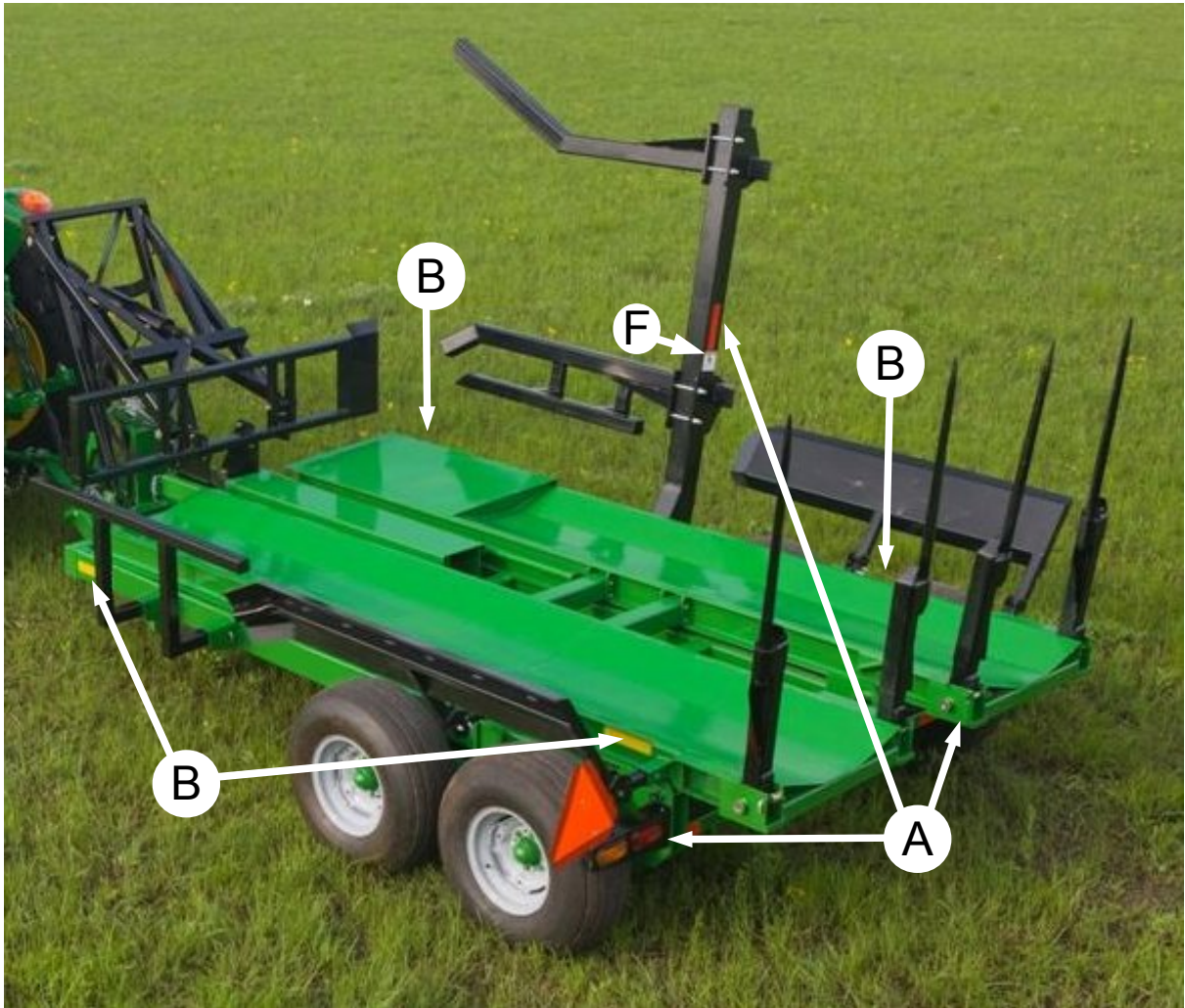

Safety Decals



ITEM - A
PART# - DERED

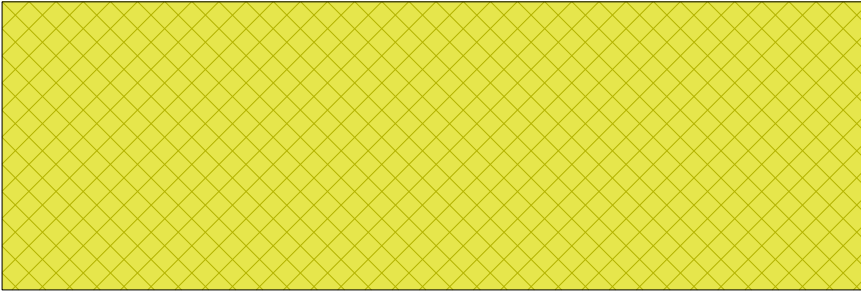

ITEM - B
PART# - DEAMBER

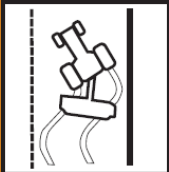

⚠ WARNING

Do not exceed this implement's maximum transport speed of 32km/h (20mph)

Exceeding this speed may result in loss of control during transport or braking and serious injury or death.

Transport only with a properly ballasted tractor and a properly attached safety tow chain. Do not transport with a motor vehicle. Reduce speed and use additional caution when on inclines, towing under adverse surface conditions, and turning.

#DE23942

ITEM - C , PART# - DE23942



⚠ WARNING

High-Pressure hydraulic oil leaks can penetrate skin resulting in serious injury, gangrene, or death.

- Check for leaks with cardboard; never use hand.
- Before loosening fittings: lower load, release pressure, and be sure oil is cool.
- Consult a physician immediately if skin penetration occurs.

ITEM - D , PART# - DE23847

Safety Decals



ITEM - E
PART# - DE23839



ITEM - F
PART# - DE23978

1. Connection

A minimum ballasted tractor weight of 13,000 lbs must be achieved to tow a loaded Technobale on the road.

1. Connect the Technobale to the tractor drawbar
2. Connect the safety chain to the tractor
3. Remove the jack from the vertical position and store it in the horizontal position at the front of the bed (in the space provided)
4. Connect the 4 Quick Couplers to the tractor hydraulic remotes, connect the selector valve to a 12 volt source
5. Open the security valve of the loading arm (ball valve)
6. Test the loading arm, lower and raise to ensure it is hooked up correctly.
7. Leave in the raised position for transportation with the security valve closed.



2. Setup

Numerous adjustments can be made to meet your specific needs.



Deck Extensions

The **Extensions** are attached to the rear of the Technobale. They permit the transportation of one or two extra bales and are used for unloading in-line.



The Guide Rails

The guide rails are adjustable according to the bale diameter



The Loading Arm

The distance between the forks of the loading arm is adjustable according to the diameter of the bales.

Suggested Width Between the Forks

4 x 4 = 42" \diamond 4 x 5 = 45" \diamond 4 x 6 = 48"- 50 " app.

3. Controls

Loading

Open the security valve (ball valve) allowing the loading arm to be raised and lowered with the tractor hydraulics

Push Bar

The other set of hydraulics are used to extend and retract the bale pusher

Unloading

Activate the electric selector valve to change the function of the bale pusher to raise the deck. The deck cylinder has a latch to lock the deck onto the frame, make sure that the cylinder is fully retracted after the deck has been lowered.

4. Loading

The Technobale 960 picks up and moves 9 – 4' wide round bales.

Loading may be done on the go.

One bale may be transported on the loading arm, leaning up against the last bale loaded.

It is possible to pick up a bale even if it is not parallel to the fork. You can rotate its position by using the interior of the outside fork. (see illustration below)

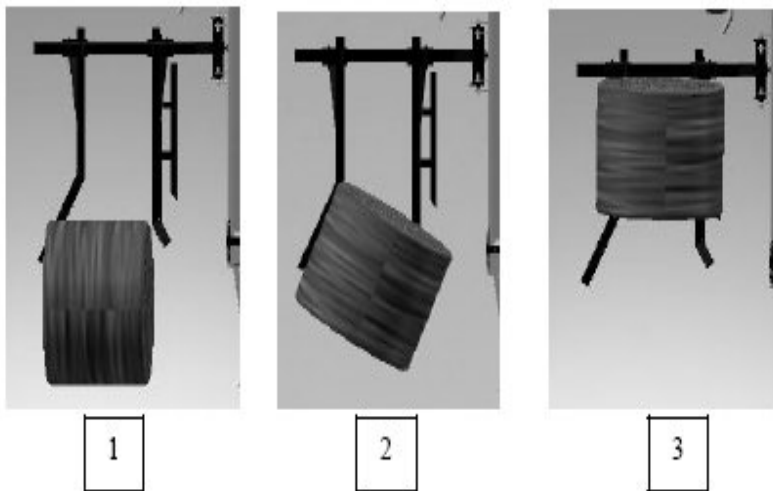

This operation must be executed while moving. After a few tries, you will be able to pick bales up from any position.

5. Overall Process

- Steer towards the bale
- Lower the loading arm completely level to the **ground**
- Line up the point of the exterior fork with the far side of the bale
- Drive into the bale without stopping, and pivot parallel to the loading arm
- Raise the loading arm
- Activate the bale pusher (while driving)
- Continue to the next bale (while lowering the loading arm)
- Load up to 8 bales on the Technobale 960 and raise one additional bale for transport on the loading arm
- To unload remove the bale from the loading arm (by lowering the bale to the ground and backing up), switch the electric diverter valve and activate the same valve as the bale pusher control, this will now activate the deck cylinder.
- Raise the bed to 45° and drive forward to unload



6. Unloading and Storing

Ideal for horizontal storage or staging bales to be wrapped.

If you are transporting a bale on the fork, put down the bale and backup to disengage the bale from the loading arm before unloading the main deck.

To unload, activate the deck cylinder and raise the bed until the bales slide freely. If the incline is too steep, the bales may tumble out. Then move forward until the bales are disengaged from the deck, before lowering the bed.

7. On-Road Transportation

If you must travel a certain distance with an empty Technobale 960 it is recommended to :

- Secure the loading arm in the raised position
- Close the ball valve to hold the loading arm in the vertical position.
- Lock bale extensions in upright position with lock pins
- Attach safety chain

OBSERVE MAXIMUM TRANSPORT SPEED

The maximum transport speed for this implement is 32 km/h (20 mph).

Some tractors are capable of operating at speeds that exceed the maximum transport speed of this implement. Regardless of the maximum speed capability of the tractor being used to tow this implement, do not exceed the implement's maximum transport speed. Exceeding the implements maximum transport speed can result in:

- Loss of control of the tractor/implement combination
- Reduced or no ability to stop during braking
- Implement tire failure
- Damage to the implement structure or its components

Use additional caution and reduce speed when towing under adverse surface conditions, when turning, and when on inclines. Do not attempt transport if the fully loaded implement weighs more than 1.5 times the weight of the tractor.

8. Storing your Technobale 960

- Remove the hydraulic hoses from the tractor and hang them over the hook on the bale pusher arm.
- Remove the selector valve control wire off the tractor and store it on the Technobale 960.
- Close the ball valve to hold the loading arm in the vertical position.
- Reposition the jack in front of the Technobale 960 to keep it level, and to facilitate the next hook-up.
- Lock bale extensions in upright position with lock pins

9. Lubrication

Lubrication intervals will vary depending on grease points, as some joints will be doing more work.

You will find this symbol on the Techno-Bale. Close to the grease points



A – Loading arm cylinder support



Daily

B – Loading arm Support “Pins” (2 sides)



Bi-annually

C – Deck support “Pins”

Situated on each side at the rear of the Techno-Bale (4)



Bi-annually

D – Bale Pusher Arm Cylinder Bracket



Monthly

E – Axle “walking beams” (2 sides)



Bi-annually (generously)

F – Bale Pusher Wheel Axles (4 Wheels)



Monthly

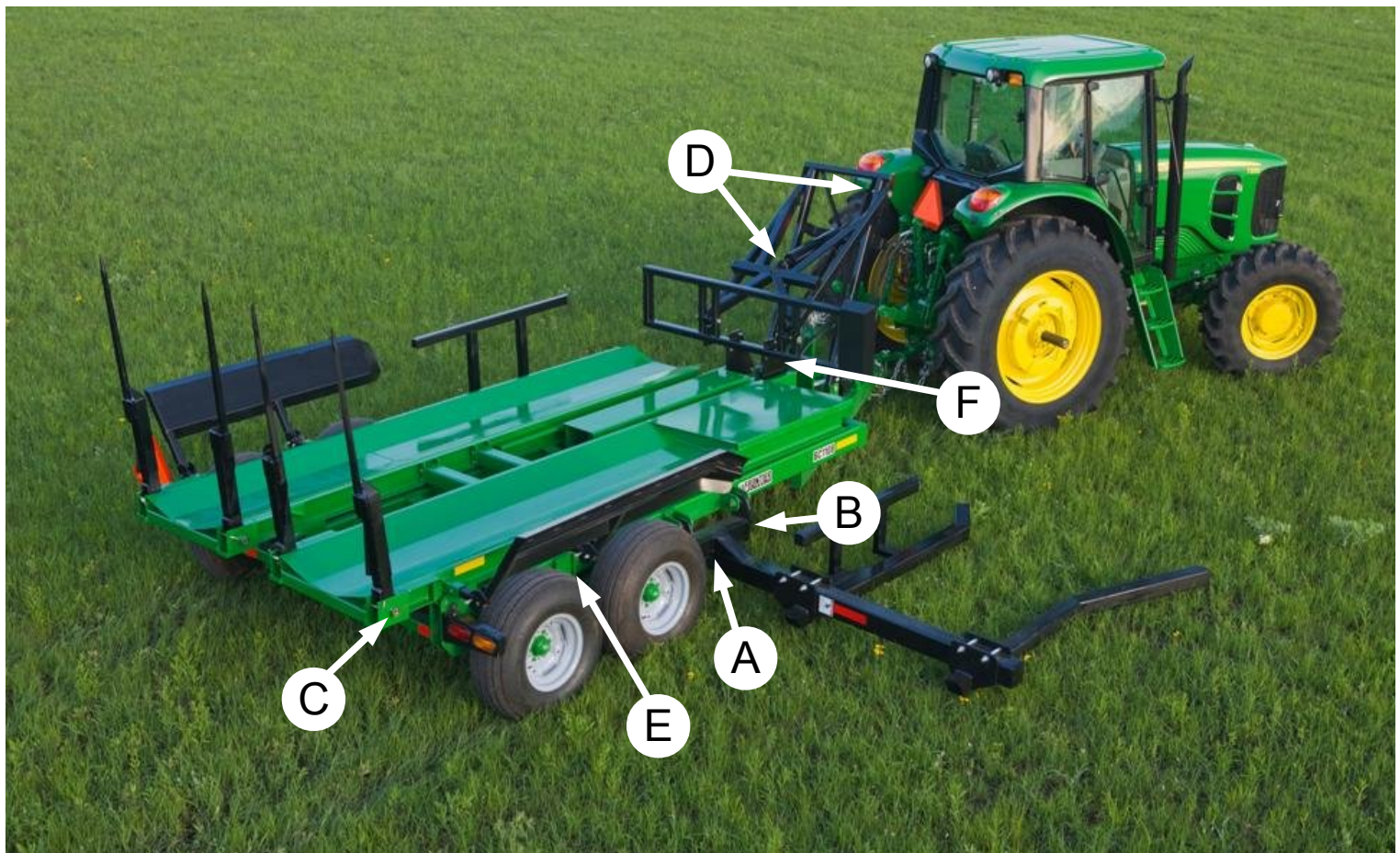

10. Troubleshooting

If the machine is not functioning properly verify that:

- The tractor hydraulic system is working
- The hydraulic hoses are properly connected
- The loading security valve is not closed (must be opened)
- Hydraulic connections are not reversed

If the twine/netwrap is snagging on the rear railing:

- The side arm railing may be adjusted to accommodate bales from 48” to 60” in diameter.
- Verify that you have the proper loading arm width setting.

If you have no power on the selector valve:

- Check the fuse and /or the ground, also check for broken wire.

Specifications Technobale 960

Length	25'
Width	10.4'
Weight	4735lbs
Loading Arm Cylinder	3” Bore / 18” Stroke
Ram Cylinder	3” Bore / 18” Stroke
Deck Cylinders	4” Bore / 18” Stroke
Loading Arm	5” x 5” tube
Loading Fork	4” x 4”
Selector Valve (double)	12volt
Tire	(4) Tires 12.5-L-15 farm implement 8 Ply

Main Frame

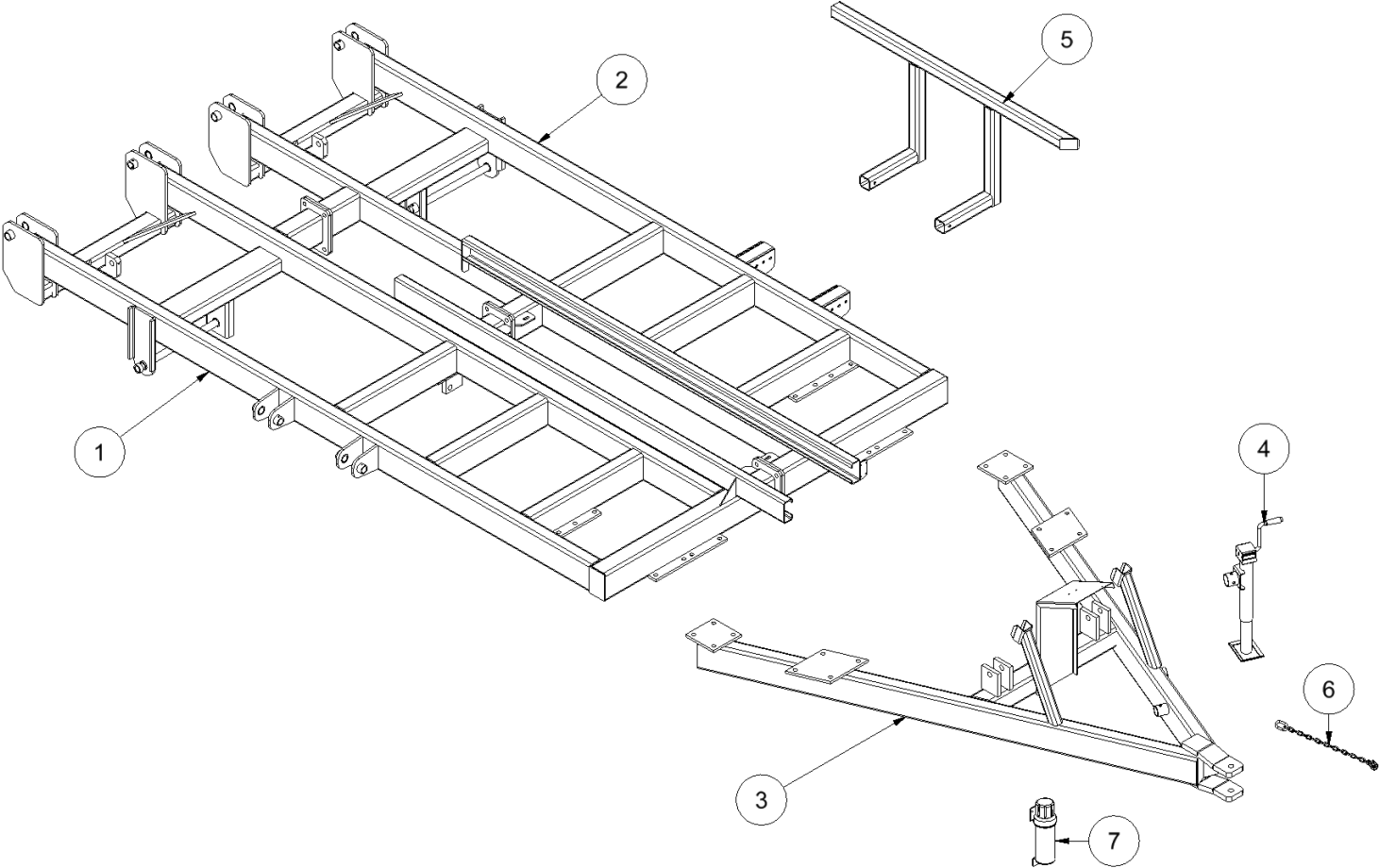

Main Frame

Item	Qty	Part Number	Description
1	1	TB960-100-302	Right Main Frame
2	1	TB960-100-301	Left Main Frame
3	1	TB900-100-102	Hitch
4	1	25719	Jack
5	1	TB900-100-117	Bale Bumper
6	1	25262	Safety Chain
7	1	TL5X2-201-111	Operator Manual

Deck Assembly

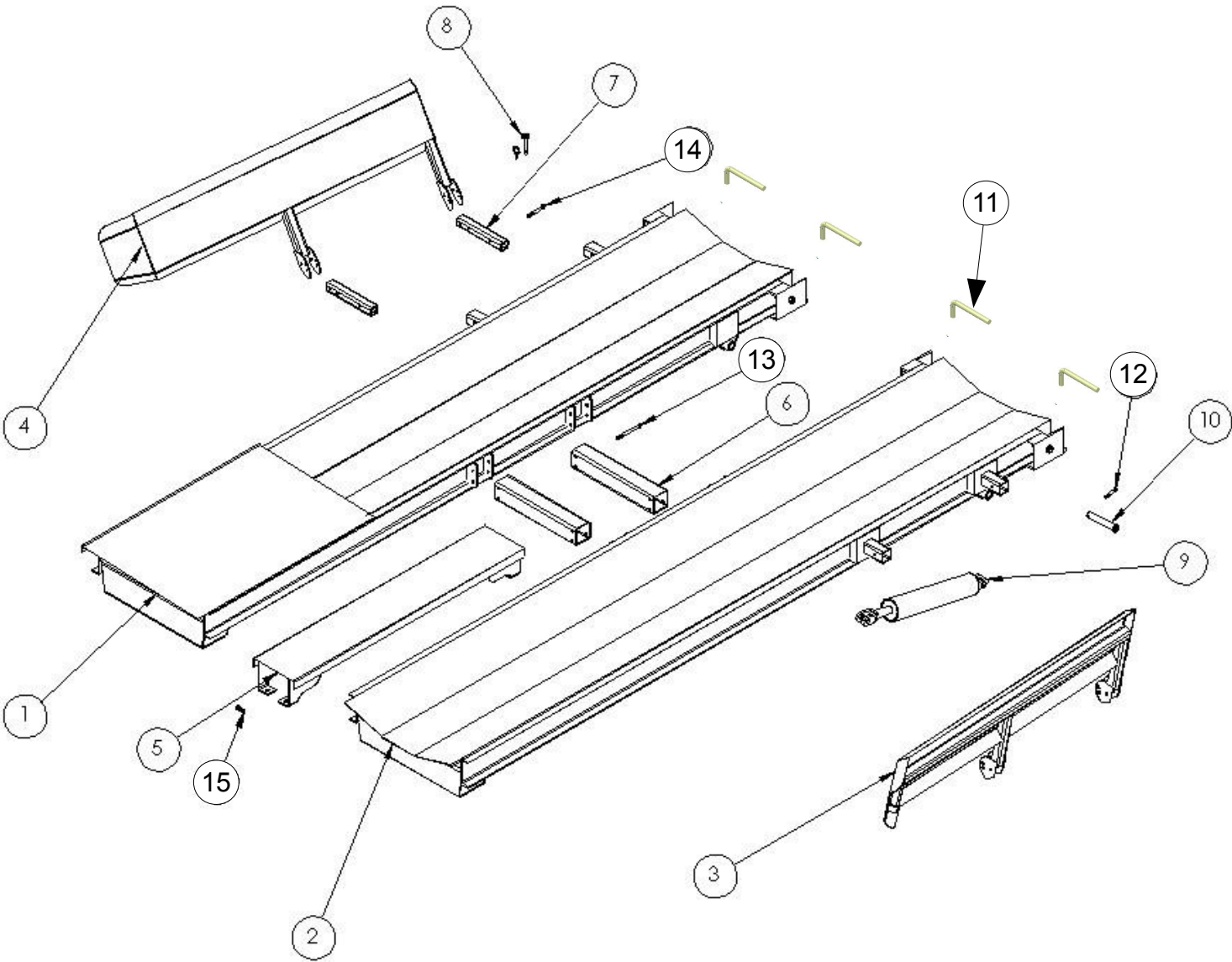

Deck Assembly

Item	Qty	Part Number	Description
1	1	TB960-100-308	Right Deck
2	1	TB960-100-307	Left Deck
3	1	TB960-100-303	Left Bale Guide
4	1	TB960-100-304	Right Bale Guide
5	1	TB960-100-112	Cross Over Deck
6	2	TB960-100-113	Center Deck Tie Tube
7	4	TB960-100-114	Bale Guide Tube
8	4	TB960-100-115	Bale Guide Adjuster Pin w/ Linch Pin
9	2	TB900-100-105	Deck Cylinder
10	4	TB900-100-121	Deck Pivot Pin (short)
11	4	21021	Lock Pin
12	4	Obtain Locally	3/8-16 x 2 ½ Bolt w/ Lock Nut
13	8	Obtain Locally	1/2-13 x 5 ½ Bolt w/ Lock Nut
14	8	Obtain Locally	1/2-13 x 3 ½ Bolt w/ Lock Nut
15	4	Obtain Locally	1/2-13 x 1 ½ Bolt w/ Lock Nut

Ram Assembly

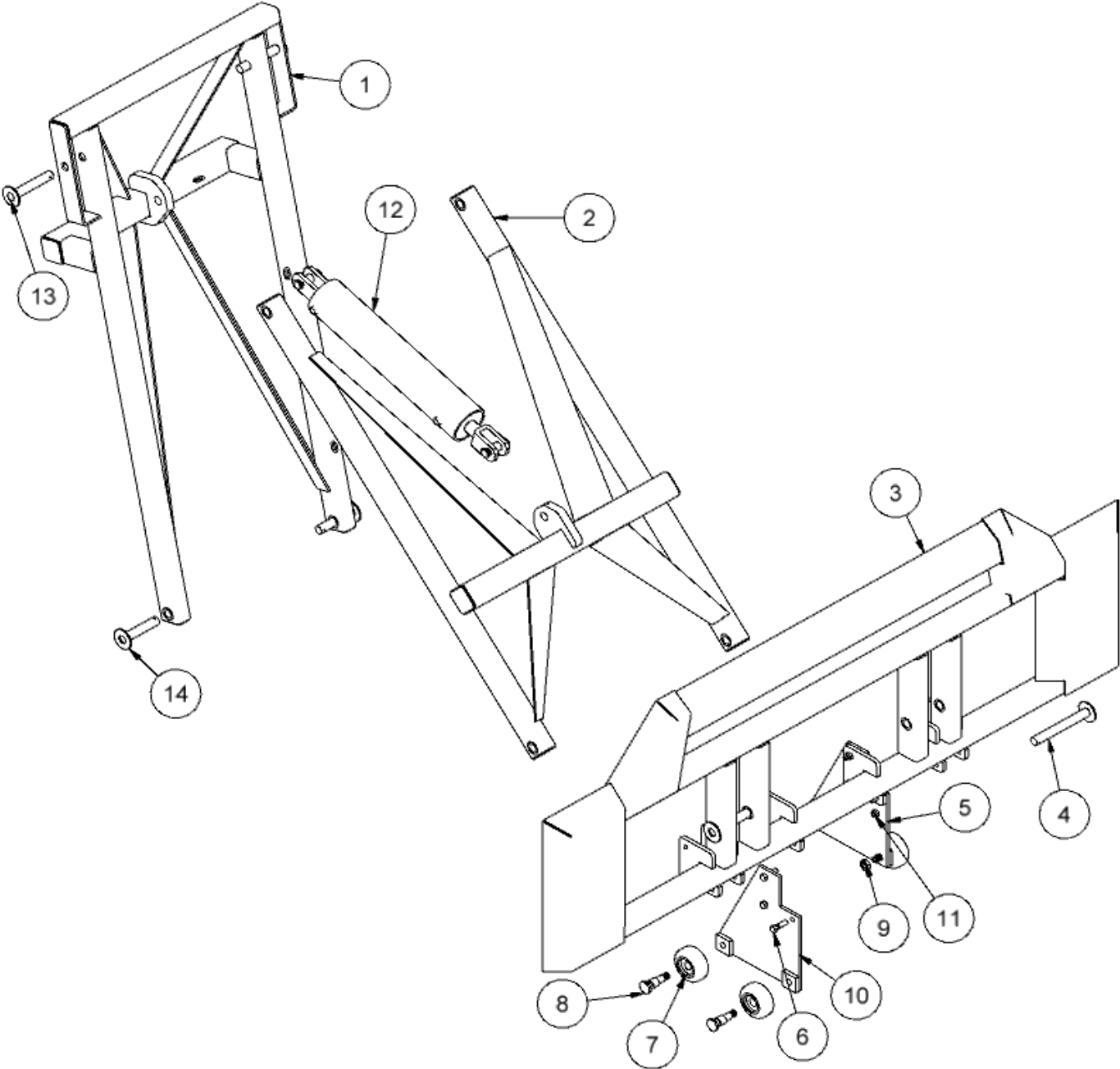

Ram Assembly

Item	Qty	Part Number	Description
1	1	TB960-100-120	Front Scissor Arm
2	1	TB960-100-121	Rear Scissor Arm
3	1	TB960-100-122	Ram
4	2	TB960-100-125	Scissor/ Ram Pin
5	1	TB960-100-305	Left Ram Wheel Mount
6	6	Obtain Locally	HB 1/2-12 x 1 Hex Bolt
7	4	TB960-100-126	Ram Wheel
8	4	TB960-100-127	Ram Wheel Axle
9	4	Obtain Locally	3/4-16 UNF Jam Nut
10	1	TB960-100-306	Right Ram Wheel Mount
11	6	Obtain Locally	LN 1/2-12 Lock Nut
12	1	TB900-100-105	Ram Cylinder
13	2	TB900-100-113	Top Scissor Pin
14	2	TB960-100-124	Frame/Scissor Pin

Bale Arm Assembly

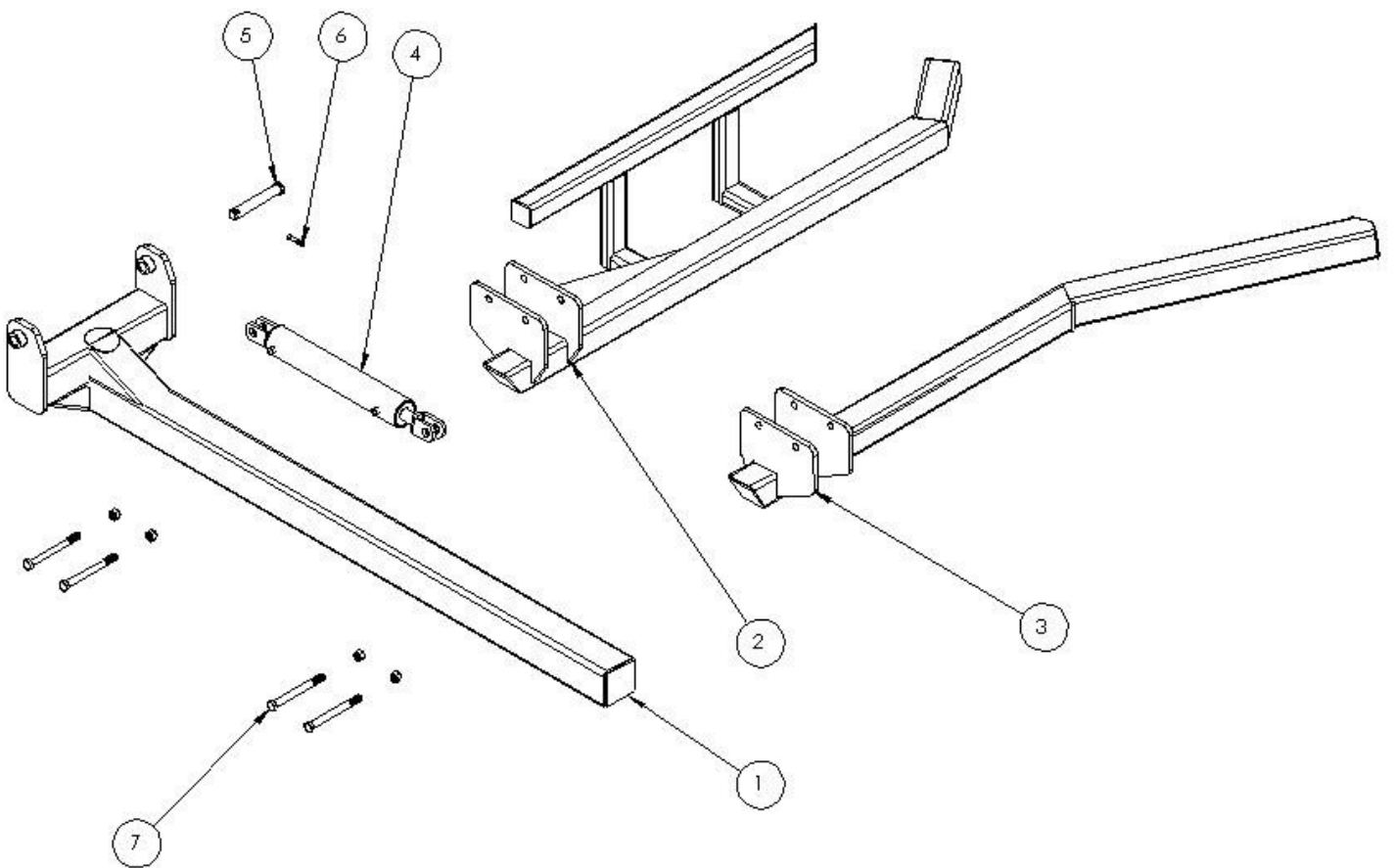

Bale Arm Assembly

Item	Qty	Part Number	Description
1	1	TB900-100-123	Bale Arm
2	1	TB900-100-124	Inside Bale Finger
3	1	TB900-100-125	Outside Bale Finger
4	1	TB900-100-120	Arm Cylinder
5	2	TB900-100-122	Arm Pivot Pin (long)
6	2	Obtain Locally	3/8-16 x 2 Bolt w/ Lock Nut
7	7	Obtain Locally	3/4-10 x 8 Bolt w/ Lock Nut

Axle Assembly

TubeLine Techno-Bale 960

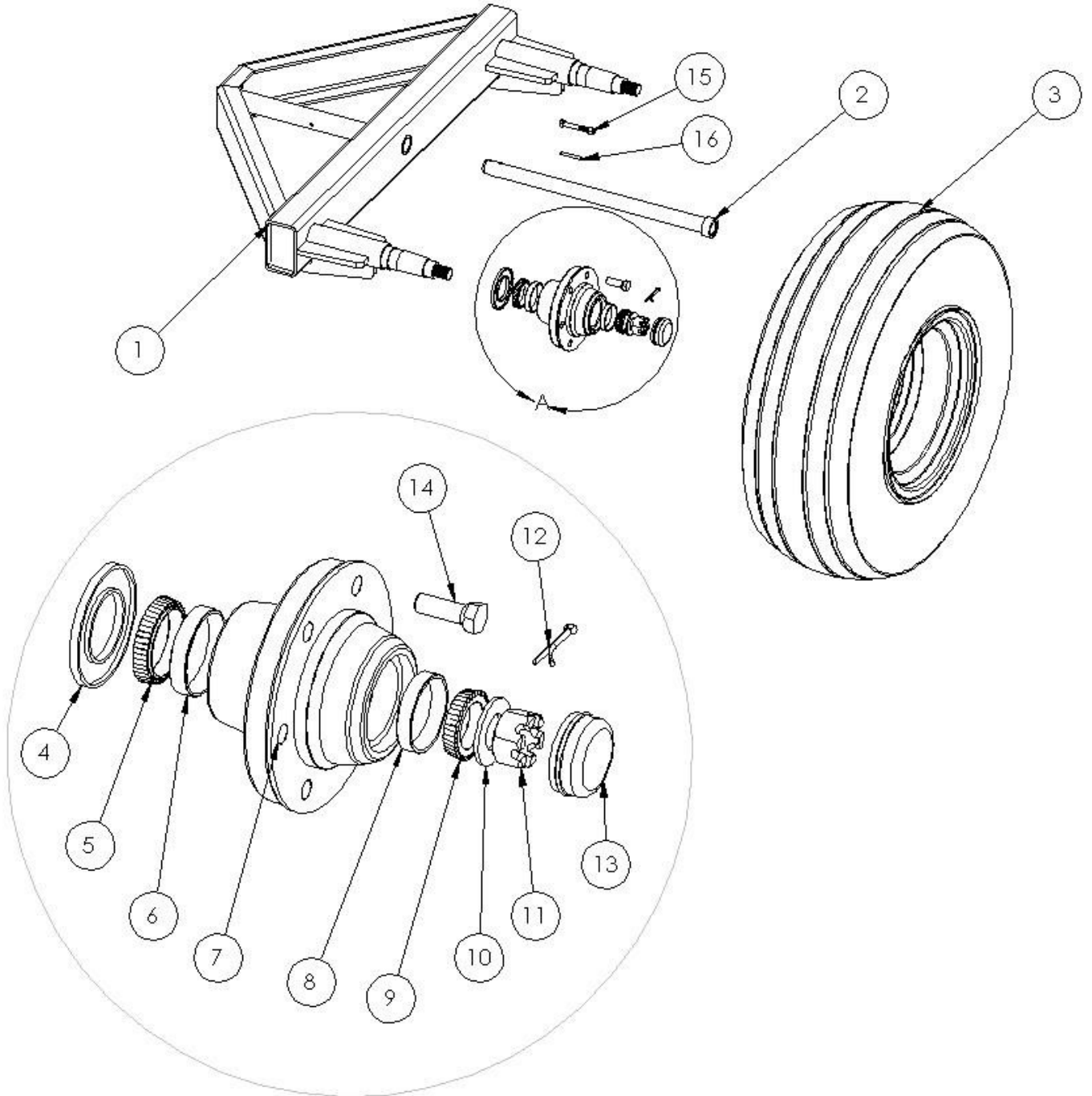

18

Axle Assembly

Item	Qty	Part Number	Description
1	2	TB960-100-130	Axle
2	2	TB900-100-116	Walking Beam Pin
3	4	TB960-100-131	12.5L-15 Tire & Rim
4	4	TB960-100-132	Inner Seal
5	4	TB960-100-133	Inner Bearing
6	4	TB960-100-134	Inner Bearing Race
7	4	TB960-100-135	Hub
8	4	TB960-100-136	Outer Bearing Race
9	4	TB960-100-137	Outer Bearing
10	4	TB960-100-138	Washer
11	4	TB960-100-139	Wheel Nut
12	4	TB960-100-140	Cotter Pin
13	4	TB960-100-141	Dust Cap
14	24	TB960-100-142	Wheel Bolt
15	2	Obtain Locally	3/8-16 x 2 ½ Bolt w/ Lock Nut
16	2	Obtain Locally	¼ x 2 Spring Pin

Rear Table Extension

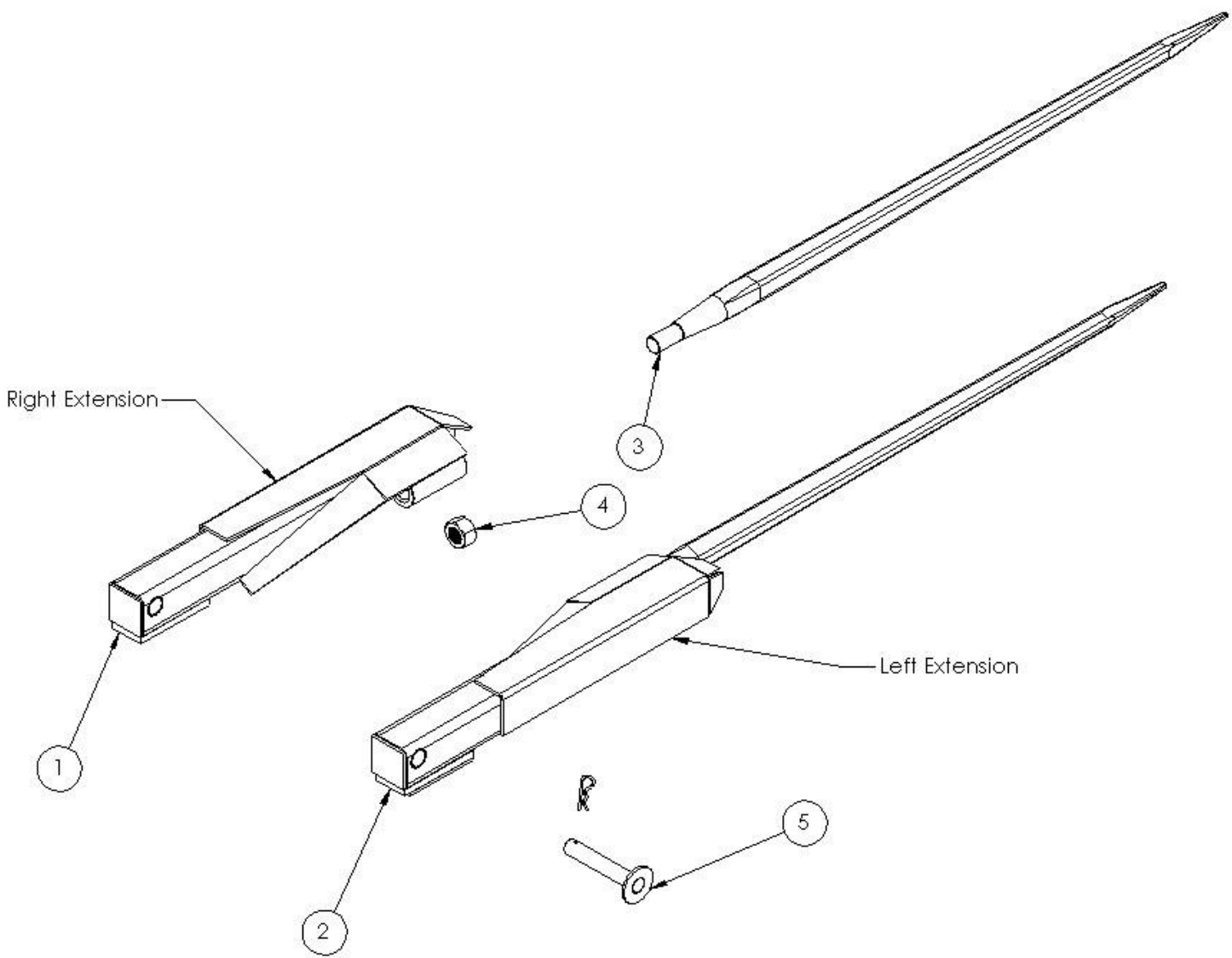

Rear Table Extension

Item	Qty	Part Number	Description
	2	TB900-100-111	Right Extension w/ Spear
	2	TB900-100-110	Left Extension w/ Spear
1	2	TB900-100-140	Right Extension
2	2	TB900-100-141	Left Extension
3	4	TB900-100-133	Conus 2 Spear
4	4	TB900-100-134	Conus 2 Nut
5	4	TB900-100-113	Extension Arm Pivot Pin

Running Lights

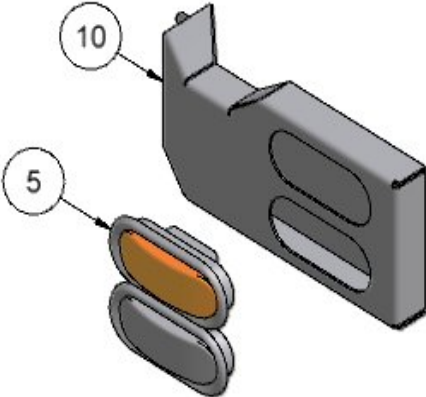
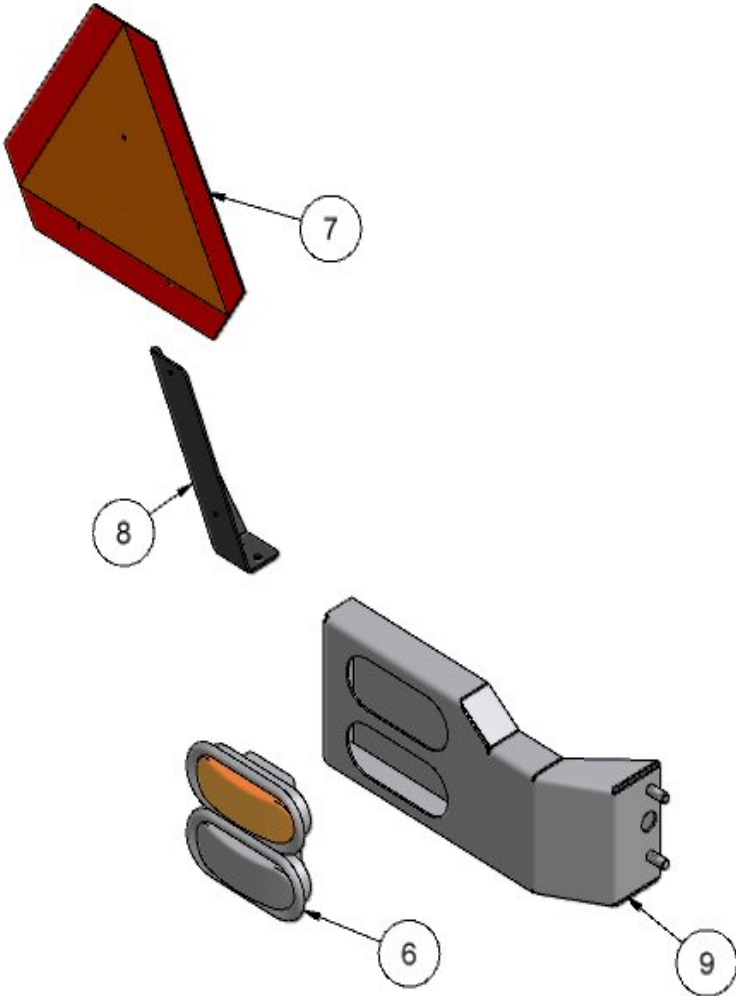

Running Lights

Item	Qty	Part #	Description
1	1	TL550-200-117	7-Pin Plug
2	1	TL550-200-118	Junction Box
3	1	TL550-200-119	Strain Relief (for 7-pin plug)
4	1	TL550-200-120	7-Wire Conductor Wire
5	2	TL550-200-121	Red Light
6	2	TL550-200-122	Amber Light
7	1	DESMV	SMV Sign
8	1	24763	SMV Mount
9	1	25412	Left Light Bracket
10	1	25417	Right Light Bracket
11	1	TL109-110-327	Running Light Wiring Harness

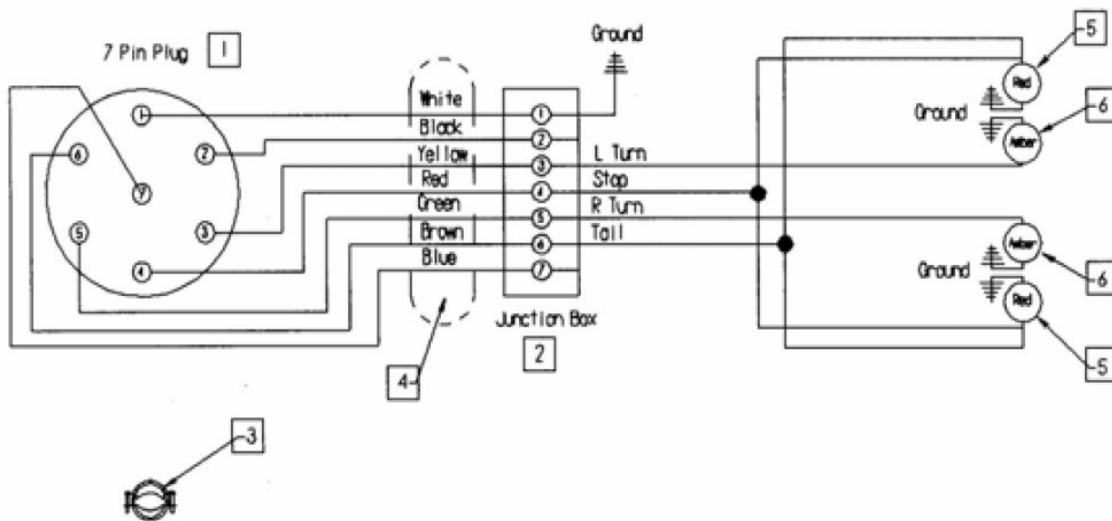

Wiring Harness

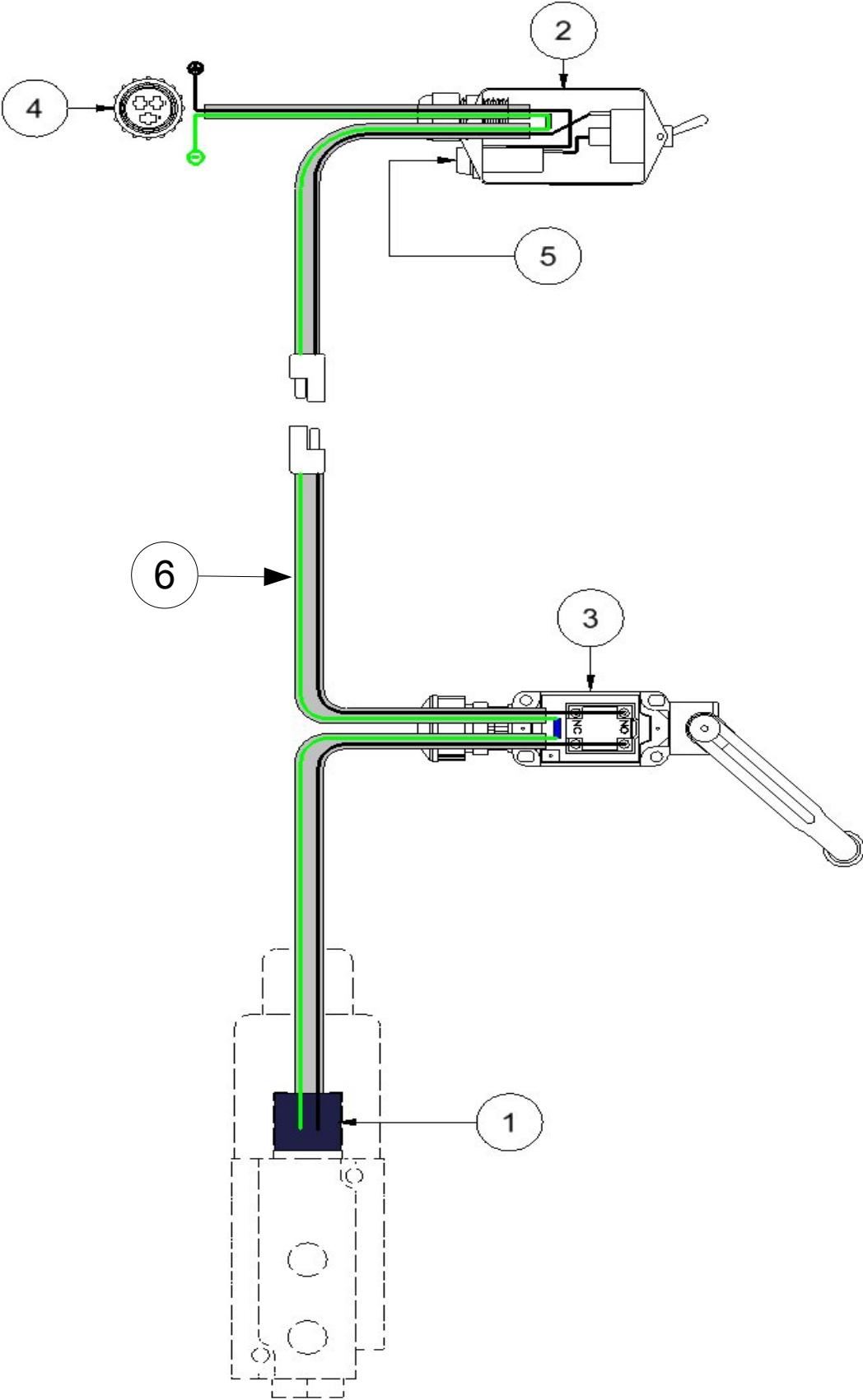

Wiring Harness

Item	Qty	Part #	Description
1	1	TB960-100-153	Valve Connection Box
2	1	TB960-100-152	Switch Box
3	1	TB960-100-150	Limit Switch
4	1	TL109-110-307	Power Plug
5	1	Obtain Locally	15 amp Fuse
6	1	TB960-100-151	Wiring Harness



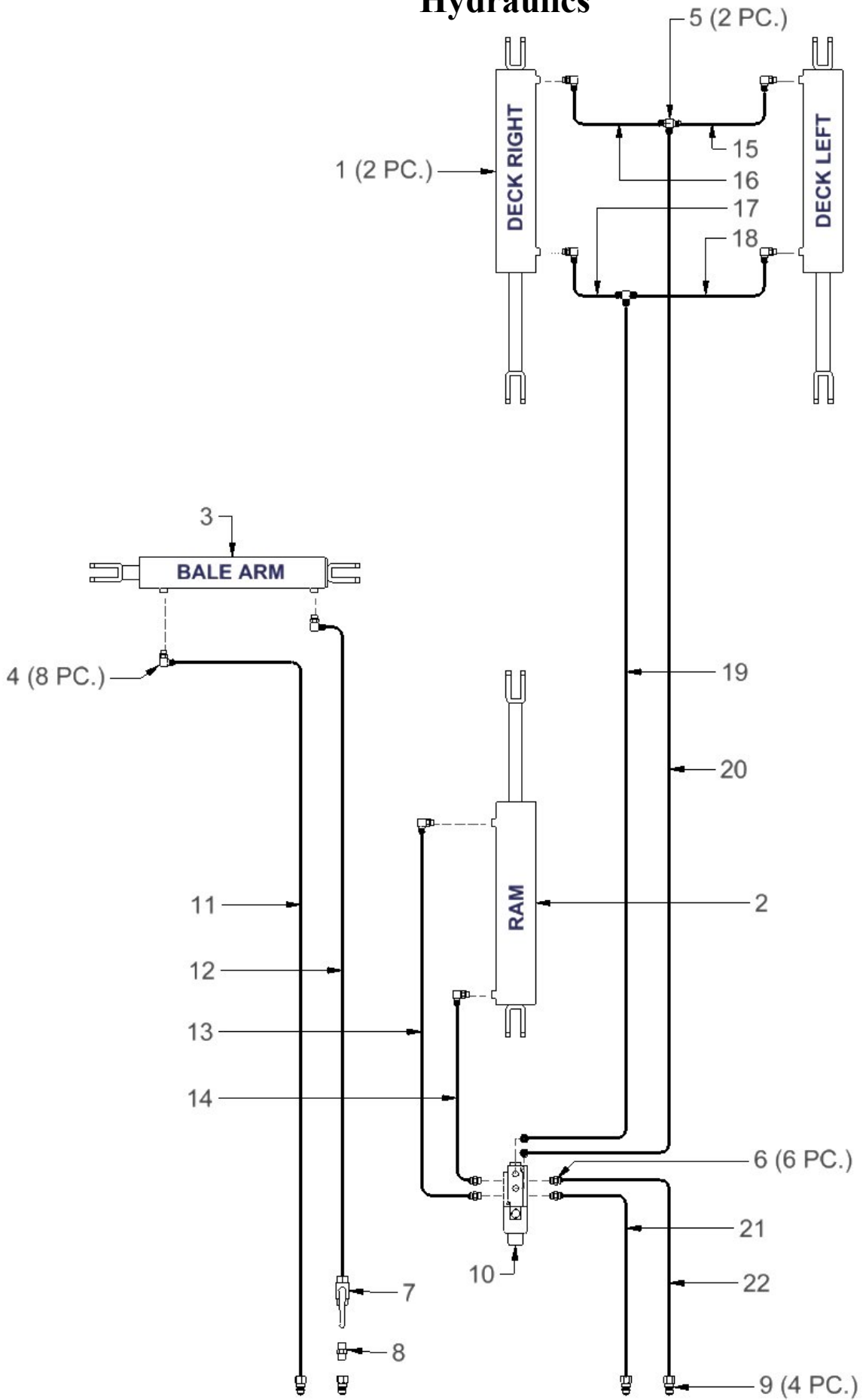







Hydraulics



Hydraulics

Item	Qty	Part #	Description
1	2	TB900100105	Deck Cylinder
2	1	TB900100105	Bale Pusher Cylinder
3	1	TB900100120	Loader Arm Cylinder
4	6	TB109110308	Hydraulic Fitting
5	2	TB109110310	Hydraulic Fitting
6	6	TB109110309	Hydraulic Fitting
7	1	TB960100178	Ball Valve
8	1	TB109110311	Hydraulic Fitting
9	4	TB109110312	Hydraulic Fitting
10	1	TB109110313	Valve
11	1	TB109110314	Hydraulic Hose
12	1	TB109110315	Hydraulic Hose
13	1	TB109110316	Hydraulic Hose
14	1	TB109110317	Hydraulic Hose
15	1	TB109110321	Hydraulic Hose
16	1	TB109110322	Hydraulic Hose
17	1	TB109110323	Hydraulic Hose
18	1	TB109110324	Hydraulic Hose
19	1	TB109110325	Hydraulic Hose
20	1	TB109110326	Hydraulic Hose
21	1	TB109110320	Hydraulic Hose
22	1	TB109110320	Hydraulic Hose

UNIFIED INCH BOLT AND CAP SCREW TORQUE VALUES

SAE Grade and Head Markings	NO MARK	1 or 2 ^b 	5 	5.1 	5.2 	8 	8.2 
	NO MARK	2 	5  		8  		

Size	Grade 1				Grade 2 ^b				Grade 5, 5.1, or 5.2				Grade 8 or 8.2			
	Lubricated ^a		Dry ^a		Lubricated ^a		Dry ^a		Lubricated ^a		Dry ^a		Lubricated ^a		Dry ^a	
	N·m	lb-ft	N·m	lb-ft	N·m	lb-ft	N·m	lb-ft	N·m	lb-ft	N·m	lb-ft	N·m	lb-ft	N·m	lb-ft
1/4	3.7	2.8	4.7	3.5	6	4.5	7.5	5.5	9.5	7	12	9	13.5	10	17	12.5
5/16	7.7	5.5	10	7	12	9	15	11	20	15	25	18	28	21	35	26
3/8	14	10	17	13	22	16	27	20	35	26	44	33	50	36	63	46
7/16	22	16	28	20	35	26	44	32	55	41	70	52	80	58	100	75
1/2	33	25	42	31	53	39	67	50	85	63	110	80	120	90	150	115
9/16	48	36	60	45	75	56	95	70	125	90	155	115	175	130	225	160
5/8	67	50	85	62	105	78	135	100	170	125	215	160	240	175	300	225
3/4	120	87	150	110	190	140	240	175	300	225	375	280	425	310	550	400
7/8	190	140	240	175	190	140	240	175	490	360	625	450	700	500	875	650
1	290	210	360	270	290	210	360	270	725	540	925	675	1050	750	1300	975
1-1/8	400	300	510	375	400	300	510	375	900	675	1150	850	1450	1075	1850	1350
1-1/4	570	425	725	530	570	425	725	530	1300	950	1650	1200	2050	1500	2600	1950
1-3/8	750	550	950	700	750	550	950	700	1700	1250	2150	1550	2700	2000	3400	2550
1-1/2	1000	725	1250	925	990	725	1250	930	2250	1650	2850	2100	3600	2650	4550	3350

DO NOT use these values if a different torque value or tightening procedure is given for a specific application. Torque values listed are for general use only. Check tightness of fasteners periodically.

Shear bolts are designed to fail under predetermined loads. Always replace shear bolts with identical grade.

^a "Lubricated" means coated with a lubricant such as engine oil, or fasteners with phosphate and oil coatings. "Dry" means plain or zinc plated without any lubrication.

^b Grade 2 applies for hex cap screws (not hex bolts) up to 152 mm (6-in.) long. Grade 1 applies for hex cap screws over 152 mm (6-in.) long, and for all other types of bolts and screws of any length.

Fasteners should be replaced with the same or higher grade. If higher grade fasteners are used, these should only be tightened to the strength of the original.

Make sure fasteners threads are clean and that you properly start thread engagement. This will prevent them from failing when tightening.

Tighten plastic insert or crimped steel-type lock nuts to approximately 50 percent of the dry torque shown in the chart, applied to the nut, not to the bolt head. Tighten toothed or serrated-type lock nuts to the full torque value.

DX.TOR01 -19-20JUL04

METRIC BOLT AND CAP SCREW TORQUE VALUES

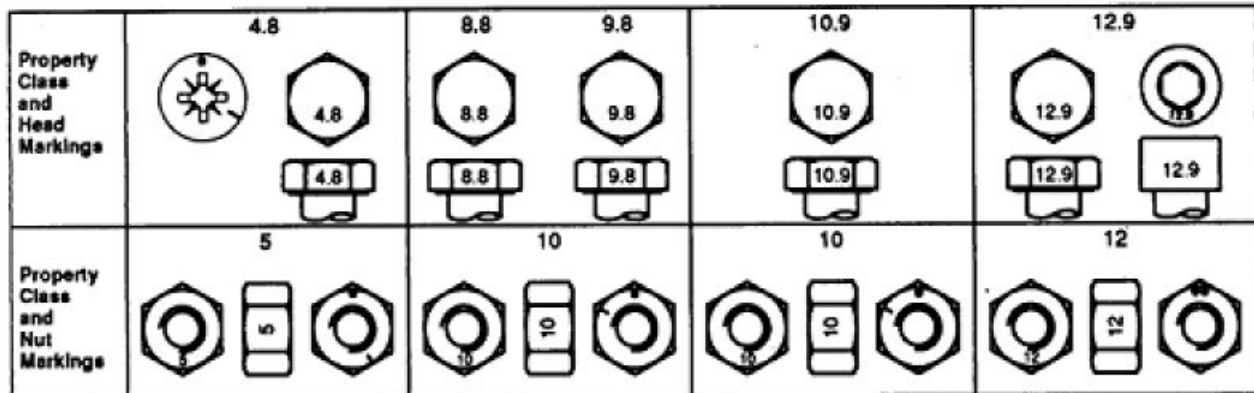

Size	Class 4.8				Class 8.8 or 9.8				Class 10.9				Class 12.9			
	Lubricated*		Dry*		Lubricated*		Dry*		Lubricated*		Dry*		Lubricated*		Dry*	
	N-m	lb-ft	N-m	lb-ft	N-m	lb-ft	N-m	lb-ft	N-m	lb-ft	N-m	lb-ft	N-m	lb-ft	N-m	lb-ft
M6	4.8	3.5	6	4.5	9	6.5	11	8.5	13	9.5	17	12	15	11.5	19	14.5
M8	12	8.5	15	11	22	16	28	20	32	24	40	30	37	28	47	35
M10	23	17	29	21	43	32	55	40	63	47	80	60	75	55	95	70
M12	40	29	50	37	75	55	95	70	110	80	140	105	130	95	165	120
M14	63	47	80	60	120	88	150	110	175	130	225	165	205	150	260	190
M16	100	73	125	92	190	140	240	175	275	200	350	255	320	240	400	300
M18	135	100	175	125	260	195	330	250	375	275	475	350	440	325	560	410
M20	190	140	240	180	375	275	475	350	530	400	675	500	625	460	800	580
M22	260	190	330	250	510	375	650	475	725	540	925	675	850	625	1075	800
M24	330	250	425	310	650	475	825	600	925	675	1150	850	1075	800	1350	1000
M27	490	360	625	450	950	700	1200	875	1350	1000	1700	1250	1600	1150	2000	1500
M30	675	490	850	625	1300	950	1650	1200	1850	1350	2300	1700	2150	1600	2700	2000
M33	900	675	1150	850	1750	1300	2200	1650	2500	1850	3150	2350	2900	2150	3700	2750
M36	1150	850	1450	1075	2250	1650	2850	2100	3200	2350	4050	3000	3750	2750	4750	3500

DO NOT use these values if a different torque value or tightening procedure is given for a specific application. Torque values listed are for general use only. Check tightness of fasteners periodically.

Shear bolts are designed to fail under predetermined loads. Always replace shear bolts with identical property class.

Fasteners should be replaced with the same or higher property class. If higher property class fasteners are used, these should only be tightened to the strength of the original.

* "Lubricated" means coated with a lubricant such as engine oil, or fasteners with phosphate and oil coatings. "Dry" means plain or zinc plated without any lubrication.

Make sure fasteners threads are clean and that you properly start thread engagement. This will prevent them from falling when tightening.

Tighten plastic insert or crimped steel-type lock nuts to approximately 50 percent of the dry torque shown in the chart, applied to the nut, not to the bolt head. Tighten toothed or serrated-type lock nuts to the full torque value.

TUBE•LINE™
MANUFACTURING LTD.