

TA-26 PLUS LOADER TOWER REPLACEMENT PARTS

REF #	PART #	DESCRIPTION	QTY.
1	RAT-412AS - R	TOWER (RIGHT)	1
2	RAT-412AS - L	TOWER (LEFT)	1
3	RT-20AS - R	SLIDE LOCK (RIGHT)	1
4	RT-20AS - L	SLIDE LOCK (LEFT)	1
5	RT-15AS	SHOE	2
6	RAF-324	GREASEABLE PIN	4
7	HHS1011028	5/8" X 1 3/4" BOLT	4
8	CBF1011080	5/8" X 5" CARRIAGE BOLT	4

REF #	PART #	DESCRIPTION	QTY.
9	HTN1011	5/8" LOCK NUT	4
10	LWM10	5/8" LOCK WASHER	4
11	AHS0813010	1/2" X 5/8" SET SCREW	4
12	AHS0813016	1/2" X 1" SET SCREW	2
13	SR-C08	SNAP RING	4
14	ZER1805	GREASE FITTING	4
15	0H059	FRONT WRAP *	1

NOTE: *Varies by Tractor (Standard Front Wrap is 0H059)

WESTENDORFMFG PWB017150

WESTENDORF MFG CO., INC. • PH: (712) 423-2762 • FAX: (712) 423-1460 • sales@westendorfmfg.com • www.loaders.com

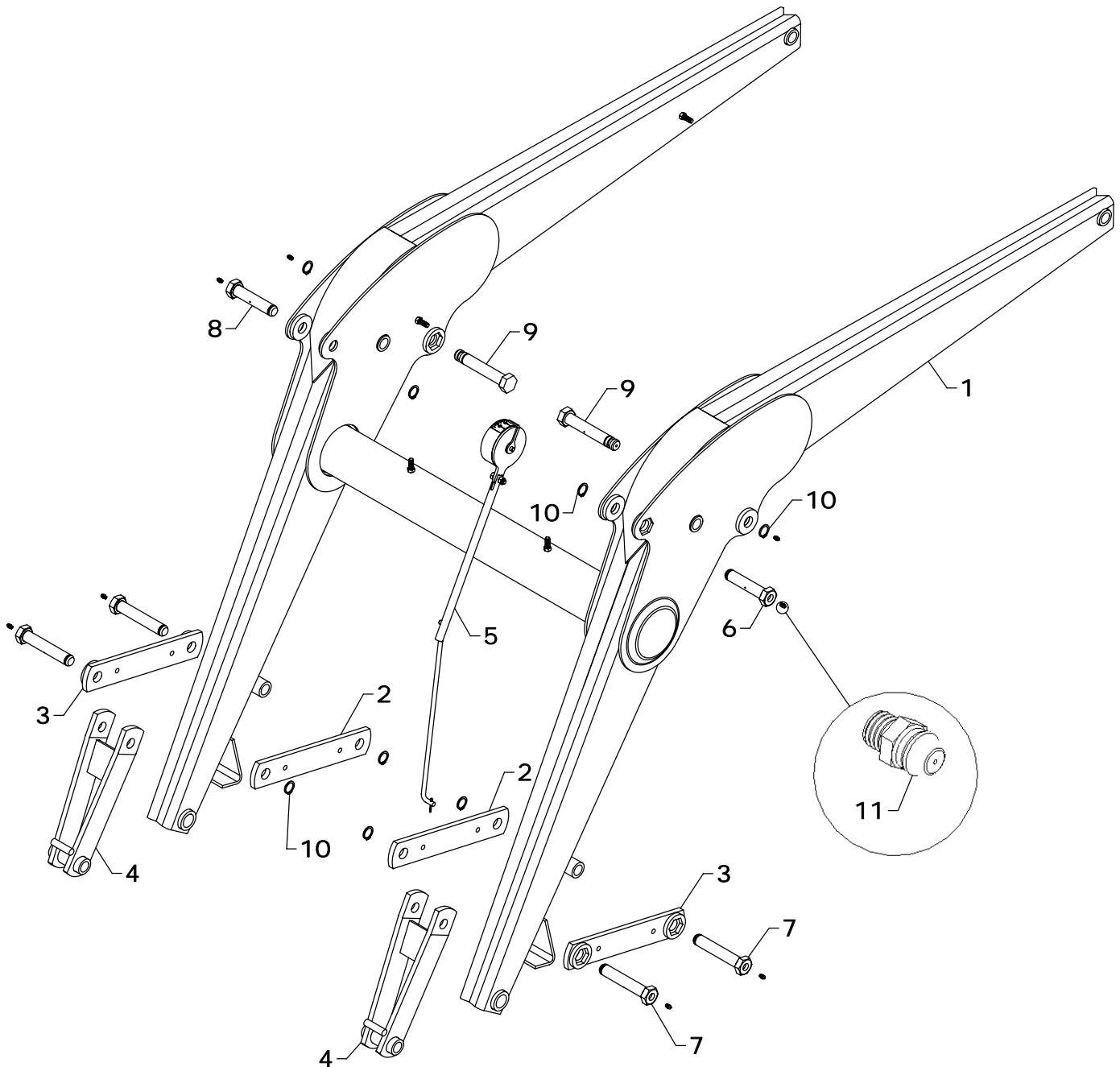

TA-26 PLUS LOADER FRAME REPLACEMENT PARTS

REF #	PART #	DESCRIPTION	QTY
1	RAF-404AS	FRAME	1
2	RAF-10	INSIDE BUCKET PIVOT	2
3	RAF-10AS	OUTSIDE BUCKET PIVOT	2
4	RAF-15AS	BUCKET PIVOT	2
5	LAC-15-04	ROTATIONAL BUCKET INDICATOR	1
6	RAF-224	GREASEABLE PIN	1

REF #	PART #	DESCRIPTION	QTY
7	RAF-226	GREASEABLE PIN	4
8	RAF-324	GREASEABLE PIN	1
9	LF-180	GREASEABLE LIFT PIN	2
10	SR-C08	SNAP RING	8
11	ZER1805	GREASE FITTING	8

NOTE: See page 7.3 for LAC-15-04 parts breakdown.

ROTATIONAL BUCKET INDICATOR

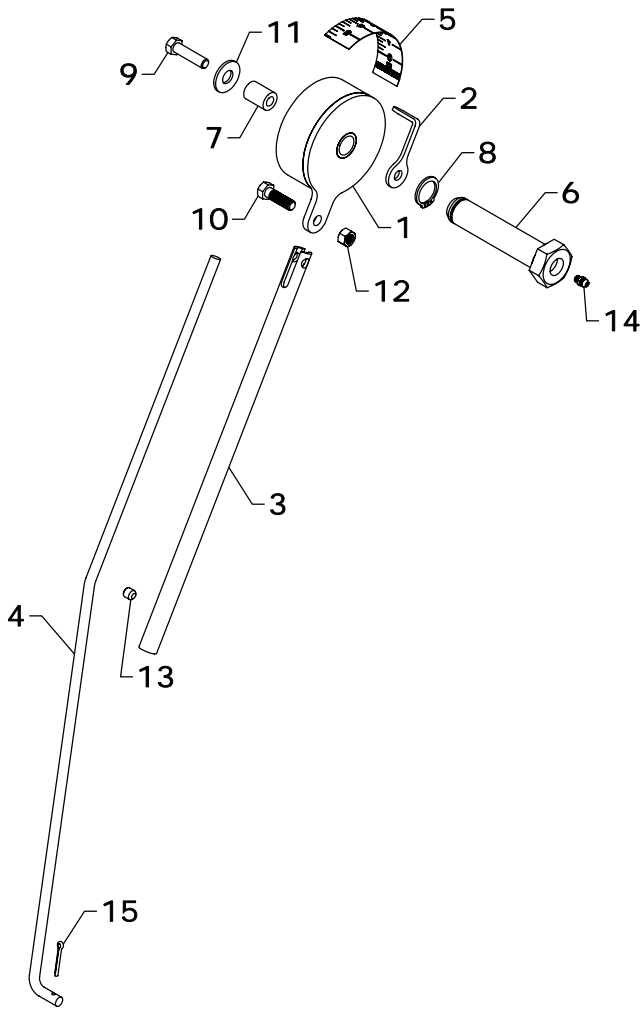

LAC-15-04 (OPTIONAL FOR TA-26)			
REF #	PART #	DESCRIPTION	QTY
1	GRD-121AS	BUCKET INDICATOR	1
2	GRD-123	POINTER	1
3	GRD-105	GAUGE ROD HOLDER	1
4	GRD-125	GAUGE ROD	1
5	DE-GRD	5" RULER	1
6	RAF-224	GREASEABLE PIN	1
7	LM-4	NYLON BUSHING	1
8	SR-C08	SNAP RING	1
9	HHS0616024	3/8" X 1 1/2" BOLT	1
10	HHS0616020	3/8" X 1 1/4" BOLT	1
11	FWW08	1/2" FLAT WASHER	1
12	HTN0616	3/8" LOCK NUT	1
13	AHS0616006	3/8" X 3/8" ALLEN HEAD SET SCREW	1
14	ZER1805	GREASE FITTING	1
15	CTK0200016	1/8" X 1" COTTER KEY	1

*NOTE: *Order LAC-15-04 when ordering a complete Rotational Bucket Indicator Kit.*

ROTATIONAL HEIGHT INDICATOR

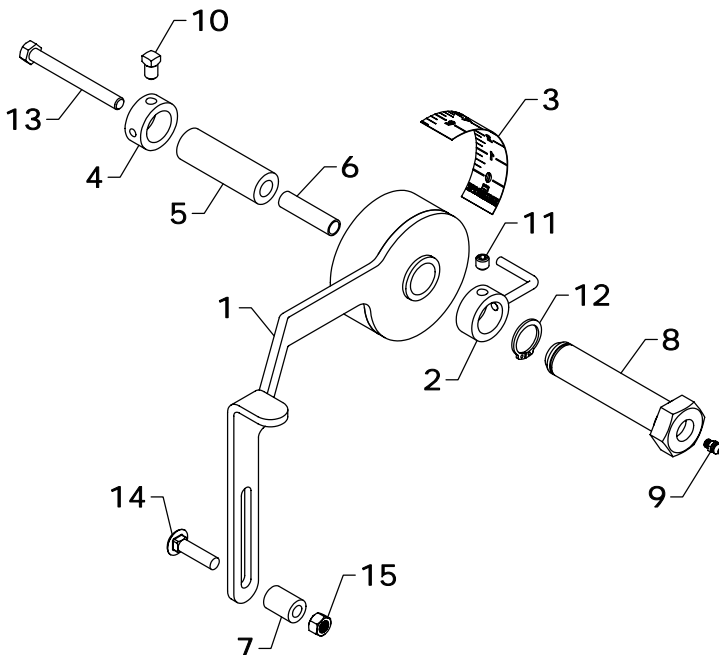

LAC-25-09 (OPTIONAL FOR TA-26 & TA-26 PLUS)			
REF #	PART #	DESCRIPTION	QTY
1	GRD-11AS	HEIGHT INDICATOR	1
2	GRD-2AS	POINTER	1
3	DE-GRD	5" RULER	1
4	BUS-105	BUSHING	1
5	BUS-106	BUSHING	1
6	BUS-107	INSERT BUSHING	1
7	LM-4	NYLON BUSHING	1
8	RAF-224	GREASEABLE PIN	1
9	ZER1805	GREASE FITTING	1
10	SHS0616008	3/8" X 1/2" SQUARE HEAD SET SCREW	1
11	AHS0616006	3/8" X 3/8" ALLEN HEAD SET SCREW	1
12	SR-C08	SNAP RING	1
13	HHS0616056	3/8" X 3 1/2" BOLT	1
14	CBF0616024	3/8" X 1 1/2" CARRIAGE BOLT	1
15	HTN0616	3/8" LOCK NUT	1

*NOTE: *Order LAC-25-09 when ordering a complete Rotational Height Indicator Kit.*

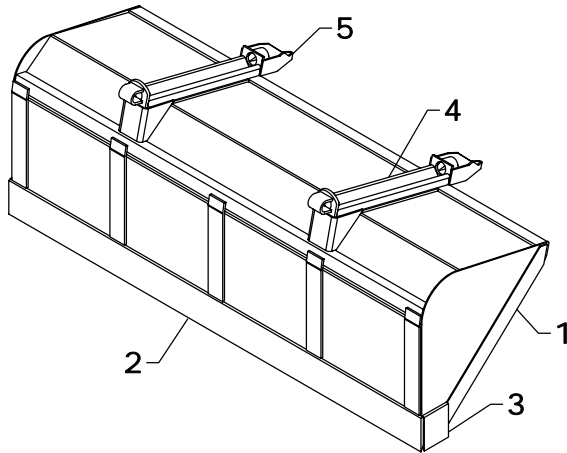

BUCKET

REF #	PART #	DESCRIPTION	QTY.
1	72Q214	72" BUCKET	1
	84Q216	84" BUCKET	1
2	JB-14	72" BLADE	1
	SB-14	84" BLADE	1
3	SB-15	BLADE	2
4	QC-13AS	WELD ON ADAPTER	2
5	JB-22	GUIDE (OPTIONAL)	2

NOTE: *Check width of the bucket and use the part number that matches. If your size is not shown, contact Westendorf Mfg. Co.

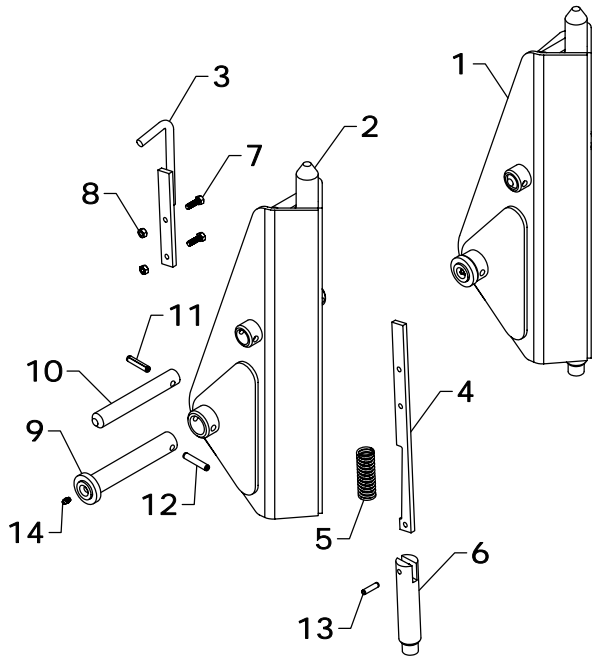

SNAP-ATTACH™ COUPLER (C-4B)

FOR USE WITH TA-26 PLUS & TA-26 ¹²			
REF #	PART #	DESCRIPTION	QTY.
1	QC-1201COM	MALE COUPLER	1
2	QC-1201AS	MALE COUPLER	1
3	QC-6AS	LATCH HANDLE	1
4	QC-8	LATCH	1
5	QC-12	SPRING	1
6	QC-3	BOTTOM LATCH PIN	1
7	HHS0518016	5/16" X 1" BOLT	2
8	HTN0518	5/16" LOCK NUT	2
9	XAF-55AS	LINKAGE PIN	1
10	LF-51	LINKAGE PIN	1
11	DRP0600028	DOUBLE ROLL PIN	1
12	DRP0600032	DOUBLE ROLL PIN	1
13	RLP0500020	5/16" X 1 1/4" ROLL PIN	1
14	ZER1805	GREASE FITTING	1

NOTE: Qty. shows number of parts received if ordered using listed part numbers.
C-4B is two (QC-1201COM) couplers.

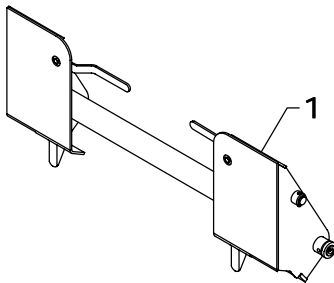

C-30 SKID STEER COUPLER

REF #	PART #	DESCRIPTION	QTY.
1	C-30	SKID STEER COUPLER (OPTIONAL)	1

COSMETICS

REF #	PART #	DESCRIPTION	QTY.
1	DEC-26PLUS	DECAL KIT	1
2	V-5403-A	RED SPRAY PAINT	1
	V-19040-A	BRIGHT BLACK SPRAY PAINT	1
3	V-5403-P	PINT RED PAINT	1
	V-19040-P	PINT BRIGHT BLACK PAINT	1

REF #	PART #	DESCRIPTION	QTY.
4	V-5403-Q	QUART RED PAINT	1
	V-19040-Q	QUART BRIGHT BLACK PAINT	1
5	V-5403-G	GALLON RED PAINT	1
	V-19040-G	GALLON BRIGHT BLACK PAINT	1

NOTE: Warning decals are available at no charge. If they become damaged or missing, order part numbers DE-LDI, DE-DWW, DE-WWW, DE-TA7, DE-PP, DE-QC, and DE-QCC.

WESTENDORFMFG PWB017150

WESTENDORF MFG. CO., INC. • PH: (712) 423-2762 • FAX: (712) 423-1460 • sales@westendorfmfg.com • www.loaders.com

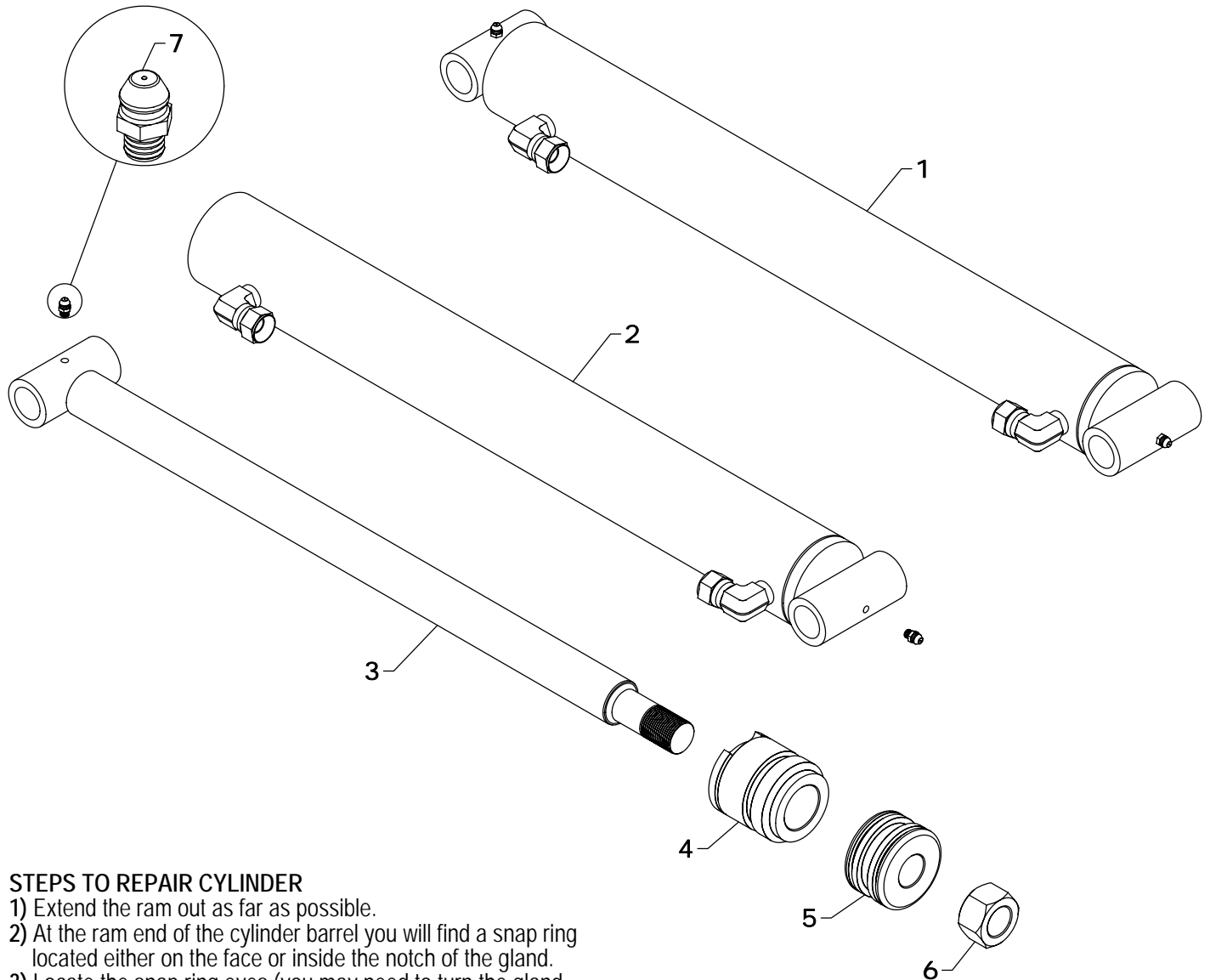

STEPS TO REPAIR CYLINDER

- 1) Extend the ram out as far as possible.
- 2) At the ram end of the cylinder barrel you will find a snap ring located either on the face or inside the notch of the gland.
- 3) Locate the snap ring eyes (you may need to turn the gland inside the barrel to find the snap ring eyes). Compress the snap ring with snap ring pliers.
- 4) Remove the ram assembly (ram, gland, & piston) from barrel.
- 5) Notice the direction they're pointing so they can be properly re-assembled.
- 6) Remove the jam nut and/or hex nut from the end of the ram.
- 7) Remove the old seals and rings and replace them with the new seals and rings. (Seal kits are packaged for several different cylinders. You may have extra parts)
- 8) Clean cylinder with cleaner and a clean lint free cloth.
- 9) Lubricate the seals and rings to aid assembly.
- 10) Assemble the cylinder by reversing the order.

CYLINDER REPAIR TIPS

- When disassembling cylinders, keep the parts in correct orientation. Remove parts in sequence.
- Note the direction of the piston and gland. Lay out old seals and parts as they are removed.
- Assemble cylinder in proper order; lubricate to aid assembly.

BUCKET CYLINDER REPLACEMENT PARTS

REF #	PART #	DESCRIPTION	QTY.
1	B-10	BUCKET CYLINDER	1
2	B-1001	BARREL	1
3	B-1010	RAM	1
4	G-A	GLAND	1
5	P-A	PISTON	1
6	HFN1614	1" NUT	1
7	ZER1805	GREASE FITTING	2
8	#1CK	REPAIR KIT *	1

*NOTE: * Repair kit contains parts to repair one cylinder*

WESTENDORFMFG PWB017150

WESTENDORF MFG. CO., INC. • PH: (712) 423-2762 • FAX: (712) 423-1460 • sales@westendorfmfg.com • www.loaders.com

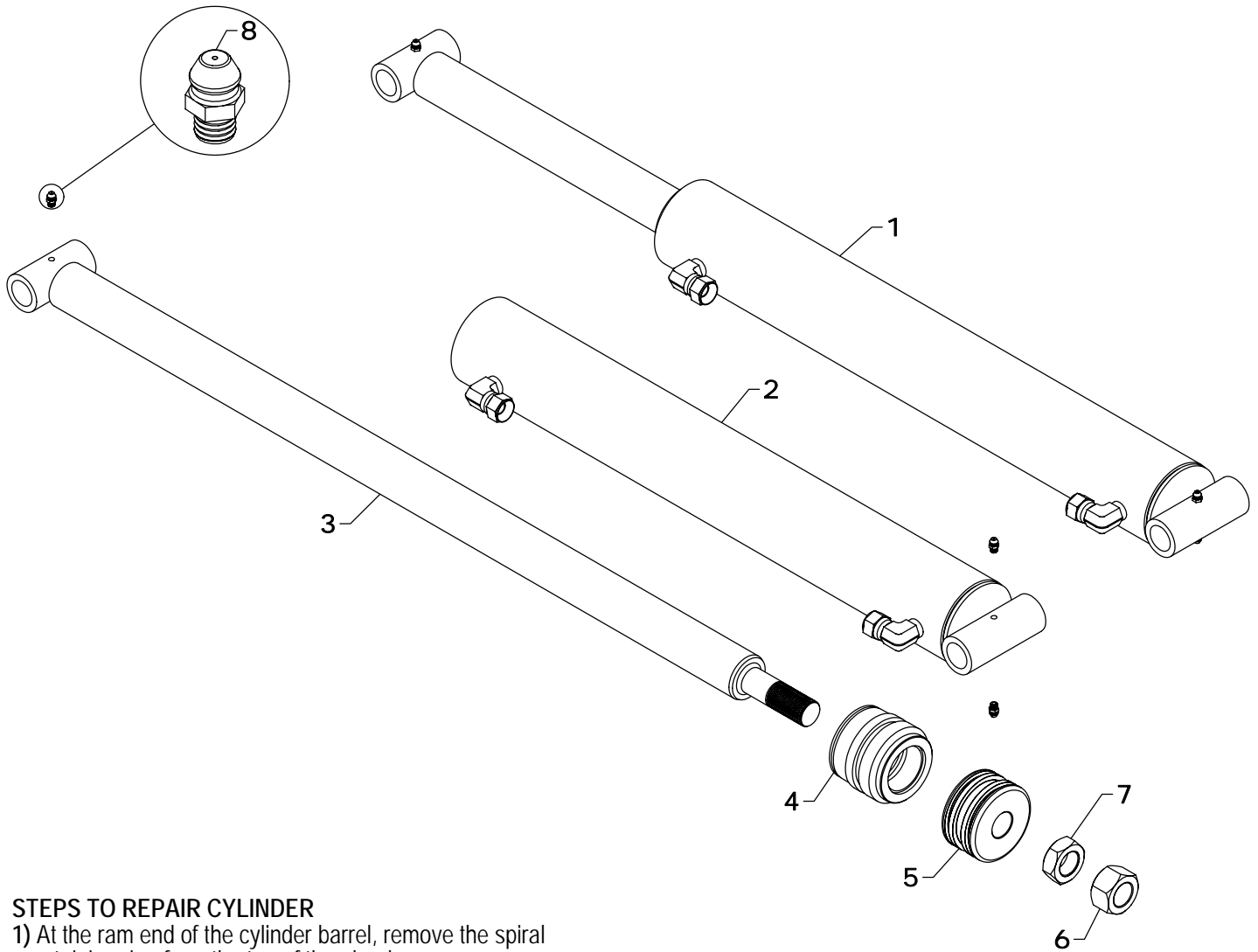

STEPS TO REPAIR CYLINDER

- 1) At the ram end of the cylinder barrel, remove the spiral retaining ring from the top of the gland.
NOTE: The G-E gland does not use the spiral retaining ring.
- 2) Gently drive the gland into the barrel using a brass or non-marring punch until the round retaining ring is visible.
- 3) Remove the round retaining ring using a pair of long nose pliers. Remove the ram assembly (ram, gland, and piston) from the barrel.
- 4) Notice the direction they're pointing so they can be properly re-assembled.
- 5) Remove the jam nut and/or hex nut from the end of the ram.
- 6) Remove the old seals and rings and replace them with the new seals and rings. (Seal kits are packaged for several different cylinders. You may have extra parts)
- 7) Clean cylinder with cleaner and a clean lint free cloth.
- 8) Lubricate the seals and rings to aid assembly.
- 9) Assemble the cylinder by reversing the order.

CYLINDER REPAIR TIPS

- When disassembling cylinders, keep the parts in correct orientation. Remove parts in sequence.
- Note the direction of the piston and gland. Lay out old seals and parts as they are removed.
- Assemble cylinder in proper order; lubricate to aid assembly.

LIFT CYLINDER REPLACEMENT PARTS

REF #	PART #	DESCRIPTION	QTY.
1	L-18	LIFT CYLINDER	1
2	L-1801	BARREL	1
3	L-1810	RAM	1
4	G-L	GLAND	1
5	P-B	PISTON	1
6	HFN1614	1" NUT	1
7	HJN1614	1" JAM NUT	1
8	ZER1805	GREASE FITTING	3
9	#4CK	REPAIR KIT *	1

NOTE: * Repair kit contains parts to repair one cylinder

WESTENDORFMFG PWB017150

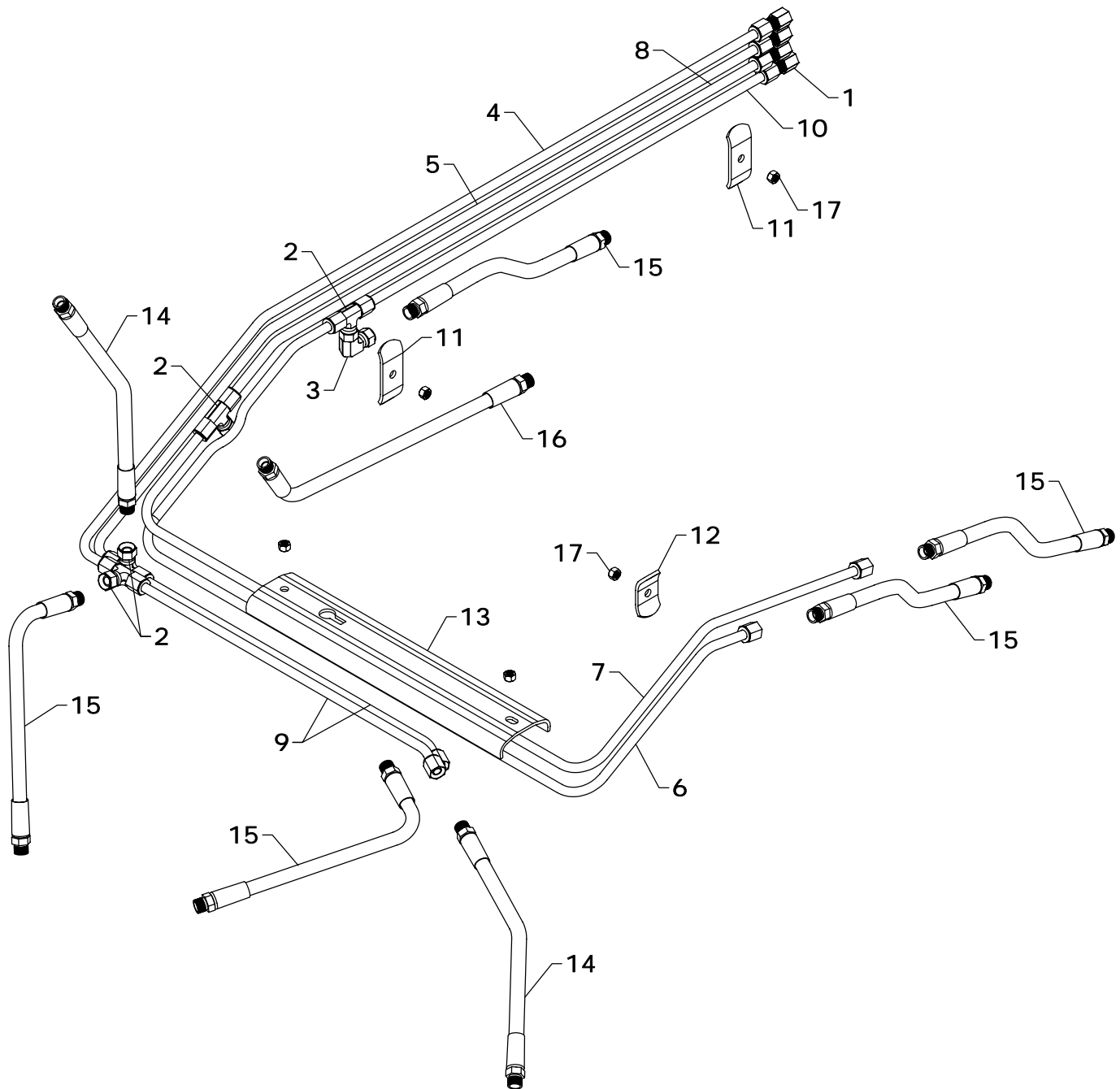

TA-26 & TA-26 PLUS HYDRAULIC LINES

REF #	PART #	DESCRIPTION	QTY.
1	PF-FFC8	FEMALE CONNECTOR	4
2	PF-FSBT8	SWIVEL NUT TEE	4
3	PF-FSE8	90° SWIVEL NUT ELBOW	1
4	OLT-132	OIL LINE	1
5	OLT-133	OIL LINE	1
6	OLT-630	OIL LINE	1
7	OLT-631	OIL LINE	1
8	OLT-632	OIL LINE	1
9	OLT-633	OIL LINE	2

REF #	PART #	DESCRIPTION	QTY.
10	OLT-634	OIL LINE	1
11	OH-3	OIL LINE HOLDER	2
12	OH-6	OIL LINE HOLDER	1
13	OH-9	OIL LINE HOLDER	1
14	H06015-FF	3/8" X 15" HOSE	2
15	H06020-FF	3/8" X 20" HOSE	5
16	H06030-FF	3/8" X 30" HOSE	1
17	HTN0616	3/8" LOCK NUT	5

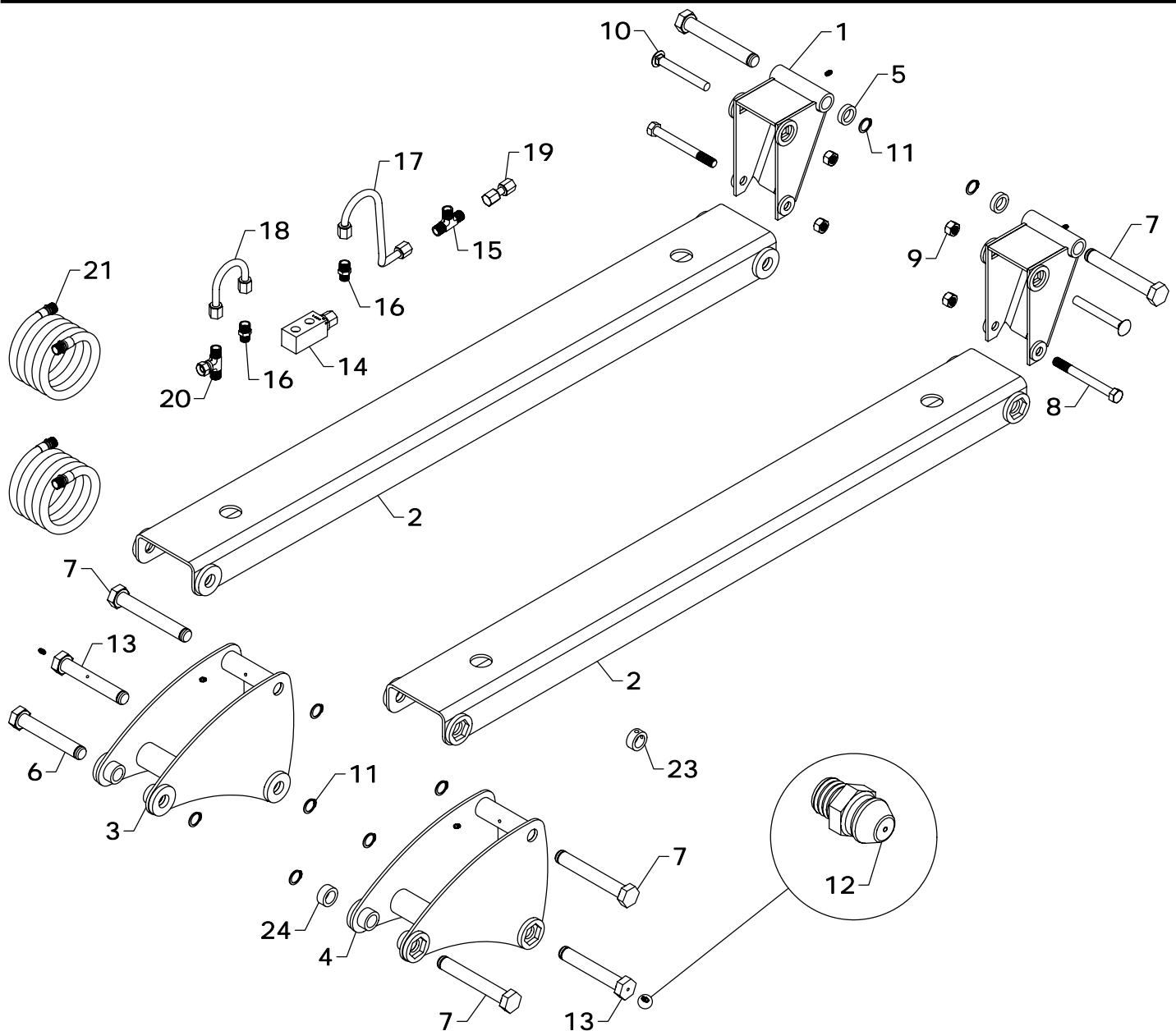

OPTIONAL ADD-ON SELF LEVELING KIT FOR TA-26 & TA-26 PLUS

KSL-21			
REF #	PART #	DESCRIPTION	QTY
1	RAT-26AS	SELF LEVELING BRACKET	2
2	RAF-23AS	LEVELING LINKAGE BAR	2
3	RAF-429AS - R	HINGE PLATE (RIGHT)	1
4	RAF-429AS - L	HINGE PLATE (LEFT)	1
5	RAT-30	SPACER BUSHING	2
6	RAF-38	PIVOT PIN	1
7	RAF-41	SELF LEVELING PIN	5
8	HHS1011096	5/8" X 6" BOLT	2
9	HTN1011	5/8" LOCK NUT	4
10	CBF1011080	5/8" X 5" CARRIAGE BOLT	2
11	SR-C08	SNAP RING	8
12	ZER1805	GREASE FITTING	6

KSL-21			
REF #	PART #	DESCRIPTION	QTY
13	RAF-39	PIVOT PIN	2
14	SLV-2A	RELIEF VALVE	1
15	PF-8-JU-S	TEE	1
16	PF-FMC0608	MALE CONNECTOR	2
17	OLT-150	OIL LINE	1
18	OLT-654	OIL LINE	1
19	OLT-439	OIL LINE	1
20	PF-FSBT8	SWIVEL NUT TEE	1
21	H06030-FF	3/8" X 30" HOSE	2
22	DEC-SL1M	DECAL KIT (NOT SHOWN)	1
23	BUS-105	BUSHING	1
24	BF-60	SPACER BUSHING	1

WESTENDORFMFG PWB017150

WESTENDORF MFG CO., INC. • PH: (712) 423-2762 • FAX: (712) 423-1460 • sales@westendorfmfg.com • www.loaders.com

ROTATIONAL BUCKET INDICATOR

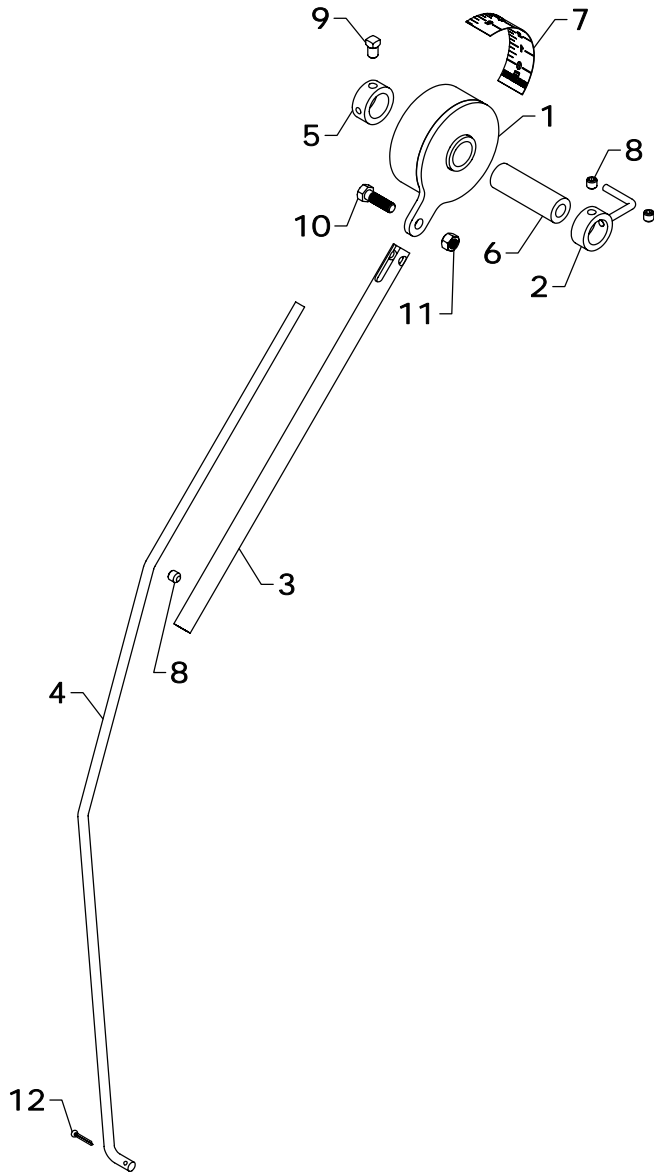

LAC-15-23 (OPTIONAL - USE WITH KSL-21 KIT)			
REF #	PART #	DESCRIPTION	QTY.
1	GRD-101AS	BUCKET INDICATOR	1
2	GRD-2AS	POINTER	1
3	GRD-105	GAUGE ROD HOLDER	1
4	GRD-155	GAUGE ROD	1
5	BUS-105	BUSHING	1
6	BUS-106	BUSHING	1
7	DE-GRD	5" RULER	1
8	AHS0616006	3/8" X 3/8" ALLEN HEAD SET SCREW	3
9	SHS0616008	3/8" X 1/2" SQUARE HEAD SET SCREW	1
10	HHS0616020	3/8" X 1 1/4" BOLT	1
11	HTN0616	3/8" LOCK NUT	1
12	CTK0200016	1/8" X 1" COTTER KEY	1

*NOTE: *Order LAC-15-23 when ordering a complete Rotational Bucket Indicator Kit.*

ROTATIONAL HEIGHT INDICATOR

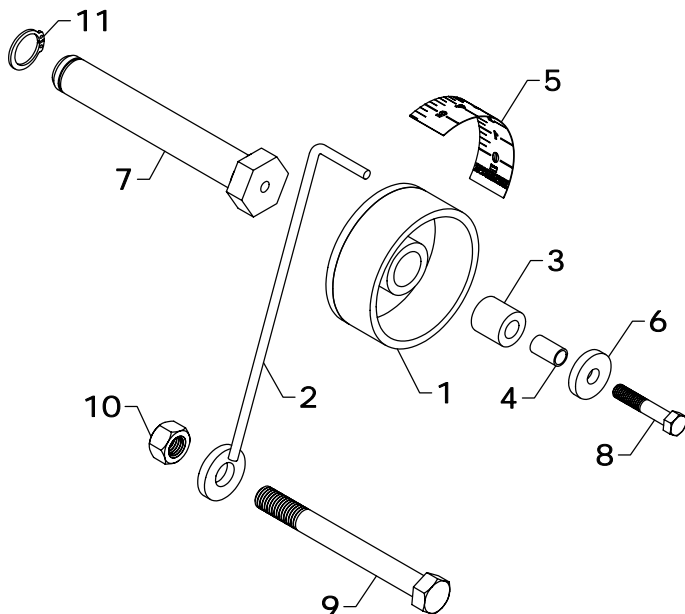

LAC-25-16 (OPTIONAL - USE WITH KSL-21 KIT)			
REF #	PART #	DESCRIPTION	QTY.
1	GRD-23AS	HEIGHT INDICATOR	1
2	GRD-22AS	POINTER	1
3	BUS-163	BUSHING	1
4	BUS-164	INSERT BUSHING	1
5	DE-GRD	5" RULER	1
6	MF-47	GAUGE ROD WASHER	1
7	RAF-141	SELF LEVELING PIN	1
8	HHS0616032	3/8" X 2" BOLT	1
9	HHS1011096	5/8" X 6" BOLT	1
10	HTN1011	5/8" LOCK NUT	1
11	SR-C08	SNAP RING	1

*NOTE: *Order LAC-25-16 when ordering a complete Rotational Height Indicator Kit.*

WESTENDORFMFG PWB017150