

- NOTES: 1.) MAT'L - 1X2-1/2 FLAT 5160; HARDNESS - ROCKWELL C 42-46  
 2.) FINISH - NONE  
 3.) PART TO BE SHOT PEENED TO ALMEN C-7 MINIMUM IN AREA NOTED  
 4.) FINISHED PART - 24354

DWG NO. 52603

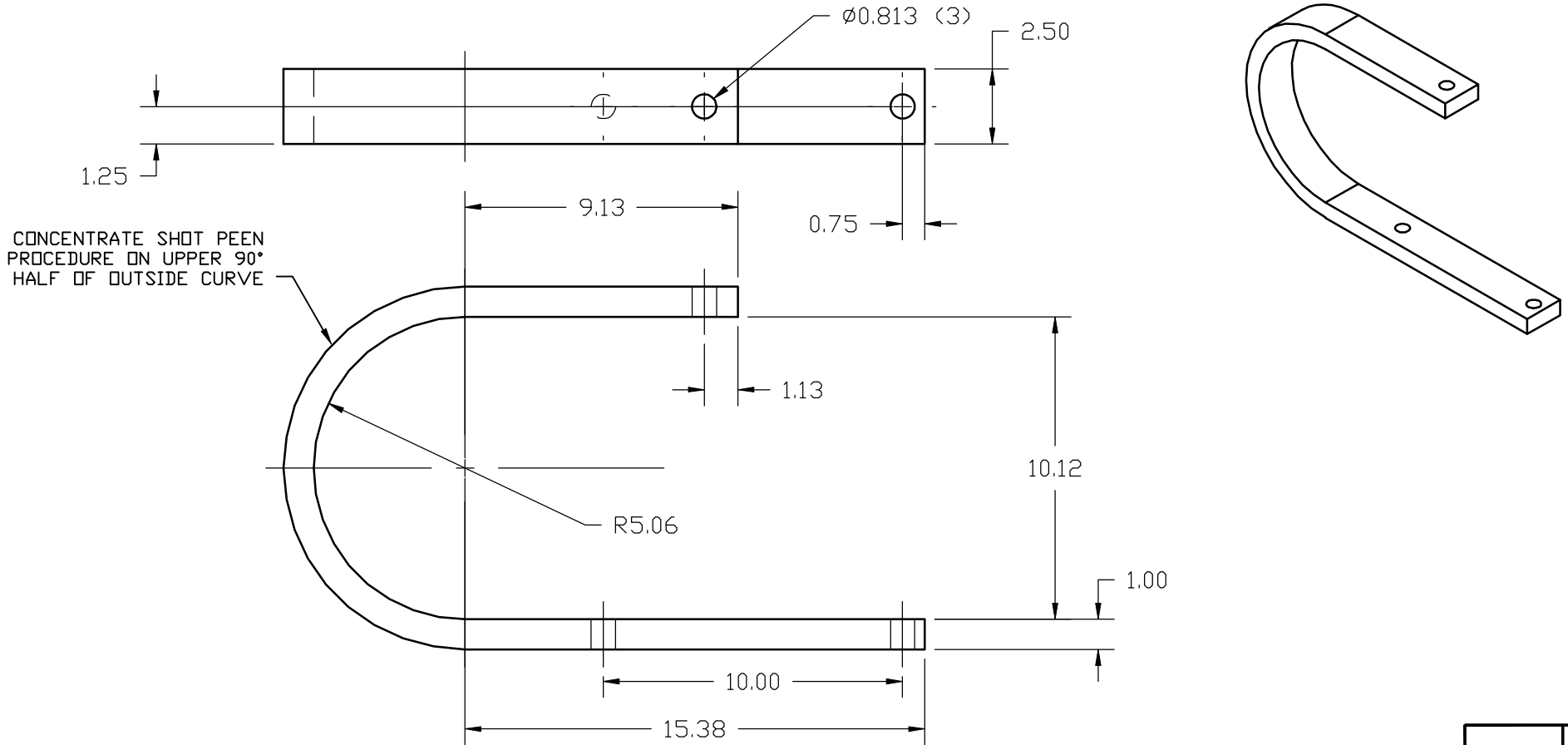

				MATERIAL	PPP	STD MIL TOL UNLESS SPEC.	
				TOLERANCE UNLESS SPECIFIED DECIMAL: .X $\pm 0.06$ [1,5] .XX $\pm 0.03$ [0,8] .XXX $\pm 0.015$ [0,38] HOLE DIA: $-0.005 +0.015$ [-0,13 +0,38] ANGLES: $\pm 1.5^\circ$ METRIC: [ ] DO NOT SCALE THIS DRAWING REMOVE ALL SHARP EDGES		WIL-RICH LLC	
051506	TLK	5-15	B	WAS PAINT BLACK		SPRING SHANK	
048512	ADM	4/85	A	RELEASE			
EO	BY	DATE	LTR	REVISION	ITEM CLS -	PREP	CHK
						ALR 8-17-05	ALR
				APVD	ALR	SCALE	NONE
				DWG NO.	52603		

TSC — NOTICE: WIL-RICH LLC claims proprietary rights to the information disclosed on this drawing. It is issued in confidence for engineering information only, and may not be reproduced or used to manufacture anything shown hereon without direct written permission from WIL-RICH LLC to the user.