

AGRICULTURAL MACHINERY

**sitrex**®  
Spa

## ASSEMBLY, USE AND MAINTENANCE SPARE PARTS LIST

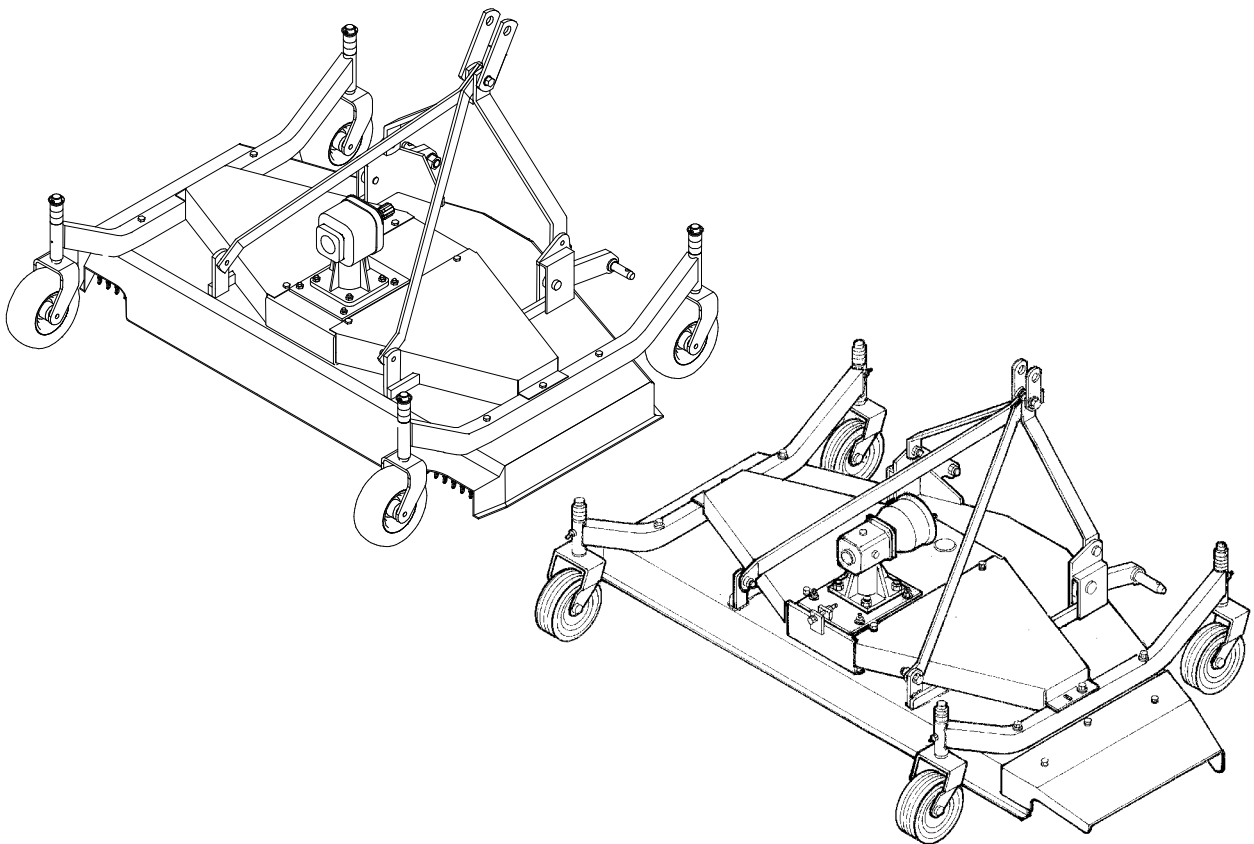

# FINISHING MOWERS

## SM 120 -150 -180



---

# TABLE OF CONTENT

<b>CHAPTER 1</b>	<b>GENERAL INTRODUCTION - WARRANTY .....</b>	<b>2</b>
1.1	INTRODUCTION .....	3
1.2	WARRANTEE .....	3
<b>CHAPTER 2</b>	<b>GUIDE TO THE SIGNS AND SYMBOLS USED IN THIS MANUAL AND THEIR LOCATION ON THE MACHINE.....</b>	<b>4</b>
2.1	SIGNS AND SYMBOLS .....	5
2.2	WARNING SIGNS .....	5
2.3	DANGER SIGNS .....	6
2.4	INDICATION SIGNS .....	8
2.5	LOCATION OF SIGNS AND SYMBOLS ON THE MACHINE .....	9
<b>CHAPTER 3</b>	<b>GENERAL SUMMARY OF SAFETY AND ACCIDENT - PREVENTION INSTRUCTIONS .....</b>	<b>10</b>
3.1	GENERAL SUMMARY OF SAFETY AND ACCIDENT-PREVENTION INSTRUCTIONS .....	11
<b>CHAPTER 4</b>	<b>PRODUCT IDENTIFICATION .....</b>	<b>14</b>
4.1	TECHNICAL DATA .....	15
4.2	MAIN MACHINE PARTS .....	15
<b>CHAPTER 5</b>	<b>DELIVERY AND ASSEMBLY .....</b>	<b>16</b>
5.1	CHECKING THE MACHINE ON DELIVERY .....	17
5.2	ASSEMBLY SEQUENCE .....	21
5.3	SPECIAL MODELS .....	29
<b>CHAPTER 6</b>	<b>ADJUSTMENT, PREPARATION AND USE.....</b>	<b>31</b>
6.1	INTRODUCTION .....	32
6.2	MOUNTING TO THE TRACTOR .....	32
6.3	CONNECTING THE CARDAN SHAFT .....	33
6.4	TRANSPORT BY ROAD .....	34
6.5	GENERAL INSTRUCTIONS FOR FIELD USE .....	34
6.6	GENERAL INSTRUCTIONS FOR USE .....	35
<b>CHAPTER 7</b>	<b>MAINTENANCE .....</b>	<b>42</b>
7.1	MAINTENANCE DIRECTIONS .....	43
7.2	REPAIR INSTRUCTIONS .....	44
7.3	LAYING UP FOR EXTENDED PERIODS .....	44
7.4	MAINTENANCE AND TESTING .....	45
7.5	MAINTENANCE POINTS .....	46
7.6	CARDAN SHAFT MAINTENANCE .....	47
7.7	NOISE AND VIBRATION .....	48
7.8	SCRAPPING THE MACHINE .....	48
<b>CHAPTER 8</b>	<b>SPARE PARTS LIST .....</b>	<b>49</b>
8.1	REAR DISCHARGE FINISHING MOWER .....	50
8.2	LATERAL DISCHARGE FINISHING MOWER .....	52
8.3	MULTIPLIER GEARBOX .....	54
8.4	SPECIAL MODELS .....	55
8.5	COMPLETE WHEEL .....	56
8.6	CARDAN SHAFT (E2 090 E) .....	57
8.7	CARDAN SHAFT (B2 090 B) .....	58
8.8	ANTI-SCALPING ROLLER KIT (OPTIONAL) .....	59
8.9	REAR DISCHARGE MULCHING KIT (OPTIONAL) .....	Errore. Il segnalibro non è definito.
8.10	LATERAL DISCHARGE MULCHING KIT (OPTIONAL) .....	Errore. Il segnalibro non è definito.

## CHAPTER 1

### GENERAL INTRODUCTION - WARRANTY

## 1.1 INTRODUCTION



The user of the lawn mower (later referred to as the "machine") is responsible for his own safety as well as that of the people in proximity of it.

It is therefore crucial that the user has detailed information on the use and maintenance of the machine and on how to connect it correctly to a tractor.

This machine can operate only through a Cardan shaft attached to the power takeoff of an agricultural tractor equipped with a lifting unit and 3-point universal linkage. This manual is intended both for the operator and those responsible for maintenance. Essential instructions and procedures to follow during use and maintenance of the machine are conveyed through drawings and text.

The user is responsible for ensuring that the machine is connected to the tractor and is operated in compliance with current legal provisions.

The machine must only be operated and maintained by persons who have read this manual. The manual should always be kept to hand. It is particularly important to read CHAPTER 3 on general safety instructions. These instructions must always be heeded.

If you are in any doubt, contact the Assistance Center or your nearest dealer.

## 1.2 WARRANTEE

On delivery, check that the machine has not been damaged during transport and that all the attachments are present. Claims must be made in writing to the agent within 8 days of receipt.

The manufacturer warrants new machinery at the time of delivery to the original purchaser to be free from defects in material and workmanship if properly set up and operated in accordance with this Operator's Manual.

The manufacturer undertakes to repair or replace free of charge any defective part which should be returned by the purchaser (freight prepaid) and found to be defective by inspection authorized by The manufacturer during the warranty period.

This warranty will be valid for 12 (twelve) months from the delivery of goods to the original purchaser.

In case the customer is not in a position to return the defective part to the manufacturer, the manufacturer cannot be held responsible for any cost due for repair or replacement of any part of the machine, he will only supply the part(s) required for the repair and/or replacement.

The warranty is null and void when it is evident that the machine has been improperly used or repaired or however repaired without authorization.

The manufacturer undertakes no responsibility for any obligation or agreement reached by any employers, agents or dealers, which are not in compliance with the above warranty. The manufacturer cannot be held responsible for the consequent damages. This warranty substitutes any other warranty, express or implied, and any other manufacturer's obligation.

## CHAPTER 2

### GUIDE TO THE SIGNS AND SYMBOLS USED IN THIS MANUAL AND THEIR LOCATION ON THE MACHINE

## 2.1 SIGNS AND SYMBOLS

These signs and symbols give information to the operator on how to make the best use of the machine so as to prolong life, avoid damage, optimize work and, above all, to avoid injury to the operator and anyone within range of the machine.

### 2.2 WARNING SIGNS

1. Before beginning operations, read the instruction manual carefully.

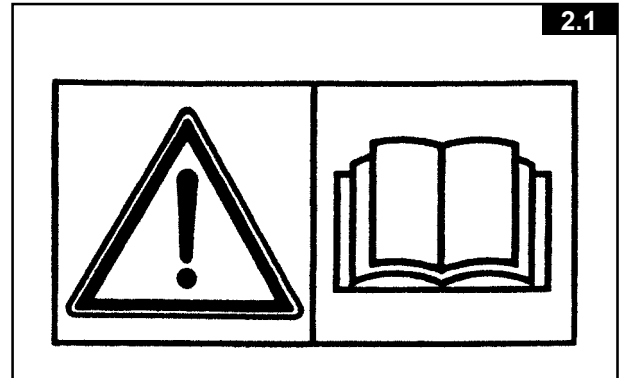

2. Prior to any maintenance work, adjustments or repairs, stop the machine, set it on the ground, turn off tractor and apply parking brake. Remove key from ignition and consult the instructions and maintenance manual.

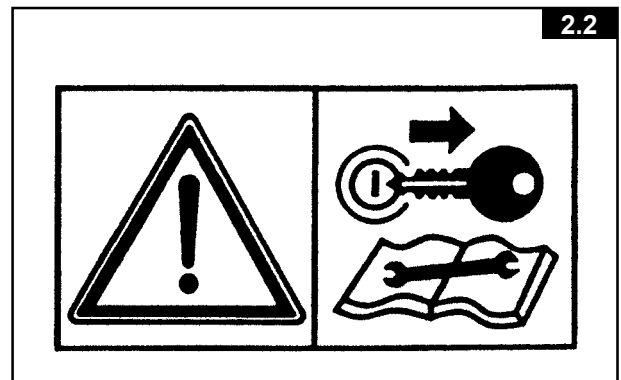

3. This is a warning to use proper accident protection when carrying out maintenance and repairs

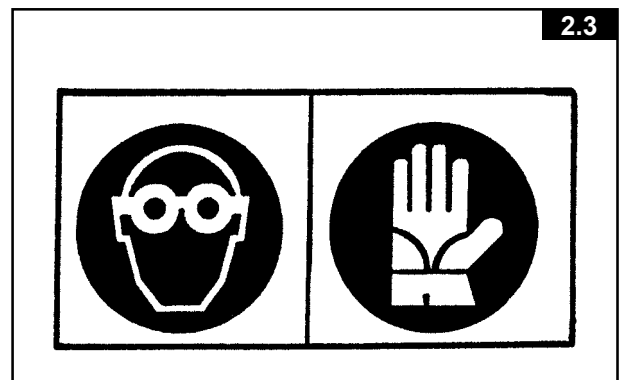

4. Warns the danger of cutting blade

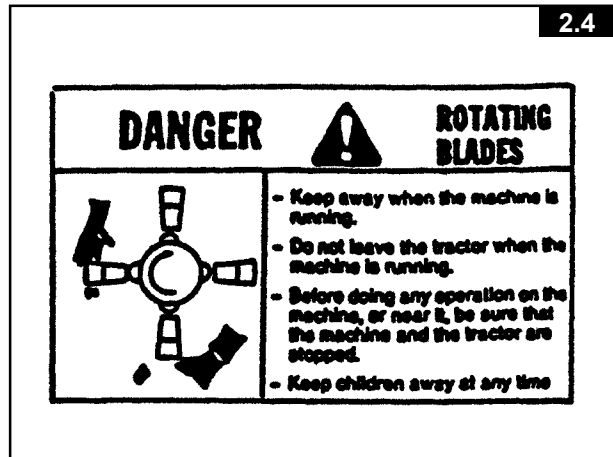

5. This sign is a reminder to check the oil level.

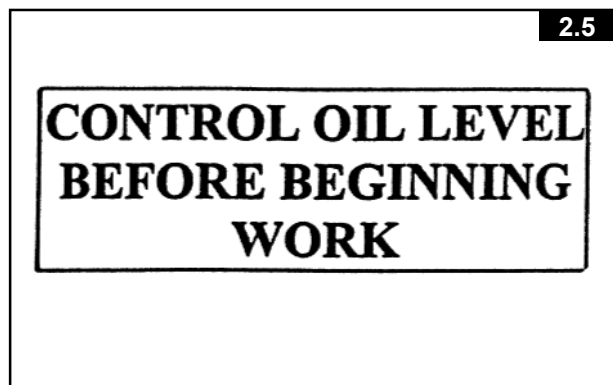

### 2.3 DANGER SIGNS

6. Indicates an impending dangerous situation which, if not avoided, will cause death or severe personal injury.



7. General danger

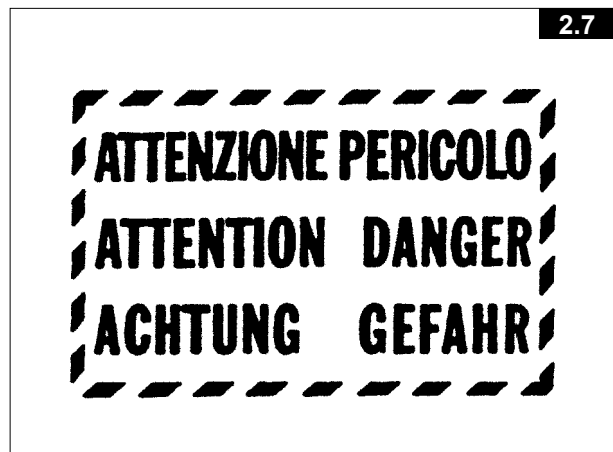



8. This indicates a potential danger which, if not avoided, could cause serious personal injury. It also indicates danger when removing protective guards.



9. Indicates a potentially dangerous situation which, if not avoided, can provoke less severe or minor injuries.



10. Risk of possible ejection of blunt objects. Keep a safe distance from the machine.

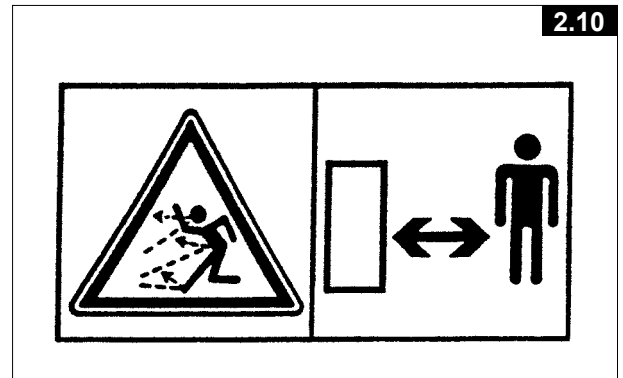

11. This indicates the risk of cutting one's foot. Keep at a safe distance.

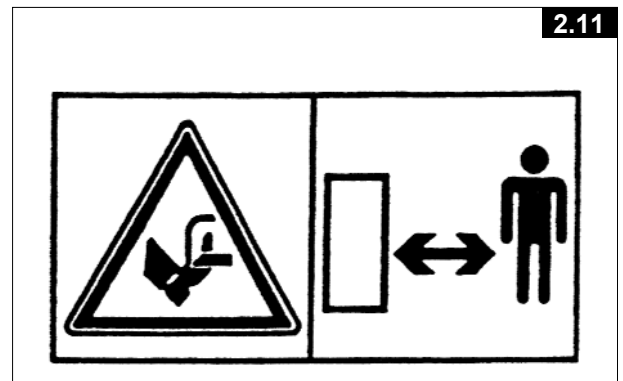

12. This indicates the risk of cutting one's hand. Keep at a safe distance.

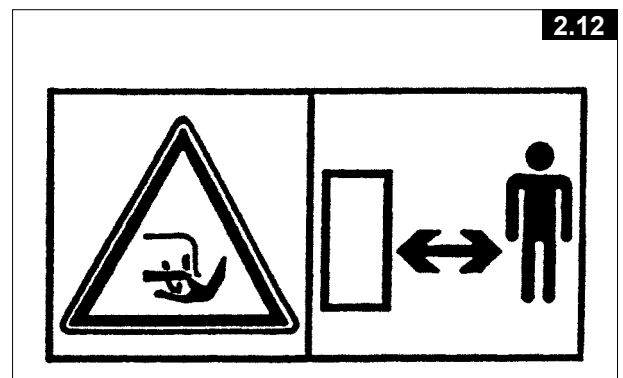

13. Indicates that it is dangerous to touch the Cardan shaft. For all other information regarding the Cardan shaft, see the use-and-maintenance booklet specifically for the Cardan shaft which, together with this manual, makes up the documentation on safety, use and maintenance of the machine.



## 2.4 INDICATION SIGNS

14. This indicates the oil level

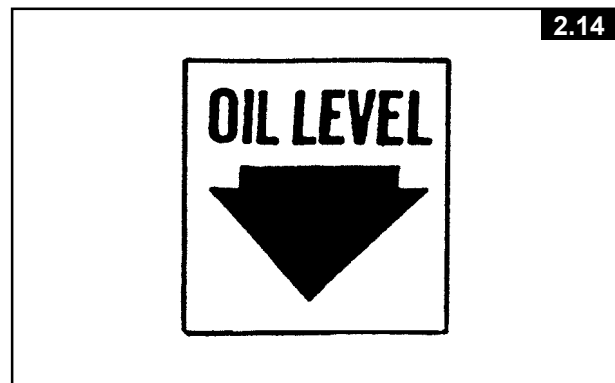

15. Indicates a greasing point.

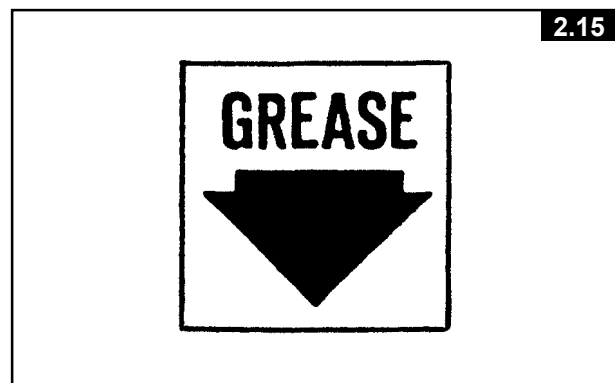

16. Shows the direction of rotation of the power takeoff and the maximum number of revolutions.

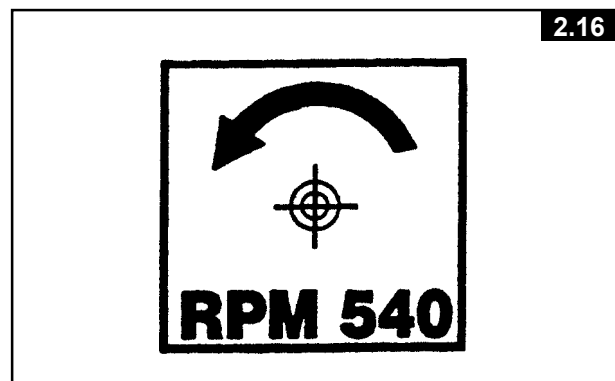

**NOTE:** All the signs and symbols so far shown appear in the manual. Some of these are also on the machine: for their location, the diagram on page 9.

## 2.5 LOCATION OF SIGNS AND SYMBOLS ON THE MACHINE

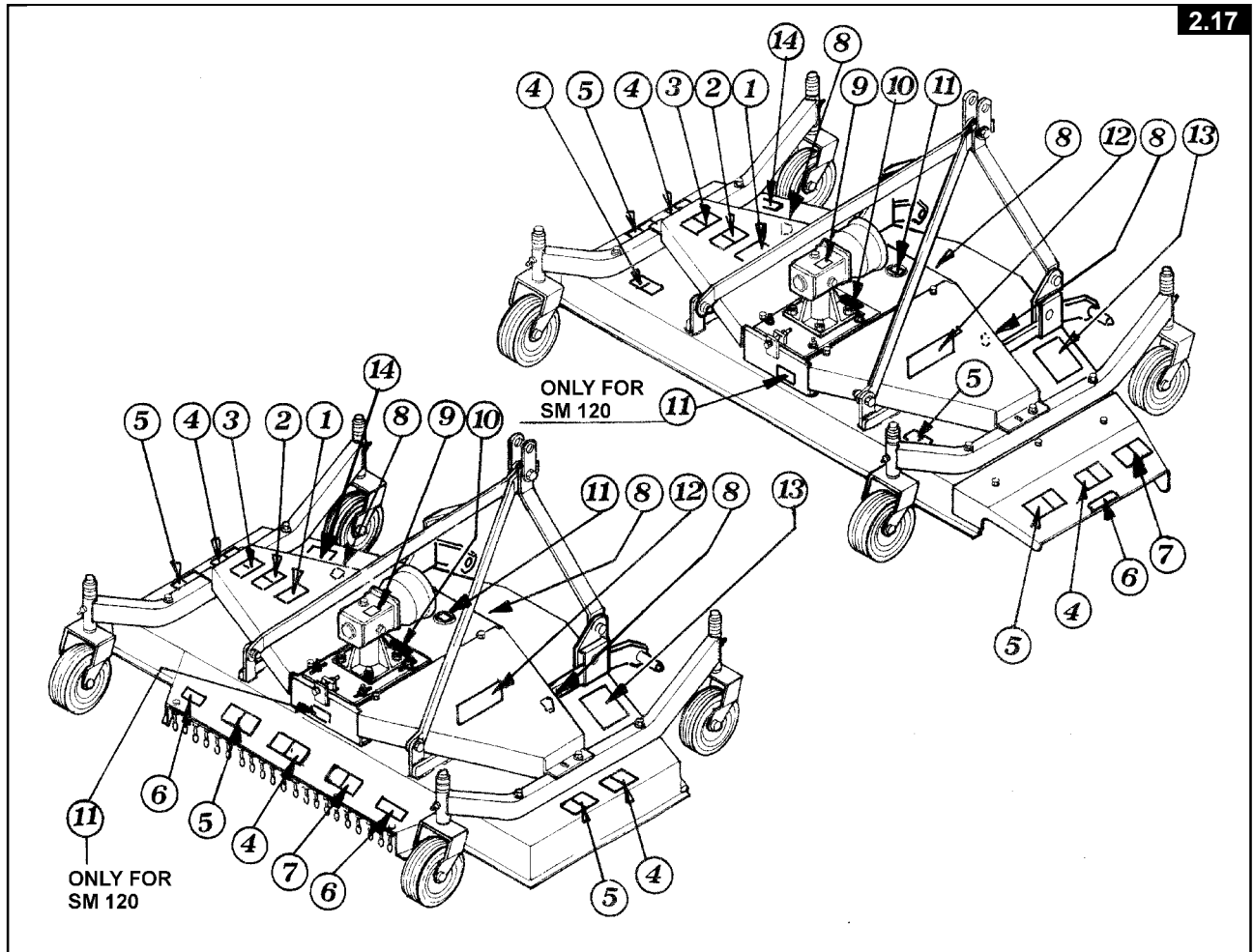

- 1) Serial number plate
- 2) See point 1 page 5
- 3) See point 2 page 5
- 4) See point 11 page 7
- 5) See point 12 page 7
- 6) See point 7 page 6
- 7) See point 10 page 7
- 8) See point 15 page 8
- 9) See point 14 page 8
- 10) See point 5 page 6
- 11) See point 16 page 8
- 12) Manufacturer decal
- 13) See point 4 page 6
- 14) Decal with model of machine

## CHAPTER 3

### GENERAL SUMMARY OF SAFETY AND ACCIDENT - PREVENTION INSTRUCTIONS

### **3.1 GENERAL SUMMARY OF SAFETY AND ACCIDENT-PREVENTION INSTRUCTIONS**

Read all the directions carefully before using the machine. When in doubt, seek advice from the manufacturers.

The manufacturing company declines all responsibility for non-compliance with the following safety and accident-prevention instructions.

- 1-** Pay attention to the danger signs and symbols in this manual and on the machine.
- 2-** Do not touch moving parts.
- 3-** All work on the machine (including adjustments) must always be carried out with the tractor immobilized and the engine switched off.
- 4-** On no account may persons or animals be carried on the machine.
- 5-** Driving the tractor with the machine connected is absolutely forbidden to persons lacking suitable experience, or who are in poor health, or who do not have a suitable driving license.
- 6-** All accident-prevention measures recommended in this manual should be scrupulously observed.
- 7-** Connecting the machine to the tractor creates a different weight distribution on the axles and so it is essential to ensure that the tractor-machine combination is stable in all anticipated working conditions. It is therefore necessary to have exact instructions from the tractor manufacturers. If such instructions are not available, suitable tests should be conducted in safe conditions in order to assess stability.
- 8-** Once the machine is connected, it can only be controlled through a Cardan shaft complete with the required overload protection and guard secured with the appropriate small chains. Be aware of the rotational direction of the Cardan shaft.
- 9-** Before operating the tractor and machine, check that all transport and operational safety devices are complete and working.
- 10-** When driving on public roads, you should comply with the Highway Code regulations for the country concerned.
- 11-** Do not exceed the tractor axle maximum weight and the total mobile weight. Heed transport regulations.
- 12-** Before starting work, familiarize yourself with the control devices and how they work.
- 13-** Wear suitable clothes. Do not wear clothing which is loose or which could become entangled in rotating or moving parts.
- 14-** Connect the machine to a suitably powerful tractor by using an appropriate lifting unit and in accordance with instructions.
- 15-** Take maximum care when connecting and disconnecting the machine to and from the tractor.
- 16-** The machine and any road transport attachments must bear the appropriate signs and symbols and have suitable protection.
- 17-** Never leave the driving seat when the tractor is running.
- 18-** It is extremely important to appreciate that road holding, steering and braking may be significantly affected with the machine attached.
- 19-** When turning corners with the machine attached, be aware of the fact that the centrifugal force will alter due to the change in the center of gravity.
- 20-** Before engaging the power takeoff check the preset revolution speed. Do not change speed from 540 rpm to 1000 rpm.
- 21-** Under no circumstances should anybody stand near the machine or any moving parts. It is the duty of the operator to ensure that this requirement is respected.

**22-**Before leaving the tractor, lower the machine with the lifting unit, stop the engine, apply the parking brake and remove the ignition key from the instrument panel.

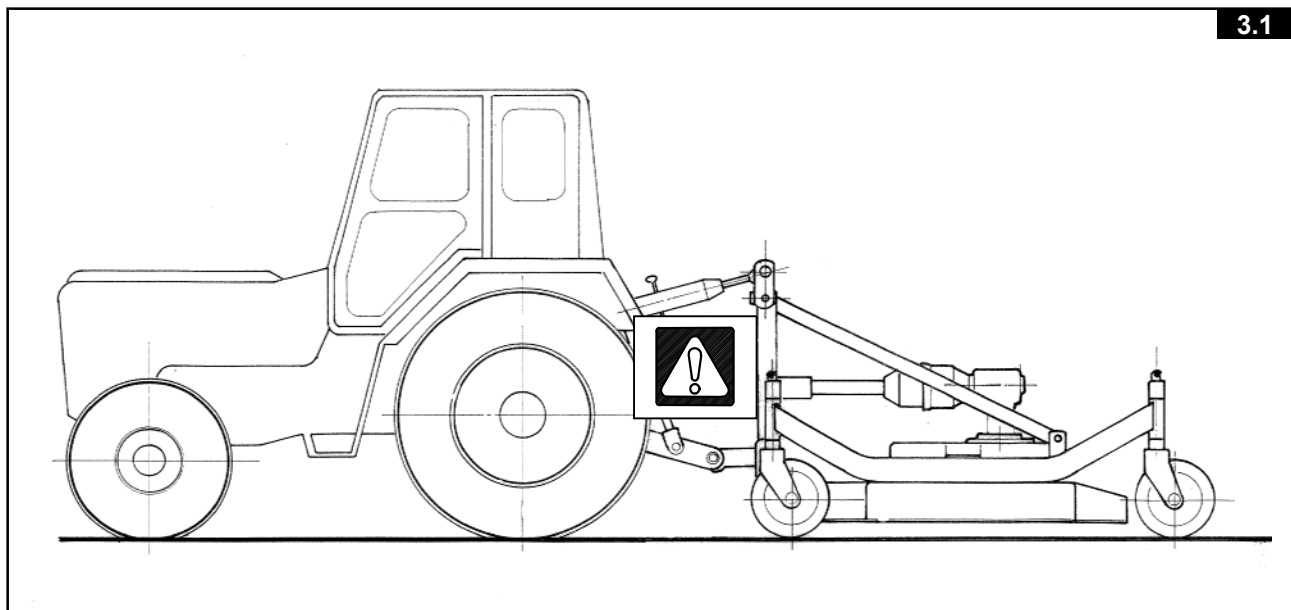

**23-**Under no circumstances should anybody go between the tractor and the machine (Fig. 3.1) when the engine is running and the Cardan shaft is engaged, especially without first having applied the parking brake and placed chocks against the wheels.

**24-**Before connecting or disconnecting the machine to or from the 3-point linkage, put the lifting unit lever into the locked position.

**25-**The connection pins on the machine must match the connection sockets on the lifting unit.

**26-**During transport, secure the lateral lifting arms with the appropriate chains and tighteners.

**27-**When the machine is raised during road transport, put the tractor's hydraulic lifter lever into the locked position.

**28-**Only use the Cardan shaft provided by the manufacturer and, in case of replacement, substitute it with one having the same characteristics.

**29-**Regularly check all protection on the Cardan shaft. This should always be in excellent condition and securely fixed.

**30-**It is important to ensure that the protection on the Cardan shaft is complete.

**31-**Connection and disconnection of the Cardan shaft must be carried out with the engine switched off.

**32-**Pay particular attention to the correct connection and safety of the Cardan shaft and the power takeoffs on the machine and the tractor.

**33-**Prevent the cardan shaft protection from rotating using the chains supplied.

**34-**Before engaging the power takeoff, make sure that there are no people or animals in the vicinity and that the selected engine speed corresponds to that permitted. Never go above the maximum permitted.

**35-**Do not engage the power takeoff when the engine is not running.

**36-**Always disengage the power takeoff when the Cardan shaft is at too wide an angle (it should never be more than 35° Fig. 3.2) and when it is not in use.

**37-**Only clean and grease the Cardan shaft when the power takeoff is disengaged, the engine is off, the parking brake is applied and the ignition key is removed.

- 38-**On disconnecting the Cardan shaft, replace the protective hood on the power takeoff shaft.
- 39-**Prolonged use of the machine can cause the drive boxes to become hot. To avoid any risk of getting burnt, avoid touching these areas both during use and some time afterwards.
- 40-**Periodically check screws and nuts for tightness and grip. Tighten if necessary.
- 41-**When carrying out maintenance work or replacing the blades, raise the machine and rest on adequate supports.
- 42-**Use the quantities of grease and oil advised.
- 43-**Spare parts must meet the requirements as defined by the manufacturer. Use only original spare parts.
- 44-**Safety decals must always be clearly visible. They must be kept clean and replaced if they become too illegible (they can be ordered from the agent if necessary).
- 45-**The instruction booklet must be available for the lifetime of the machine.

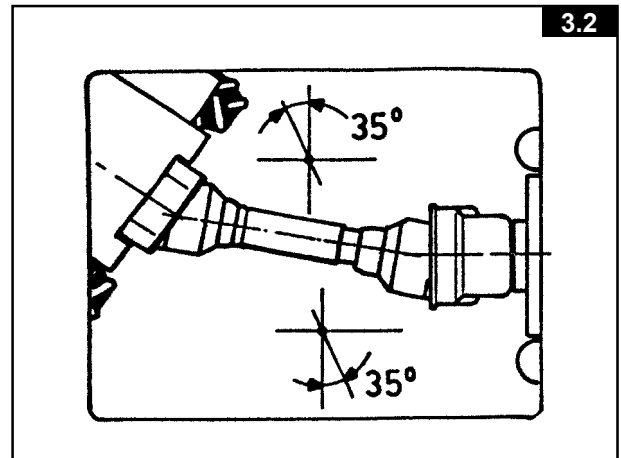

## CHAPTER 4

### PRODUCT IDENTIFICATION



### 4.1 TECHNICAL DATA

Model	RPM of gearbox	Blade RPM	Blade tip speed m/s	No. Blades	Cutting height		Power required HP/kW
					mm	inches	
SM/120	540*	3250	70.1	3	20 - 100	3/4" - 4"	20/15
SM/150	540*	2630	70.5	3	20 - 100	3/4" - 4"	30/22
SM/180	540*	2230	70.5	3	20 - 100	3/4" - 4"	40/30

\* Standard supply (gearboxes with P. T. O. shaft of 1000 r. p. m. and 2000 r. p. m. are supplied on request). The manufacturer reserves the right to alter the technical data without notification.

### 4.2 MAIN MACHINE PARTS

ITEM	Description	ITEM	Description
1	Machine casing	9	3-point hitch
2	Gearbox support	10	Axles
3	Gearbox	11	Wheel unit
4	Protective cap	12	Pin lever
5	Protective guard	13	Cardan shaft
6	Protective chain	14	Name plate
7	Tie rod	15	Side ejector piece
8	Front bracket		

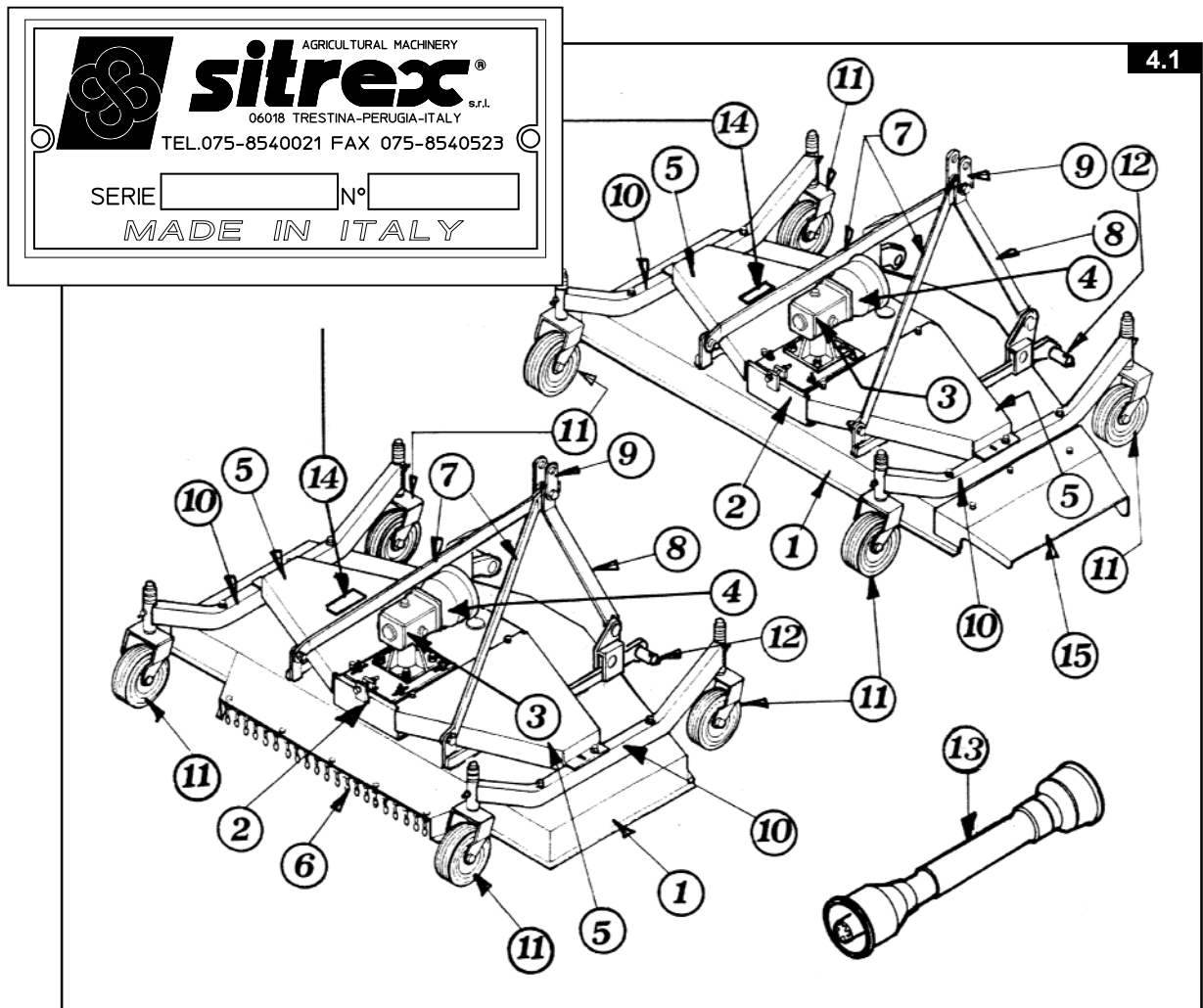

## CHAPTER 5

### DELIVERY AND ASSEMBLY

## 5.1 CHECKING THE MACHINE ON DELIVERY



All parts carefully checked before dispatch or delivery.

On receiving the machine, ensure that it not been damaged during transport. If damage has occurred, contact the dealer concerned.

How the machine is lifted will depend on the model and the type of packing. Details are given below. The packing can vary from country to country depending on transport requirements.



Lift the machine using a forklift truck, crane or other suitable equipment of sufficient capacity after first checking the weight of the configurations in the table given below.

Check the stability and positioning of the load on the forklift truck forks or crane hook.

Keep the load as low as possible during movement for maximum stability and to ensure that the operator has maximum visibility.

If a forklift truck is used, ensure that the forks are positioned as wide apart as possible.

The manufacturer packages the machines according to the following models:

Fig. 5.1: represents the standard packaging for the lawn mower with rear grass ejector.

Fig. 5.2: represents the standard packaging for the lawn mower with side grass ejector.

Fig. 5.3: represents the packaging for both the lawn mower with rear grass ejector and lawn mower with side grass ejector.

Fig. 5.4: represents the packaging for both machine types using nylon film (in this case a varying number of machines may be packed together, depending on the quantity ordered by the client and the space available on the transport means).

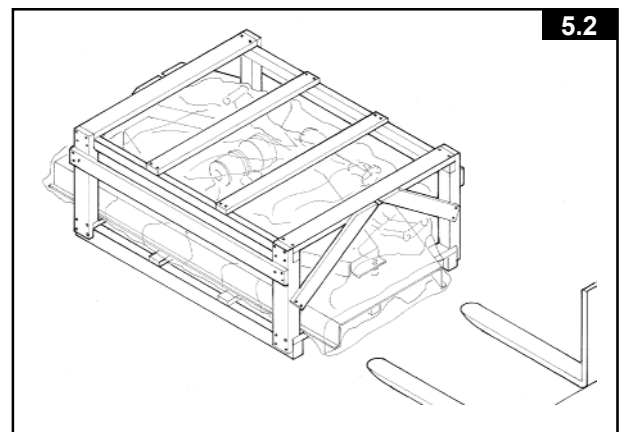
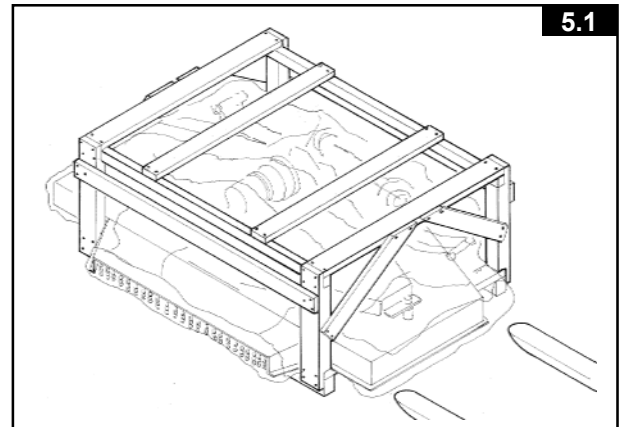

PACKAGING TYPE	MACHINE WEIGHT KG-LBS					
	120 Rear	120 Side	150 Rear	150 Side	180 Rear	180 Side
Fig. 5.1 *	178-390	--	208-455	--	239-525	--
Fig. 5.2 *	--	168-370	--	202-445	--	227-500
Fig. 5.2 *	200-440	186-410	229-505	221-485	266-585	256-565
Fig. 5.4 **	173-380	164 -360	202-445	194-425	231-475	221 -485

\* Weight of crated machine  
 \*\* Net weight of one machine each model



**Notes:**

- 1) Slightly different packaging from those represented may occasionally be used, depending on the methods of transport or handling.
- 2) The packing consists mainly of wood, which should be disposed of according to the laws in force in the country where the machine is used. The plastic film should also be disposed of according to the laws in force in the country where the machine is used.
- 3) When storing, it is permissible to stack 2-3 crates on top of each other. Make sure that they are perfectly aligned vertically.
- 4) In the case of further transportation, make sure the machine is well secure on the transport means.

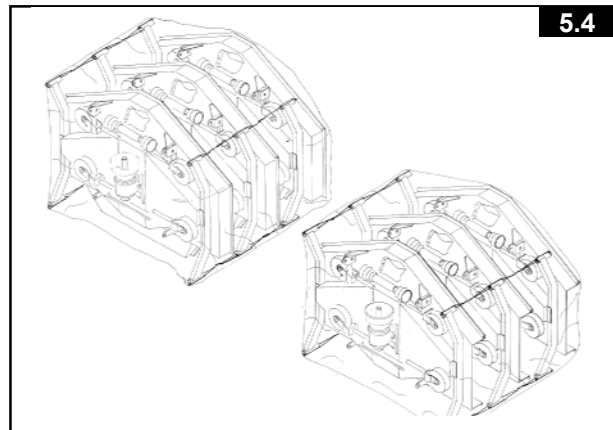
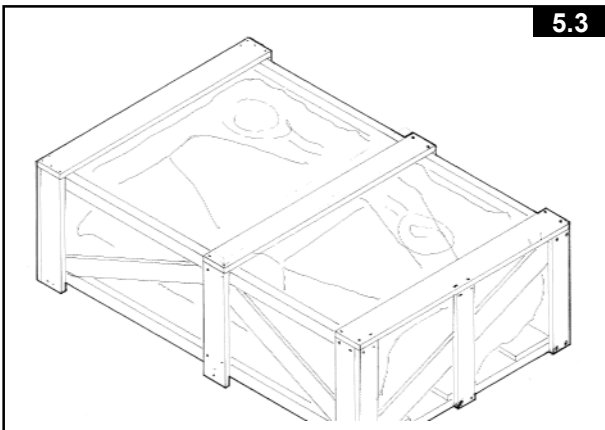

The unpacked machine is composed of the following parts:

Machine with rear grass ejector			Machine with side grass ejector		
ITEM	Description	Q.ty	ITEM	Description	Q.ty
1)	Machine casing	1	1)	Machine casing	1
2)	Wheel axle	2	2)	Wheel axle	2
3)	Wheel unit	4	3)	Wheel unit	4
4)	Front bracket	1	4)	Front bracket	1
5)	Tie rod	2	5)	Tie rod	2
6)	Protective cap	1	6)	Protective cap	1
7)	Cardan shaft	1	7)	Cardan shaft	1
8)	Bag of nuts and bolts	1	8)	Bag of nuts and bolts	1
9)	Bag of accessories	1	9)	Bag of accessories	1
			10)	Side ejector piece	1

**N.B.** In the packaging type on Fig. 5.4, the axles 2 are already attached to the main casing 1.

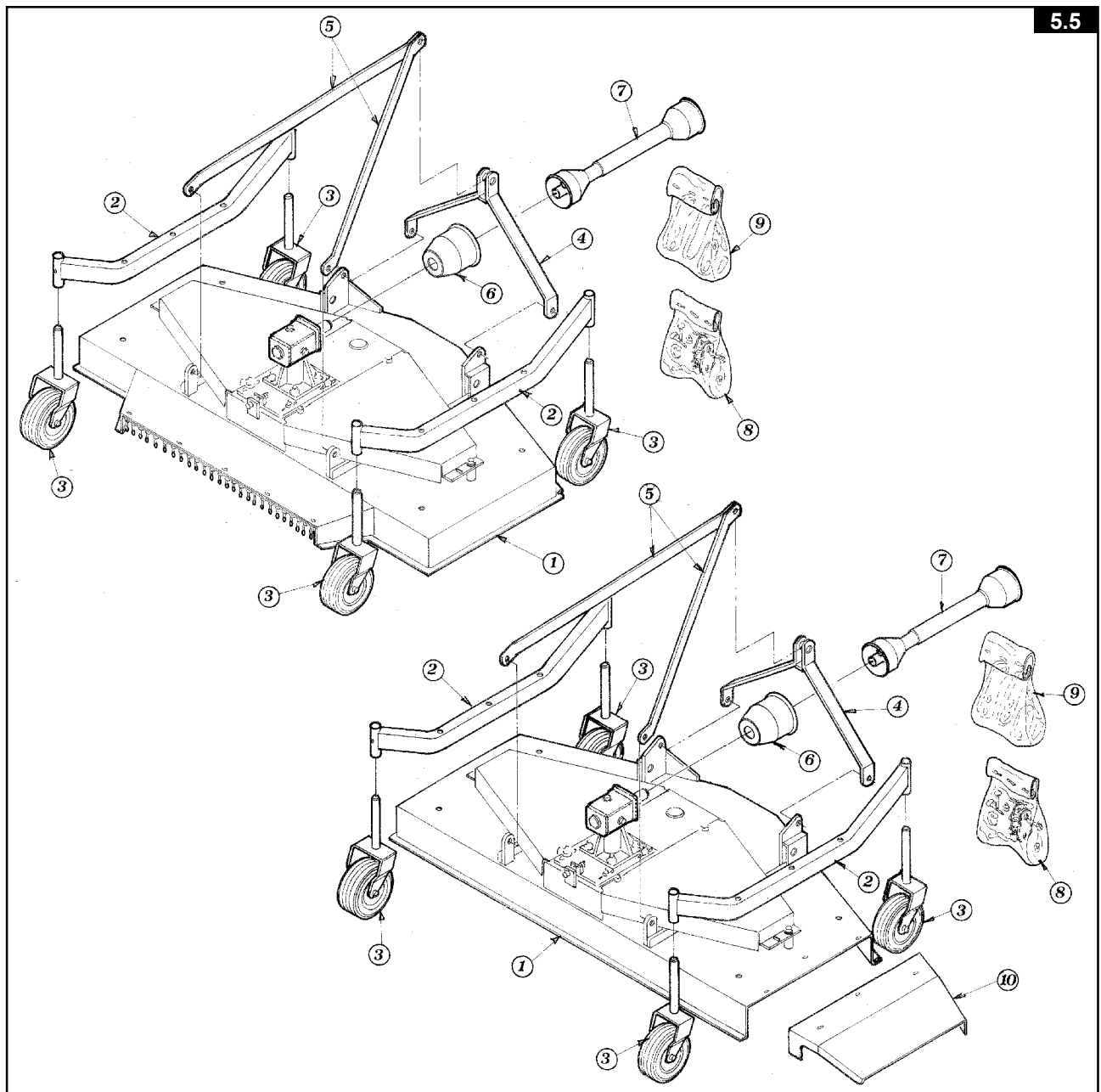

The contents of item 8 (bag) are as follows:

<b>Machine with rear grass ejector</b>		<b>Machine with side grass ejector</b>	
<b>Description</b>	<b>Q.ty</b>	<b>Description</b>	<b>Q.ty</b>
Shim D 25/35 x 2	4	Shim D 25/35 x 2	4
Shim D 25/35 x 6	4	Shim D 25/35 x 6	4
Shim D 25/35 x 12	4	Shim D 25/35 x 12	4
Shim D 25/35 x 25	4	Shim D 25/35 x 25	4
Shim D 25/35 x 32	4	Shim D 25/35 x 32	4
Screw M12x35	4	Screw M12x35	4
Screw M12x90	1	Screw M12x90	1
Screw M10x80	4	Screw M10x80	4
Screw M8x16	2	Screw M8x20	3
Self-locking nut M12	5	Screw M8x16	2
Flat washer D 10.5	4	Self-locking nut M12	5
Flat washer D 8.5	2	Nut M8	3
Notched washer D 10.5	4	Flat washer D 10.5	4
Grease nipple M6	4	Flat washer D 8.5	5
Split pin BS 8	4	Notched washer D 10.5	2
Split pin BC 3	2	Notched washer D 8.5	3
Pin	2	Grease nipple M6	4
3 -point bush	2	Split pin BS 8	4
Pin D 19	2	Split pin BC 3	2
		Pin	2
		3 -point bush	2
		Pin D 19	2

Bag item 9 is the same for both machine types and contains:

3-point hitch      Q.ty 1  
Lower hitch        Q.ty 2

## 5.2 ASSEMBLY SEQUENCE



Assembly is highly dangerous and must be carried out in strict accordance with the following instructions. We recommend that qualified personnel perform assembly. We also recommend that assembly be carried out in a flat, open area with no people (particularly children) nearby who could be severely injured if they were to touch or move any parts of the machine.

### 5.2.1

Keep the main casing 1 approx. 300/500 mm above the ground, resting it on suitable supports or on the forks of a forklift.

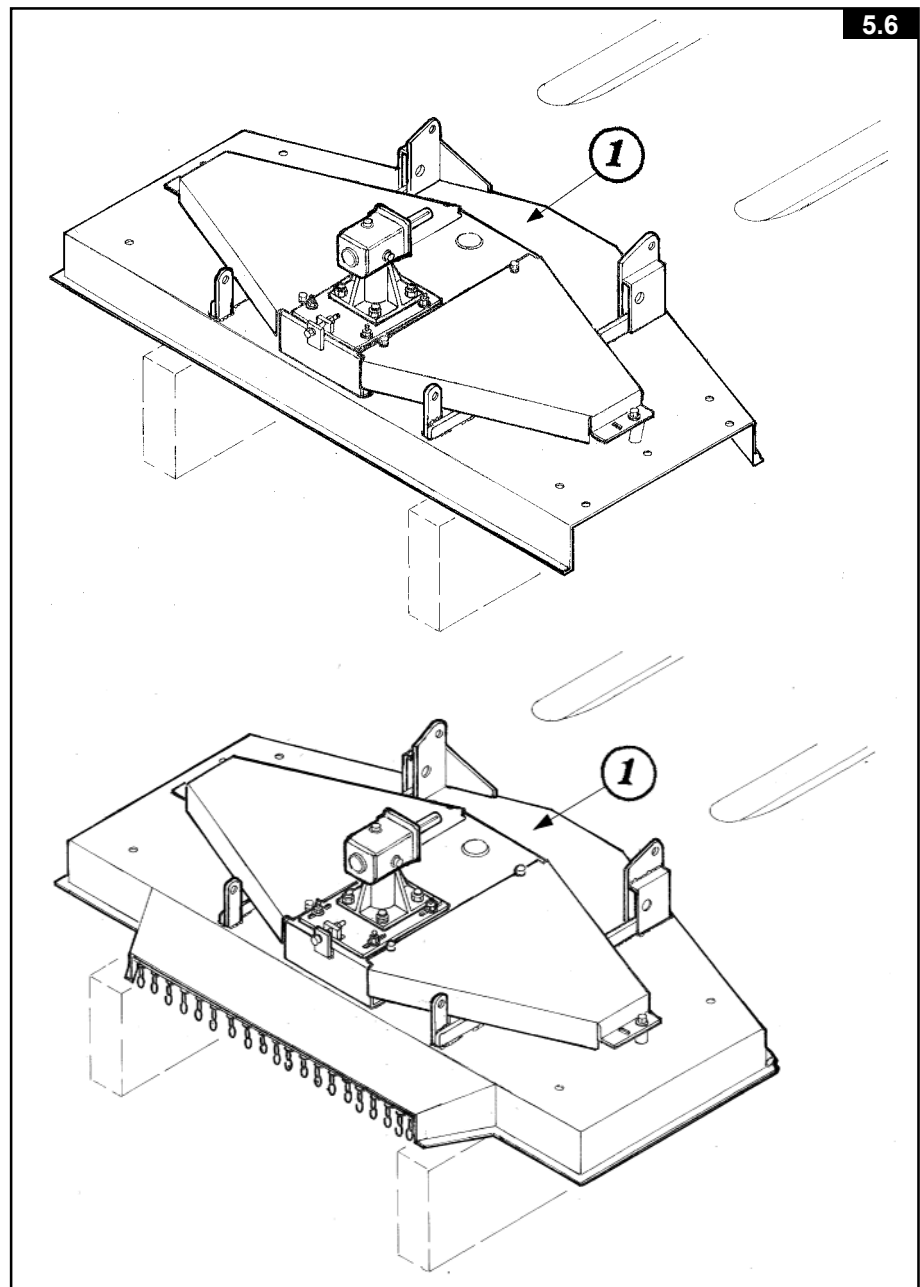

**5.2.2**

Fit the protective cap 2 to the correct mounting on the gearbox 1 using the flat washers 3 and the screws 4.

For this step you will use:

Item 2: n° 2 - flat washers D 8.5 (D 21/64)

Item 3: n° 2- screws M8x16 (5/16x5/8)

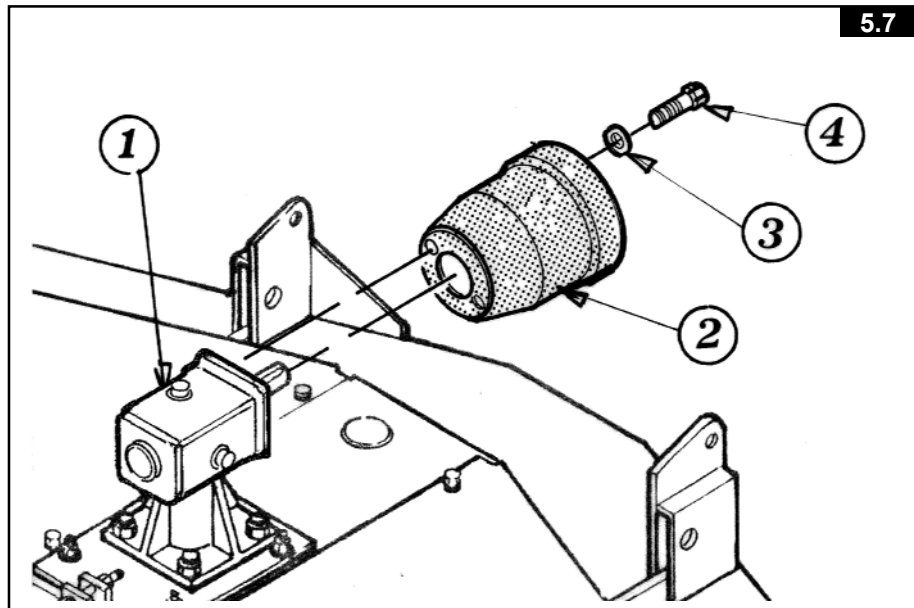

**5.2.3**



Fit the axles 2 to the main casing 1. To do this you must initially remove the central screws 6 and the washers 4 & 5, which attach the protective, guard 3 to the main casing 1. Then fix the axles 2 to their correct mountings on the main casing 1 using the flat washers 4, the notched washers 5 and the screws 6. For this step you will use:

Item 4: n° 6 - flat washers D 10.5 (D 27/64)

Item 5: n° 6 - notched washers D 10.5 (27/64)

Item 6: n° 6 - screws M10x80 (D 25/64x3"3/16)

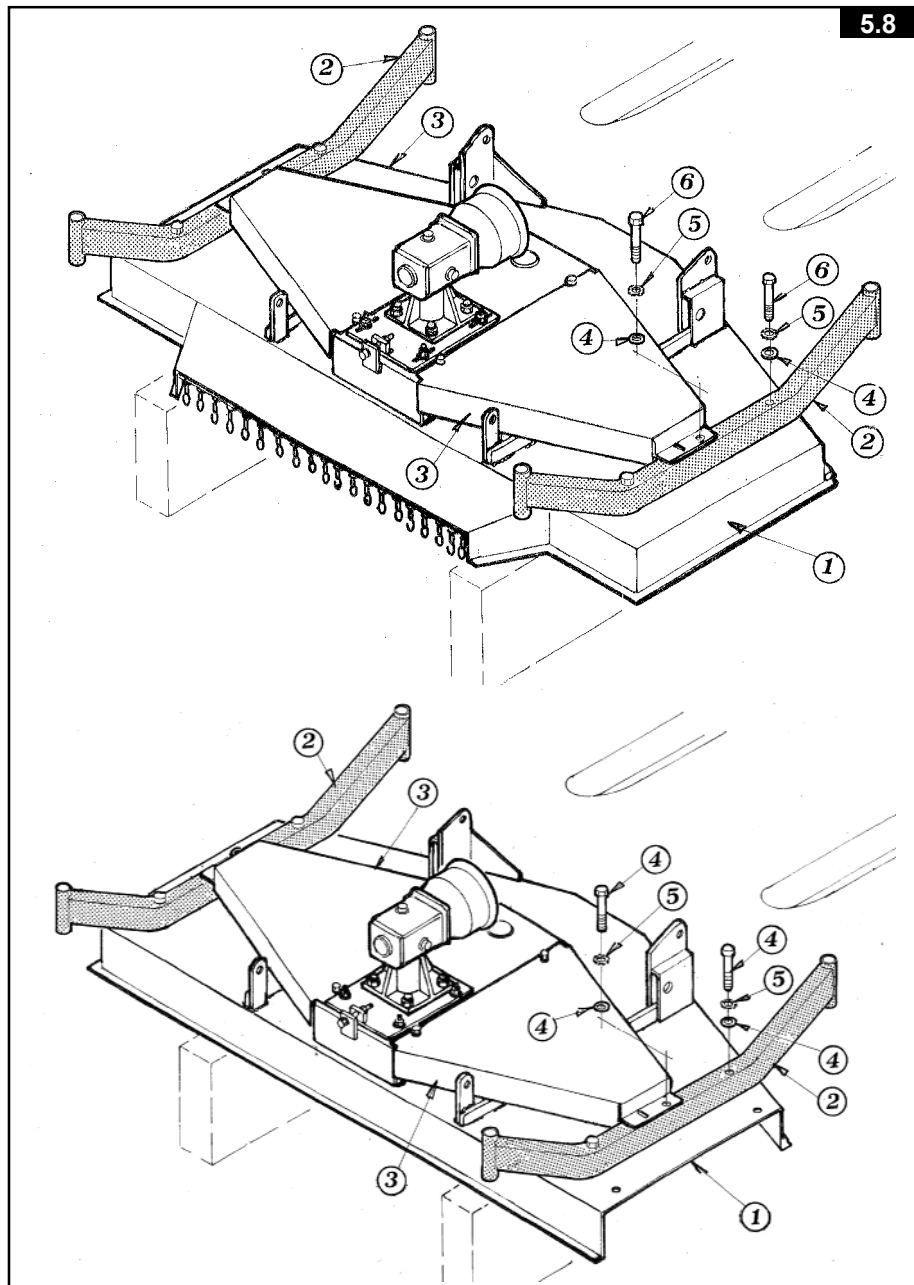



## 5.2.4



Fit the wheel units 2 to their correct mountings on the axles 1. Connect the shim 3 (D 25/35x12 - D 1"x1"3/8x1/2") to the axle on wheel unit 2. The shim is selected according to the required cutting height (see page 36), therefore what we are describing is an example.

Next, the wheel unit 2, onto which the shim 3 has been secured, must be connected to the correct seat on the axles 1. Now fasten onto the axle of the wheel unit 2 the shims:

item 4 (D 25/35x32 - D 1"x1"3/8x1"1/4)

item 5 (D 25/35x25 - D 1"x1"3/8x1")

item 6 (D 25/35x6 - D 1"x1"3/8x1/4)

item 7 (D 25/35x2 - D 1"x1"3/8x5/64).

At this stage secure everything with the split pins 8. Fit the grease nipples 9 to the correct positions on the axles 1.

For this step you will use:

Item 8: n° 4 - split pins  
D 8 (5/16)

Item 9: n° 4 - grease nipples  
M6 (15/64)

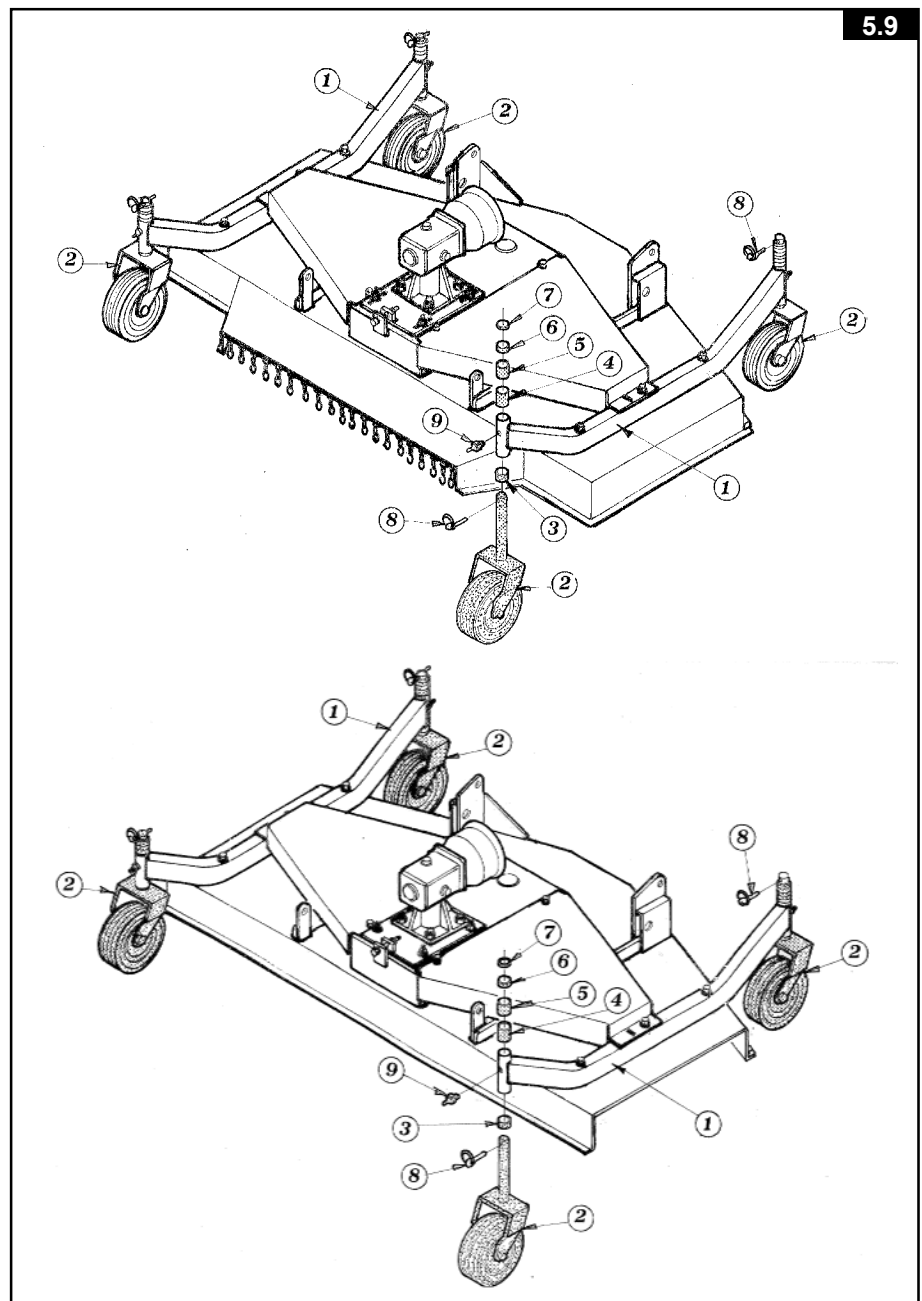

## 5.2.5



Fix the front bracket 2 to the correct mountings on the main casing 1 using the screws 3 and the nuts 4. Do not tighten the nuts 4. For this step you will use:

Item 3: n° 2 - screws M12x35 (15/32x1"3/8)

Item 4: n° 2 - nuts M12 (15/32)

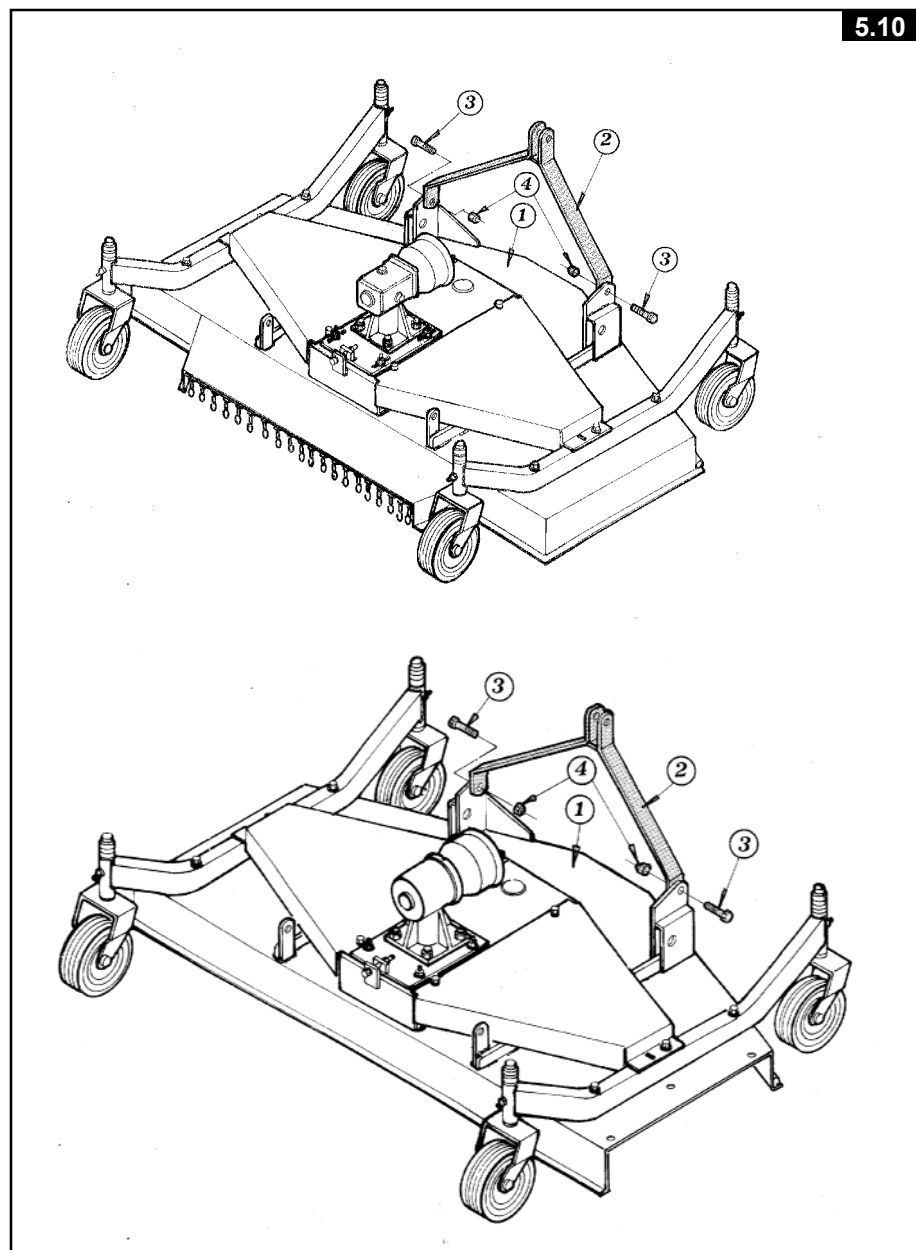

## 5.2.6



Fit the tie rods 3 to the correct seats of the main casing 1 and the front bracket 2 using the screws 4 and the nuts 5. Do not fully tighten nuts 5.  
For this step you will use:

Item 4: n° 2 - screws M12x35 (15/32x1"3/8)

Item 5: n° 2 - nuts M12 (15/32)

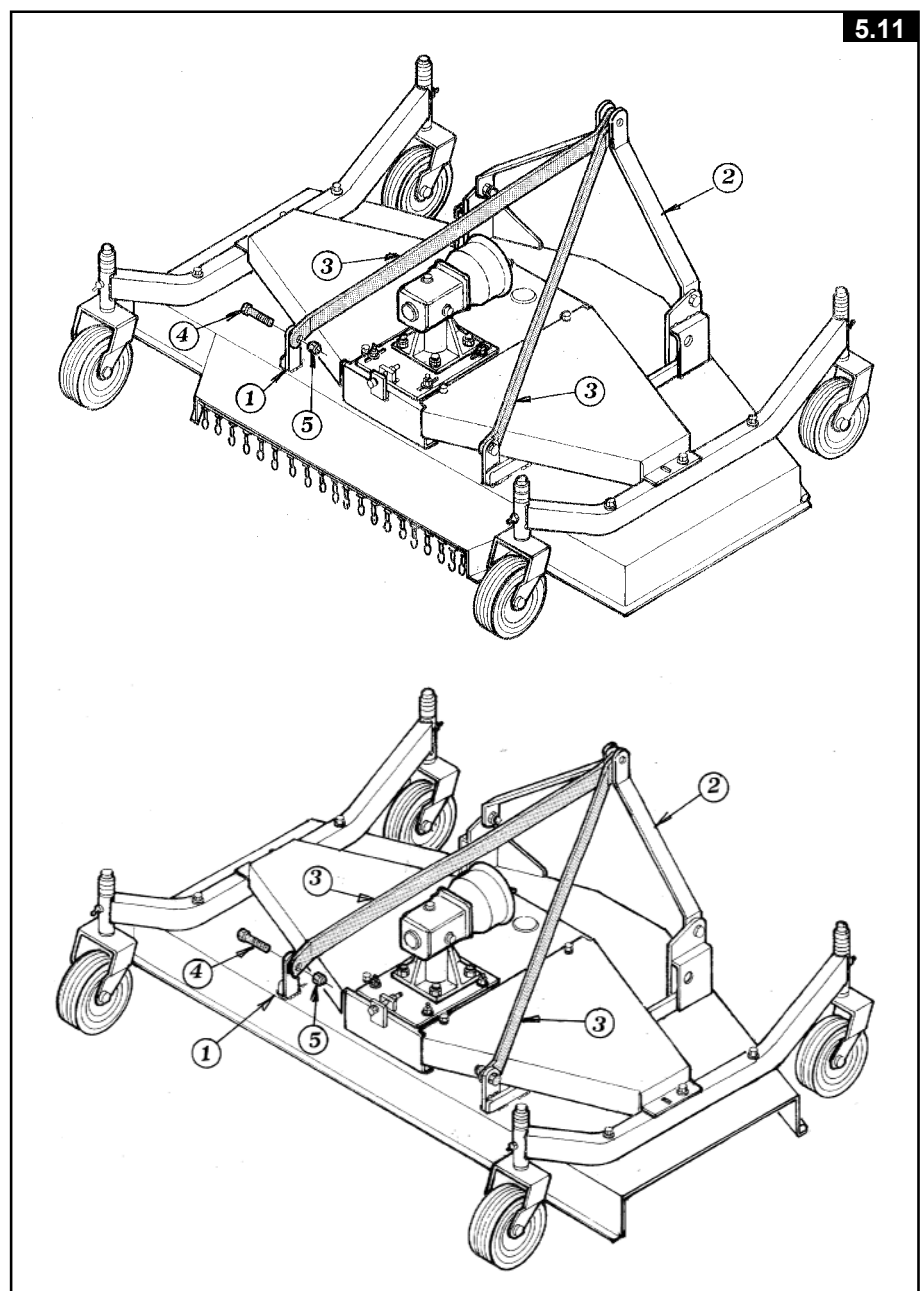

## 5.2.7



First fix the bushes 4 onto the 3-point hitch 1. The lug of the bush must be positioned on the inside of the 3-point hitch 1. The 3-point hitch 1 with secured bushes 4 must be fixed to the front bracket 2 and tie rods 3 using screw 5 and nut 6. Now fully tighten the nuts in points (A) and (B). For this step you will need:

Item 5: n° 1 - screw M12x90 (15/32x3"3/4)

Item 6: n° 1 - nut M12 (15/32)

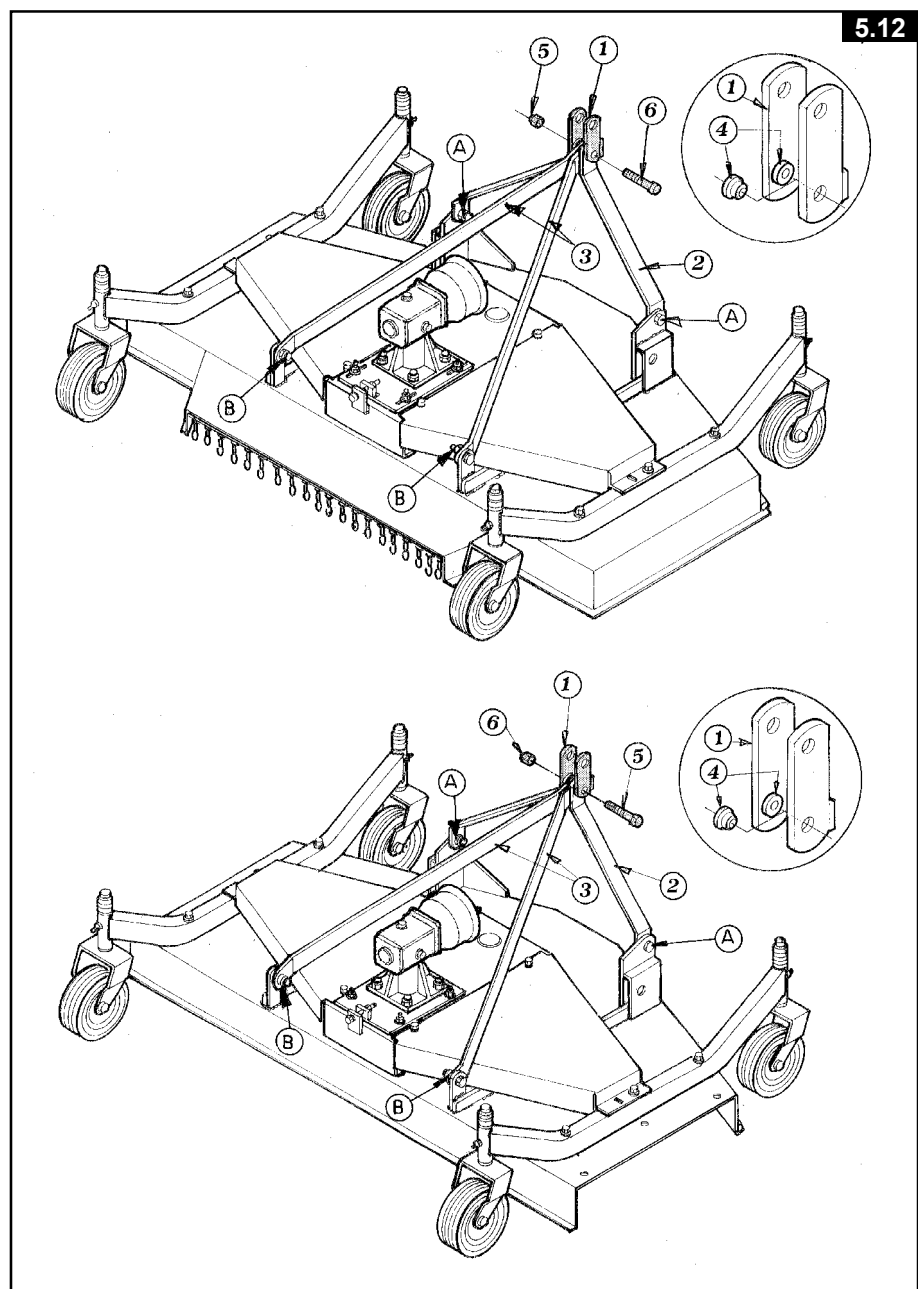

### 5.2.8 Only for machines with side grass ejector

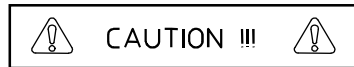

Attach the side ejector piece 2 to the main casing 1 using the screws 3, the flat washers 4, the notched washers 5 and the nuts 6. For this step you will need:

Item 3: n° 3- screws M8x20 (5/16x3/4)

Item 4: n° 3 - flat washers D 8.5 (D 21/64)

Item 5: n° 3- notched washers D 8.5 (D 21/64)

Item 6: 3 nuts M8 (5/16)

### 5.2.9



Fit the lever 2 to the correct seat on the main casing 1 and secure it with the pin 3 and split pin 4. Fix pin 5 on to the lever 2 and lock it with the Grover washer 6 and the nut 7.

**N. B. There are two holes at one end of lever 2 in order to attach it to the machine. To choose which holes should be used, see page 37**

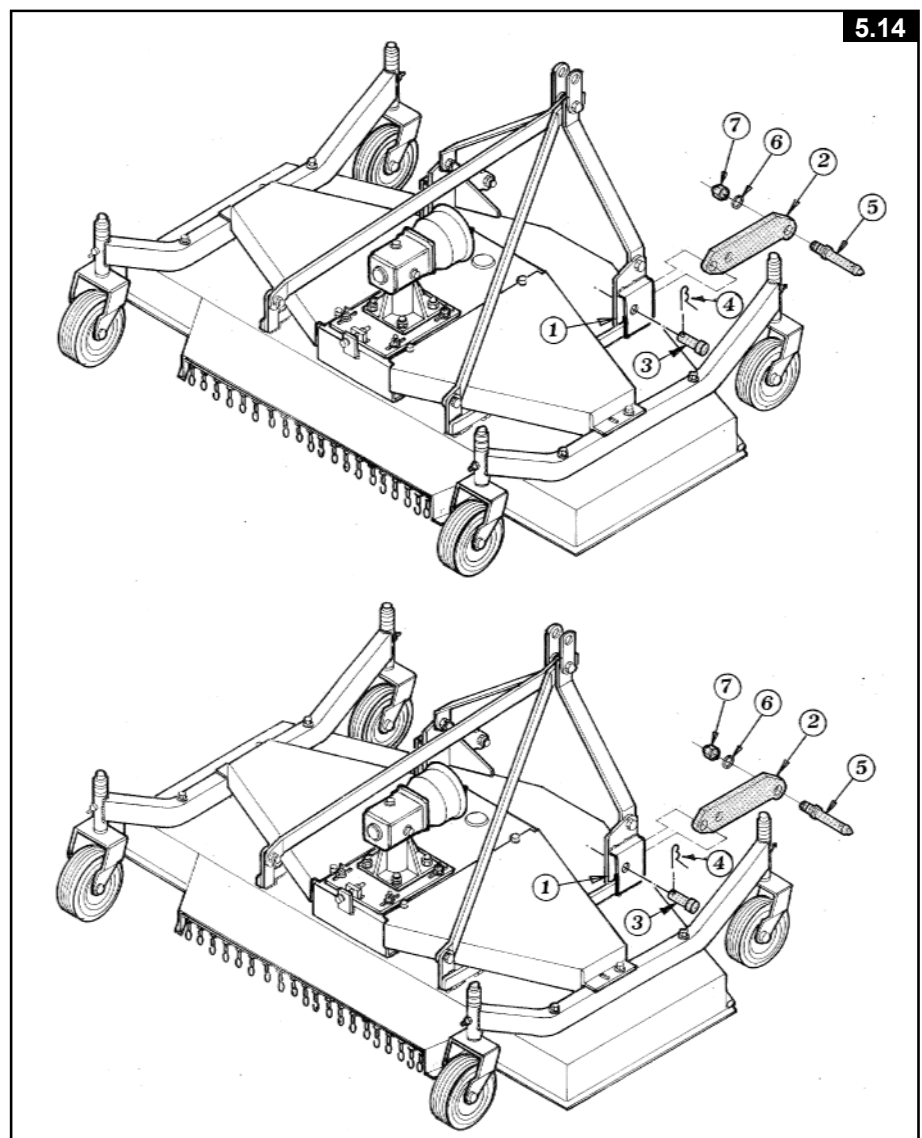
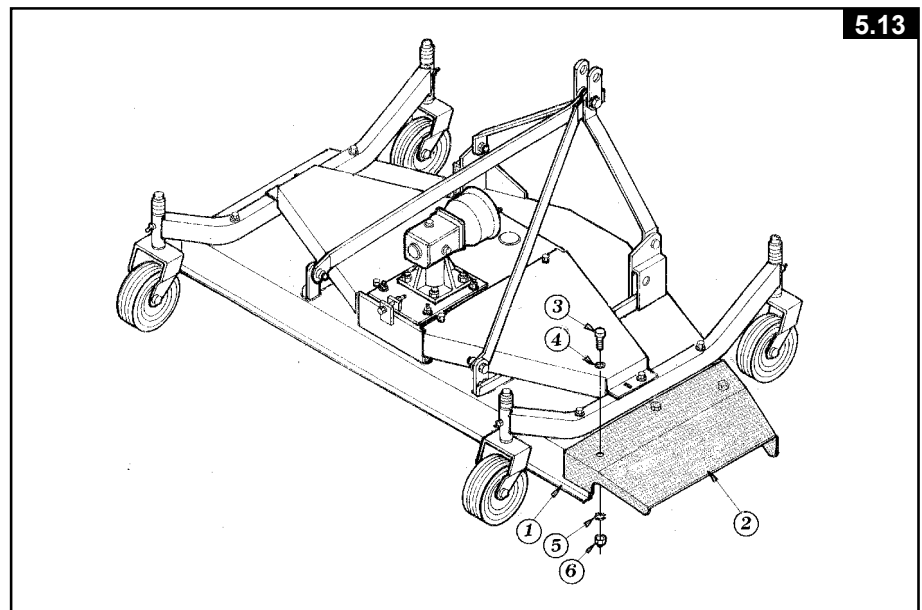

5.2.10

Now the machine is completely assembled and ready for use.

5.15

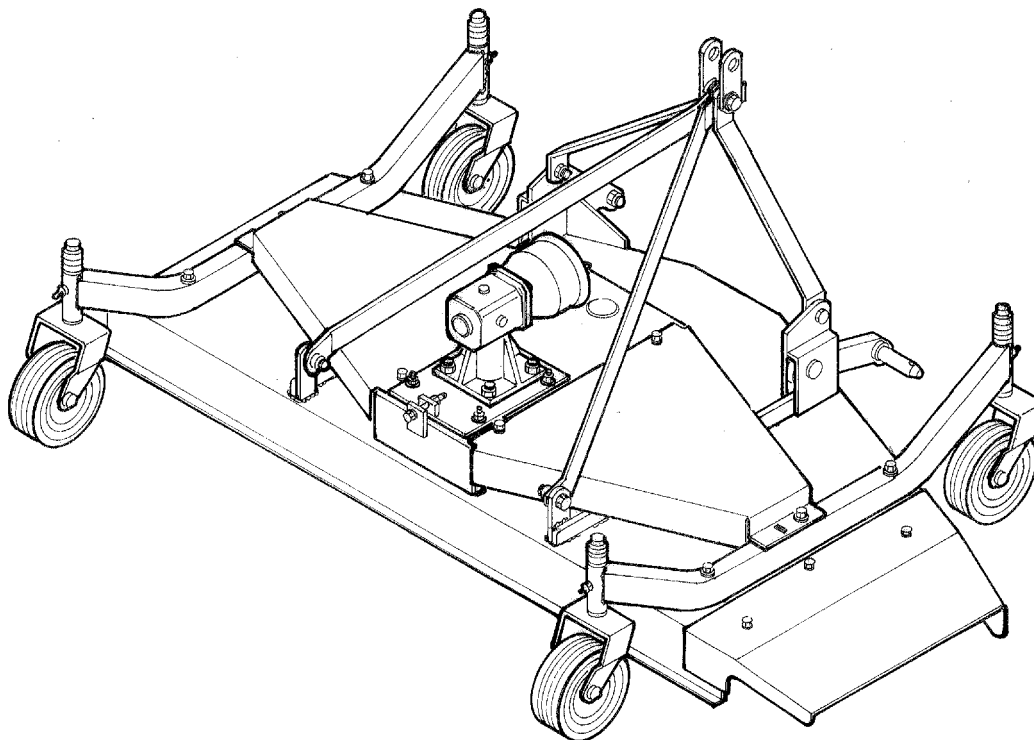
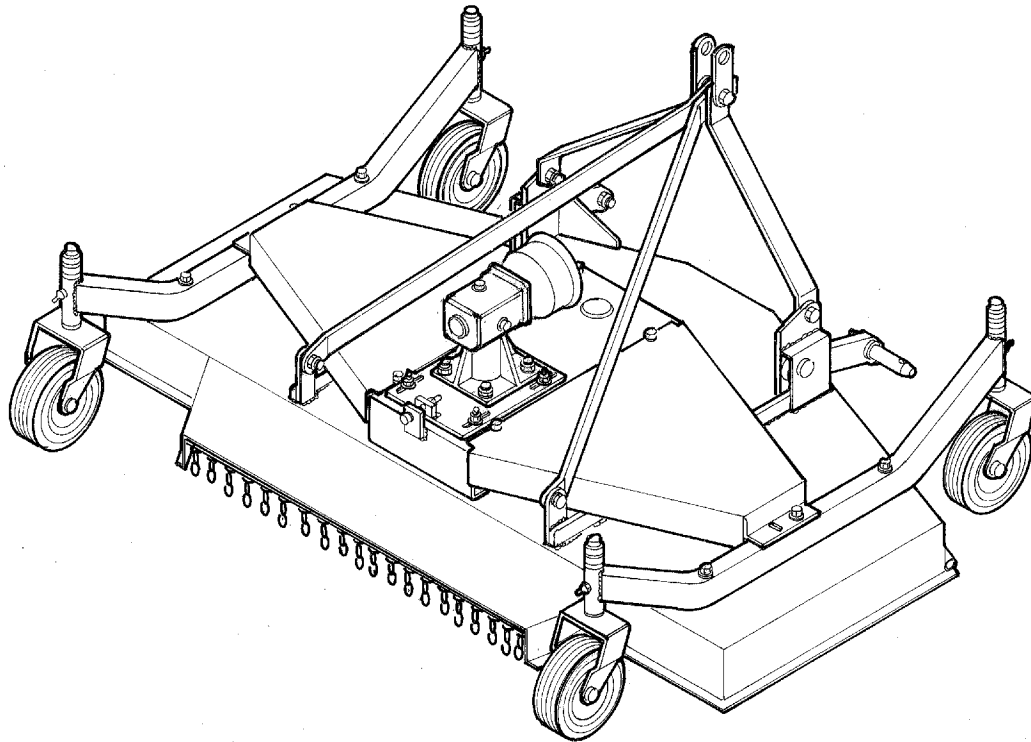

## 5.3 SPECIAL MODELS

Lawn mowers that can be attached to the front of tractors are also available. They are used and maintained in the same way as the other models. We will briefly illustrate where it is necessary to follow a slightly different procedure.

### 5.3.1 ASSEMBLY



The front bracket 1 should be attached to brackets "A" in the same way as the standard models. The tie rods 2 should be attached to brackets "B" and to the correct mounting on the front bracket 1, again using the same procedure as in the standard models. The 3-point hitch 3 should also be fitted in the same way. See point 5.2.1-5.2.10 page 21-27

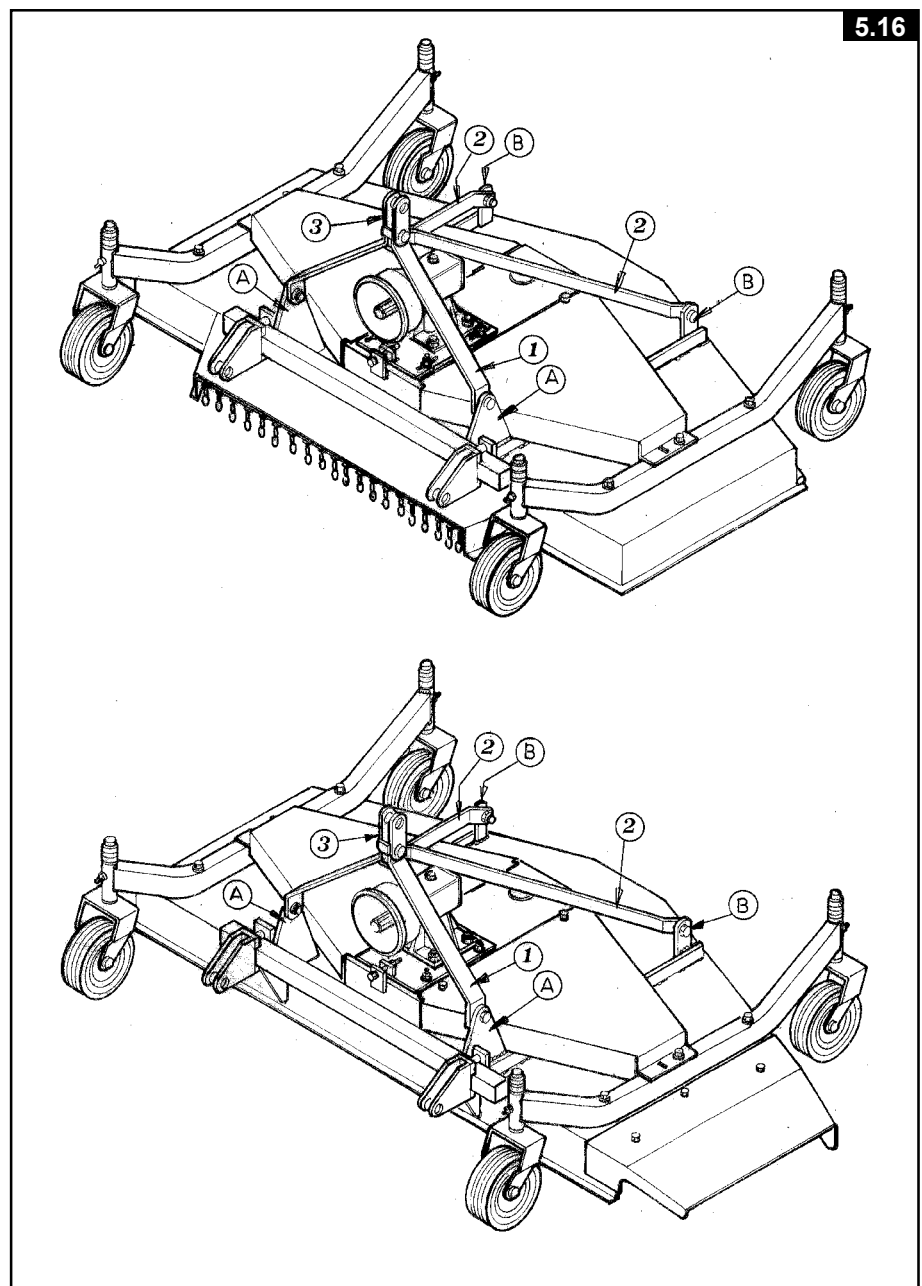

### 5.3.2 MOUNTING TO THE TRACTOR

All the instructions for the standard models are valid. Bear in mind that hooking the machine up to the tractor is not an easy task, as the tractor could obstruct one from getting close enough to the machine. In order to do this you must attach the tractor's transport arms 1 to the brackets 3 using the pins 4 and split pins 5. Then attach the tractor's 3-point hitch 2 to the machine's 3-point hitch 6.

**N.B.-** The brackets 3 can be shifted by adjusting the screws, which secure them to the frame of the machine, so as to accommodate the tractor's transport arms 1.

These machines are supplied with 1000 or 2000 r. p. m. gearboxes and with clockwise or anticlockwise direction of rotation. Make sure that the machine is compatible with the tractor.

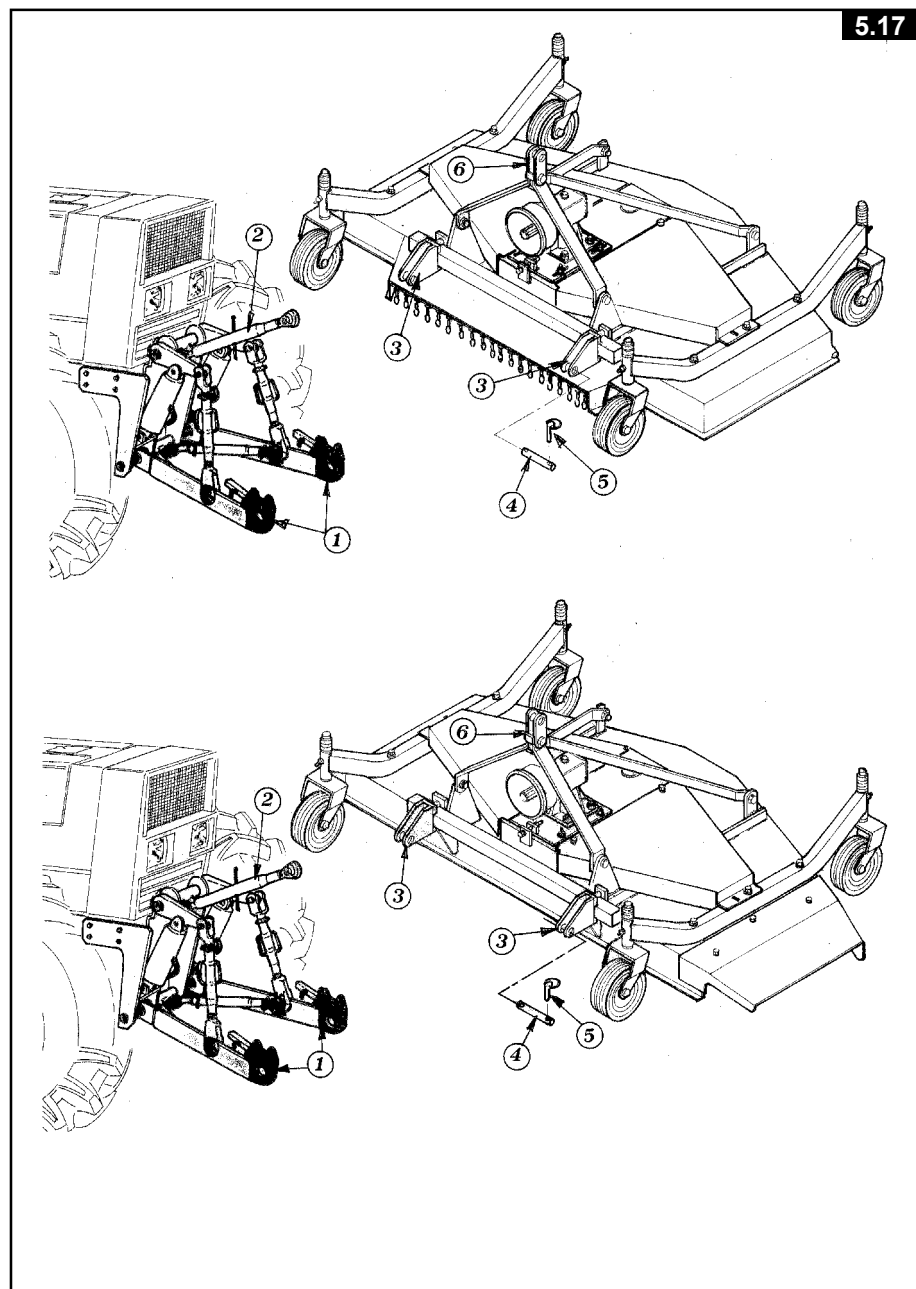



## CHAPTER 6

## ADJUSTMENT, PREPARATION AND USE

## 6.1 INTRODUCTION



- 1) Connection to the tractor is highly dangerous. Take great care and carry out the entire operation in strict compliance with the following instructions.
- 2) Nobody should go near the area between the tractor and the machine.
- 3) Check that all warning and danger signs are in place and legible.
- 4) Check that the tractor is in good running order.
- 5) Check the engine oil, gearbox oil, brake fluid and cooling water levels as well as the tire pressures.
- 6) Refer to the tractor operator's manual.

## 6.2 MOUNTING TO THE TRACTOR



Bring the tractor close in reverse and check that the transport arms of the tractor 1 are aligned with the pins 2. Turn off the tractor, apply the parking brake and remove the key from the ignition.

Fit the joints at the tips of the arms 1 on to the pins 2 and secure them with the split pins 3.

Connect the tractor's 3-point hitch 4 to the machine's 3-point hitch 5 using pin 6 and split pin 7. Adjust the tie rods 8 so that lateral oscillation of the machine is limited: it is advisable to maintain a lateral oscillation of about 50 mm (2").

By adjusting the arms 9, level the machine with the ground.

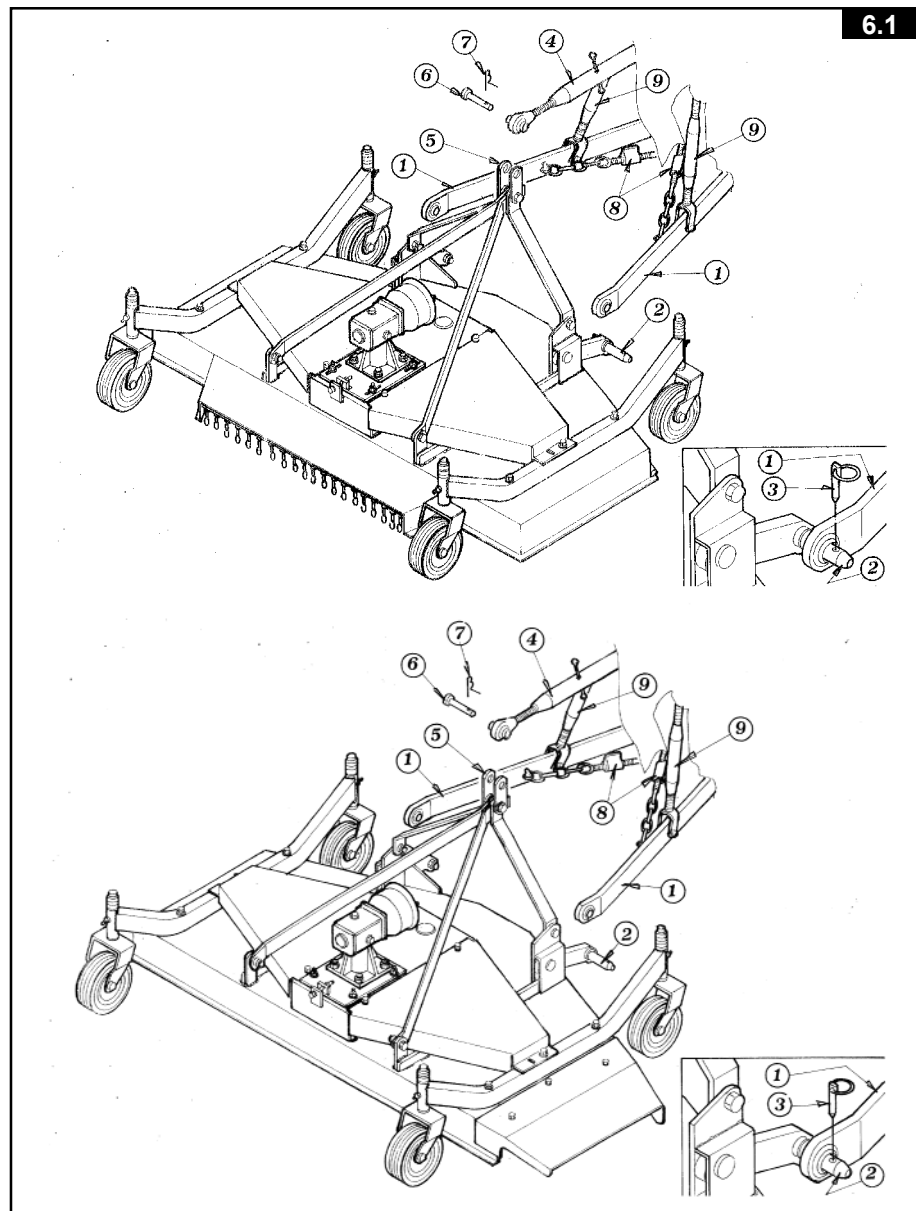

### 6.3 CONNECTING THE CARDAN SHAFT



More detailed information may be found in the Cardan shaft manual which, together with this manual, is an essential part of the accident-prevention documentation.

It is your responsibility to read and comply with this documentation. If information given in this manual should conflict with that given in the Cardan shaft manual, you should follow the instructions given by the Cardan shaft manufacturer.



Fit the Cardan shaft and check that the shaft is connected correctly both at the tractor end and at the machine end. For more details, see the descriptions on the following pages.

If a safety system is provided, this should be fitted to the machine end, not to the tractor end.

During both transport and use, avoid conditions where the Cardan transmission shaft is extended to the maximum. In all working conditions, the telescopic tubes must overlap by at least 1/3 of their length (Fig.6.2).

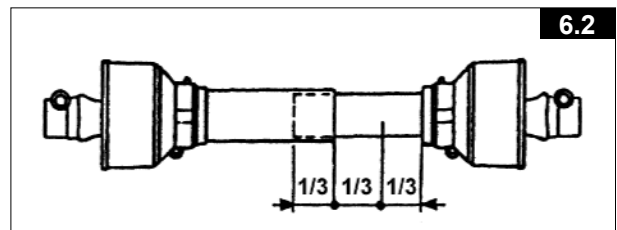

Conversely, when the Cardan shaft is contracted to the maximum, there should still be a gap of approximately 50 mm (2") (Fig.6.3).

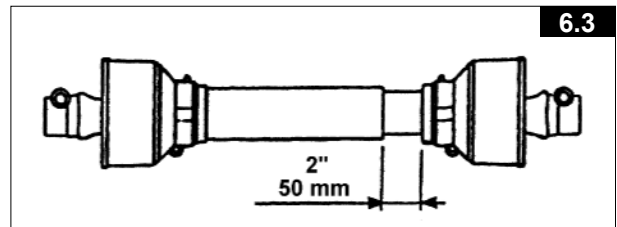

Take particular care when connecting the two Cardan shaft end forks and make sure that they are fully secured. This is achieved by inserting the safety pins and bolts (1) (Fig.6.4.) in the special slots (2) on the power takeoff shafts on both the tractor and machine ends.

A loose shaft could come apart and cause considerable mechanical damage and serious injury to persons.

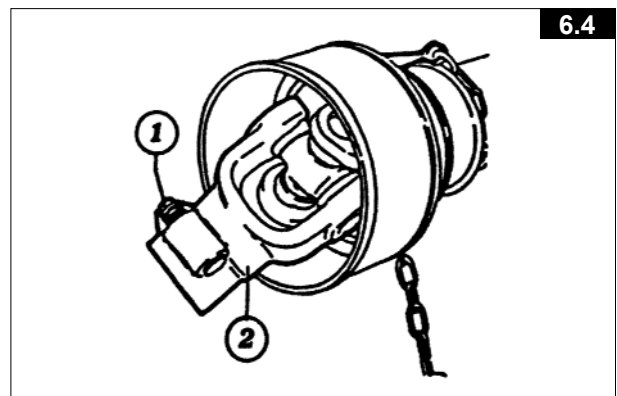



## 6.4 TRANSPORT BY ROAD

After the machine has been attached to the tractor as previously described and before transporting it to or from fields or any other workplace, the following instructions should be heeded:



Before setting off with the machine attached to the tractor, check the local road transport regulations. During transport keep the machine fully raised with the power takeoff disengaged and the lifting unit immobilized. Check that all guards, safety protection and locking split pins are in place, functioning and correctly fitted. Ensure that nobody leans against, or climbs on to, the machine during transport. The machine is an agricultural machine ***NOT designed for transporting persons or goods***. Consult the tractor maintenance and-use manual where necessary. Maintain constant control over the vehicle and ensure that you know how to stop the tractor quickly and switch off the engine.

When on a public road, observe all Highway Code regulations. Drive near the edge of the road and try not to obstruct traffic.

Do not park the tractor and/or the machine where it might obstruct, or be a danger to, any public right of way. Avoid going onto a public road if the tractor or machine is very dirty - you could leave a trail of soil, grass and other matter which could dirty the road and obstruct normal traffic.

## 6.5 GENERAL INSTRUCTIONS FOR FIELD USE

Before starting work, familiarize yourself with the following general instructions:



Before using the machine ensure that all safety precautions are taken. Check that all safety protection and guards are in place and working. Inspect the work site in order to familiarize yourself with the terrain.

Do not start the tractor before being properly seated in the driving position.

Do not start the machine if it is damaged (or even if you only suspect it is damaged) and inform your nearest dealer of the problem and ask for assistance.

Do not allow yourself to become distracted when working: give your full attention to the job in hand.

Maintain constant control over the tractor and ensure that you know how to stop quickly and switch off the engine.

Caution when working on inclines. It is better to work from the bottom to the top of an incline (or from the top to the bottom), rather than across an incline where there is a risk of overturning. Check and heed the instructions supplied by the tractor manufacturer, especially those concerning the maximum incline on which it is possible to work.

It is advisable to reduce speed when working and maneuvering on inclines and only to change speed and direction gradually. Do not make sudden stops or starts.

Do not work on wet or slippery grass or terrain, or anywhere where grip is poor. If this is unavoidable, work at a slow speed so as to ensure operator safety.

Always switch off the tractor engine, apply the parking brake and remove the ignition key whenever you have to attend to the machine to make adjustments or to remove grass and other objects which might be entangled in the machine.

Before leaving the tractor, disengage the power takeoff, lower the machine until its wheels are on the ground and put the hydraulic directional control lever into the locked position.

Never go near the rotors until they have completely stopped moving.

Never attempt to make adjustments to the machine while it is running. Always stop the machine before carrying out any such work. Do not oil the machine when it is running or is connected to the power takeoff.

Do not use the control levers as handholds since they can move and do not give a secure grip. Furthermore, any involuntary movement of a control lever can cause unintentional movement of the tractor or machine.

## 6.6 GENERAL INSTRUCTIONS FOR USE



In addition to the instructions given above, each time you have to make adjustments before and during work, we recommend moving the tractor and machine to a firm, flat open area.

Before getting off the tractor to make adjustments, follow this procedure exactly:

- 1) Lower the machine until its wheels touch the ground (this is recommended every time the tractor is stopped for any reason).
- 2) Put the hydraulic directional control lever on the tractor into the locked position.
- 3) Switch off the engine, leaving the tractor in gear.
- 4) Apply the parking brake.
- 5) Remove the ignition key from the instrument panel.

Now prepare the machine for field use as indicated below.

### 6.6.1 PRELIMINARY CHECK

Ensure that:

- 1) The power takeoff speed is 540 r.p.m. (for special machines made on request, gearboxes are fitted and preset for power takeoff with a speed of 1000/2000 r.p.m.)
- 2) The direction of rotation of the tractor's power takeoff corresponds with that of the gearbox, because the ***cutting blades "A" must rotate in the direction indicated by the arrows.***
- 3) The machine is assembled correctly and in good operating condition by following the instructions of this manual and therefore guaranteeing maximum safety.

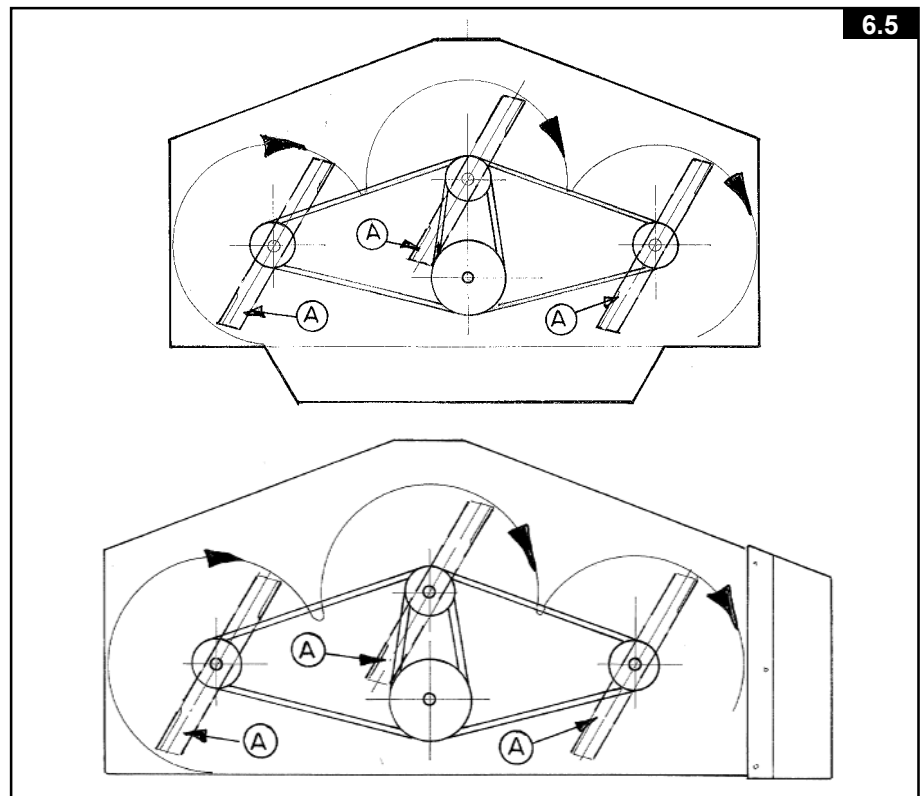

## 6.6.2 ADJUSTING THE CUTTING HEIGHT



The cutting height is determined by the shims 1-2-3-4-5, which are inserted between the wheel unit 6 and the axle 7 in various combinations.

These determine the different cutting positions ranging from a minimum of 15 mm (5/8") to a maximum of 92 mm (3" 7/8).

To carry out this operation you should keep the machine raised.

Remove the split pin 8 which secures the wheel unit 6 to the axle 7.

Then select the position of the shims which allows you to obtain the desired cutting height. Re-lock wheel unit 6 with the split pin 8.

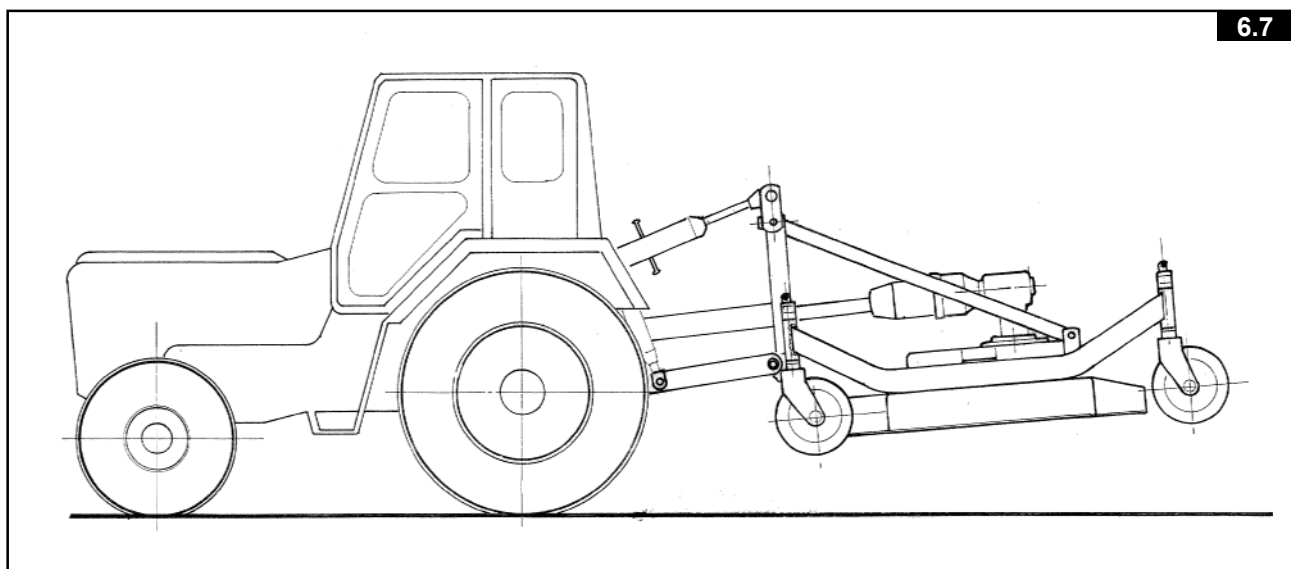
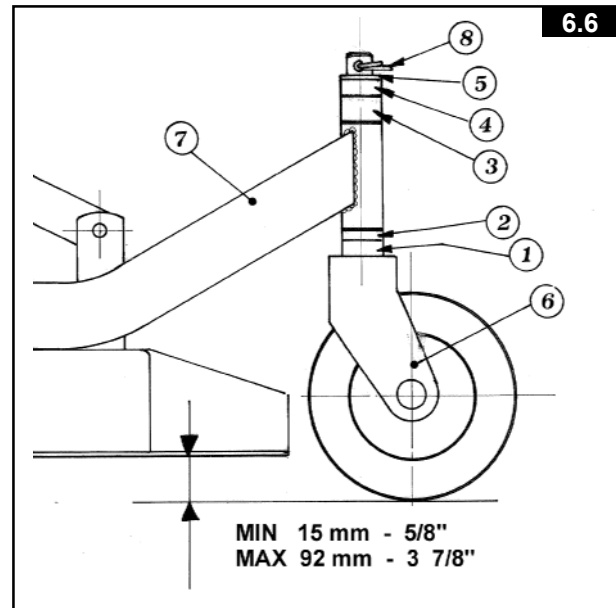

### 6.6.3 ADJUSTING THE MACHINE'S 3-POINT HITCH AND THE TRACTOR'S TRANSPORT ARM

Now lower the machine until the wheels are firmly resting on a solid level surface. By adjusting the various hoist controls of the tractor, position the machine parallel to the ground both longitudinally and transversely. Adjusting the tractor's 3-point hitch 1, make sure that the machine's hitch 2 can move back and forth freely when the machine is level on the ground.

The transport arm 3 should also move up and down freely. Furthermore, the transport arm 3 has two holes "A" and "B" opposite the pin, which enable the operator to attach the machine to any kind of lift.

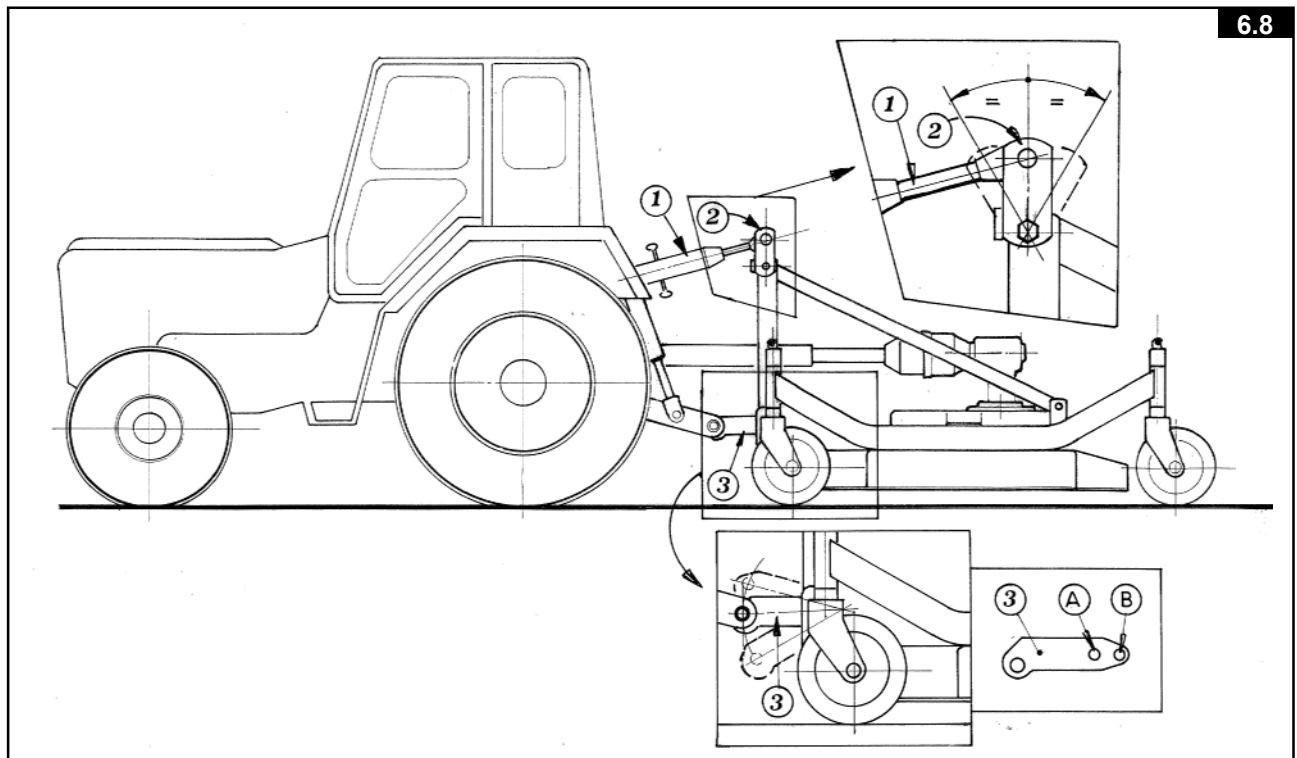

### 6.6.4 ADJUSTING THE BELT TENSION

The machine belts are tightened by the manufacturer, but after the running-in phase or whenever the cutting blades appear not to be functioning properly, it is necessary to re-tighten the belts to the correct tension. To do this one should carry out the following steps:

- a) Remove the screws 1 & 2 and take off the protective guard 3.
- b) Loosen the nuts 4 which secure the slide reduction unit 5.
- c) Loosen the lock nut 6,
- d) Adjust the screw 7 so that the slide reduction unit 5 can move in direction "A" until the belt 8 has a flexure in section "C" equivalent to the flexure "E" indicated in the table.
- e) Now re-tighten the screw 7 with the lock nut 6 and re-secure the slide reduction unit 5 with the nuts 4.
- f) Re-fit the protective guard and secure it with the screws 1 & 2.

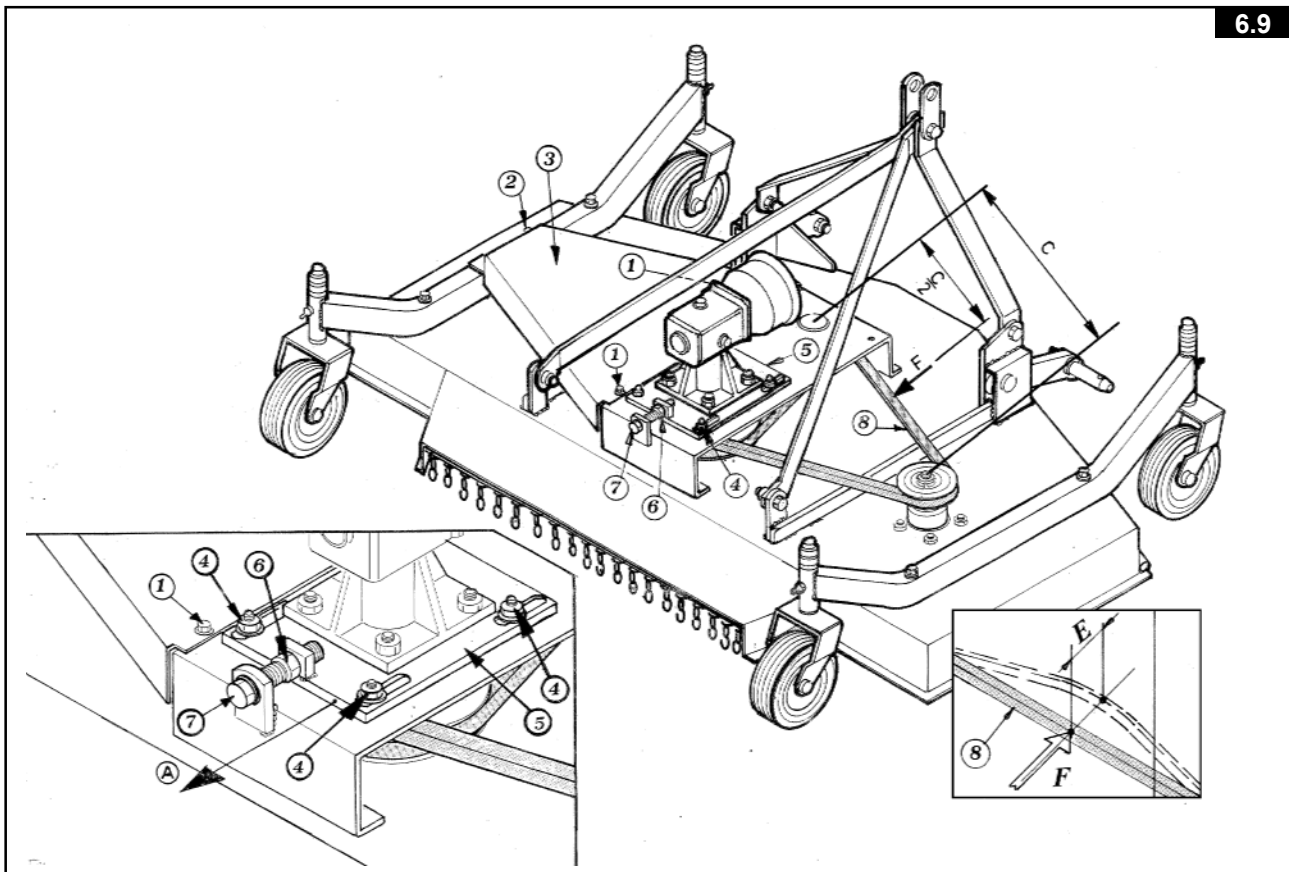



### 6.6.5 GENERAL RULE FOR CALCULATING THE TIGHTNESS OF BELT TYPES SPB / 5V / 15N / XPB / 5VX

For better understanding of general rule for calculating the tightness of belt see Fig.6.9.

$$E \cong \frac{K \cdot C}{100}$$

E = Flexure (mm) of a section of belt (C) subjected to a force (F) equivalent to 75 N (~7.5 kg) applied to the center of the section (C/2).

K = Flexure (mm) of a 100 mm (4") section of belt subjected to a force of 75 N (~7.5 kg) applied to the center of the section.

Diameter of the smallest belt pulley (mm)	Values of K (mm)
80<160	3
160<224	2.55
224<355	2.22
>355	2.1

C = Longer section of belt of transmission (mm).

C/2 = The middle of the longer belt of transmission where the force (F) must be applied (mm).

F = Force applied to check the tension of the belts, equivalent to 75 N (~7.5 kg).

The table below reports the right values for the finishing mowers:

Values of general rule parameters (mm)			
Parameters	Machine Model		
	SM 120	SM 150	SM 180
K	3	3	3
C	422	522	622
E	12.5	15.5	18.5

### 6.6.6 REPLACING THE BLADES



If possible, carry out this operation in a workshop after having detached the machine from the tractor and raised it with a suitable hoist (see page 21). If there is no choice but to carry out the operation on the field, choose a firm, level spot.

- a) Raise the machine to the tractor hoist's maximum height and apply the parking brake.
- b) Disconnect the power takeoff, turn off the tractor and remove the key from the ignition.
- c) Insert a support between the machine and the ground to prevent it from falling.
- d) At this point tighten the hub pin 2 with the wrench 1 and unscrew the nut 4 with the wrench 3.
- e) Then remove the blade 5 and replace it with a new one.
- f) Now re-tighten the nut 4.

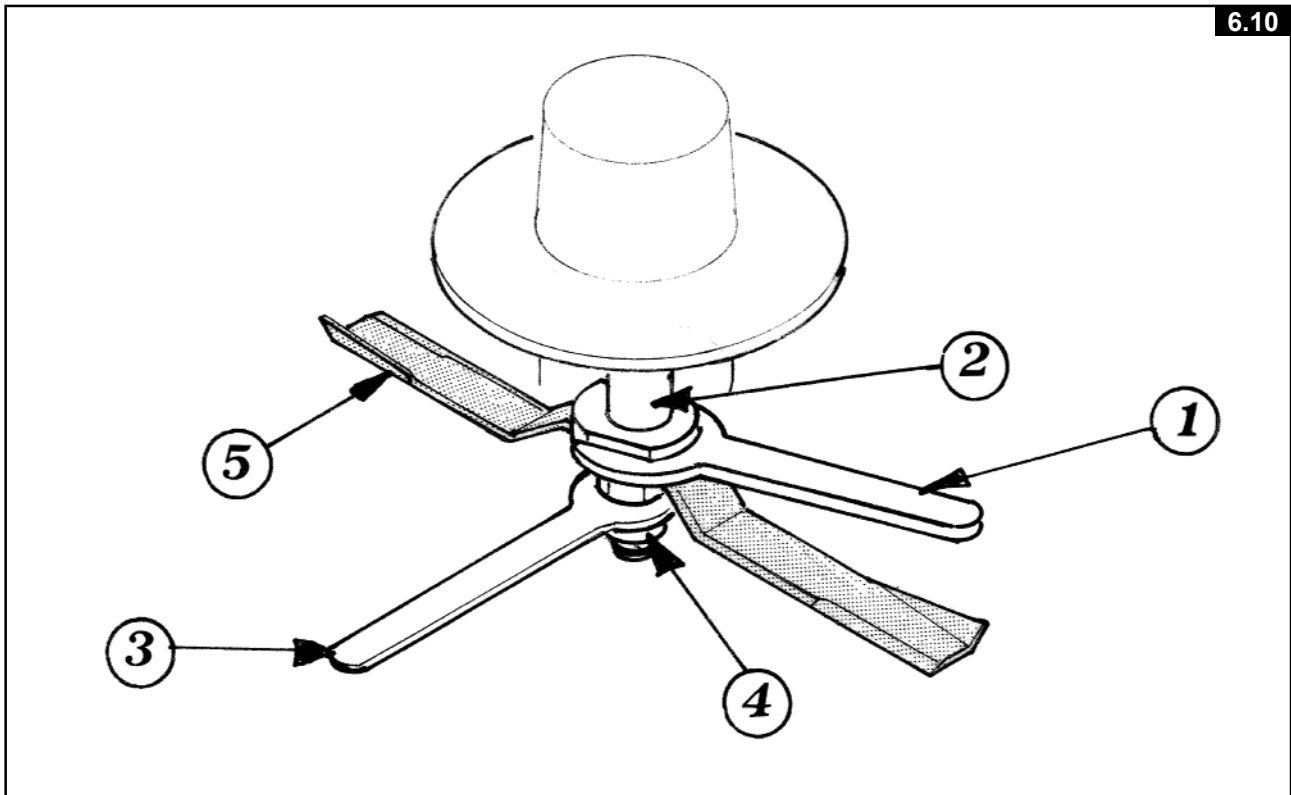

### 6.6.7 TEMPORARY PARKING



If the machine has to be temporarily parked (for extended periods see page 44) proceed as follows, bearing in mind the instructions in CHAPTER 3.

Before getting off the tractor, follow this procedure exactly:

- 1- Choose a flat, hard open space, away from frequented areas if possible.
- 2- Lower, the machine until its wheels touch the ground (this is recommended every time the tractor is stopped for any reason).
- 3- Put the hydraulic directional control lever on the tractor into the locked position.
- 4- Switch off the engine, leaving the tractor in gear.
- 5- Apply the parking brake.
- 6- Remove the ignition key.
- 7- Repeat the operations described on point 6.2 page 32, but in reverse.

## CHAPTER 7

## MAINTENANCE

## 7.1 MAINTENANCE DIRECTIONS

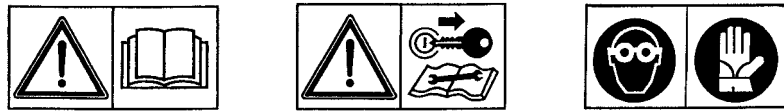

 DANGER !!! 

All cleaning, lubrication and maintenance operations must be carried out with the machine disconnected from the tractor. In an emergency with the machine still connected to the tractor, switch off the engine, apply the parking brake, disengage the power takeoff and remove the ignition key from the instrument panel.

Regular, correct maintenance and proper operation are the basic prerequisites for the long-term efficiency and safe operation of the machine.

Pay special attention to all instructions given on signs located on the machine.

All maintenance should be carried out in an area having the proper equipment readily available and in good condition. This area must always be kept clean and dry and must, have enough surrounding space to facilitate operations.

Any work must be carried out by trained personnel. Contact the dealer nearest to you.

Respect the warnings and procedures for maintenance and technical assistance given in this manual.

Do not use petrol, solvents or other flammable liquids as detergents.

Use commercial non-flammable and non-toxic solvents, authorized by competent bodies.

Do not use compressed air or water at high pressure to clean the machine. If this is unavoidable, then wear goggles with side protection and limit the pressure as much as possible. When the work is finished, and with the machine disconnected from the tractor, inspect and check the machine completely.

## 7.2 REPAIR INSTRUCTIONS

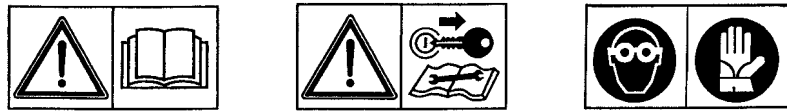

 DANGER !!! 

Any repair work must be carried out with the machine at rest and disconnected from the tractor. Do not carry out welding without authorization and instructions from the manufacturers. Disconnect the machine from the tractor before any welding work in order not to damage the battery. Always use a protective mask, goggles and gloves when welding, sanding or grinding or when using a hammer or drill.

Always work on the machine out of doors. If you have to operate the machine when connected to the tractor in an enclosed area (for example when testing after repair and/or maintenance), ensure that there is sufficient ventilation so as to prevent noxious exhaust gases accumulating.

In order to acquire the necessary control and to operate in safety, practise various manoeuvres by simulating those required in the workplace with the help of an experienced person.

If you activate the machine while it is raised from the ground, make sure there is nobody standing nearby or in a dangerous position.

## 7.3 LAYING UP FOR EXTENDED PERIODS

At the end of the season, or when an extended period of inactivity is envisaged, it is advisable to:

- a) Clean the machine following instructions and allow it to dry.
- b) Check it carefully and replace any damaged or worn parts.
- c) Thoroughly tighten all screws and bolts.
- d) Grease the machine thoroughly and then cover it completely and lay it up in a dry place.

It is to the user's advantage to carry out these operations carefully. In this way, he will have a machine in perfect condition when work is restarted.

On recommencing work, repeat all the proper checks so as to be certain of working in conditions of maximum safety.

## 7.4 MAINTENANCE AND TESTING

To effect the lubrication of the blade hubs 1 and the testing of the belt tension 5, it is necessary to remove the protective guard "A" (see point 6.6.4 page 38).

Once these operations have been completed, re-attach the protective guard "A" properly.

To change (or top up) the oil, remove the caps B & C from the gearbox 3.

Pour the oil into the hole of cap B until it comes out of the hole of cap C, and then put back both caps.

The quantity of oil needed for a complete change is 0.5 litres.

The type of oil used must be in accordance with regulation ISO 320 VG.

The maintenance table specifies how often the oil should be changed.

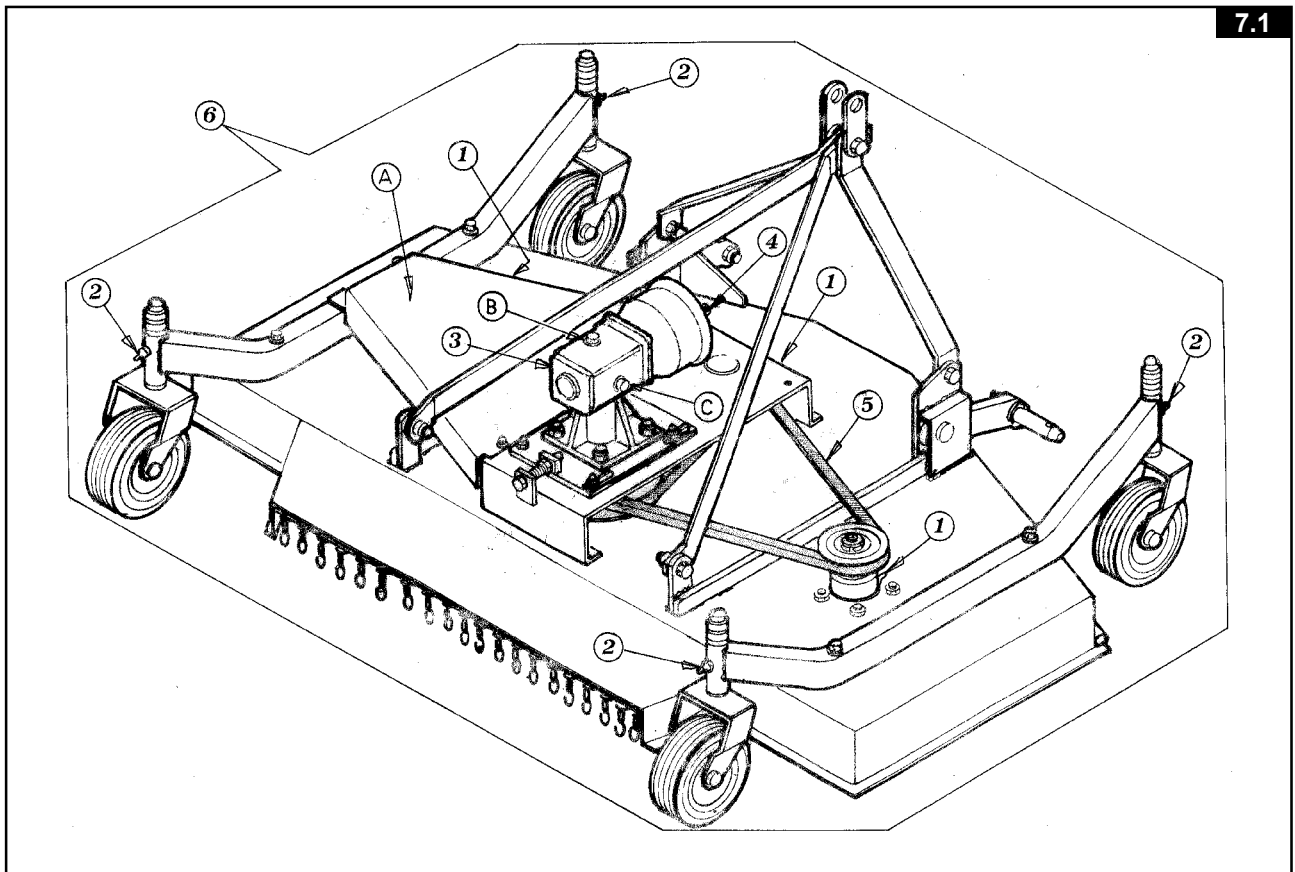

7.1

## 7.5 MAINTENANCE POINTS

No.	Qty.	Description	Operation	Every x hours	Product to use
1	3	Blade hubs	Lubricate	8	Grease *
2	4	Wheel supports	Lubricate	25	Grease *
3	1	Gearbox	Top up or oil change	X	Oil **
4	1	P. T. O. Shaft	Clean	Y	—
5	2	Belts	Check tension	50	See page 39
6	—	General checking of bolts, security pins and split pins to be carried out initially after the first 8 hours of use. Subsequently every 50 hours and whenever the machine is laid up for extended periods.			

Note:

X= First time after 50 hours. Then every 500/800 hours. It is advisable anyhow to replace oil at least once a year. Check oil every 50 hours.

Y= Each time the Cardan shaft is disconnected and whenever the machine is stopped, we recommended that you clean the power takeoff shaft and replace the protective cover.

\* Grease type: NLGI2  
 \*\* Oil type: ISO 320 VG (SAE 80W/90 EP)



## 7.6 CARDAN SHAFT MAINTENANCE

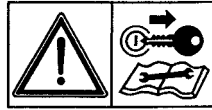
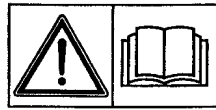

More detailed information may be found in the Cardan shaft manual, which, together with this manual, forms an essential part of the accident-prevention documentation. It is your responsibility to read and comply with this documentation.

If information given in this manual conflicts with that given in the Cardan shaft manual, you should follow the instructions given by the Cardan shaft manufacturer.

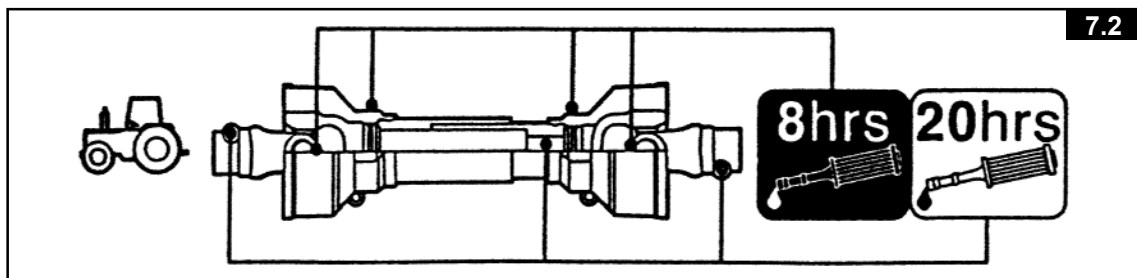

### 7.6.1 MAINTENANCE OF SLIDING PARTS

#### DISMANTLING

Turn the two eccentric pins on the ferrule until the protective cone comes free.

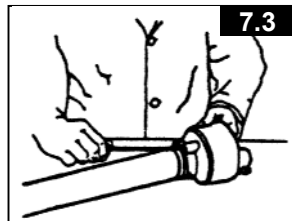

Withdraw the shaft protective guard.

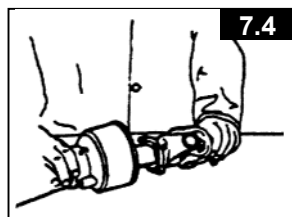

Check the condition of the ferrule and all protective parts.

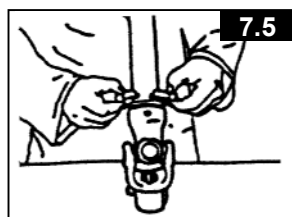

#### ASSEMBLY

Lubricate the supporting ferrule seating.

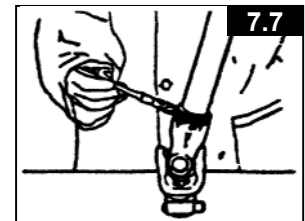

Refit the supporting ferrule.

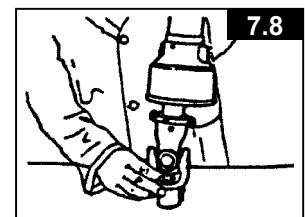

Reattach the protective guard to the Cardan shaft by turning the eccentric pins on the supporting ferrule.

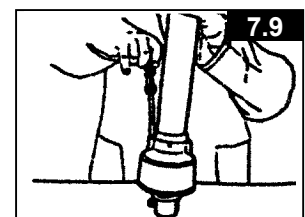

## **7.7 NOISE AND VIBRATION**

Noise affecting the tractor driver (from the machine only) is less than 70 dB.

Vibration from the machine affecting the upper body and limbs of the driver is insignificant and is lower than the values given in Point 3.6.3 of Enclosure 1 of the Machine Directives (89/392/EEC, 91/386/EEC).

## **7.8 SCRAPPING THE MACHINE**

The machine consists mainly of ferrous material which must be disposed of according to the regulations in force in the country concerned.

There is also a small amount of plastic, which must be disposed of according to the regulations in force in the country concerned.

There is a very small amount of residual grease which must be disposed of according to the regulations in force in the country concerned.

## CHAPTER 8

### SPARE PARTS LIST

### 8.1 REAR DISCHARGE FINISHING MOWER

TABLE NO. 920.049

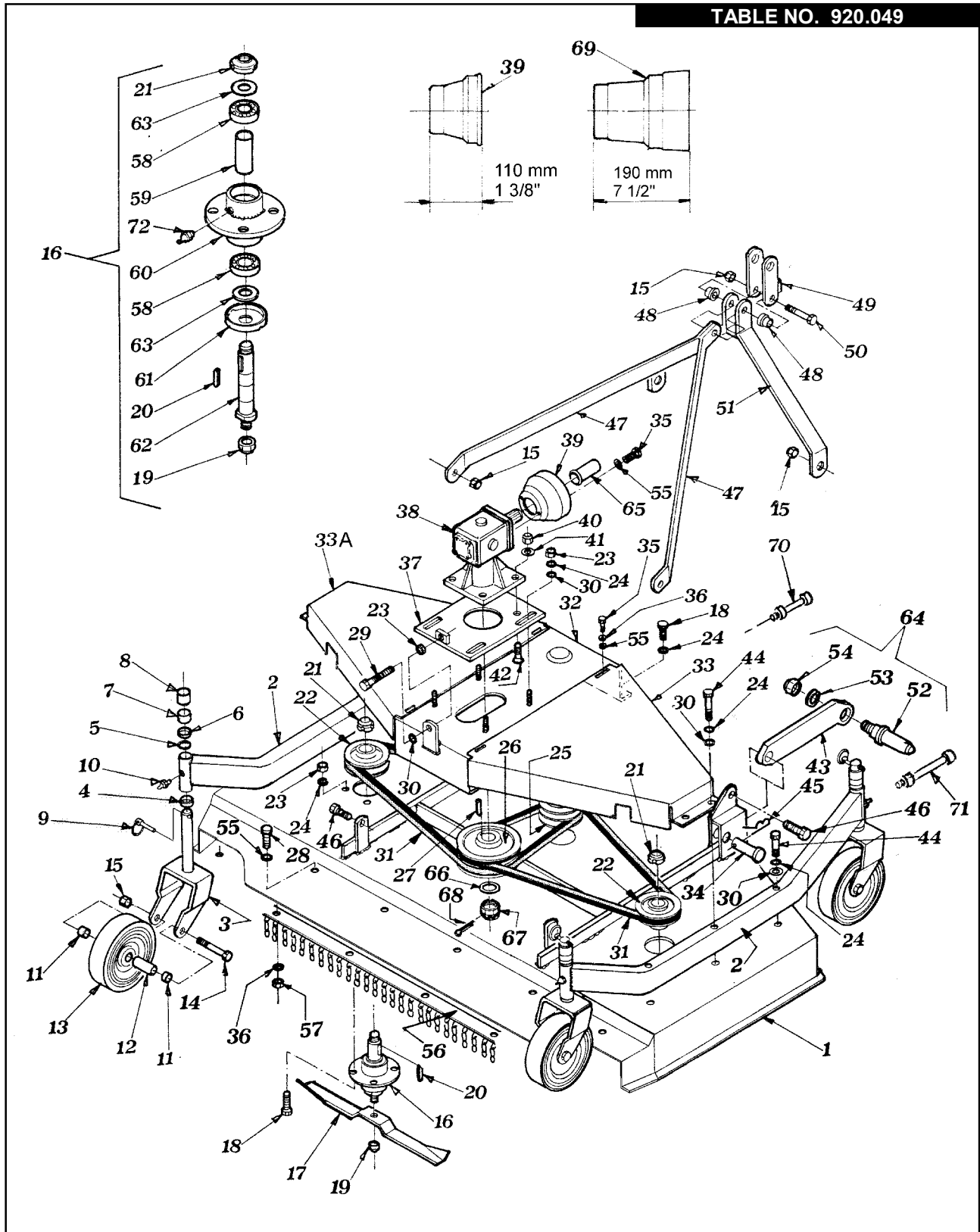

TABLE NO.910.049								
Item	SM/120 P		SM/150 P		SM/180 P		DESCRIPTION	DESCRIPTION
	Part No. Code	Qty	Part No. Code	Qty	Part No. Code	Qty		
1	110.059	1	110.060	1	110.061	1	COMPLETE HOOD	COFFRE COMPLET
2	110.068	2	110.069	2	100.699	2	WHEEL AXLE	ESSIEU ROUE
3	100.020	4	100.020	4	100.020	4	WHEEL SUPPORT	SUPPORT DE ROUE
4	100.044	4	100.044	4	100.044	4	DIST.WASHER 12mm 1/2"	EPAISSEUR 12mm 1/2"
5	100.042	4	100.042	4	100.042	4	DIST.WASHER 2mm 1/16"	EPAISSEUR 2mm 1/16"
6	100.043	4	100.043	4	100.043	4	DIST.WASHER 6mm 1/4"	EPAISSEUR 6mm 1/4"
7	100.045	4	100.045	4	100.045	4	DIST.WASHER 25mm 1"	EPAISSEUR 25mm 1"
8	100.046	4	100.046	4	100.046	4	DIST.WASHER 32mm 1"1/4	EPAISSEUR 32mm 1"1/4
9	600.116	4	600.116	4	600.116	4	SPRING PIN	GOUPILLE
10	600.124	4	600.124	4	600.124	4	GREASE NIPPLE M6	GRAISSEUR
11	100.006	8	100.006	8	100.006	8	SPACER	ENTRETOISE
12	100.008	4	100.008	4	100.008	4	BUSHING	HAPPE
13	600.165	4	600.165	4	600.165	4	WHEEL	ROUE
14	600.156	4	600.156	4	600.156	4	SCREW M12 X110 DIN 931 8.8	VIS
15	600.077	9	600.077	9	600.077	9	NUT M12 DIN 980	ECROU
16	100.047	3	100.047	3	100.047	3	COMPLETE HUB	MOYEU
17	100.064	3	100.065	3	100.066	3	BLADE	LAME
18	600.006	18	600.006	18	600.006	18	SCREW M10 X 25 DIN 933 8.8	VIS
19	600.746	3	600.746	3	600.746	3	NUT M18 X1,5 DIN 980	ECROU
20	600.123	3	600.123	3	600.123	3	LATCH B 8 X 7 X 35 DIN 6888	CLAVETTE
21	600.122	3	600.122	3	600.122	3	SELF LOCK.RING NUT	FRETTE
22	100.060	2	100.058	2	100.058	2	PULLEY	POULIE SIMPLE
23	600.010	17	600.010	17	600.010	17	NUT M10 DIN 934 - 8	ECROU
24	600.102	28	600.102	28	600.102	28	WASHER D 10,5	RONDELLE
25	100.059	1	100.057	1	100.057	1	DOUBLE PULLEY	POULIE DOUBLE
26	100.056	1	100.054	1	100.055	1	DOUBLE PULLEY	POULIE DOUBLE
27	600.181	1	600.181	1	600.181	1	LATCH B10 X 8 X 40 DIN 6888	CLAVETTE
28	600.702	6	600.702	8	600.702	9	SCREW DIN 931 8.8	VIS
29	600.160	1	600.160	1	600.160	1	SCREW M10 X 80 DIN 933 8.8	VIS
30	600.322	11	600.322	11	600.322	11	WASHER D 10,5 DIN 125A	RONDELLE
31	600.141	2	600.139	2	600.140	2	V BELT	COURROIE TRAPEZOID.
32	100.124	1	100.131	1	100.131	1	MULTIPLIER SUPPORT	SUPPORT MULTIPLICAT.
33	100.558	1	100.561	1	100.572	1	BELT COVER, R.H.	Carter de Protection,droite
33A	100.559	1	100.562	1	100.573	1	BELT COVER, L.H.	Carter de Protection,gauche
34	100.040	2	100.040	2	100.040	2	PIN	PIVOT
35	600.061	6	600.061	6	600.061	6	SCREW M 8 X 16 DIN 933 8.8	VIS
36	600.100	8	600.100	9	600.100	10	WASHER D 8,4	RONDELLE
37	100.022	1	100.021	1	100.021	1	MULT.GEAR SKID HOLDER	GLISSIERE PORTE MULTIP.
38	100.273	1	100.273	1	100.273	1	COMPLETE MULTIPLIER	MULTIPLICAT. COMPLETE
39	600.171	1	600.171	1	600.171	1	CAP L.110	COIFFE L.110
40	600.075	4	600.075	4	600.075	4	NUT M14 DIN 980	ECROU
41	600.104	4	600.104	4	600.104	4	WASHER D 15	RONDELLE
42	600.158	4	600.158	4	600.158	4	SCREW M14 X 40 DIN 7991 10.9	VIS
43	100.039	2	100.039	2	100.039	2	SUPPORT	SUPPORT
44	600.162	6	600.162	6	600.162	6	SCREW M10 X 80 DIN 931 8.8	VIS
45	600.019	2	600.019	2	600.019	2	PIN	GOUPILLE
46	600.616	4	600.616	4	600.616	4	SCREW M12 X 35 DIN 933 8.8	VIS
47	100.116	2	100.117	2	100.118	2	TIE ROD	TIRANT
48	100.062	2	100.062	2	100.062	2	SPACER	ENTRETOISE
49	100.115	1	100.115	1	100.115	1	HITCH	ATELLAGE
50	600.152	1	600.152	1	600.152	1	SCREW M12 X 90 DIN 931 8.8	VIS
51	100.119	1	100.120	1	100.120	1	THREE POINT HITCH	ATELLAGE 3EME POINT
52	105.091	2	105.091	2	105.091	2	PIN	AXE
53	600.214	2	600.214	2	600.214	2	WASHER D 23 DIN 127B	RONDELLE
54	600.249	2	600.249	2	600.249	2	NUT M22 X1,5 DIN 934 - 8	ECROU
55	600.115	10	600.115	11	600.115	12	WASHER D 8,4 DIN 125A	RONDELLE
56	110.063	1	110.064	1	110.065	1	PROTECTION CHAIN	PROTECTION
57	600.037	6	600.037	8	600.037	9	NUT	ECROU
58	600.117	6	600.117	6	600.117	6	BEARING 6205 Z	PALIER
59	100.048	3	100.048	3	100.048	3	SPACER	ENTRETOISE
60	100.049	3	100.049	3	100.049	3	HUB BODY	MOYEU
61	100.052	3	100.052	3	100.052	3	BEARING COVER	COUVRE PALIER
62	100.051	3	100.051	3	100.051	3	PIN	PIVOT
63	100.050	6	100.050	6	100.050	6	WASHER	RONDELLE
64	100.010	2	100.010	2	100.010	2	PIN	PIVOT COMPLETE
65	600.172	1	600.172	1	600.172	1	PROTECTION	PROTECTION
66	600.335	1	600.335	1	600.335	1	WASHER D 25 DIN 125A	RONDELLE
67	600.296	1	600.296	1	600.296	1	NUT M24X2 - 6	ECROU
68	600.347	1	600.347	1	600.347	1	SPLIT PIN D 5 X 50 DIN 94 3.6	GOUPILLE
69	600.818	1	600.818	1	600.818	1	CAP L.190	COIFFE L.190
70	100.577	1	100.577	1	100.577	1	GREASE FITTING	ATELLAGE GRAISSEUR
71	100.125	2	100.125	2	100.125	2	GREASE FITTING	ATELLAGE GRAISSEUR
72	600.034	3	600.034	3	600.034	3	GREASE NIPPLE M8	GRAISSEUR

### 8.2 LATERAL DISCHARGE FINISHING MOWER

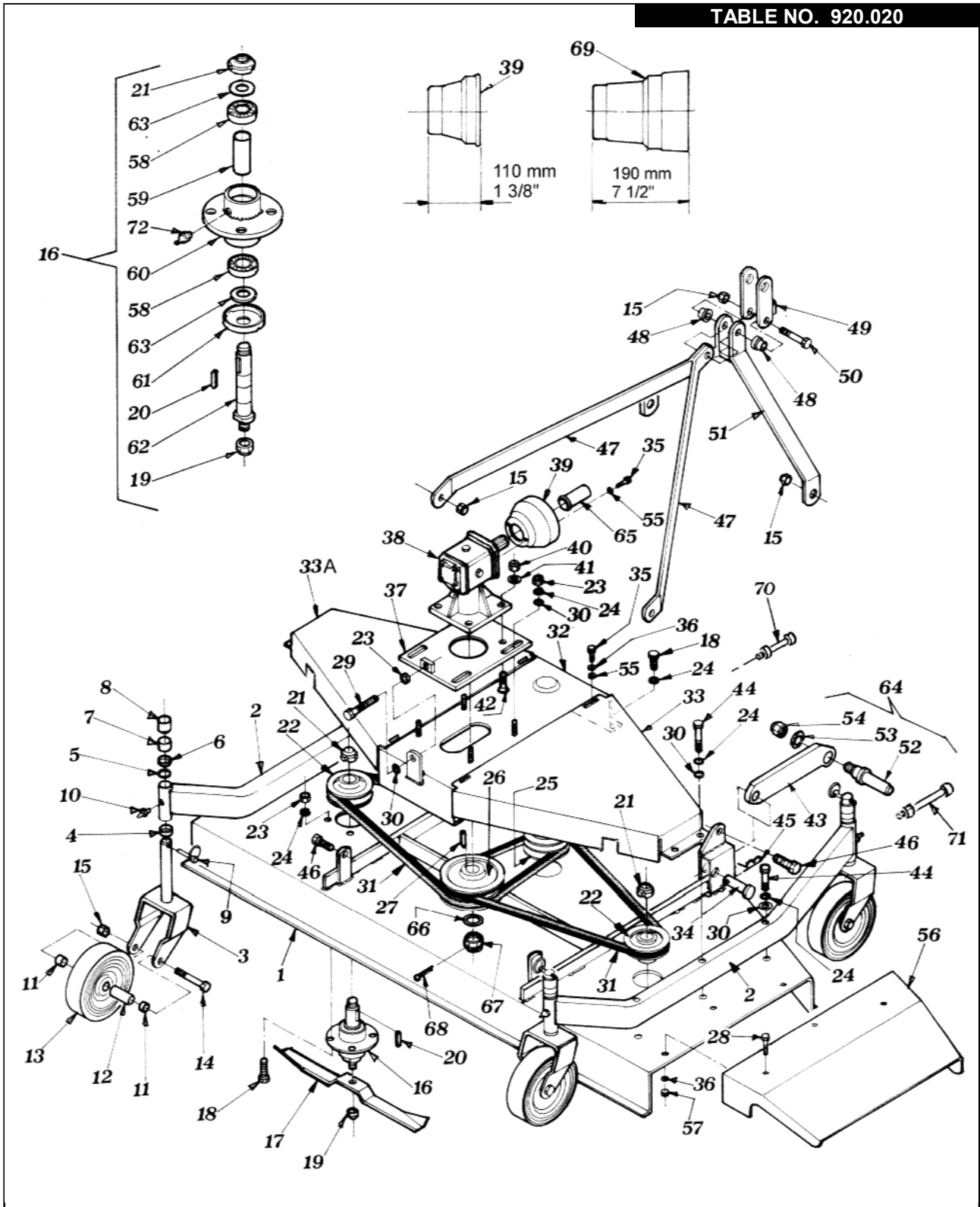
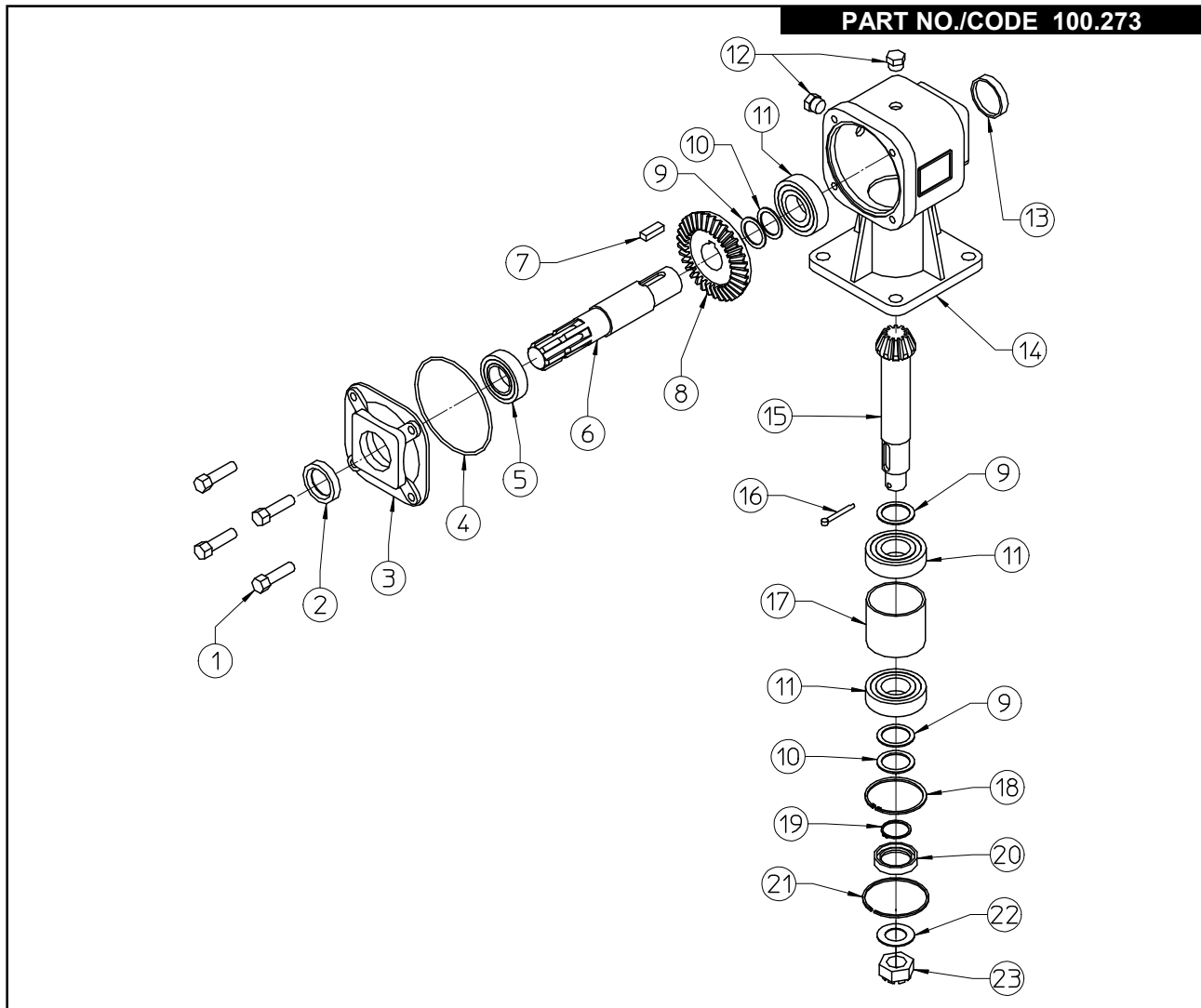

TABLE NO.910.020								
Item Pos.	SM/120 L		SM/150 L		SM/180 L		DESCRIPTION	DESCRIPTION
	Part No. Code	Qty	Part No. Code	Qty	Part No. Code	Qty		
1	100.121	1	100.122	1	100.123	1	COMPLETE HOOD	COFFRE COMPLET
2	100.207	2	100.208	2	100.209	2	WHEEL AXLE	ESSIEU ROUE
3	100.020	4	100.020	4	100.020	4	WHEEL SUPPORT	SUPPORT DE ROUE
4	100.044	4	100.044	4	100.044	4	DIST.WASHER 12mm 1/2"	EPAISSEUR 12mm 1/2"
5	100.042	4	100.042	4	100.042	4	DIST.WASHER 2mm 1/16"	EPAISSEUR 2mm 1/16"
6	100.043	4	100.043	4	100.043	4	DIST.WASHER 6mm 1/4"	EPAISSEUR 6mm 1/4"
7	100.045	4	100.045	4	100.045	4	DIST.WASHER 25mm 1"	EPAISSEUR 25mm 1"
8	100.046	4	100.046	4	100.046	4	DIST.WASHER 32mm 1"1/4	EPAISSEUR 32mm 1"1/4
9	600.116	4	600.116	4	600.116	4	SPRING PIN	GOUPILLE
10	600.124	3	600.124	3	600.124	3	GREASE NIPPLE M6	GRAISSEUR
11	100.006	8	100.006	8	100.006	8	SPACER	ENTRETOISE
12	100.008	4	100.008	4	100.008	4	BUSHING	HAPPE
13	600.165	4	600.165	4	600.165	4	WHEEL	ROUE
14	600.156	4	600.156	4	600.156	4	SCREW M12 X110 DIN 931 8.8	VIS
15	600.077	9	600.077	9	600.077	9	NUT M12 DIN 980	ECROU
16	100.047	3	100.047	3	100.047	3	COMPLETE HUB	MOYEU
17	100.064	3	100.065	3	100.066	3	BLADE	LAME
18	600.006	18	600.006	18	600.006	18	SCREW M10 X 25 DIN 933 8.8	VIS
19	600.746	3	600.746	3	600.746	3	NUT M18 X1,5 DIN 980	ECROU
20	600.123	3	600.123	3	600.123	3	LATCH B 8 X 7 X 35 DIN 6888	CLAVETTE
21	600.122	3	600.122	3	600.122	3	SELF LOCK.RING NUT	FRETTE
22	100.060	2	100.058	2	100.058	2	PULLEY	POULIE SIMPLE
23	600.010	17	600.010	17	600.010	17	NUT M10 DIN 934 - 8	ECROU
24	600.102	28	600.102	28	600.102	28	WASHER D 10,5	RONDELLE
25	100.059	1	100.057	1	100.057	1	DOUBLE PULLEY	POULIE DOUBLE
26	100.056	1	100.054	1	100.055	1	DOUBLE PULLEY	POULIE DOUBLE
27	600.181	1	600.181	1	600.181	1	LATCH B10 X 8 X 40 DIN 6888	CLAVETTE
28	600.223	3	600.223	3	600.223	3	SCREW M 8 X 20 DIN 933 8.8	VIS
29	600.160	1	600.160	1	600.160	1	SCREW M10 X 80 DIN 933 8.8	VIS
30	600.322	11	600.322	11	600.322	11	WASHER D 10,5 DIN 125A	RONDELLE
31	600.141	2	600.139	2	600.140	2	V BELT	COURROIE TRAPEZOID.
32	100.124	1	100.131	1	100.131	1	MULTIPLIER SUPPORT	SUPPORT MULTIPLICAT.
33	100.558	1	100.561	1	100.572	1	BELT COVER, R.H.	Carter de Protection,droite
33A	100.559	1	100.562	1	100.573	1	BELT COVER, L.H.	Carter de Protection,gauche
34	100.040	2	100.040	2	100.040	2	PIN	PIVOT
35	600.061	6	600.061	6	600.061	6	SCREW M 8 X 16 DIN 933 8.8	VIS
36	600.100	7	600.100	7	600.100	7	WASHER D 8,4	RONDELLE
37	100.022	1	100.021	1	100.021	1	MULT.GEAR SKID HOL.	GLISSIERE PORTE MULT.
38	100.273	1	100.273	1	100.273	1	COMPLETE MULTIPL.	MULTIPLICAT. COMPL.
39	600.171	1	600.171	1	600.171	1	CAP L.110	COIFFE L.110
40	600.075	4	600.075	4	600.075	4	NUT M14 DIN 980	ECROU
41	600.104	4	600.104	4	600.104	4	WASHER D 15	RONDELLE
42	600.158	4	600.158	4	600.158	4	SCREW M14 X 40 DIN 7991 10.9	VIS
43	100.039	2	100.039	2	100.039	2	SUPPORT	SUPPORT
44	600.162	6	600.162	6	600.162	6	SCREW M10 X 80 DIN 931 8.8	VIS
45	600.019	2	600.019	2	600.019	2	PIN	GOUPILLE
46	600.616	4	600.616	4	600.616	4	SCREW M12 X 35 DIN 933 8.8	VIS
47	100.116	2	100.117	2	100.118	2	TIE ROD	TIRANT
48	100.062	2	100.062	2	100.062	2	SPACER	ENTRETOISE
49	100.115	1	100.115	1	100.115	1	HITCH	ATELLAGE
50	600.152	1	600.152	1	600.152	1	SCREW M12 X 90 DIN 931 8.8	VIS
51	100.119	1	100.120	1	100.120	1	THREE POINT HITCH	ATELLAGE 3EME POINT
52	105.091	2	105.091	2	105.091	2	PIN	AXE
53	600.214	2	600.214	2	600.214	2	WASHER D 23 DIN 127B	RONDELLE
54	600.249	2	600.249	2	600.249	2	NUT M22 X1,5 DIN 934 - 8	ECROU
55	600.115	8	600.115	8	600.115	8	WASHER D 8,4 DIN 125A	RONDELLE
56	100.029	1	100.028	1	100.027	1	LATERAL CONVEYOR	CONVOYEUR LATERAL
57	600.037	3	600.037	3	600.037	3	NUT M 8 DIN 934 - 8	ECROU
58	600.117	6	600.117	6	600.117	6	BEARING 6205 Z	PALIER
59	100.048	3	100.048	3	100.048	3	SPACER	ENTRETOISE
60	100.049	3	100.049	3	100.049	3	HUB BODY	MOYEU
61	100.052	3	100.052	3	100.052	3	BEARING COVER	COUVRE PALIER
62	100.051	3	100.051	3	100.051	3	PIN	PIVOT
63	100.050	6	100.050	6	100.050	6	WASHER	RONDELLE
64	100.010	2	100.010	2	100.010	2	PIN	PIVOT COMPLETE
65	600.172	1	600.172	1	600.172	1	PROTECTION	PROTECTION
66	600.335	1	600.335	1	600.335	1	WASHER D 25 DIN 125A	RONDELLE
67	600.296	1	600.296	1	600.296	1	NUT M24X2 - 6	ECROU
68	600.347	1	600.347	1	600.347	1	SPLIT PIN D 5 X 50 DIN 94 3.6	GOUPILLE
69	600.818	1	600.818	1	600.818	1	CAP L.190	COIFFE L.190
70	100.577	1	100.577	1	100.577	1	GREASE FITTING	ATELLAGE GRAISSEUR
71	100.125	2	100.125	2	100.125	2	GREASE FITTING	ATELLAGE GRAISSEUR
72	600.034	3	600.034	3	600.034	3	GREASE NIPPLE M8	GRAISSEUR

### 8.3 MULTIPLIER GEARBOX



MULTIPLIER/MOULTIPLICATER R.P.M.540 Anti-Clockwise Part No./Code 100.273					
Item Pos.	Part No. Code	Q.ty	DESCRIPTION	DESCRIPTION	NOTE
1	600.054	4	SCREW	VIS	
2	600.346	1	RING	SEGMENT	
3	100.272	1	COVER	BOUCHON	
4	600.345	1	OR GASKET	JOINT	
5	600.342	1	BEARING	PALIER	
6	100.268	1	P.TO SHAFT	ARBRE	
7	600.325	1	LATCH	CLAVETTE	
8	100.269	1	RING BEVEL GEAR	COURONNE CONIQUE	
9	200.274	3	SHIM	EPAISSEUR	
10	200.490	2	SHIM	EPAISSEUR	
11	600.327	3	BEARING	PALIER	
12	600.341	2	PLUG	BOUCHON	
13	600.328	1	CAP	CAPSULE	
14	100.267	2	GEARBOX	BOITE	
15	100.271	1	PINION	PIGNON	
16	600.347	1	SPLIT PIN	GOUPILLE	
17	100.270	1	SPACER	ENTRETOISE	
18	600.332	1	SNAP RING	SEGMENT ARRET	
19	600.333	1	SNAP RING	SEGMENT ARRET	
20	600.338	1	RING	SEGMENT	
21	600.337	1	RING	SEGMENT	
22	600.335	1	WASHER	RONDELLE	
23	600.296	1	NUT	ECROU	



## 8.4 SPECIAL MODELS

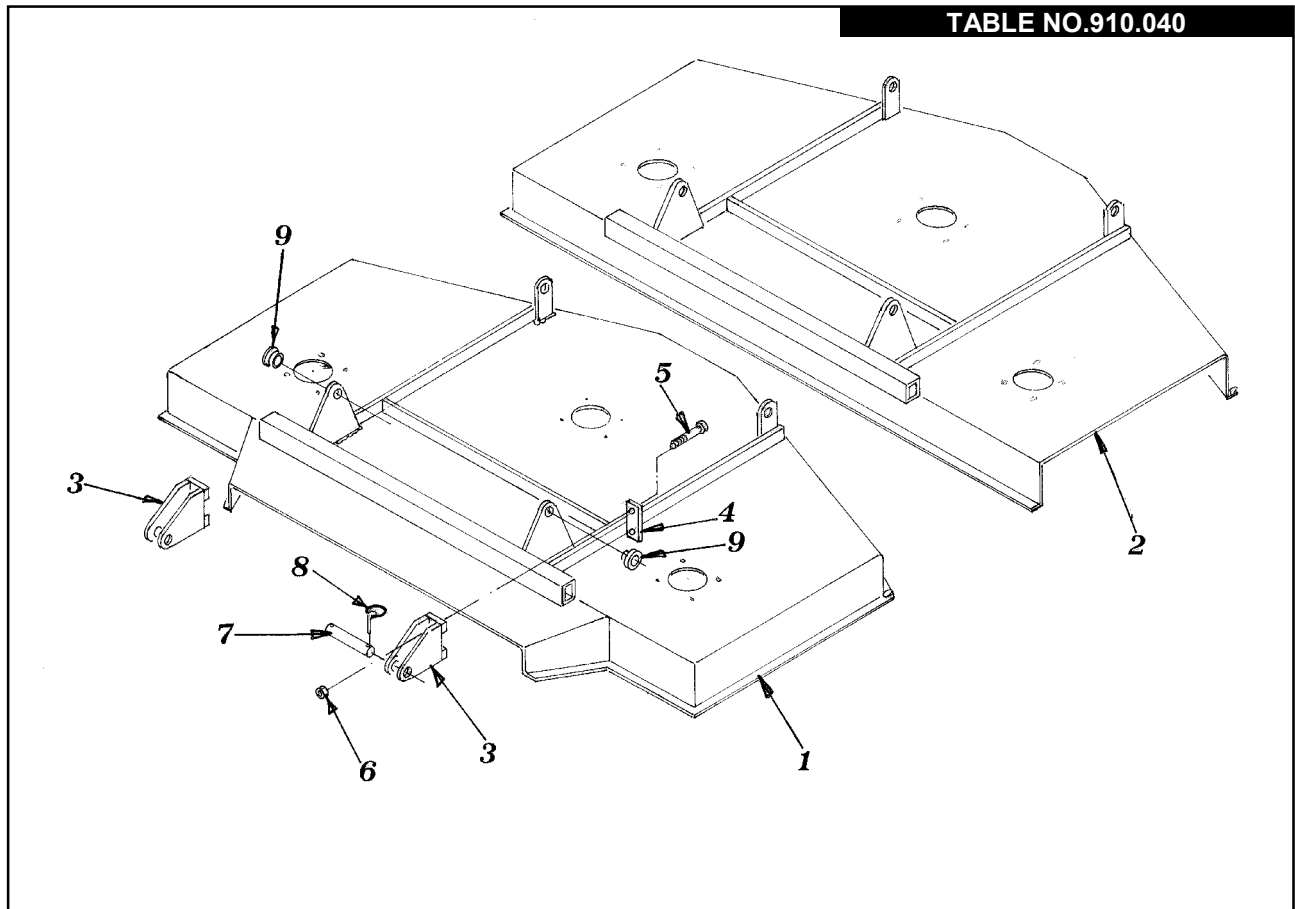
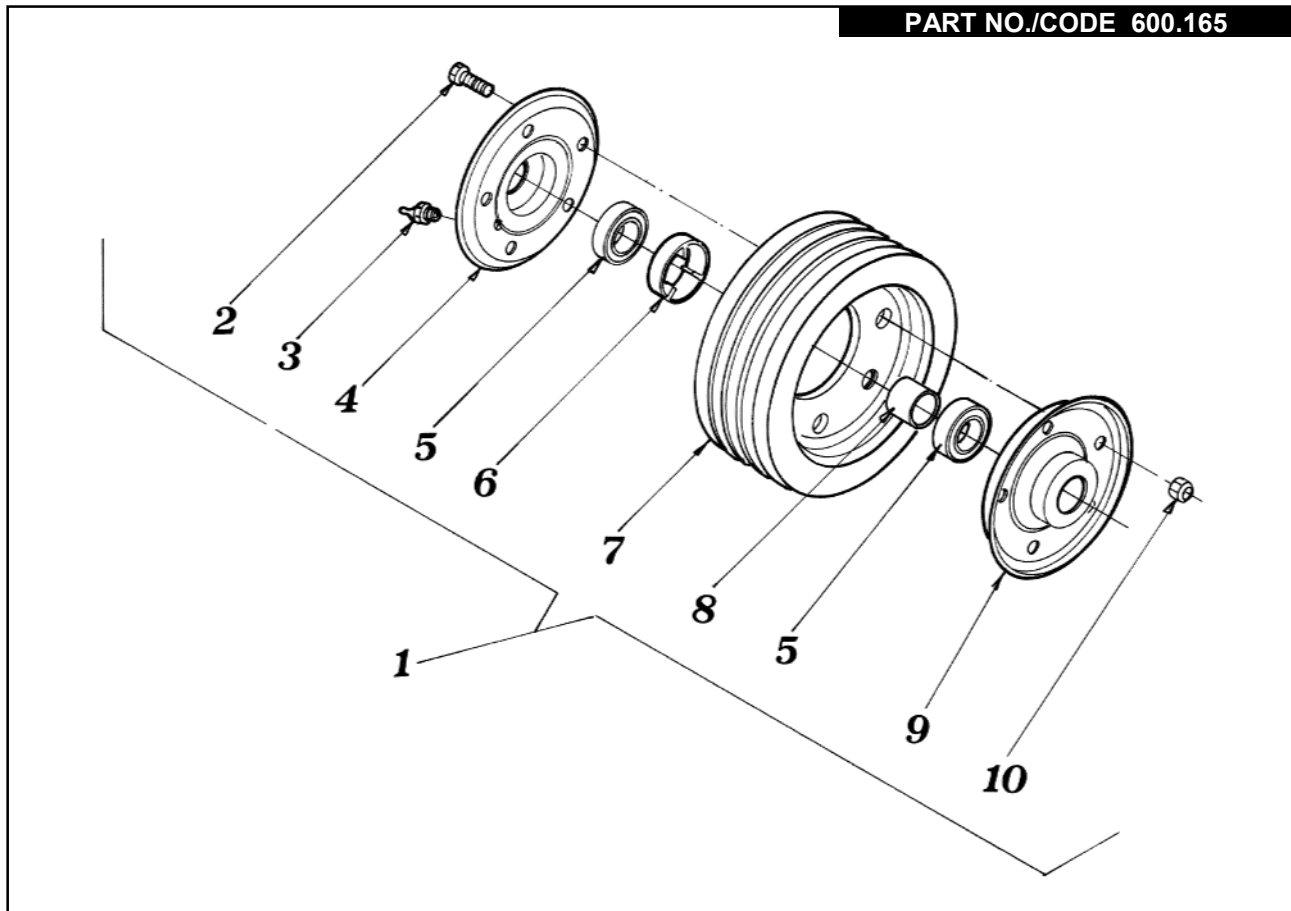

**TABLE NO. 910.040**

Item Pos.	Part No. Code	Q.ty	DESCRIPTION	DESCRIPTION	NOTE
1	110.117	1	COMPLETE HOOD	COFFRE COMPLET	120/P
1	110.116	1	COMPLETE HOOD	COFFRE COMPLET	150/P
1	110.115	1	COMPLETE HOOD	COFFRE COMPLET	180/P
1	110.114	1	COMPLETE HOOD	COFFRE COMPLET	230/P
2	100.084	1	COMPLETE HOOD	COFFRE COMPLET	120/L
2	100.085	1	COMPLETE HOOD	COFFRE COMPLET	150/L
2	100.086	1	COMPLETE HOOD	COFFRE COMPLET	180/L
3	100.079	2	HITCH	ATTELAGE	120/150/180
3	100.317	2	HITCH	ATTELAGE	230/P
4	100.080	2	COUNTER PLATE	CONTRE-PLATE	120/150/180
4	100.330	2	COUNTER PLATE	CONTRE-PLATE	230/P
5	600.210	4	SCREW	VIS	120/150/180
5	600.390	4	SCREW	VIS	230/P
6	600.077	4	NUT	ECROU	
7	100.102	2	PIN	PIVOT	
8	600.017	4	PIN	GOUPILLE	
9	105.113	2	BUSH	HAPPE	

NOTE: ITEMS FOR THE FRONT MOUNT MOWER  
 FOR THE OTHER ITEMS SEE TABLES NOS.910.002/910.020/910.021  
 PIECE POUR LA VERSION FRONTALE  
 POUR LES AUTRES PIECES VOIR TABLES 910.002/910.020/910.021

### 8.5 COMPLETE WHEEL



COMPLET WHEEL/ROUE COMPLETE PART NO./CODE 600.165					
Item Pos.	Part No. Code	Q.ty	DESCRIPTION	DESCRIPTION	NOTE
1	600.165	1	COMPLET WHEEL	ROUE COMPLETE	
2	600.766	5	SCREW	VIS	
3	600.124	1	GREASE NIPPLE	GRAISSEUR	
4	600.764	1	HALF RIM	DEMI-CIRCLE	
5	600.117	2	BEARING	PALIER	
6	100.129	1	BUSH	HAPPE	
7	600.763	1	WHEEL	ROUE	
8	100.128	1	SPACER	ENTRETOISE	
9	600.765	1	HALF RIM	DEMI-CIRCLE	
10	600.046	5	NUT	ECROU	

### 8.6 CARDAN SHAFT (E2 090 E)

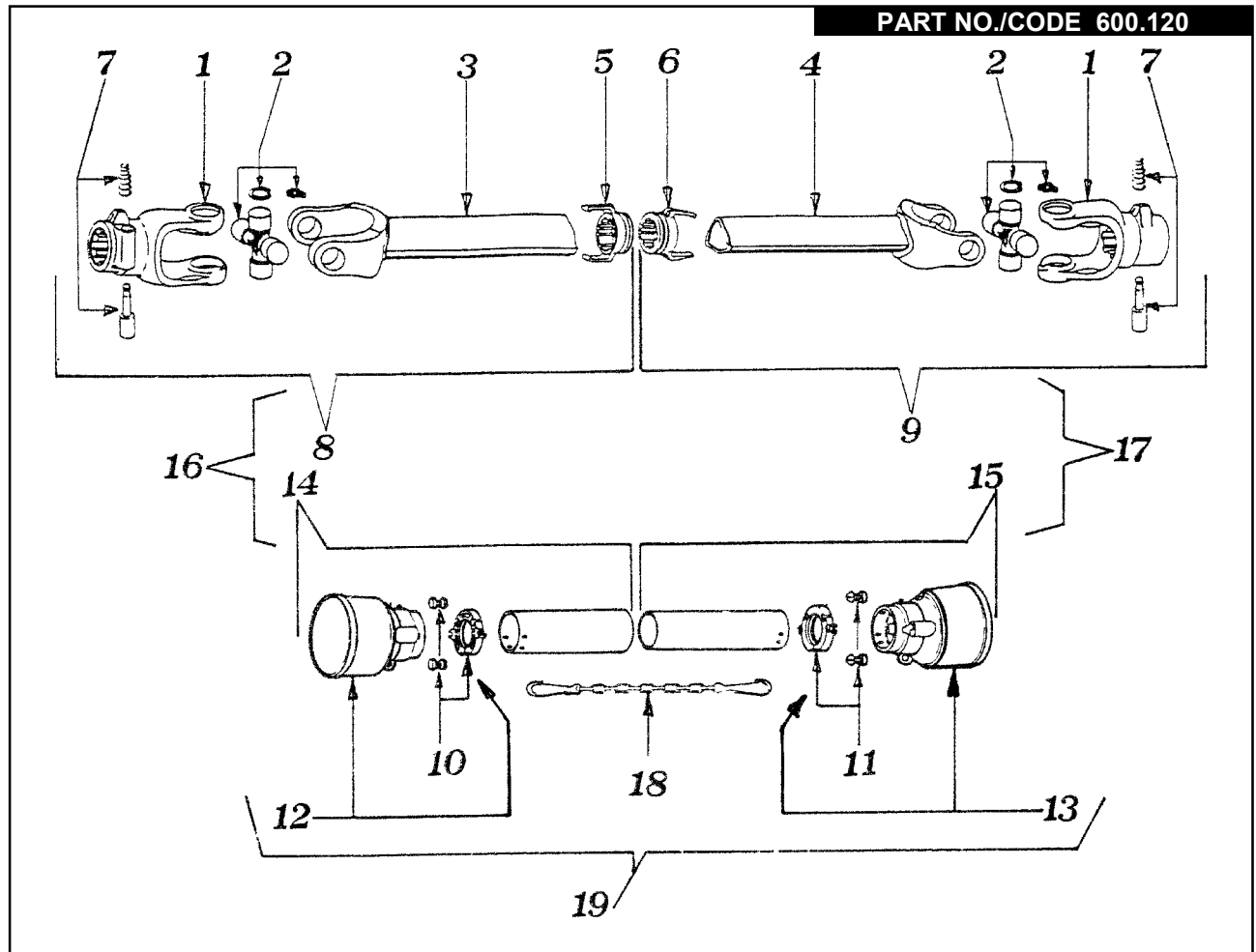

CARDAN SHAFT/ARBRE A CARDAN Part No. 600.120					
Item Pos.	Part No. Code	Q.ty	DESCRIPTION	DESCRIPTION	NOTE
1	610.051	2	YOKE	FOURCHE	
2	610.052	2	CROSS JOURNAL ASS.	CROISILLION COMPLET	
3	610.053	1	YOKE WITH OUTER TUBE	FOURCHE AVEC TUYAU EXT.	
4	610.054	1	YOKE WITH INNER TUBE	FOURCHE AVEC TUYAU INT.	
5	610.055	1	RING FOR OUTER TUBE	BAGUE EXT.	
6	610.056	1	RING FOR INNER TUBE	BAGUE INT.	
7	610.057	2	COMPLETE PUSH BUTTON	POUSSOIR COMPLET	
8	610.058	1	HALF SHAFT-WITHOUT GUARD	MOITIE ARBRE EXT.SANS PROT.	
9	610.059	1	HALF SHAFT-WITHOUT GUARD	MOITIE ARBRE INT.SANS PROT.	
10	610.060	1	OUTER BEARING	FRETTE EXT.	
11	610.061	1	INNER BEARING	FRETTE INT.	
12	610.062	1	OUTER BASIC CONE	COIFFE COMPLETE EXT.	
13	610.063	1	INNER BASIC CONE	COIFFE COMPLETE INT.	
14	610.064	1	OUTER HALF GUARD	MOITIE PROTECTION EXT.	
15	610.065	1	INNER HALF GUARD	MOITIE PROTECTION INT.	
16	610.066	1	OUTER HALF SHAFT-WITH GUARD	MOITIE ARBRE EXT.AVEC PROT.	
17	610.067	1	INNER HALF SHAFT- WITH GUARD	MOITIE ARBRE INT. AVEC PROT.	
18	610.068	1	CHAIN	CHAINE	
19	610.069	1	COMPLETE GUARD	PROTECTION	

8.7 CARDAN SHAFT (B2 090 B)

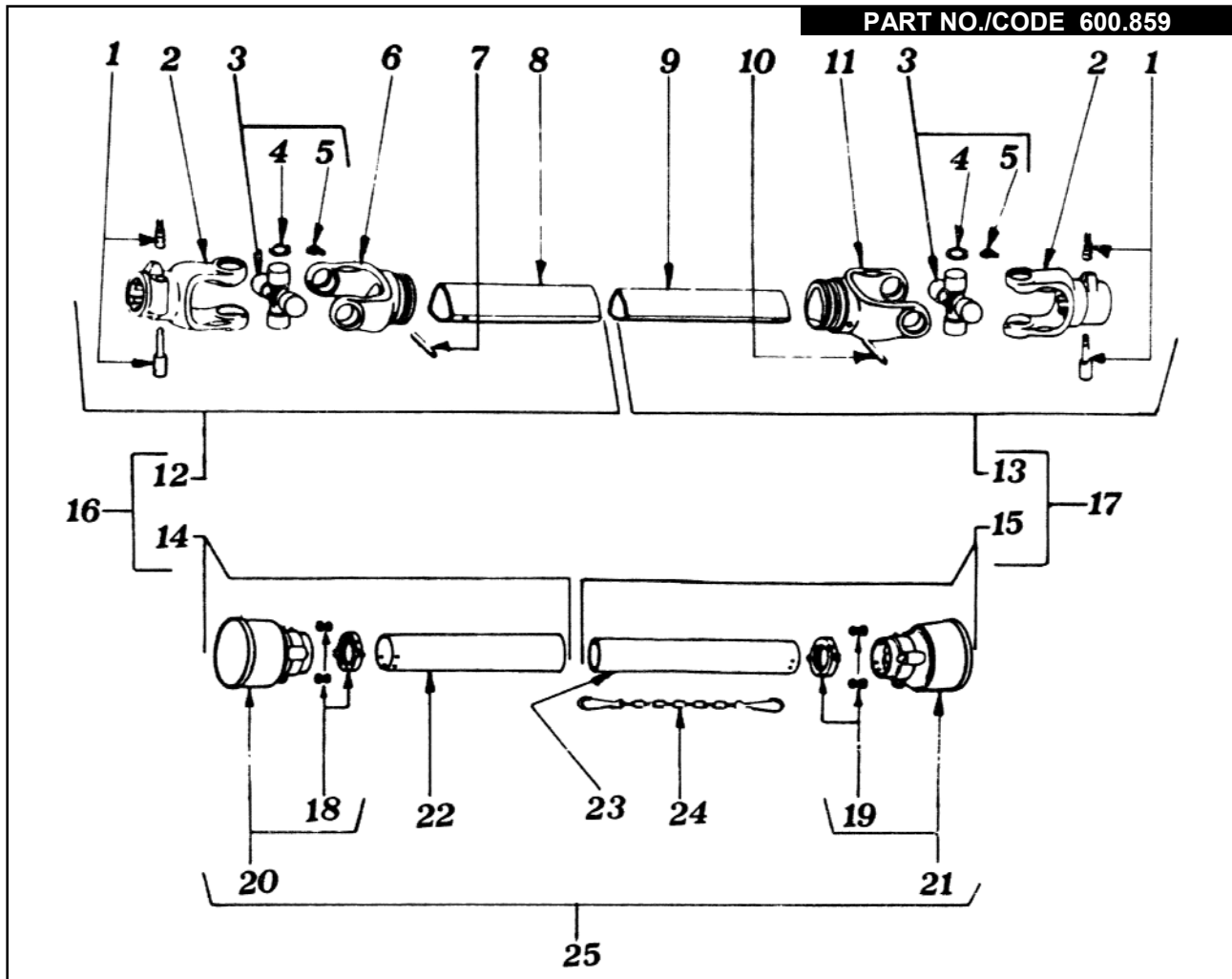

CARDAN SHAFT/ARBRE A CARDAN Part No. 600.859					
Item Pos.	Part No. Code	Q.ty	DESCRIPTION	DESCRIPTION	NOTE
1	610.057	2	COMPLETE PUSH BUTTON	POUSOIR COMPLET	
2	610.051	2	YOKE	FOURCHE	
3	610.052	2	CROSS JOURNAL ASS.	CROISILLION COMPLET	
4	610.248	8	CIRCLIP	BAGUE	
5	610.206	2	GREASE NIPPLE	GRAISSEUR	
6	610.249	1	OUTER TUBE YOKE	FOURCHE TUYAU EXT.	
7	610.211	1	FLEXIBLE PIN	GOUPILLE	
8	610.210	1	CM. CARDAN TUBE	TUYAU CARDAN	
9	610.123	1	CM. CARDAN TUBE	TUYAU CARDAN	
10	600.027	1	FLEXIBLE PIN	GOUPILLE	
11	610.250	1	INNER TUBE YOKE	FOURCHE TUYAU INTERIEUR	
12	610.404	1	HALF SHAFT (WITHOUT GUARD)	MOITIE ARBRE EXT.SANS PROT.	
13	610.405	1	HALF SHAFT (WITHOUT GUARD)	MOITIE ARBRE INT.SANS PROT.	
14	610.406	1	HALF SAFETY GUARD	MOITIE PROTECTION EXT.	
15	610.407	1	HALF SAFETY GUARD	MOITIE PROTECTION INT.	
16	610.408	1	HALF SHAFT (WITH GUARD)	MOITIE ARBRE EXT.AVEC PROT.	
17	610.409	1	HALF SHAFT (WITH GUARD)	MOITIE ARBRE INT.AVEC PROT.	
18	610.398	1	O. BEARING	FRETTE	
19	610.399	1	I. BEARING	FRETTE	
20	610.400	1	O. BASIC CONE	COIFFE COMPLETE EXT.	
21	610.401	1	I. BASIC CONE	COIFFE COMPLETE INT.	
22	610.402	1	CM. SAFETY TUBE	TUYAU PROTECTION EXT.	
23	610.403	1	CM. SAFETY TUBE	TUYAU PROTECTION INT.	
24	610.068	2	CHAIN	CHAINE	
25	610.410	1	SAFETY GUARD	PROTECTION	

## 8.8 ANTI-SCALPING ROLLER KIT (OPTIONAL)

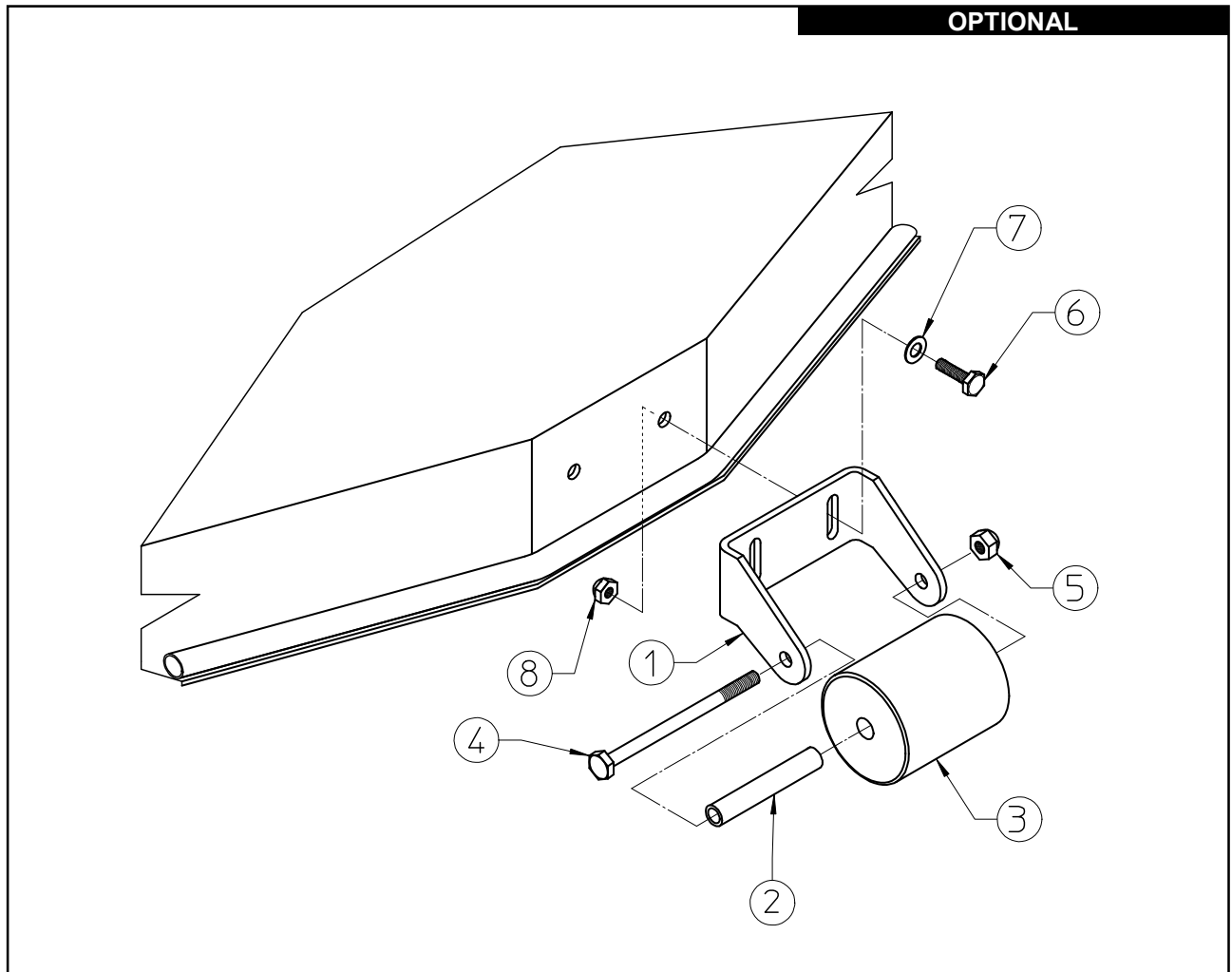

ANTI-SCALPING ROLLER KIT (OPTIONAL)					
Item Pos.	Part No. Code	Q.ty	DESCRIPTION	DESCRIPTION	NOTE
1	100.258	1	SUPPORT	SUPPORT	SM/120-150-180
1	100.263	1	SUPPORT	SUPPORT	SM/230
2	100.259	1	SPACER	ENTRETOISE	SM/120-150-180
2	100.504	1	SPACER	ENTRETOISE	SM/230
3	100.260	1	ROLLER	ROULEAU	SM/120-150-180
3	100.505	1	ROLLER	ROULEAU	SM/230
4	600.807	1	SCREW M12x160 UNI 5737	VIS M12x 160 UNI 5737	SM/120-150-180
4	610.676	1	SCREW M12x220 UNI 5737	VIS M12x220 UNI 5737	SM/230
5	600.077	1	NUT M12 DIN 980 KL 8	ECROU M12 DIN 980 KL 8	
6	600.006	2	SREW M10x25 UNI 5739 8.8	VIS M10x25 UNI 5739 8.8	
7	600.322	2	WASHER D.10.5 UNI 6592 ZN	RONDELLE D.10.5 UNI 6592 ZN	
8	600.029	2	NUT M10 DIN 980 KL 8 ZN	ECROU M10 DIN 980 KL 8 ZN	SM/120-150-180
*	100.364	1	ANTI SCALPING KIT ,COMPLETE	GROUPE ROULEAU FRONTALE	SM/120-150-180
*	100.503	1	ANTI SCALPING KIT ,COMPLETE	GROUPE ROULEAU FRONTALE	SM/230

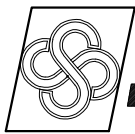

AGRICULTURAL MACHINERY  
**sitrex**® SpA .

Zona Industriale-Viale Grecia, 8  
06018 TRESTINA-(Perugia)-ITALY  
Tel. +39.075.8540021-Telefax +39.075.8540523  
e-mail: [sitrex@sitrex.it](mailto:sitrex@sitrex.it) [www.sitrex.com](http://www.sitrex.com)

