

OPERATOR'S MANUAL
AND
SET-UP INSTRUCTIONS
FOR THE

RBH-200-3 Series

232 Through 236 Models

VERSION: 9-12

Serial Number 16648 through 17875

TO THE OWNER AND OPERATORS

Before assembling or operating this unit, READ THIS MANUAL THOROUGHLY. To obtain the best performance of the unit, familiarize yourself with each component and adjustment. Store this manual where it can be readily available for future reference. In the event that the harrow or any part of the unit should be sold, be sure that the new owner receives a copy of this manual for their reference.

TABLE OF CONTENTS

INTRODUCTION	3
LIMITED WARRANTY	3
SAFETY	4
CONTACT INFORMATION.....	5
LIGHTING AND MARKING.....	6
SAFETY SIGN CARE	7
TIRE SAFETY.....	7
BEFORE OPERATION.....	7 - 8
DURING OPERATION	8 - 9
FOLLOWING OPERATION	9
HIGHWAY AND TRANSPORT OPERATIONS	9 - 10
PERFORMING MAINTENANCE	10
MAINTENANCE AND SERVICE SCHEDULE	11
OPERATING SUGGESTIONS.....	11
ASSEMBLY SUGGESTIONS	12
ASSEMBLY INSTRUCTIONS	13 – 21
FINAL ADJUSTMENTS	22
TROUBLESHOOTING.....	23
BOLT TORQUE SPECIFICATIONS	APPENDIX A
PARTS DIAGRAMS AND LISTS	APPENDIX B
LAYOUT DIAGRAMS.....	APPENDIX C
WARRANTY REGISTRATION FORM	LAST PAGE

INTRODUCTION

Thank you for purchasing your new McFarlane transport cart and harrow sections. We know that you will get many years of dependable service from this modernly designed unit.

You may have had a particular application in mind when you purchased this unit. There are actually many uses for the McFarlane harrow including incorporation of herbicides and pesticides, leveling and smoothing tilled soil, and covering of broadcast seeds. Contact your dealer if you would like more information or have questions concerning these or other applications.

LIMITED WARRANTY

FULL ONE - YEAR WARRANTY OF RBH-200 Series

If within one year from the date of purchase, this transport cart and/or its accompanying harrow sections fail due to defect in material or workmanship, McFarlane Mfg. Co., Inc. will repair it, free of charge.

Warranty service is available by simply contacting the nearest McFarlane dealership throughout the United States or Canada.

This warranty applies only while this product is used in the United States or Canada.

This warranty gives you specific legal rights, and you may have other rights which vary from state to state.

McFarlane Mfg. Co., Inc., Sauk City, Wisconsin 53583

SAFETY

TAKE NOTE! THIS SAFETY ALERT SYMBOL FOUND THROUGHOUT THIS MANUAL IS USED TO CALL ATTENTION TO INSTRUCTIONS INVOLVING YOUR PERSONAL SAFETY AND THE SAFETY OF OTHERS. FAILURE TO FOLLOW THESE INSTRUCTIONS CAN RESULT IN INJURY OR DEATH.



THIS SYMBOL MEANS

- **ATTENTION!**
- **BECOME ALERT!**
- **YOUR SAFETY IS INVOLVED!**

SIGNAL WORDS:

Note the use of the signal words DANGER, WARNING, and CAUTION with the safety messages. The appropriate signal word for each has been selected using the following guidelines:

DANGER: Indicates an imminently hazardous situation that, if not avoided, will result in death or serious injury.

WARNING: Indicates a potentially hazardous situation that, if not avoided, could result in death or serious injury.

CAUTION: Indicates a potentially hazardous situation that, if not avoided, may result in minor or moderate injury.

CONTACT INFORMATION

If you have questions not answered in this manual, require additional copies, or the manual is damaged, please contact your local dealer or:

McFarlane Mfg. Co., Inc.
1330 Dallas Street
P.O. Box 100
Sauk City, WI 53583

PHONE: (608) 643-3321
TOLL FREE: (800) 627-8569
FAX: (608) 643-3976
INTERNET: www.flexharrow.com
EMAIL: info@flexharrow.com



SAFETY FIRST!



Equipment Safety Guidelines

Safety of the operator is one of the main concerns in designing and developing a new piece of equipment. Designers and manufacturers build in as many safety features as possible. However, every year many accidents occur which could have been avoided by a few seconds of thought and a more careful approach to handling equipment. You, the operator, can avoid many accidents by observing the following precautions. To avoid personal injury, study the following precautions and insist that those working with you, or for you, follow them.

Replace any CAUTION, WARNING, DANGER, or instruction safety decal that is not readable or missing.

Do not attempt to operate this equipment under the influence of drugs or alcohol.

Review the safety instructions with all users annually.

This equipment is dangerous to children and persons unfamiliar with its operation. The operator should be a responsible adult familiar with farm machinery and trained in this equipment's operations. **Do not allow persons to operate or assemble this unit until they have read this manual and have developed a thorough understanding of the safety precautions and of how it works.**

To prevent injury, use a tractor equipped with a Roll Over Protective System (ROPS). Do not paint over, remove, or deface any safety signs or warning decals on your equipment. Observe all safety signs and practice the instructions on them.

Never exceed the limits of the transport cart or the harrows. If their ability to do a job, or to do so safely, is in question - **DO NOT TRY IT.**



Lighting and Marking

It is the responsibility of the customer to know the lighting and marking requirements of the local highway authorities and to install and maintain the equipment to provide compliance with the regulations. Add extra lights when transporting at night or during periods of limited visibility.

Lighting kits are available from your dealer.



Safety Sign Care

- Keep safety signs clean and legible at all times.
- Replace safety signs that are missing or have become illegible.
- Replacement parts that display a safety sign should display the same sign.
- Safety signs are available from your Distributor, Dealer Parts Department, or the factory.

How to Install Safety Signs:

- Be sure that the installation area is clean and dry.
- Decide on the exact position before you remove the backing paper.



Tire Safety

- Failure to follow proper procedures when mounting a tire on a wheel or rim can produce an explosion which may result in serious injury or death.
- Do not attempt to mount tires unless you have the proper equipment and experience to do the job.
- Inflating or servicing tires can be dangerous. Whenever possible, trained personnel should be called to service and/or mount tires.
- Always order and install tires and wheels with appropriate capacity to meet or exceed the weight of the unit. Be sure to inflate tires to tire manufacturer's specifications
- Tires that are provided by the manufacturer are designed for speeds LESS THAN 20mph. Do Not exceed or tire failure will occur.



Remember:

Your best assurance against accidents is a careful and responsible operator. If there is any portion of this manual or function you do not understand, contact your local authorized dealer or the manufacturer.



Before Operation:

- Carefully study and understand this manual.
- Do not wear loose fitting clothing which may catch in moving parts.
- Always wear protective clothing and substantial shoes.
- It is recommended that suitable protective hearing and (eye protection) sight protectors be worn.
- Keep wheel lug nuts or bolts tightened.
- Assure that the tires are inflated evenly.
- Give the unit a visual inspection for any loose bolts, worn parts, or cracked welds, and make necessary repairs. Follow the maintenance safety instructions included in this manual.
- Before using the hydraulics on the cart, be sure all fittings and connections are tight.
- Be sure that there are no tools lying on the unit.
- Make sure that the area is clear of children, animals, and other obstacles before using.
- Don't hurry the learning process or take the unit for granted. Ease into it and become familiar with your new equipment. Practice operation of your new unit. Completely familiarize yourself and other operators with its operation before using.

- Securely attach to towing unit. Use a high strength, appropriately sized hitch pin with a mechanical retainer and attach safety chain.
- Do not allow anyone to stand between the tongue or hitch and the towing vehicle when backing up to the equipment.



During Operation:

- **SAFETY CHAIN** - If equipment is going to be transported on a public highway, a safety chain should be obtained and installed. Always follow state and local regulations regarding a safety chain when towing farm equipment on a public highway. Be sure to check with local law enforcement agencies for your own particular regulations. Only a safety chain (not an elastic or nylon/plastic tow strap) should be used to retain the connection between the towing and towed machines in the event of separation of the primary attaching system.
- Install the safety chain by crossing the chains under the tongue and secure to the draw bar cage or hitch or bumper frame.
- Beware of bystanders, **particularly children!** Always look around to make sure that it is safe to start the engine of the towing vehicle or move the unit. This is particularly important with higher noise levels and quiet cabs, as you may not hear people shouting.
- **NO PASSENGERS ALLOWED** - Do not carry passengers anywhere on, or in, the tractor or equipment, except as required for operation.
- Keep hands and clothing clear of moving parts.
- Do not clean, lubricate, or adjust your equipment while it is moving.
- When altering operation, even periodically, set the tractor or towing vehicle brakes, shut off the engine, and **remove the ignition key.**
- Do not operate the hydraulic cylinders without the flow restrictors installed; the free falling harrow sections may cause serious injury.
- Pick the levellest possible route when transporting across fields. Avoid the edges of ditches or gullies and steep hillsides.
- Periodically clear the equipment of brush, twigs, or other materials to prevent buildup of dry combustible materials.
- Maneuver the tractor or towing vehicle at safe speeds.
- Avoid overhead wires or other obstacles. Contact with overhead lines could cause serious injury or death.
- Allow for unit length when making turns.
- Do not walk or work under raised wings unless securely positioned in wing rests.
- Keep all bystanders, pets, and livestock clear of the work area, particularly when raising or lowering harrow sections.
- Operate the towing vehicle from the operator's seat only.
- As a precaution, always recheck the hardware on equipment periodically. Correct all problems. Follow the maintenance safety procedures.



Following Operation:

- When disconnecting, stop the tractor or towing vehicle, set the brakes, secure the wings in the wing rests, relieve hydraulic fluid pressure, shut off the engine and **remove the ignition keys**. Make sure all jack and support stands are in place before removing hitch pins.
- Store the unit in an area away from human activity on a hard level surface.
- Do not park equipment where it will be exposed to livestock for long periods of time. Damage and livestock injury could result.
- Do not permit children to play on or around the stored unit.



Highway and Transport Operations:

- Make sure all transport lock provisions are in place and jack/parking stands are in their storage position before transporting the unit.
- Adopt safe driving practices:
 - Keep the brake pedals latched together at all times. **NEVER USE INDEPENDENT BRAKING WITH MACHINE IN TOW AS LOSS OF CONTROL AND/OR UPSET OF UNIT MAY RESULT.**
 - Always drive at a safe speed relative to local conditions and ensure that your speed is low enough for an emergency stop to be safe and secure. Keep speed to a minimum.
 - Reduce speed prior to turns to avoid the risk of overturning.
 - Avoid sudden uphill turns on steep slopes.
 - Always keep the tractor or towing vehicle in gear to provide engine braking when going downhill. Do not coast.
 - Do not drink and drive!
- Comply with state and local laws governing highway safety and movement of farm machinery on public roads.
- Use approved accessory lighting flags and necessary warning devices to protect operators of other vehicles on the highway during daylight and nighttime transport. Various safety lights and devices are available from your dealer.
- The use of flashing amber lights is acceptable in most localities. However, some localities prohibit their use. Local laws should be checked for all highway lighting and marking requirements.
- When driving the tractor and equipment on the road or highway under 20 mph at night or driving during the day, use flashing amber warning lights and a slow moving vehicle (SMV) identification emblem.
- Remember, tires supplied by the manufacturer are designed to operate LESS THAN 20mph. Do Not exceed or tire failure will occur.
- Be a safe and courteous driver. Always yield to oncoming traffic in all situations, including narrow bridges, intersections, etc. Plan your route to avoid heavy traffic.

- Be observant of bridge loading ratings. Do not cross bridges rated lower than the gross weight at which you are operating.
- Watch for obstructions overhead and to the side while transporting.
- Always operate equipment in a position to provide maximum visibility at all times. Make allowances for increased length and weight of the equipment when making turns, stopping, etc.



Performing Maintenance:

- Good maintenance is your responsibility. Poor maintenance is an invitation to trouble.
- Before working on this machine, stop the tractor or towing vehicle, set the brakes, lower into field position, relieve the hydraulic fluid pressure, shut off the engine and **remove the ignition keys**.
- **Always** use safety support and block the wheels. When performing maintenance, never use a jack to support the machine. Assist the jack with blocks or other adequate support.
- Use extreme caution when making adjustments.
- When disconnecting hydraulic lines, shut off hydraulic supply and relieve all pressure.
- Never use hands to locate a hydraulic leak on attachments. Use a piece of cardboard or wood. Hydraulic fluid escaping under pressure can penetrate the skin.
- Openings in the skin and minor cuts are susceptible to infection from hydraulic fluid. **If injured by escaping hydraulic fluid, see a doctor at once. Gangrene can result. Without immediate medical treatment, serious infection and reactions can occur.**
- When installing, replacing, or repairing hydraulic system cylinders or parts, make sure that the entire system is charged and free of air before resuming operations. Failure to bleed the system of all air can result in improper machine operation, causing severe injury.
- After servicing, be sure all tools, parts, and service equipment are removed.
- Never replace hex bolts with less than grade five bolts unless otherwise specified.
- Where replacement parts are necessary for periodic maintenance and servicing, genuine factory replacement parts must be used to restore your equipment to original specifications. The manufacturer will not claim responsibility for damages as a result of the use of unapproved parts and/or accessories.
- If equipment has been altered in any way from original design, the manufacturer does not accept any liability for injury or warranty.

MAINTENANCE AND SERVICE SCHEDULE

- Prior to each use, check for loose bolts and replace lost or worn parts.
- Grease hinge pins before each use when necessary.
Note: Clean grease fittings and replace those that are broken or missing.
- Inspect and repack wheel bearings at the beginning of each year.
- Remove dirt and debris from the harrow sections before storage.
- Parts diagrams and listings for service and repair references may be found in appendix B.

OPERATING SUGGESTIONS

There are some important points to remember in order to obtain the best possible results from your McFarlane harrow.

- To maximize the harrow's performance, it should be towed at speeds ranging from six to nine (6 - 9) mph. This keeps the field debris moving through the harrow sections and avoids clogging. The best results will be obtained after the paint has been scoured from the teeth.
- Choose the angle of attack of the harrow teeth based on field conditions. For more information see the section titled Angle of Attack.
- Getting the unit ready for transport includes the following steps:
 1. Rotate the harrow sections up.
 2. Swing the wings forward and lock them into the wing rests.
- Getting the unit ready for field use includes the following steps:
 1. Unlock the wings from the wing rests and swing the wings out.
 2. Rotate the harrow sections down.
- If the wing cables are not tight, adjust the attachment point to the Main Frame to tighten them. Follow the instructions in the section titled Attach the Wing Cables.

ASSEMBLY SUGGESTIONS

- You will find the machine is easier to assemble if the set-up instructions are followed in the order given in the manual.
- Before beginning, sort the various bolt bags, hardware bags and hydraulic bags according to what part of the unit that is being setup. Refer to the end of the parts listing in appendix B. Only open the bag or bags that are required as the setup instructions are followed.
- Whenever the terms “left” and “right” are used, it should be understood to mean when standing behind and facing the unit. This is also known as the “driver’s left” and the “driver’s right.”
- The term “field position” refers to the position the harrows are in when the unit is being used in the field - that is, with the wings out and the harrow sections down.
- The term “transport position” refers to the position the harrows would be in when the unit is being transported from place to place - that is, with the harrows up and the wings folded and secured in the wing rests.
- When assembling this unit, make sure that the parts are securely held before proceeding to the next step.
- Bolt torque specifications are given in appendix A.
- The hydraulic cylinder and hose requirements are listed in the parts listing in appendix B. It is not recommended that other size cylinders or hoses be substituted. Hoses are marked with the part number near the ends. The last three digits indicate the hose length in inches. Fittings with a restrictor are marked with an ‘R’.
- A dual acting hydraulics supply is required. The unit is designed for the standard ASAE pressure of 1500 psi.
- Tire requirements are also listed in the parts listing in appendix B.
- Layout diagrams for each unit may be found in appendix C. Mark the page with the diagram that refers to your unit, it will be referred to periodically throughout the manual.

STEP - BY - STEP ASSEMBLY INSTRUCTIONS

Main Frame Assembly

1. Bolt the Hitch Tube to the Main Frame using 1 x 8 bolts and lock nuts. Note that there are different positions for the Hitch Tube.
2. Insert the Hub and Spindle into the Main Frame and secure using $\frac{1}{2}$ x 3 $\frac{1}{2}$ bolts and lock nuts. Install the 11L tires.
3. Attach the jack to the front of the Main Frame.

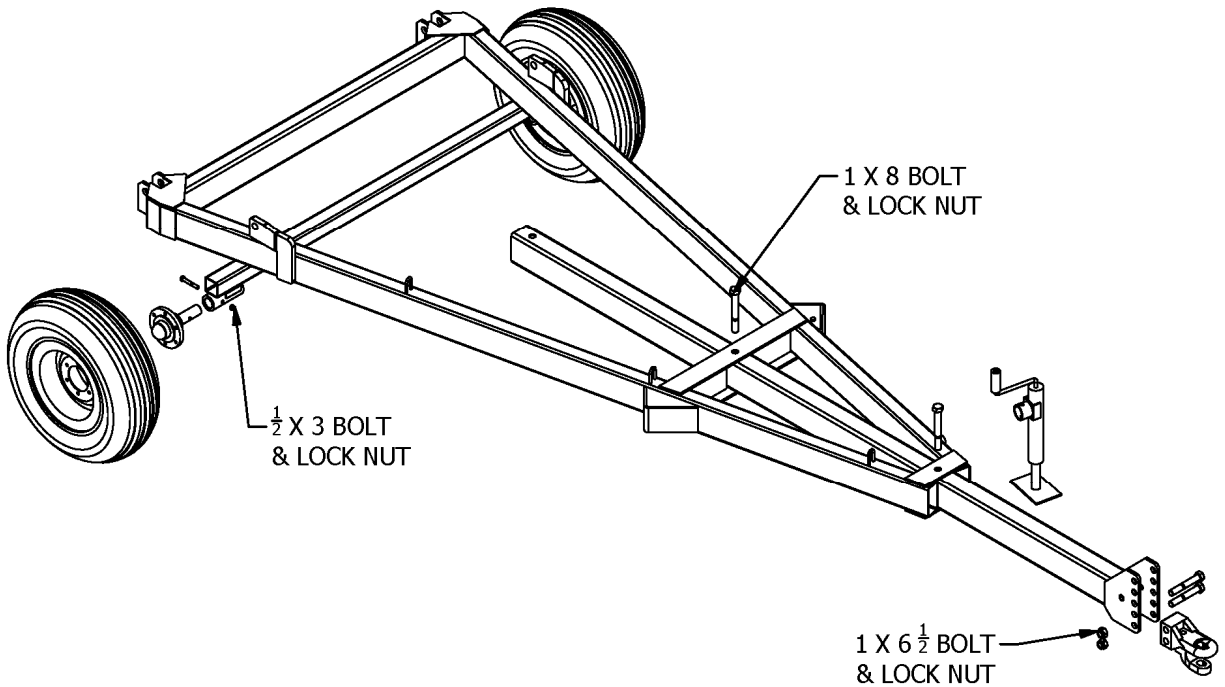

Figure 1

4. Assemble either a clevis hitch (figure 2) or a pintle hitch (figure 3) as required by the tractor or towing vehicle. Note the opposite orientation of the base hitch for each hitch type. Attach the hitch assembly to the Main Frame with two 1" x 6 $\frac{1}{2}$ " bolts and locking nuts.

Note: Parts have been provided to assemble a clevis hitch or a pintle hitch. Not all the included parts will be needed to assemble either type of hitch. Be sure to store the extra parts in a safe place; they will be needed if one requires the use of the other hitch type.

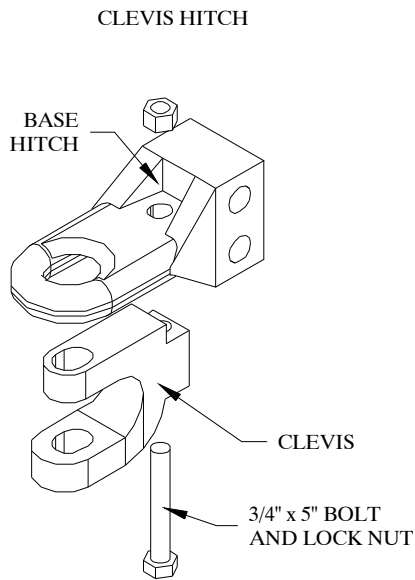

Figure 2

OR

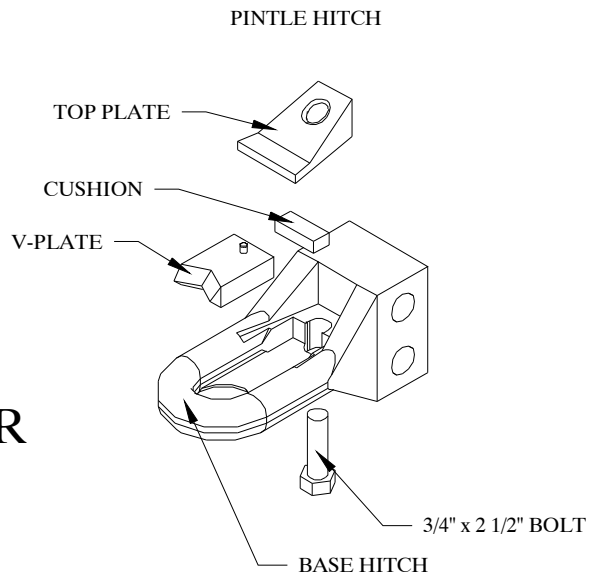

Figure 3

Attach the Center Bar

1. Attach the Center Bar to the Main Frame using 1 1/4 x 5 1/2 bolts and nylon jam nuts. Install the 4 x 8 cylinders as shown.

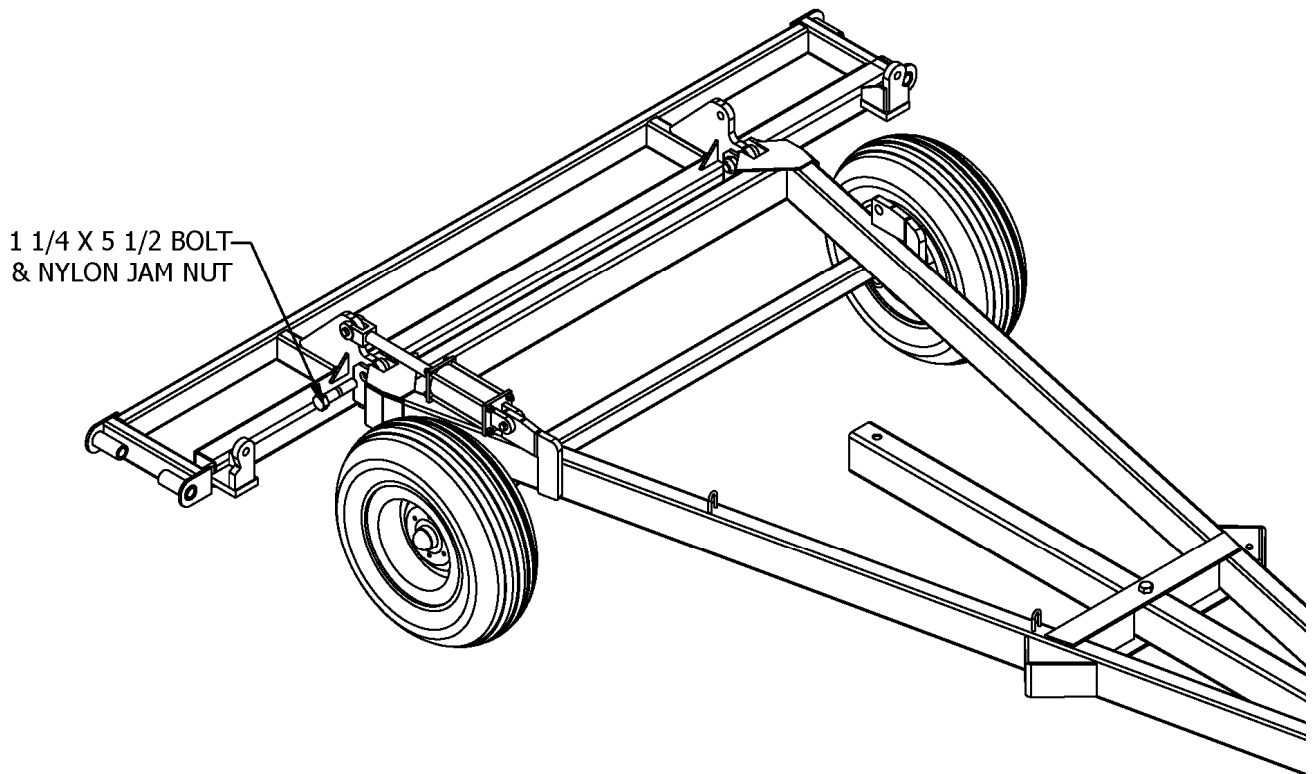

Figure 4

Attach and Assemble the Wing Frame

1. Attach the Wing Frame to the Center Bar using the 1 ¼ Hinge Pins and ½ x 3 bolts and lock nuts.
2. Insert a Hub and Spindle into the tube on the end of the Wing and secure using a ½ x 3 ½ bolt and lock nut. Install the 9.5L tires.
3. Attach the 14” cylinders between the Center Bar and Wing Frame, making sure the ports face towards the front of the unit.

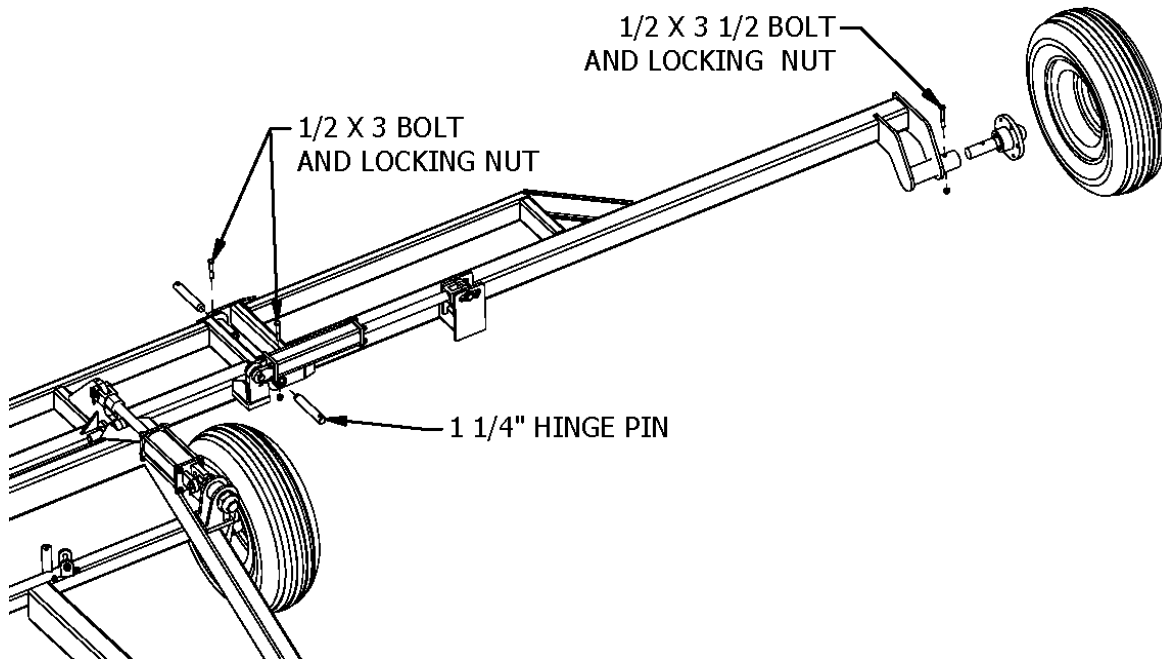

Figure 5

Install the Hydraulics System

Refer to the hydraulic system diagram in appendix B for details. For each step, refer to the diagrams for correct orientation.

1. Insert a male tee (o-ring fitting in center position) into both adapters on the 4 x 8 cylinders on the right side of the Main Frame. Insert a tee (one female position) into both of the tees just installed.
2. Insert a male tee (o-ring fitting in side position) into both adapters on the 4 x 8 main lift cylinders on the left side of the unit.
3. Insert a male elbow (with restrictor) into both ports of each 14” wing fold cylinders.
4. Attach two 57” hoses from both ports on one 4 x 8 cylinder to the other one.
5. Attach two 80” hoses from the base end of the 4 x 8 cylinders to the base end of the 14” wing fold cylinders.
6. Attach two 90” hoses from the rod end of the 4 x 8 cylinders to the rod end of the 14” wing fold cylinders.

7. Attach the 265" to the rod end of the 4 x 8 cylinder on the right hand side of the unit. Attach the 276" hose to the base end and then run both hoses to the hitch.
8. Secure all hoses to the frame to prevent damage between moving parts or from contacting the ground.

Attach the Lift Arms

1. Refer to the appropriate layout diagram in appendix C. Note the dimensions for the lift arm locations. Center a lift arm on each of these marks and secure using 1/2 x 7 1/2 bolts and lock nut.
2. Bolt a 8-link pull chain to the front pull point using a 1/2 x 1 3/4 bolt and lock nut. For the rear Lift Chain, the square washer goes between the bolt head and the 5-link chain, there is also a flat washer under the locking nut.
3. Secure the 1/2 x 3 eye-bolt to the middle hole on the Lift Arm rear lift bracket by placing a 1/2" nut on either side of the bracket. Do not tighten yet.
4. Attach the Brace Angle to the Lift Arm using the 7/16 x 1 1/2 Bolts, Flat Washers and Locking Nuts.

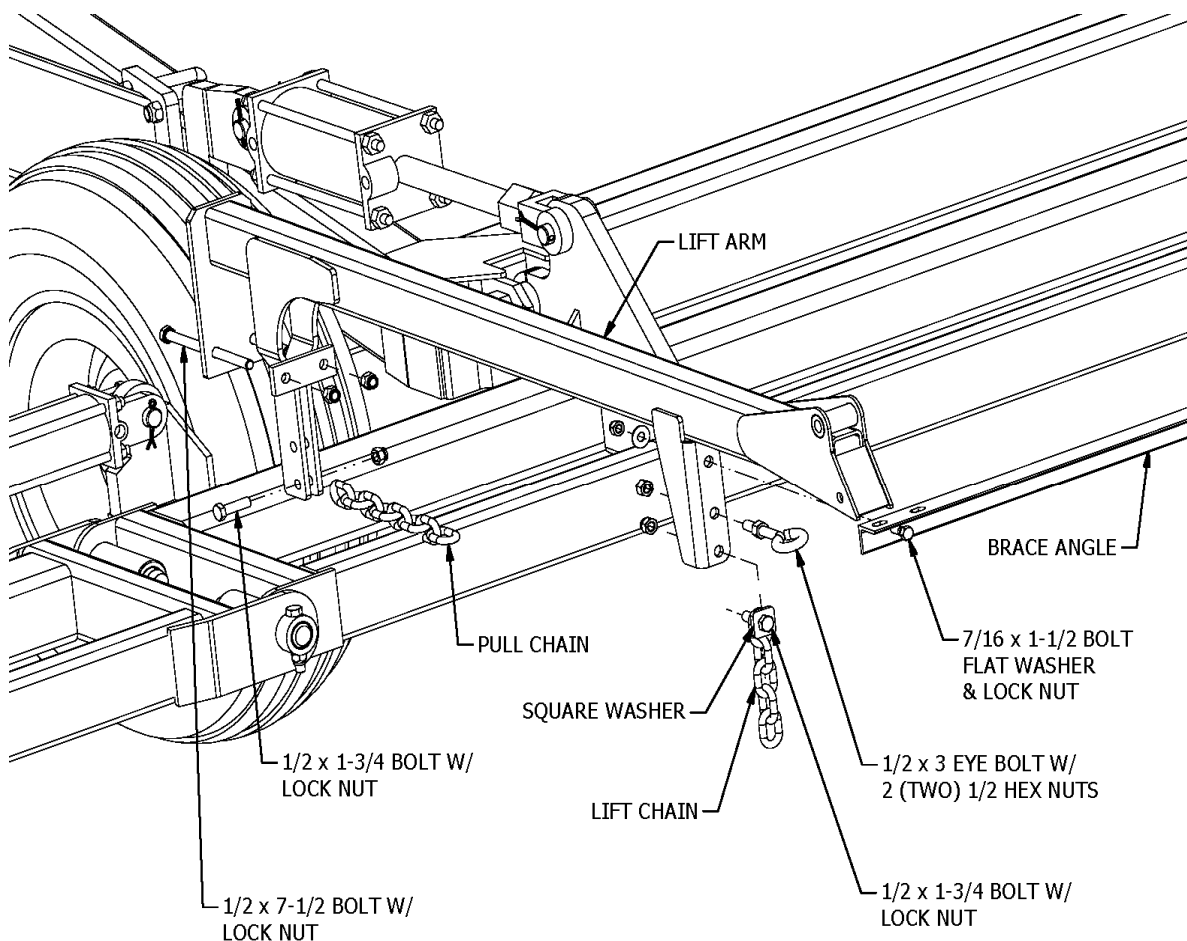

Figure 6

Attach the Swing Arm and Pivot Bracket

1. Attach the Tension Spring to the Eye Bolt and Swing Arm using the Lock Clips, 7/16 x 1 1/2 bolts with locking nuts, one link chain and 1/2 x 1 3/4 bolt and locking nut.
2. Attach the Swing Arm to the Lift Arm using the 5/8 x 4 bolt and locking nut.
3. Attach the Pivot Bracket to the Swing Arm using the 5/8 x 5 bolt and locking nut. Insert the 1/2 x 4 1/2 bolt through the angle iron on the Swing Arm and secure with the locking nut.

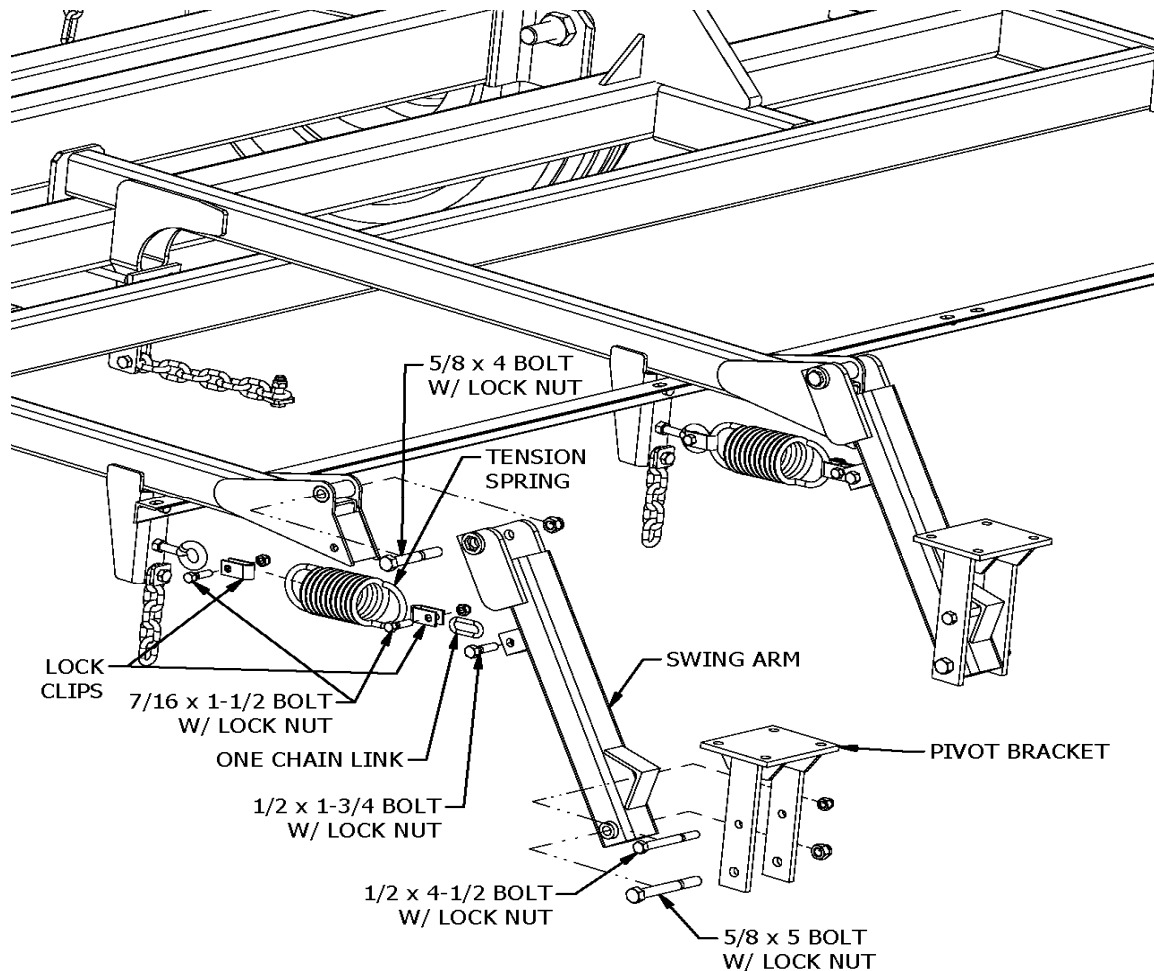

FIGURE 7

Harrow Section Identification

Harrow section identification is quite simple, the first two letters (FA) indicates the harrow type. The next number (500, 600, etc.) tells the number of teeth per bar (500 = 5 teeth per bar, etc.).

Angle of Attack

Before placing the harrows into their appropriate places, determine the angle of attack desired. The angle of attack can be changed by simply reversing the harrow sections and pulling them from the opposite end. The steeper the angle of attach, the more aggressive the harrowing will be. It is recommended the least aggressive angle is used with the pull hook in the top position as shown.

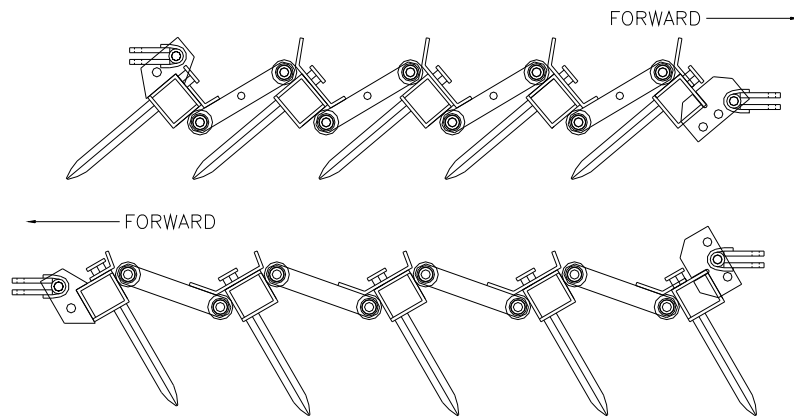

Figure 7

Connect the Harrow Section

1. Bolt the pull chains to the front tabs on the front harrow sections. Use 1/2 x 1 3/4 bolts, square washers and lock nuts. The chains should be bolted to the bottom of the pull tabs.
2. Bolt the lift chains to the rear pull tabs.

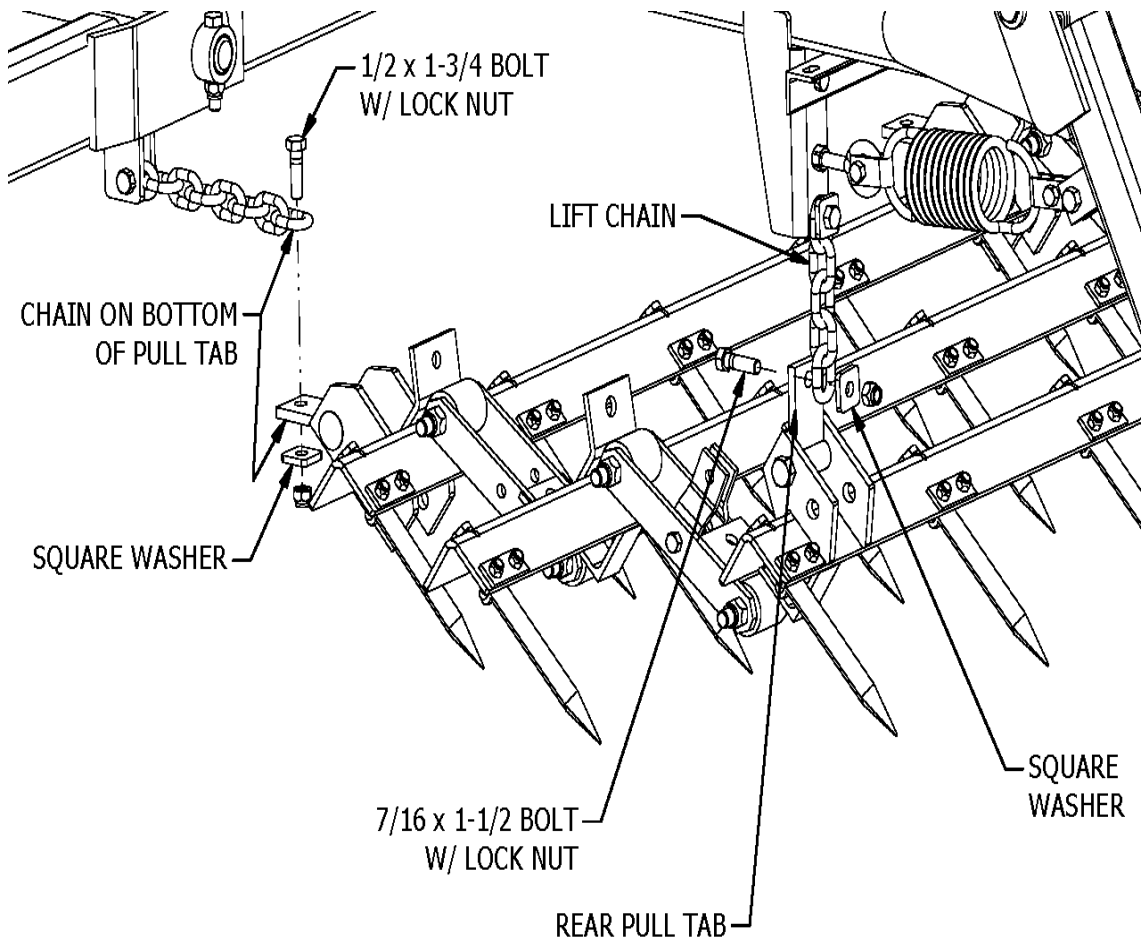

Figure 8

Attach the Rolling Basket

1. Refer to the appropriate layout diagram in appendix C. Note the dimensions for the rolling basket locations.
2. Bolt the Rolling Basket to the Swing Arm Bracket using 1/2 x 3 x 4 U-bolts and lock nuts. Start with the Baskets centered on the two Lift Arms. Do not tighten yet.
3. After all Rolling Baskets have been attached, make any adjustments side-to-side to ensure total coverage. Tighten all bolts.

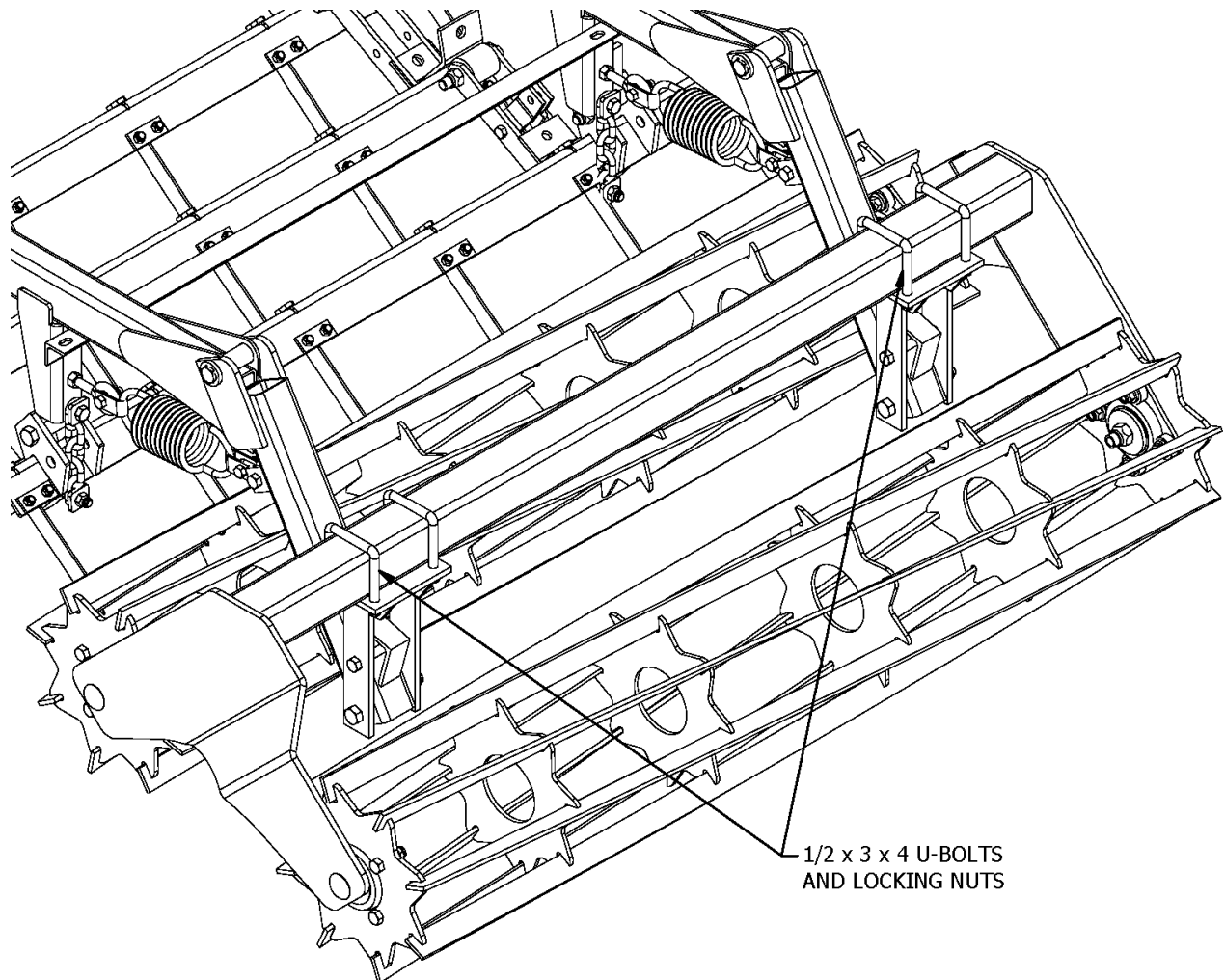

Figure 9

For the next steps you will need enough room to lower both wings completely. **Be sure the unit is attached to a tractor of adequate size before actuating the hydraulics!**

Attach the Wing Cables

1. Open both wings so that they are straight out and in line with the center bar. Rotate the harrow sections down into the field position.
2. Attach one end of the Wing Cable to the plate on the Wing with a large shackle.
3. Attach the other end to the 5/8 x 5 eye-bolt with a large shackle. Secure the eye-bolt to the bracket on the Main Frame with lock nuts. Tighten the wing cable.

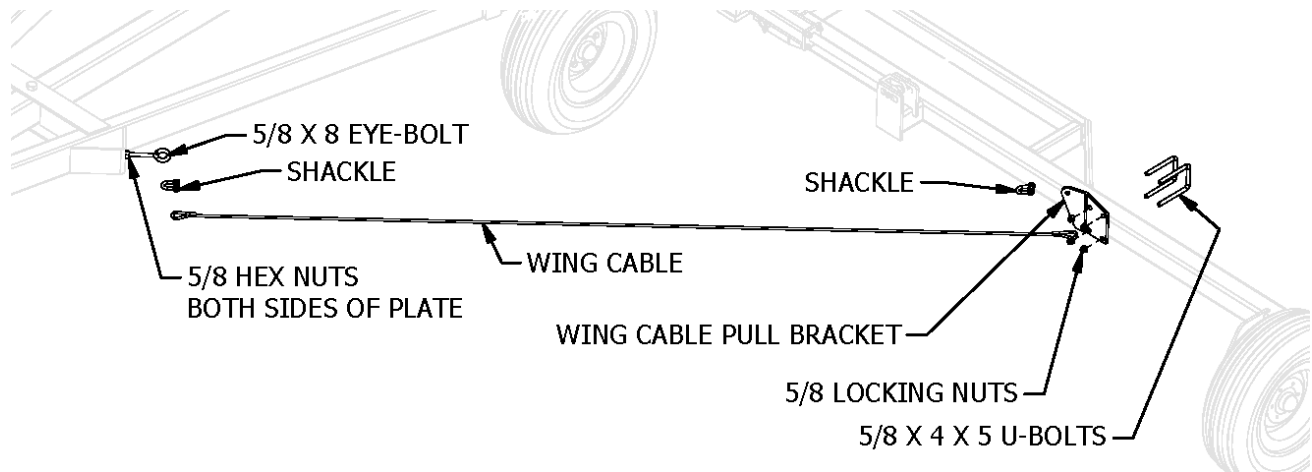

Figure 11

Attach the Wing Cable Lift Assembly

1. Bolt the Cable Lift Bracket to the Main Frame approximately 24" from the front of the frame side tube. Use two 1/2 x 3 x 7 U-bolts and lock nuts. Do *not* tighten yet.
2. Bolt the Cable Lift Angle to the Cable Lift Bracket. Use the 5/8 x 4 bolt and lock nut.
3. Attach the Cable Lift Spring to the tabs on the Cable Lift Bracket and the Cable Lift Angle by placing a lock clip on each end of the spring. Use 7/16 x 1 1/2 bolts and lock nuts to fasten the lock clips and spring to the tabs.
4. Attach the 1/4 x 6-link lift chain to the Cable Lift Angle with a small shackle.
5. Adjust the assembly so that the chain on the Cable Lift Angle hangs directly above the cable when the cart is in the field position and the cable is pulled tight.
6. Using a small shackle, attach the lift chain to the Wing Cable.
7. Rotate the wings into the transport position. If the cables are touching the ground, the cable lift bracket assembly needs to be moved until the cable is clear of the ground. When properly adjusted, tighten all bolts.

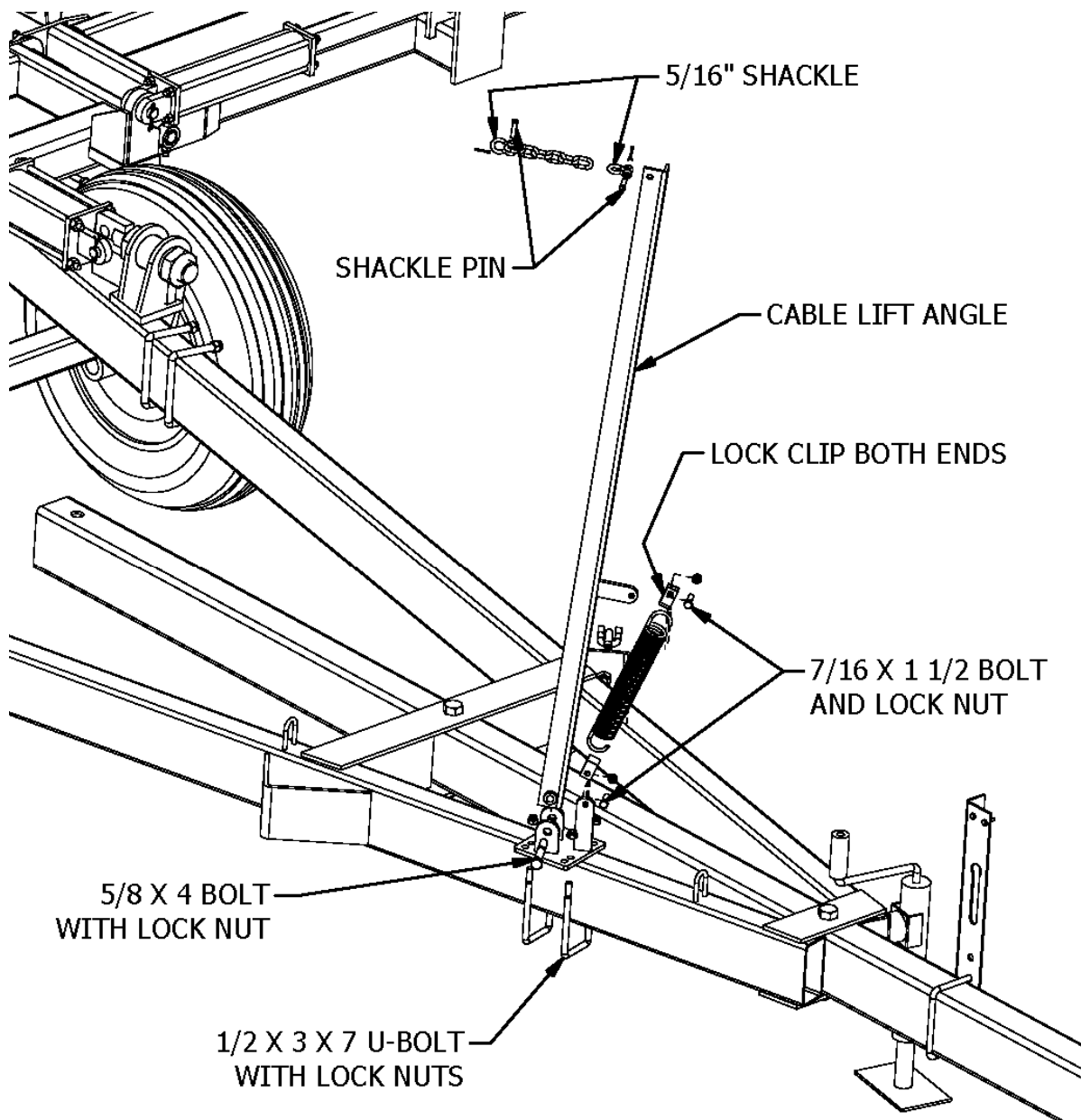

Figure 12

Attach the Wing Rests

1. Place the Wing Rests approximately 18" ahead of the cylinder post on the Main Frame. Bolt firmly in place using the 5/8 x 6 x 4 U-bolts and lock nuts. Do *not* tighten yet.

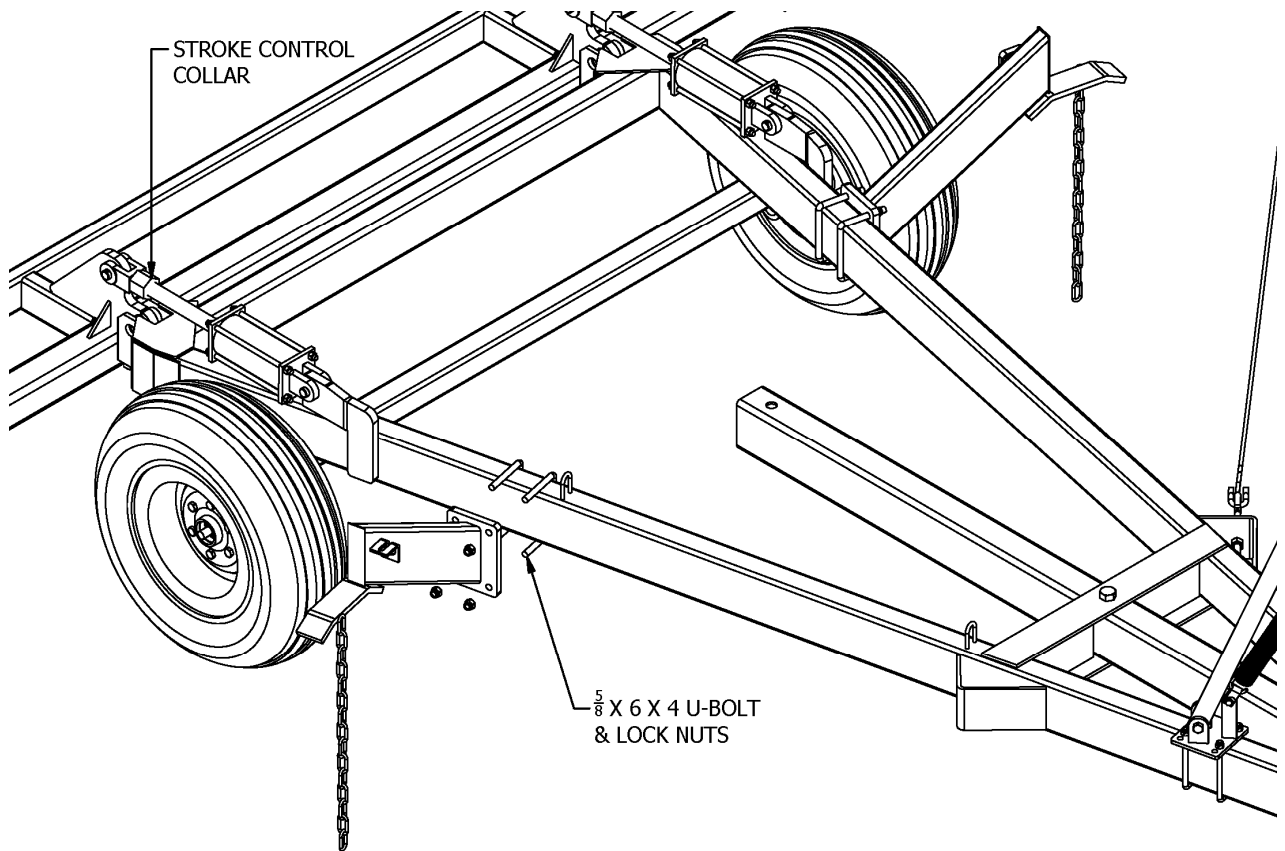

Figure 13

Final Adjustments

1. Unfold the unit into the field position and fully extend all cylinders.
2. Slowly fold the unit into the transport position. Be sure the Wing Frames engage the ramp on the Wing Rest and fully sit on it. It may be necessary to adjust the Wing Rest back/forward. It may also be necessary to adjust the stroke control collar on the 4x8 main lift cylinders. If the wings are too low, extend the collar until the wings engage the Wing Rest ramp.
3. Unfold the unit into field position and pull the completed unit ahead a few feet to check that everything is properly assembled and that nothing is binding or misaligned. Check to make sure that all fasteners are tight.
4. Be sure to wrap the chains around the wing tubes for security during transport.
5. With the unit in the transport position, attach the red and amber reflectors at the widest visible points. The red reflectors should be visible from the rear of the unit, and the amber reflectors should be visible from the front of the unit.
6. Do not detach the unit from the tractor unless the jack stand is down and the wings are secured in the wing rests.
7. After the first few hours of operation, check all fasteners and tighten if necessary. Include wheel lugs.

This completes the assembly of your harrow and transport cart. Before using the unit, double check that all components have been assembled properly. If there are any questions regarding any of the assembly steps, contact your local dealer for an explanation. Do not operate this or any equipment unless you are sure that all components operate as they were designed to operate.

TROUBLESHOOTING

PROBLEM	POSSIBLE CAUSE	SOLUTION
Hydraulics actuate too rapidly	Hydraulic restrictors not installed	Install hydraulic restrictors
Wings will not slide into wing rests	Wing rests improperly positioned	Reposition wing rests
Excessive clogging during operations	Angle of attack too steep	Pull harrow sections from the other end
	Ground speed too low	Increase ground speed to 6 - 9 mph

BOLT TORQUE SPECIFICATIONS

Coarse Thread Series			Fine Thread Series		
Nut Size and Threads per Inch	Nut Tightening Torque (lb.ft.)		Nut Size and Threads per Inch	Nut Tightening Torque (lb.ft.)	
Grade C Nuts			Grade C Nuts		
	Max.	Min.		Max.	Min.
1/4 - 20	14.7	10	1/4 - 28	14.7	10
5/16 - 18	22.3	15.2	5/16 - 24	23.4	18.4
3/8 - 16	39	28	3/8 - 24	41	30
7/16 - 14	60	44	7/16 - 20	60	44
1/2 - 13	88	63	1/2 - 20	98	70
9/16 - 12	134	98	9/16 - 18	134	98
5/8 - 11	172	127	5/8 - 18	176	127
3/4 - 10	295	218	3/4 - 16	295	218
7/8 - 9	440	317	7/8 - 14	440	317
1 - 8	651	506	1 - 14	703	610

WHEEL LUG TORQUE SPECIFICATIONS

Tire Size	Lug Size	Lug Tightening Torque (lb.ft.)	
		Max.	Min.
18.5X8.5-8	½ nut	85	75
7.60-15	½ x 1	85	75
9.5L-15	½ x 1	90	80
11L-15	½ x 1	90	80
12.5L-15	9/16 x 1	90	80
13X13.5-15	9/16 x 1	90	80
425/65R 22.5	¾ nut	90	80

**RBH-232 through RBH-236 HARROW CART
PARTS DIAGRAM**

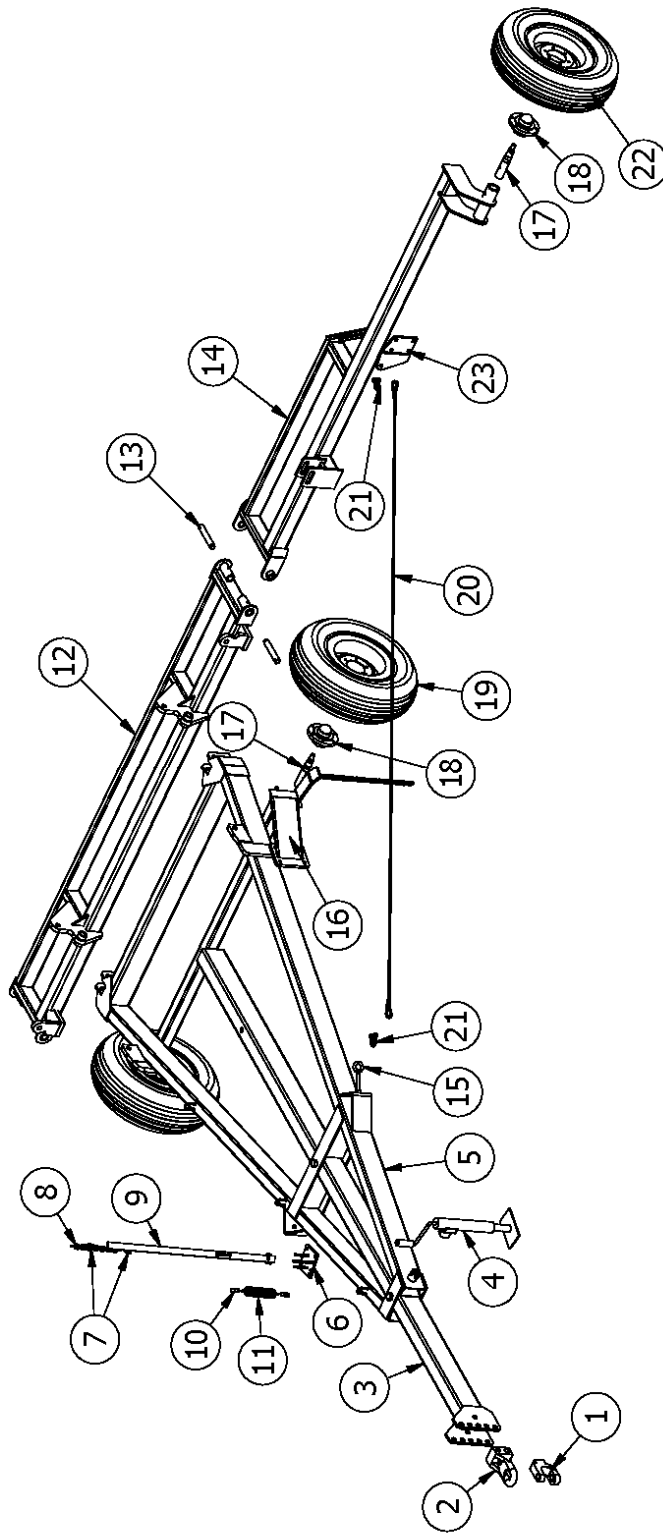

**RBH-232 through RBH-236 HARROW CART
PARTS LIST**

Always order by Part Number - *Not* by Key Number

KEY	PART #	DESCRIPTION	QTY.
1	PPI-208	CLEVIS	1
2	PPI-200	BASE HITCH	1
3	HDL-201	HITCH POLE – 12’	1
4	HD-1151	JACK STAND (10")	1
5	HDL-223	MAIN FRAME	1
6	HDL-2541	CABLE LIFT BRACKET, RT	1
**	HDL-2540	CABLE LIFT BRACKET, LT	1
7	AL-030	5/16 SHACKLE	4
8	CH-1406	¼ X 6 LINK CHAIN	2
9	HDL-2543	CABLE LIFT ANGLE, 63”	2
10	N-021	LOCK CLIP	4
11	PH-10	CABLE LIFT ARM SPRING	2
12	HDL-232	CENTER BAR	1
13	RT-2124	WING HINGE PIN – 1 ¼ X 7 ½	4
14	***	WING FRAME	2
15	EB-5808	EYE BOLT, 5/8 X 8	2
16	HDL-2522	WING REST	1
17	WDL-2505	MAIN FRAME AXLE SPINDLE	2
18	HD-1371	HUB (6-hole hub)	4
**	HD-1360	GREASE SEAL (6-hole hub)	4
**	HD-1362	INNER BEARING (6-hole hub)	4
**	HD-1361	HUB WITH RACES (6-hole hub)	4
**	HD-1363	OUTER BEARING (6-hole hub)	4
**	HD-1364	SPINDLE FLAT WASHER (6-hole hub)	4
**	HD-1365	SPINDLE HEX NUT (6-hole hub)	4
**	CP-1517	COTTER PIN	4
**	HD-1367	DUST CAP (6-hole hub)	4
19	11L	MAIN FRAME TIRE	2
	HD-1368	RIM (15" x 8" 6-hole) for 11L-15 tire	2
20	WC-8145	WING CABLE	2
21	HDL-219	WING CABLE SHACKLE, 5/16	2
22	9.5L	WING FRAME TIRE	2
	HD-1370	RIM (15" x 6" 6-hole) for 9.5L-15 tire	2
23	HDL-235	WING CABLE PULL BRACKET, LEFT	1
	HDL-236	WING CABLE PULL BRACKET, RIGHT	1
	**	Unnumbered items are not pictured.	
	***	Please specify model number when ordering these parts.	

McFarlane Manufacturing reserves the right to change specifications of design at any time without obligation to modify previous products.

LIFT ARM, DOUBLE BASKET PARTS DIAGRAM & LIST

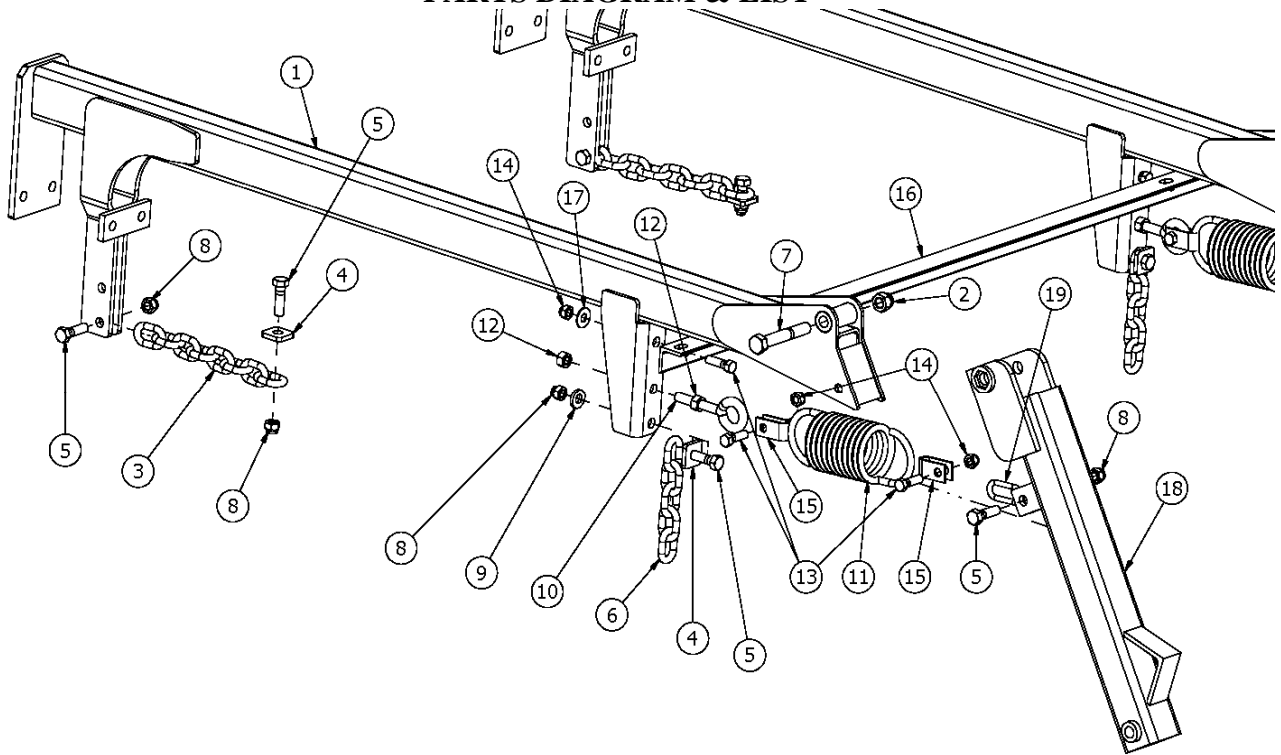

Always order by Part Number - *Not* by Key Number

KEY	PART #	DESCRIPTION
1	RBH-237	3-BAR LIFT ARM – 58”
1	RBH-234	LIFT ARM, DOUBLE BASKET ONLY – 22”
2	NLT-6311	5/8-11 TOP LOCK NUT
3	CH-0808	8 LINK CHAIN
4	HDD-016	1/2” SQUARE WASHER
5	BH-5018	1/2 X 1 3/4 GRADE 5 HEX BOLT
6	CH-0805	5 LINK CHAIN
7	BH-6340	5/8 X 4 GRADE 5 HEX BOLT
8	NLT-5013	1/2-13 TOP LOCK NUT
9	FW-005	1/2” FLAT WASHER
10	EB-1203	1/2 X 3 EYE BOLT
11	RBH-0308	3 X 8 SPRING
12	NH-5013	1/2” HEX NUT
13	BH-4415	7/16 X 1 1/2 GRADE 5 HEX BOLT
14	NLT-4414	7/16-14 TOP LOCK NUT
15	N-021	LOCK CLIP BRACE ANGLE
16	***	BRACE ANGLE
17	FW-0044	7/16 FLAT WASHER
18	RBH-217	DOUBLE BASKET PIVOT ARM ASSEMBLY
19	CH-0701	CHAIN, 7/O X 1 LINK

*** Please specify model number when ordering these parts.

DOUBLE ROLLING BASKET PARTS DIAGRAM & LIST

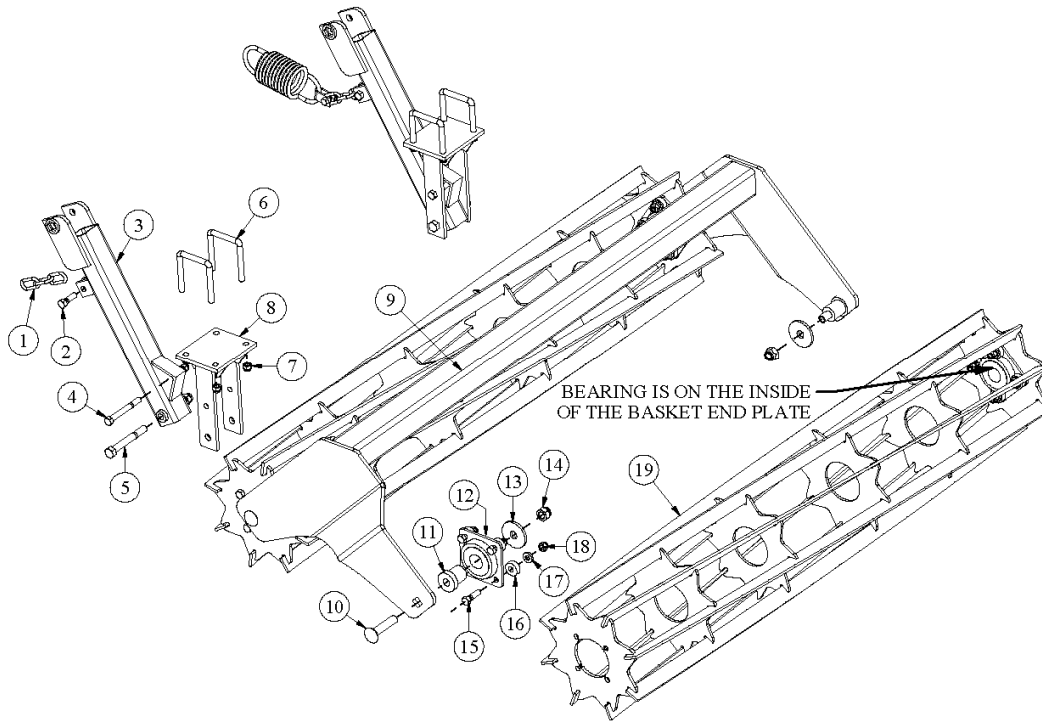

Always order by Part Number - *Not* by Key Number

KEY	PART #	DESCRIPTION
1	CH-0604	4 LINK SPRING CHAIN
2	BH-5018	1/2-13 X 1 3/4 GRADE 5 HWX BOLT
3	RBH-217	BASKET PIVOT ARM, DOUBLE
4	BH-5045	1/2-13 X 4 1/2 GRADE 5 HEX BOLT
5	BH-6350	1/2 X 3 X 4 U-BOLT
6	BU-1234	5/8 X 4 GRADE 5 HEX BOLT
7	NLT-5013	1/2-13 TOP LOCK NUT
8	DRB-3505	PIVOT BRACKET
9	***	DOUBLE BASKET MOUNT
10	BC-7540	3/4-10 X 4 CARRIAGE BOLT
11	SRB-1408	BEARING INSERT, 2 1/8
12	DRB-3826	BEARING, RIVETED, 1 1/2 ROUND
13	SRB-1406	BASKET BEARING WASHER
14	NLT-7510	3/4-10 TOP LOCK NUT
15	BH-5018	1/2-13 X 1 3/4 GRADE 5 HEX BOLT
16	DRB-3828	BASKET BEARING RUBBER WASHER
17	FW-0050	1/2 FLAT WASHER
18	NLT-5013	1/2 TOP LOCK NUT
19	***	ROLLING BASKET
***	***	Please specify model number when ordering these parts.

McFarlane Manufacturing reserves the right to change specifications of design at any time without obligation to modify previous products.

FA-3 BAR HARROW SECTIONS

INCLUDES FA-500-3, FA-600-3, FA-700-3, FA-800-3 AND FA-900-3

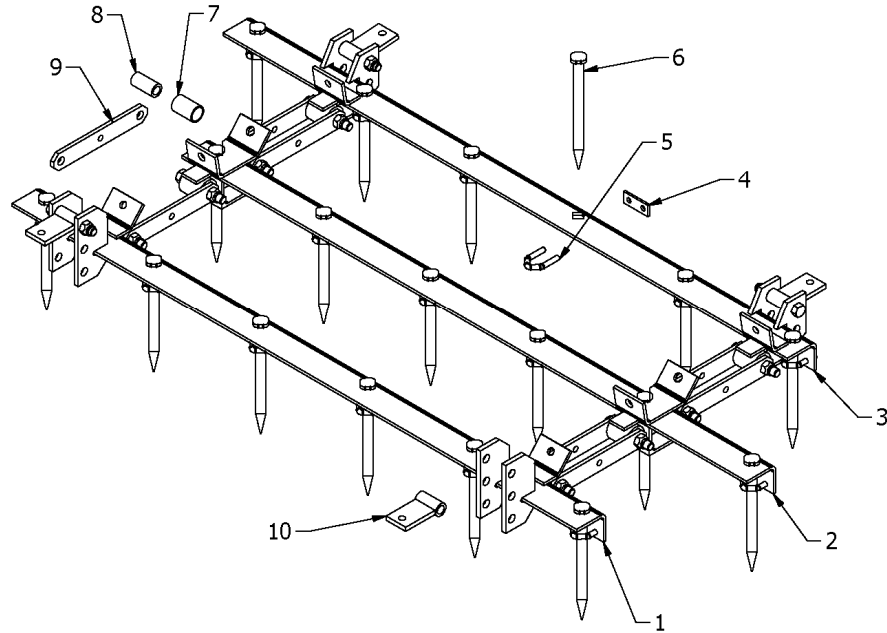

KEY	PART #	DESCRIPTION
1	FA-551	#1 HARROW BAR (FA-500-3)
1	FA-651	#1 HARROW BAR (FA-600-3)
1	FA-751	#1 HARROW BAR (FA-700-3)
1	FA-851	#1 HARROW BAR (FA-800-3)
1	FA-951	#1 HARROW BAR (FA-900-3)
2	FA-556	#2 HARROW BAR (FA-500-3)
2	FA-656	#2 HARROW BAR (FA-600-3)
2	FA-756	#2 HARROW BAR (FA-700-3)
2	FA-856	#2 HARROW BAR (FA-800-3)
2	FA-956	#2 HARROW BAR (FA-900-3)
3	FA-557	#3 HARROW BAR (FA-500-3)
3	FA-657	#3 HARROW BAR (FA-600-3)
3	FA-757	#3 HARROW BAR (FA-700-3)
3	FA-857	#3 HARROW BAR (FA-800-3)
3	FA-957	#3 HARROW BAR (FA-900-3)
4	FA-4103	3/8" V-BOLT PLATE
5	BV-3812	3/8" V-BOLT
6	CT-106	3/4" X 12" TOOTH
7	CT-107	OUTER BUSHING
8	CT-102	INNER BUSHING
9	CT-105	CONNECTOR FLAT
10	FA-4105	PULL HOOK

9/1/09

RBH-232 through 236 HARROW CART HYDRAULICS DIAGRAM & LISTING

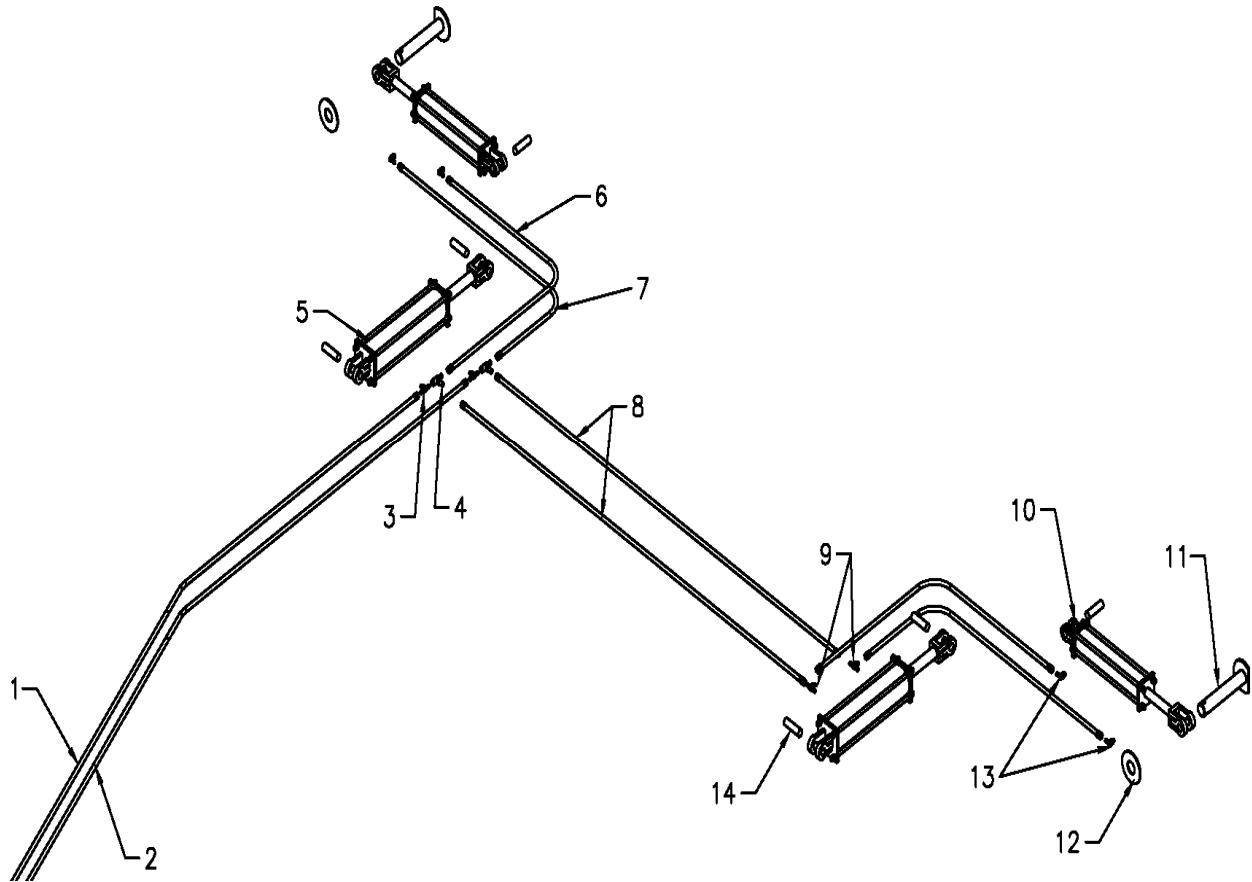

KEY	PART #	DESCRIPTION	QTY.
1	HYH-9312	3/8" X 312" HYDRAULIC HOSE with one 1/2" end	1
2	HYH-7324	3/8" X 324" HYDRAULIC HOSE with restrictor	1
3	HYF-1809	TEE (3/8"m - 1/2"o - 3/8"m)	2
4	HYF-1188	TEE (3/8"f - 3/8"m - 3/8"m)	2
5	HYA-34008	4 X 8 ASAE HYDRAULIC CYLINDER	2
6	HYH-8080	3/8" x 80" HYDRAULIC HOSE	2
7	HYH-8090	3/8" x 90" HYDRAULIC HOSE	2
8	HYH-8057	3/8" x 57" HYDRAULIC HOSE	2
9	HYF-1089	TEE (1/2"o - 3/8"m - 3/8"m)	2
10	HYC-32014	2 X 14 HYDRAULIC CYLINDER	2
11	CL-1005	1" X 5" CLEVIS PIN	2
12	FW-0010	1" FLAT WASHER	4
13	HYF-2821	ELBOW (3/8"m - 1/2"o-ring) with restrictor	4
14	HYO-2103	1" x 3 1/2" CLEVIS PIN	8

Note: When ordering replacement parts, please specify cylinder make & part number.

McFarlane Manufacturing reserves the right to change specifications of design at any time without obligation to modify previous products.

RBH-232 LAYOUT DIAGRAM

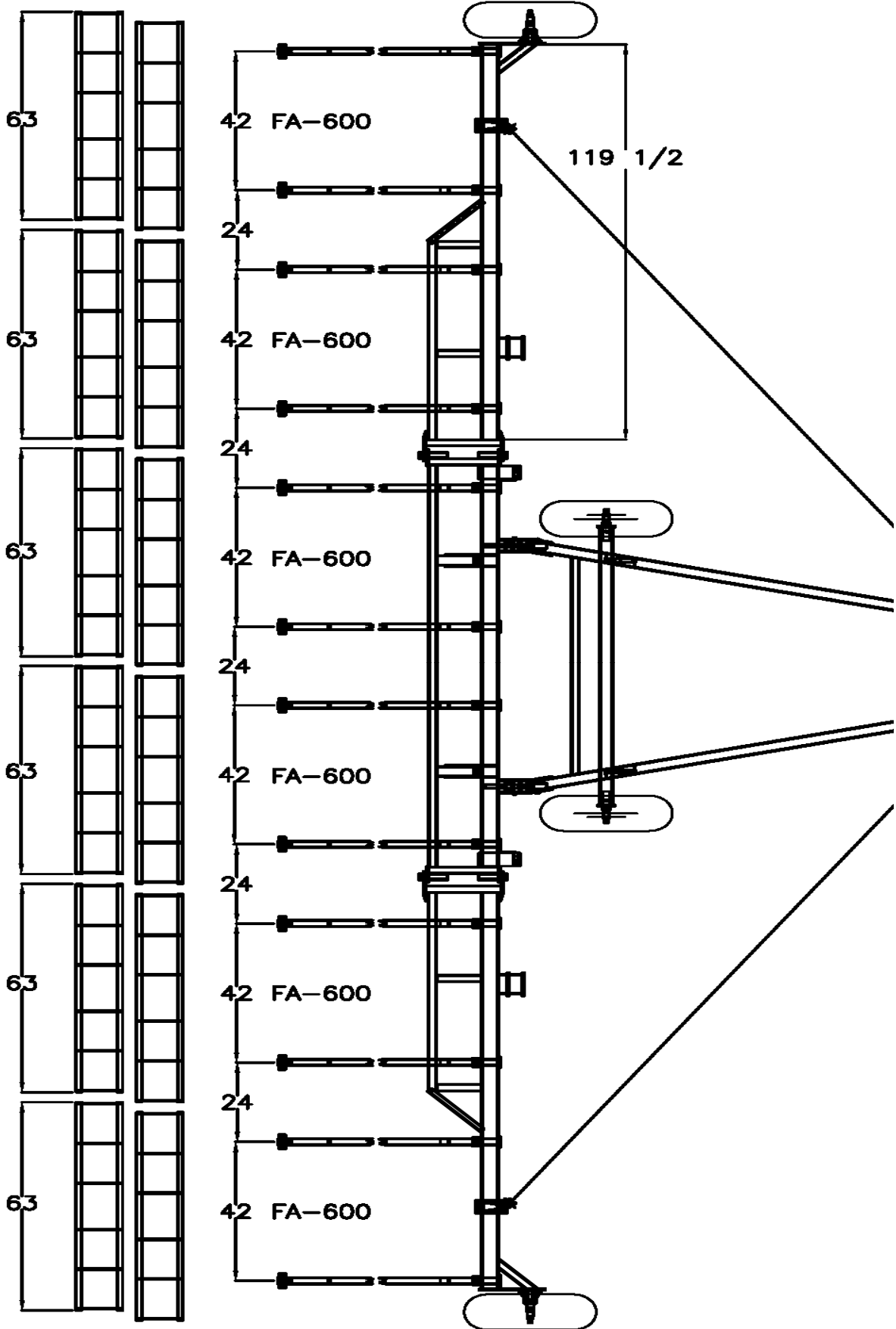

RBH-234 LAYOUT DIAGRAM

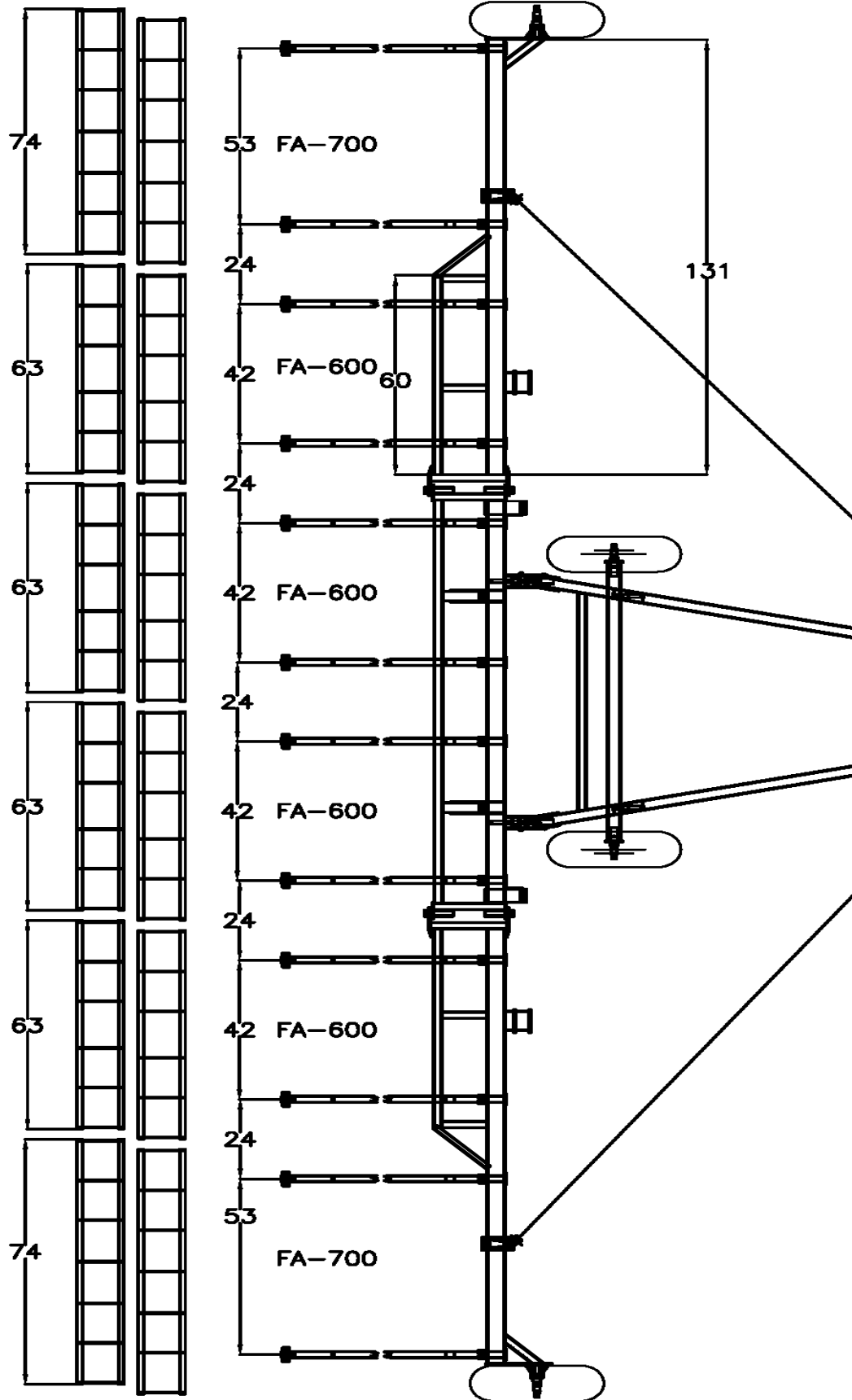

RBH-236 LAYOUT DIAGRAM

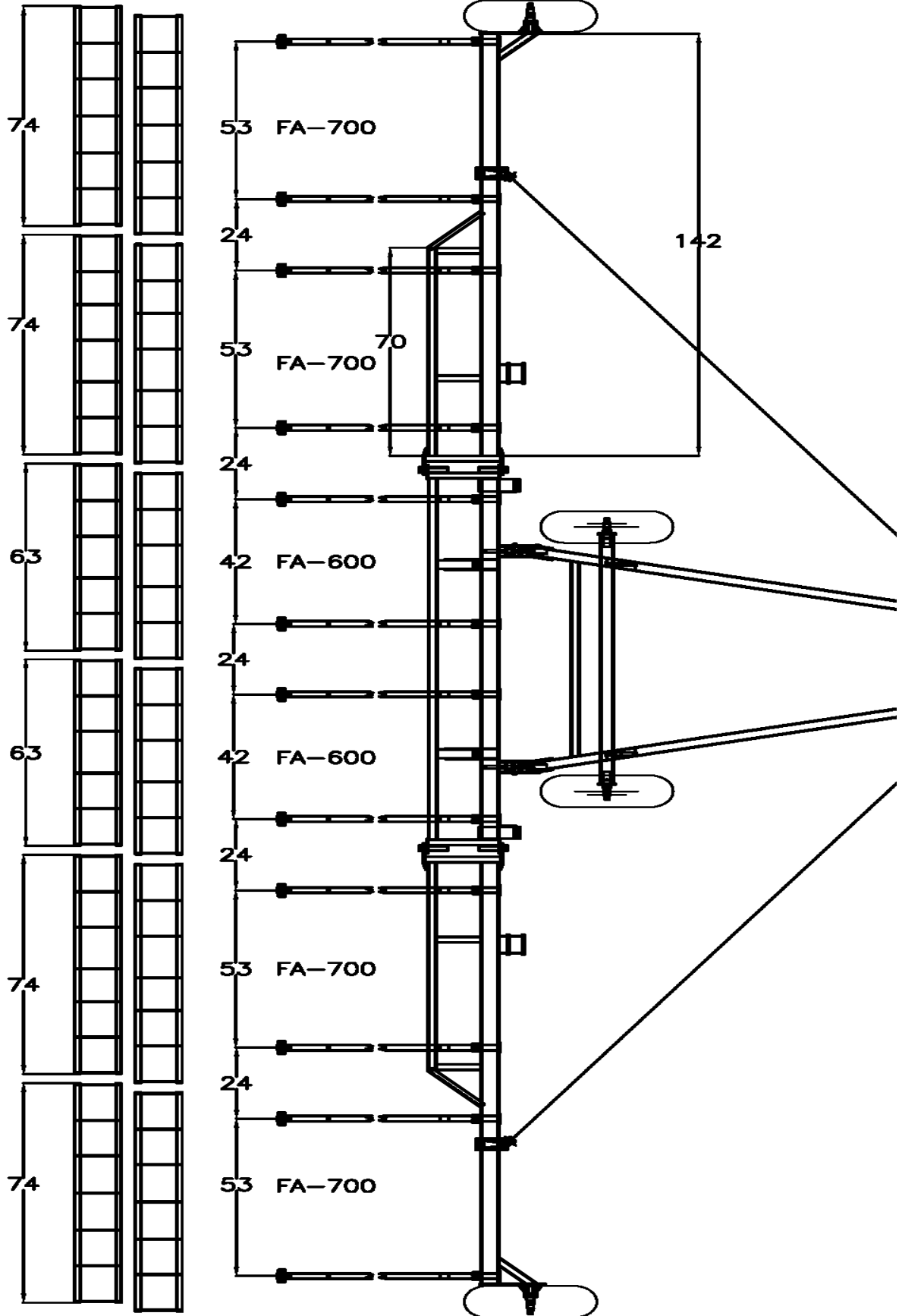

WARRANTY REGISTRATION FORM

This form must be filled out by the dealer and owner and sent to: McFarlane Mfg. Co., Inc., 1330 Dallas Street, P.O. Box 100, Sauk City, WI 53583.

WARRANTY REGISTRATION FORM & INSPECTION REPORT

WARRANTY REGISTRATION

This form must be filled out by the dealer and signed by both the dealer and customer at the time of delivery.

Customer Name _____ Dealer Name _____

Address _____ Address _____

City, state, code _____ City, state, code _____

Phone number (____) _____

Model _____ Serial Number _____ Delivery Date _____

DEALER INSPECTION REPORT

- _____ Wheel bolts tight
- _____ Fasteners tight
- _____ Hydraulic hoses free
- _____ Hydraulic fittings tight
- _____ Arms free
- _____ Check tire pressures
- _____ Lubricate machine

SAFETY

- _____ All decals installed
- _____ Review operating and safety instructions

I have thoroughly instructed the buyer on the above described equipment; review included the operator's manual content, equipment care, adjustments, safe operation and applicable warranty policy.

Date _____ Dealer's signature _____

The above equipment and operator's manual have been received by me and I have been thoroughly instructed as to care, adjustments, safe operation, and applicable warranty policy.

Date _____ Owner's signature _____