

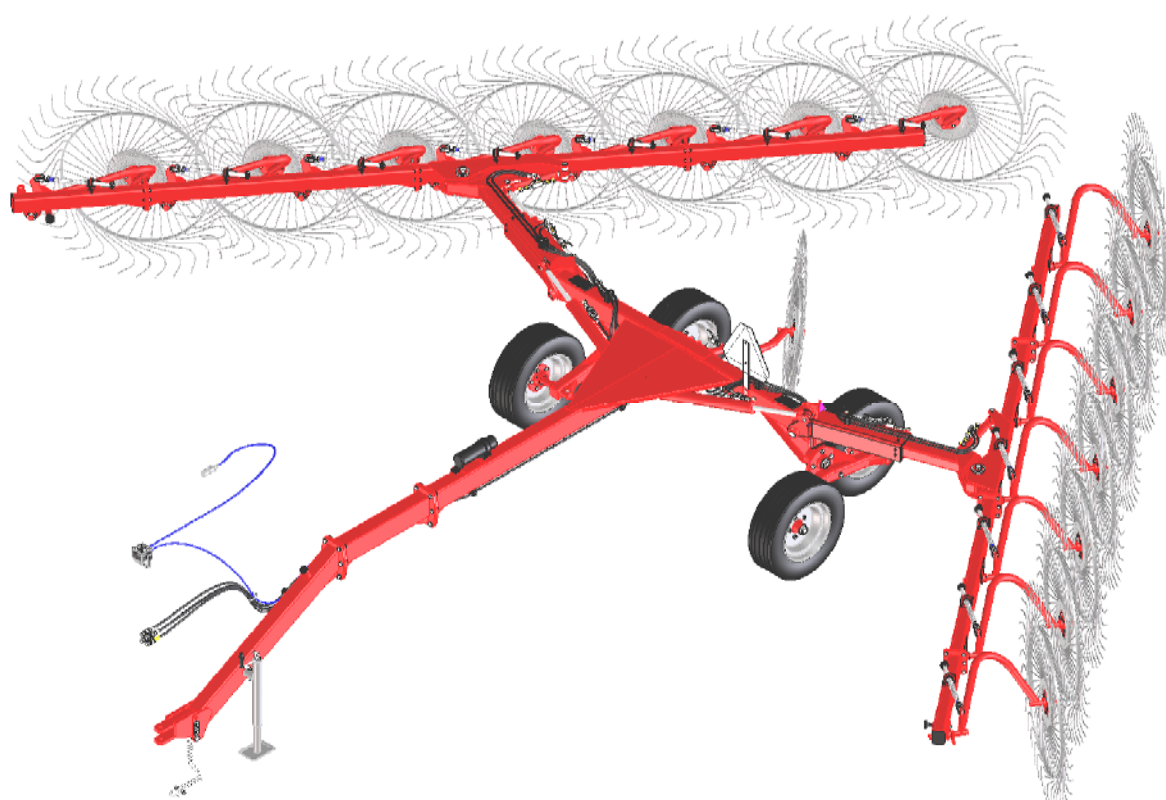

AGRICULTURAL MACHINERY

**sitrex**®  
Spa

## ASSEMBLY, USE AND MAINTENANCE



# QRX 12/14



---

## INDEX

SECTION 1	GENERAL INFORMATION	2
1.1	WARRANTY	2
SECTION 2	GUIDE TO THE SIGNS AND SYMBOLS USED	3
2.1	SIGNS AND SYMBOLS	3
2.2	WARNING SIGNS	3
2.3	WARNINGS IN THE MANUAL	5
2.4	INDICATION SIGNS	5
SECTION 3	TECHNICAL SPECIFICATIONS	6
3.1	MACHINE TECHNICAL SPECIFICATIONS	6
3.2	CHARACTERISTICS OF HYDRAULIC/ELECTRIC COMPONENTS	6
3.3	MACHINE IDENTIFICATION	7
3.4	MACHINE IDENTIFICATION DATA	8
SECTION 4	ASSEMBLY	9
4.1	DELIVERY AND UNPACKING	9
4.2	ASSEMBLY INSTRUCTIONS	10
4.3	METRIC-INCHES CONVERSION TABLE	11
4.4	MACHINE ASSEMBLY	12
4.5	HYDRAULIC SYSTEM ASSEMBLY	21
4.6	ELECTRICAL SYSTEM ASSEMBLY	28
4.7	CENTER RAKE WHEEL KIT (OPTIONAL)	29
4.8	ASSEMBLY OF CONVERSION KIT FROM QRX12 TO QRX14	33
4.9	GREASING POINTS	35
SECTION 5	ADJUSTMENT, PREPARATION AND USE	36
5.1	HITCHING THE MACHINE TO THE TRACTOR	36
5.2	UNHITCHING THE MACHINE FROM THE TRACTOR	37
5.3	ELECTRIC SELECTOR	38
5.4	ROAD TRANSPORT	41
5.5	COMPLIANCE WITH THE HIGHWAY CODE	43
5.6	WORKING POSITION	43
5.7	ADJUSTING THE PRESSURE OF THE RAKE WHEELS ON THE GROUND	44
5.8	WORKING POSITION ADJUSTMENTS	45
5.9	WORKING ON ONE SIDE ONLY	46
5.10	Locking the rake wheel arms in the raised position	48
SECTION 6	GENERAL INSTRUCTIONS FOR MAINTENANCE	49
6.1	REPAIR WORK	49
6.2	STORAGE FOR LONG PERIODS	49
6.3	MAINTENANCE INSTRUCTIONS	50
6.4	TIRES	50
6.5	HYDRAULIC CIRCUIT	50
6.6	SCRAPPING THE MACHINE	51

---

## SECTION 1 GENERAL INFORMATION

### 1.1 WARRANTY

When the machine is received, check to make sure that it has not been damaged during shipping and that all the accessories are present. Claims must be made to the sales agent in writing within 8 days from receipt.

The manufacturer warrants new machinery to be free from defects in materials and workmanship at the time of delivery to the original purchaser if correctly set up and operated according to this Operator's Manual.

The manufacturer will repair or replace free of charge any defective part which is returned by the purchaser (freight prepaid) and found to be defective on inspection authorized by the manufacturer during the warranty period.

This warranty shall be valid for 12 (twelve) months from the delivery of the goods to the original purchaser.

If the customer is unable to return the defective part to the manufacturer, the manufacturer cannot be held liable for any costs due for repair or replacement of any part of the machine. The manufacturer shall only supply the part(s) required for such repair and/or replacement.

The warranty shall be considered null and void when it is evident that the machine has been improperly used or has been repaired without authorization.

The manufacturer shall not be held liable for any obligation or agreement reached by any employers, agents or dealers who do not comply with the above warranty. The manufacturer cannot be held liable for the subsequent damages. This warranty replaces any other warranty, either explicit or implied, as well as any other obligation of the manufacturer.

#### **NOTE:**

ALL WORK UNDER WARRANTY OR REPLACEMENTS MUST BE APPROVED BY THE MANUFACTURER BEFORE WORK BEGINS.

ANY WORK OR REPAIRS MADE BEFORE BEING SEEN AND APPROVED BY THE MANUFACTURER WILL NOT BE COVERED UNDER WARRANTY

PLEASE NOTIFY YOUR SALES & SERVICE DEPARTMENT OF THIS POLICY.

---

## SECTION 2 GUIDE TO THE SIGNS AND SYMBOLS USED

### 2.1 SIGNS AND SYMBOLS

These signs and symbols give information to the operator on how to make the best use of the machine so as to prolong its life, avoid damage, optimize work and, above all, to avoid injury to the operator and anyone within range of the machine.

### 2.2 WARNING SIGNS

Fig. 2.1

Read carefully the user's manual and follow all the safety instructions.

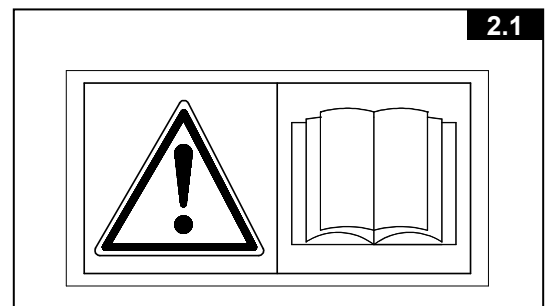

Fig. 2.2

Before doing any checking, maintenance and/or repair operations, stop in a suitable place, turn off the tractor, apply the brake, remove the key from the ignition and consult this manual.

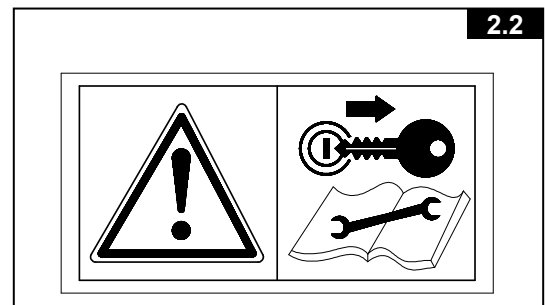

Fig. 2.3

Warns against the potential and serious risk of crushing your hands. Keep at a safe distance.

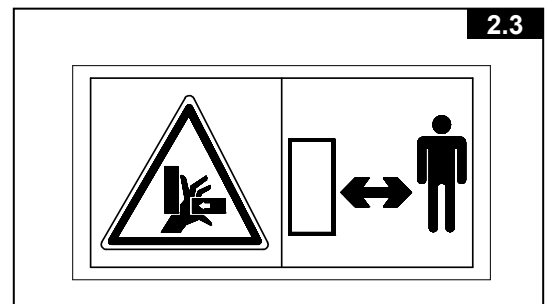

Fig. 2.4

Warns against the potential and serious risk of injury to the feet. Keep at a safe distance.

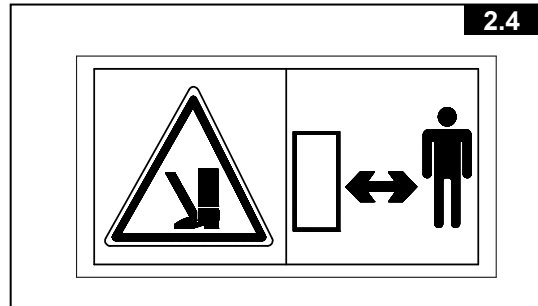

Fig. 2.5

Warns against the potential and serious risks for the driver and/or other persons who are riding improperly on the tractor and/or on the machine.



Fig. 2.6

Summarizes all the potential and serious dangers encountered during the assembly, use, maintenance and/or repair of the machine.

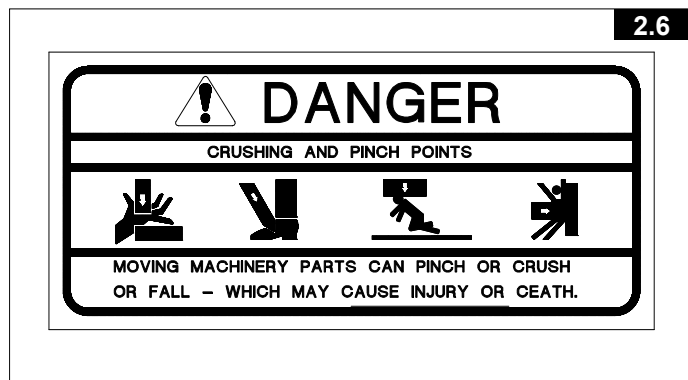

Fig. 2.7

Indicates the maximum speed allowed during road transport (19 MPH - 30 Km/h).

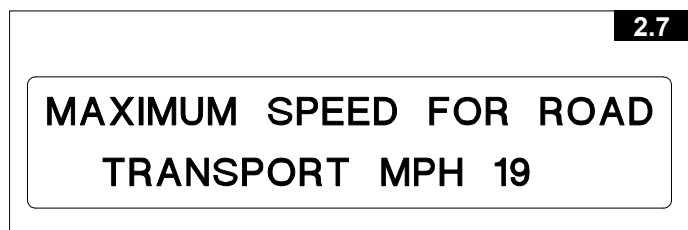
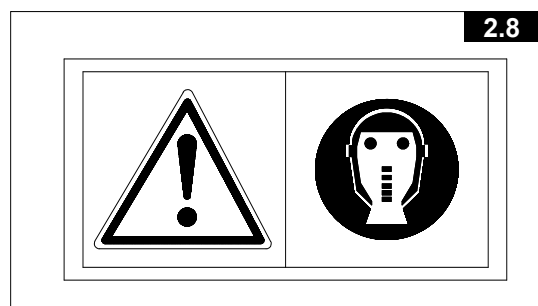

Fig. 2.8

Recommends the wearing of suitable protective equipment and clothing to prevent injury when carrying out assembly, use, maintenance and repair operations.



---

## 2.3 WARNINGS IN THE MANUAL

Fig.2.9

Indicates an imminently hazardous situation which, if not avoided, could result in death or serious personal injury.



Fig.2.10

This indicates a potential hazard that, if not avoided, could result in serious personal injury. It also warns not to remove protective devices.



## 2.4 INDICATION SIGNS

Fig. 2.11

Indicates the components to be assembled and/or identified on the right or left side of the machine (Fig.4.1). The RH and LH sides are determined by standing behind the machine and looking forward.

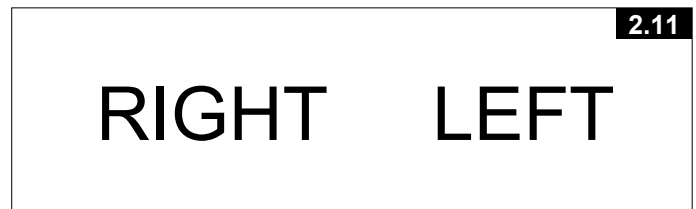

Fig.2.12

Indicates a greasing point.



## SECTION 3 TECHNICAL SPECIFICATIONS

### 3.1 MACHINE TECHNICAL SPECIFICATIONS

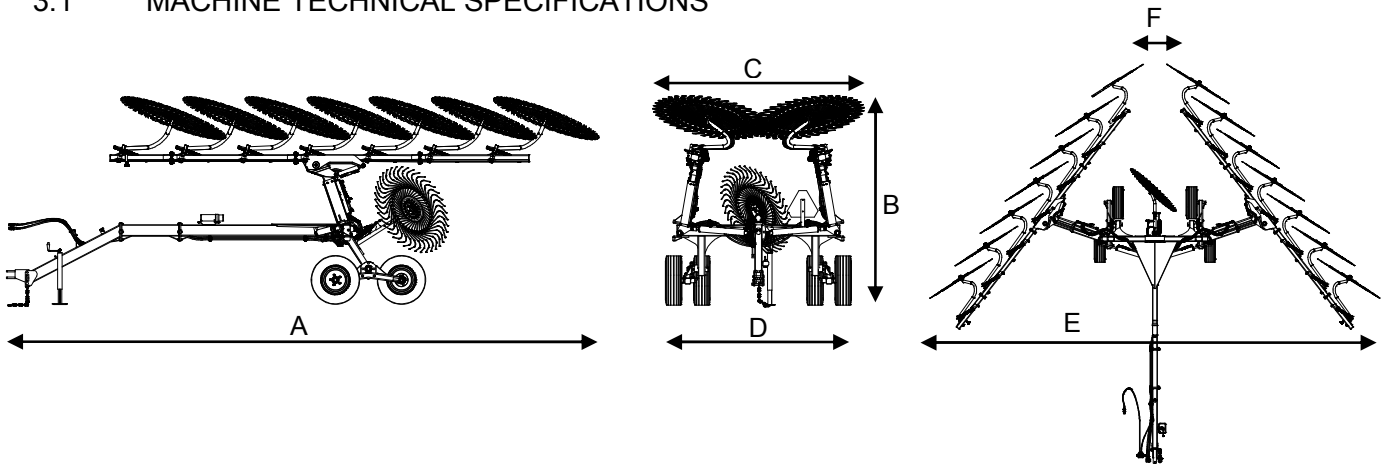

MODEL	QRX 12	QRX 14
Rake Wheels	12	14
Rake Wheel Diameter	55" (1.4m)	55" (1.4m)
Rake Wheel Diameter (optional)	60" (1.52m)	60" (1.52m)
Maximum Windrow Width (F)	6' 7" (2m)	6' 7" (2m)
Minimum Windrow Width (F)	3' (0.9m)	3' (0.9m)
Maximum Working Width (E)	25' 1" (7.65m)	28' (8.5m)
Minimum Working Width (E)	21'12" (6.7m)	24'11" (7.6m)
Minimum Transport Height (B)	9'2" (2.8m)	9'2" (2.8m)
Tractor Requirements	HP 50 (36.7 KW)	HP 60 (44 KW)
Tires	205-75/15	205-75/15
Transport Width (C)	9'2" (2.8m)	9'2" (2.8m)
Transport Length (A)	23'9" (7.24m)	26'5" (8.04m)
Tread Width (D)	8'1½" (2.48m)	8'1½" (2.48m)
Weight *	2855 lbs - 1295 kg	3240 lbs - 1470 kg

\* Full optional

### 3.2 CHARACTERISTICS OF HYDRAULIC/ELECTRIC COMPONENTS

Power supply: 12 V DC 7-pin connector ISO1185 (3-pin connector DIN9680 on request, see fig.5.6)

Characteristics of solenoid valve coils: 12 V DC – 60 Watt

Fuse 5 A

Working pressure of hoses, fittings, cylinders etc. : 200 bar – 2800 psi



### 3.3 MACHINE IDENTIFICATION

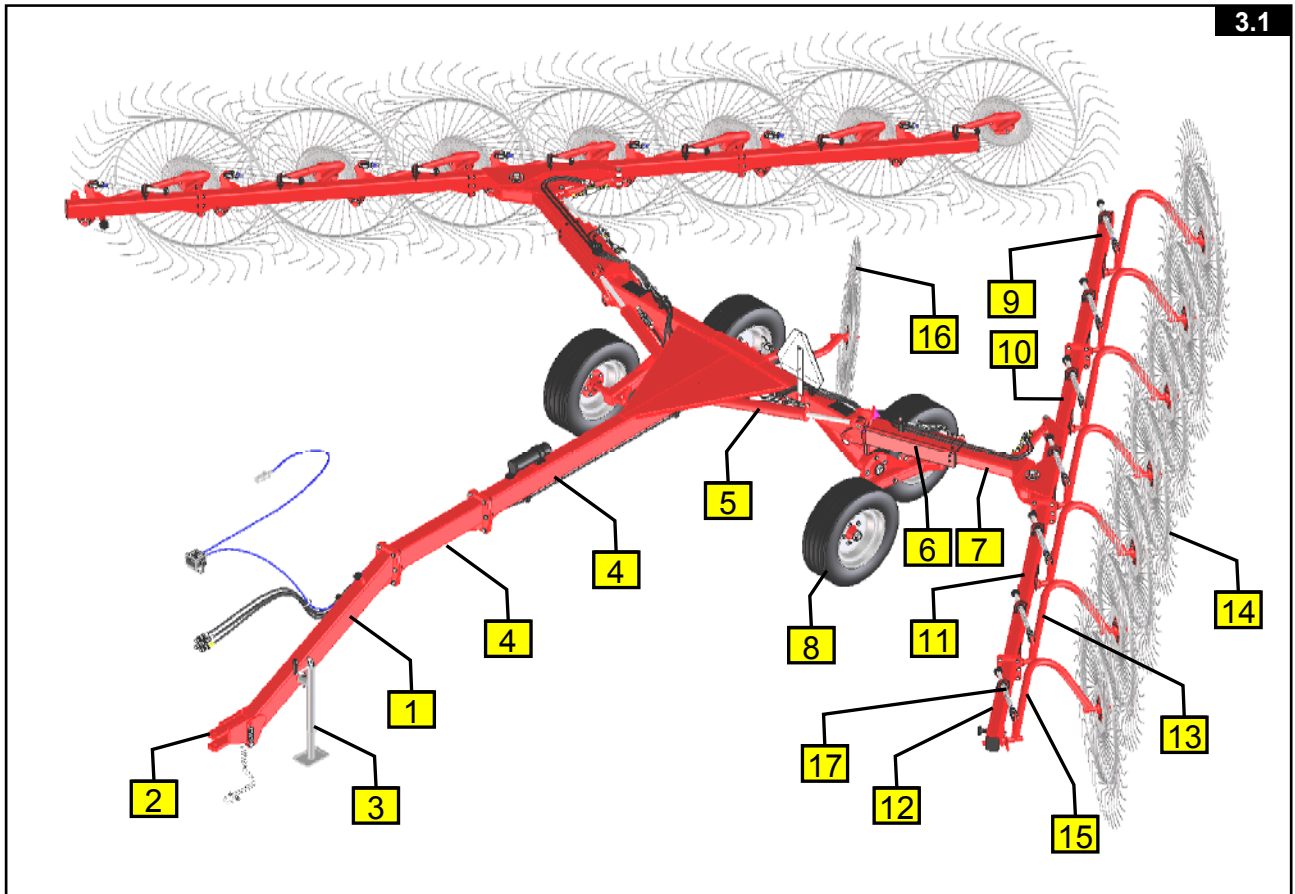

- 1) INCLINED DRAWBAR
- 2) HITCH
- 3) PARKING STAND
- 4) HORIZONTAL DRAWBAR
- 5) LEFT FOLD-UP CYLINDER
- 6) LEFT FOLD-UP ARM
- 7) LEFT TELESCOPING ARM
- 8) LEFT TANDEM WHEEL AXLE
- 9) LEFT REAR SECTION
- 10) LEFT CENTR. SECTION
- 11) LEFT FRONT SECTION
- 12) LEFT EXTENSION SECTION
- 13) LEFT RAKE WHEEL ARM
- 14) LEFT RAKE WHEEL
- 15) LEFT SPECIAL RAKE WHEEL ARM
- 16) CENTER RAKE WHEEL KIT (optional)
- 17) SPRING ASSEMBLY

---

### 3.4 MACHINE IDENTIFICATION DATA

The machine is identified by the following data:

- Machine type
- Serial number
- Year of manufacture
- WEIGHT

stamped on the nameplate attached to the machine frame and to be specified when requesting spare parts or information.

Optional

Center rake wheel kit



---

## SECTION 4 ASSEMBLY

### 4.1 DELIVERY AND UNPACKING.

The machine is delivered partially assembled in n° 1 crate which also contains n° 6 cardboard boxes.

The cardboard boxes contain all the various accessories for assembly (pins, screws, fittings, etc.). The small box not marked with a letter contains the reflector triangle to be attached to the machine.

All components are inspected by the manufacturer before shipment. Upon receipt of the machine, check that the crate is intact and that the contents have not been damaged during shipment. If any damage and/or irregularities are found, report them immediately to your dealer.

**Note: The packaging is made from wood, plastic film, cardboard and steel, and must be disposed of according to applicable laws in your locality.**

Handle the crates received using lifting devices suitable for lifting the weight indicated and for providing stability for the crates and pallets in consideration of their size and shape.

## 4.2 ASSEMBLY INSTRUCTIONS

Examples of general measurements for identifying the assembly accessories based on type (Fig. 4.1)

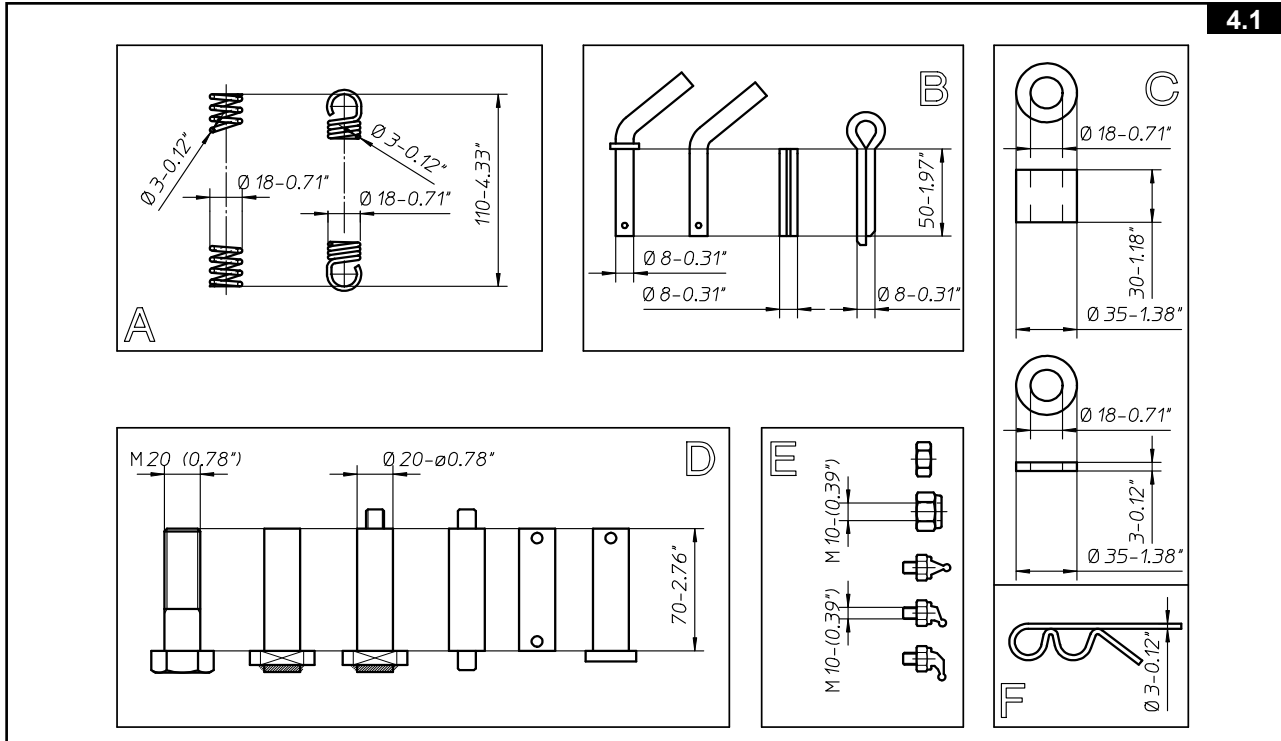

For tightening torques, see the table below (the class of the material is normally stamped on the head of the bolts). (Fig. 4.2)

NOMINAL SIZE	CLASS 5.8		CLASS 8.8		CLASS 10.9		LOCKNUT CL.8 W/CL8.8 BOLT
	UNPLATED	PLATED W/ZnCr	UNPLATED	PLATED W/ZnCr	UNPLATED	PLATED W/ZnCr	
M 4	1.7 (15)*	2.2 (19)*	2.6 (23)*	3.4 (30)*	3.7 (33)*	4.8 (42)*	2.3 (20)*
M 6	5.8 (51)*	7.6 (67)*	8.9 (79)*	12 (102)*	13 (155)*	17 (150)*	7.8 (69)*
M 8	14 (124)*	18 (159)*	22 (195)*	28 (248)*	31 (274)*	40 (354)*	19 (169)*
M 10	28 (21)	36 (27)	43 (32)	58 (41)	61 (45)	79 (58)	38 (28)
M 12	49 (36)	63 (46)	75 (55)	97 (72)	107 (79)	138 (102)	66 (49)
M 16	121 (89)	158 (117)	186 (137)	240 (177)	266 (196)	344 (254)	164 (121)
M 20	237 (175)	307 (226)	375 (277)	485 (358)	519 (383)	671 (495)	330 (243)
M 24	411 (303)	531 (392)	648 (478)	839 (619)	897 (662)	1160 (855)	572 (422)

NOTE: torque values shown with\* are inch pounds

**⚠ WARNING !!! ⚠**

**Assembly must be done carefully and accurately, for the safety of the person(s) doing the assembling and to ensure proper machine operation.**

**Assembly should be done on a flat, solid surface, using the proper tools and wearing suitable clothing, making sure that all people not involved in the assembly are kept at a safe distance. Assemblers must provide suitable lifting mechanisms and supports for stabilizing the partially assembled units, so as to prevent them from falling and causing damage or injury. The steps for assembly are illustrated in following. Depending on the experience of the assemblers and the tools available, it is not necessary that the instructions be followed in the exact order shown here, but the safety precautions described above must always be strictly and carefully followed.**

**4.3 METRIC-INCHES CONVERSION TABLE**

mm	inches	mm	inches	mm	inches	mm	inches
1	1/32"	26	1"1/64	55	2"5/32	300	11"51/64
2	5/64"	27	1"1/16	60	2"23/64	350	13"49/64
3	7/64"	28	1"3/32	65	2"35/64	400	15"47/64
4	5/32"	29	1"9/64	70	2"3/4	450	17"45/64
5	3/16"	30	1"11/64	75	2"15/16	500	19"43/64
6	15/64"	31	1"7/32	80	3"9/64	550	21"41/64
7	17/64"	32	1"1/4	85	3"11/32	600	23"39/64
8	5/16"	33	1"19/64	90	3"17/32	650	25"37/64
9	11/32"	34	1"21/64	95	3"47/64	700	27"35/64
10	25/64"	35	1"3/8	100	3"59/64	750	29"33/64
11	27/64"	36	1"13/32	110	4"21/64	800	31"31/64
12	15/32"	37	1"29/64	120	4"23/32	850	33"29/64
13	1/2"	38	1"31/64	130	5"7/64	900	35"27/64
14	35/64"	39	1"17/32	140	5"1/2	950	37"25/64
15	37/64"	40	1"9/16	150	5"57/64	1000	39"23/64
16	5/8"	41	1"39/64	160	6"19/64	1050	41"21/64
17	21/32"	42	1"41/64	170	6"11/16	1100	43"19/64
18	45/64"	43	1"11/16	180	7"5/64	1150	45"17/64
19	47/64"	44	1"23/32	190	7"15/32	1200	47"15/64
20	25/32"	45	1"49/64	200	7"55/64	1250	49"13/64
21	13/16"	46	1"51/64	210	8"17/64	1300	51"11/64
22	55/64"	47	1"27/32	220	8"21/32	1350	53"9/64
23	57/64"	48	1"7/8	230	9"3/64	1400	55"7/64
24	15/16"	49	1"59/64	240	9"7/16	1450	57"5/64
25	31/32"	50	1"61/64	250	9"53/64	1500	59"3/64

#### 4.4 MACHINE ASSEMBLY

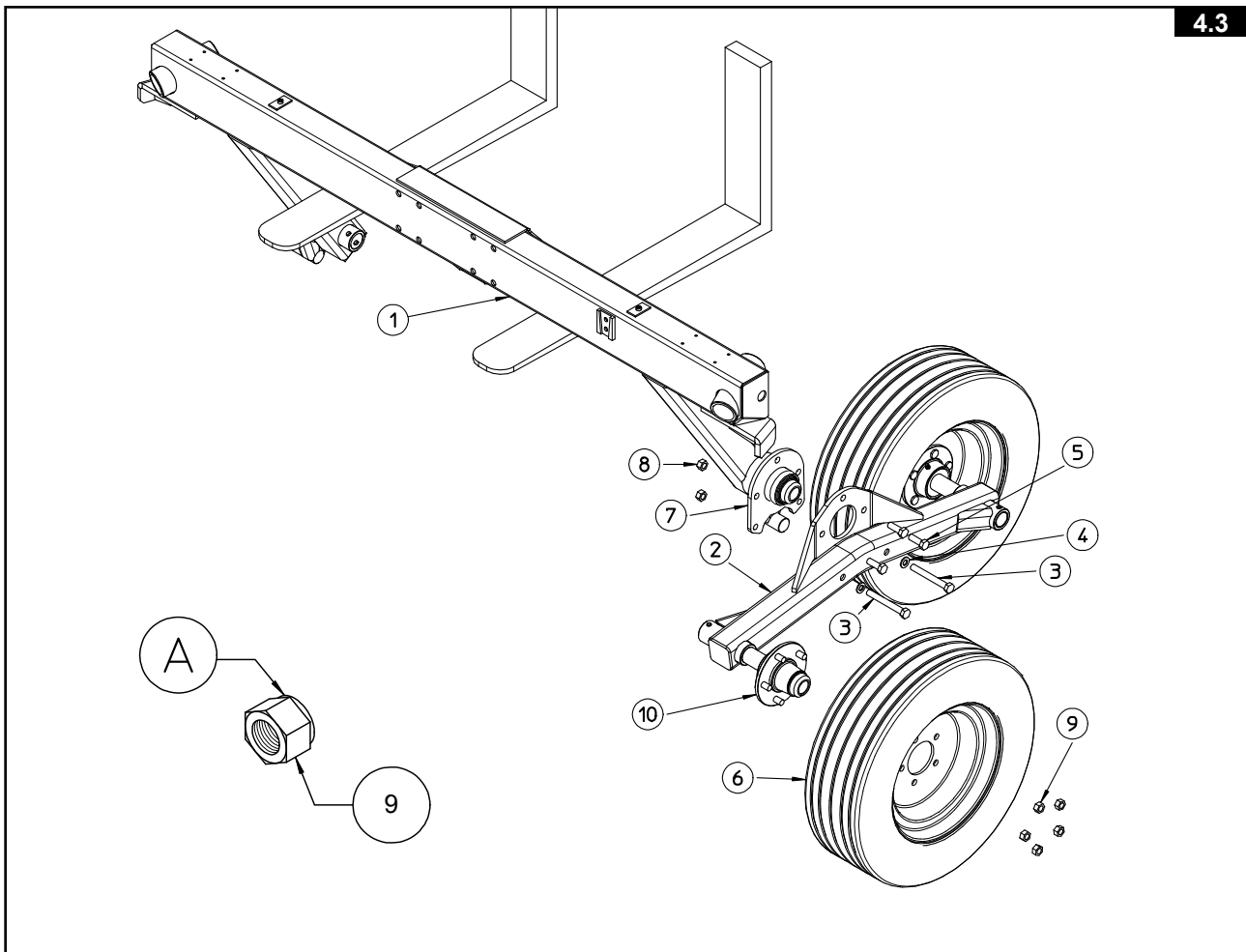

**STEP 1** - With reference to Fig. 4.3, carry out the operations in the following order:

- 1) Attach the wheels (6) to the hubs (10) already fastened to the axle unit (2) using the special nuts (9) with a tightening torque of 120 ft. lbs. (16.3 daNm).
- 2) The spherical part "A" of the special nut (9) must always be facing the wheel.
- 3) Support the crosspiece (1) with the forks of a forklift.
- 4) Fasten the axle unit (2) to the hub (7) on the right side of machine (see fig. 4.4) using the bolts (5) and (3), the washers (4) for bolts (3), and nuts (8).
- 5) Screw in grease nipple on hub (7)
- 6) Repeat the same operations on the other side of the machine.

Item 3	4	bolts M16x130 (5/8"x 5" 7/64) DIN 931 - UNI 5737
Item 4	4	washer $\varnothing 16-\varnothing 48 \times 4$ ( $\varnothing 5/8-\varnothing 1" 7/8 \times 5/32$ )
Item 5	6	bolt M16x45 (5/8"x 1" 49/64) DIN 933 - UNI 5739
Item 8	10	nut M16 (5/8") DIN 980
Item 9	20	nut M16 (5/8") spherical
Item 10	2	Grease nipple M8 (5/16")

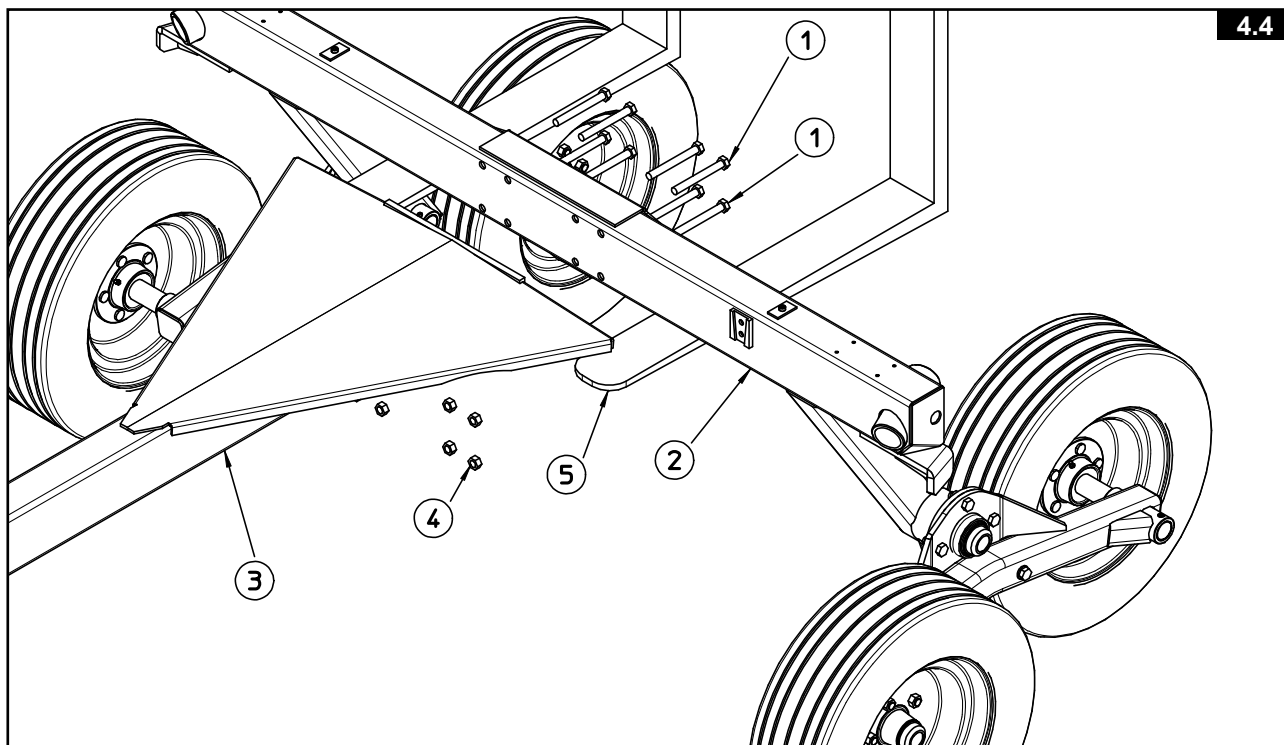

**STEP 2** - With reference to Fig.4.4, carry out the operations in the following order:

Connect the horizontal drawbar (3) to the frame (2) using bolts (1) and nuts (4).

Item (1) : 8 bolts M16x140 (5/8"x 5 1/2") DIN 931

Item (4) : 8 nuts M16 (5/8") DIN 980

ONLY FOR THE QRX/14.

**STEP 3** - With reference to Fig. 4.5, carry out the operations in the following order:

Insert and connect the additional drawbar (2) between drawbars (1) and (3), fastening it with bolts (4) and nuts (5).

Item (4): 6+6 bolts M16x50 (5/8"x 2") DIN 931

Item (5): 6+6 nuts M16 (5/8") DIN 980

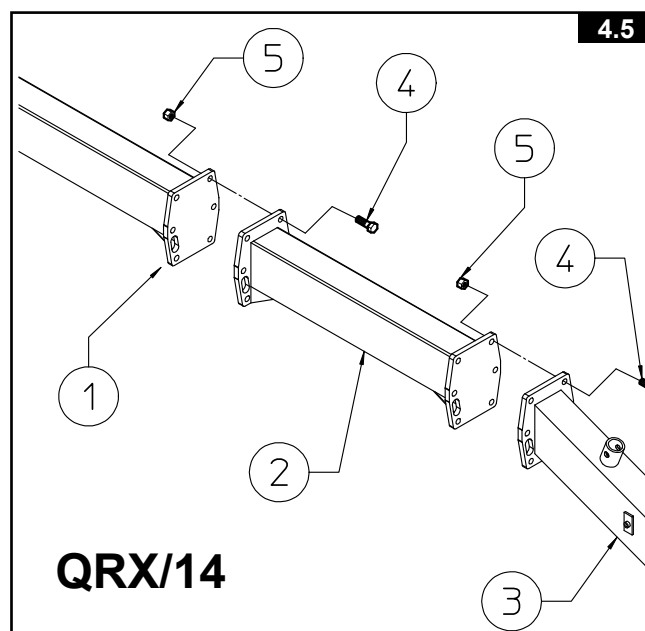

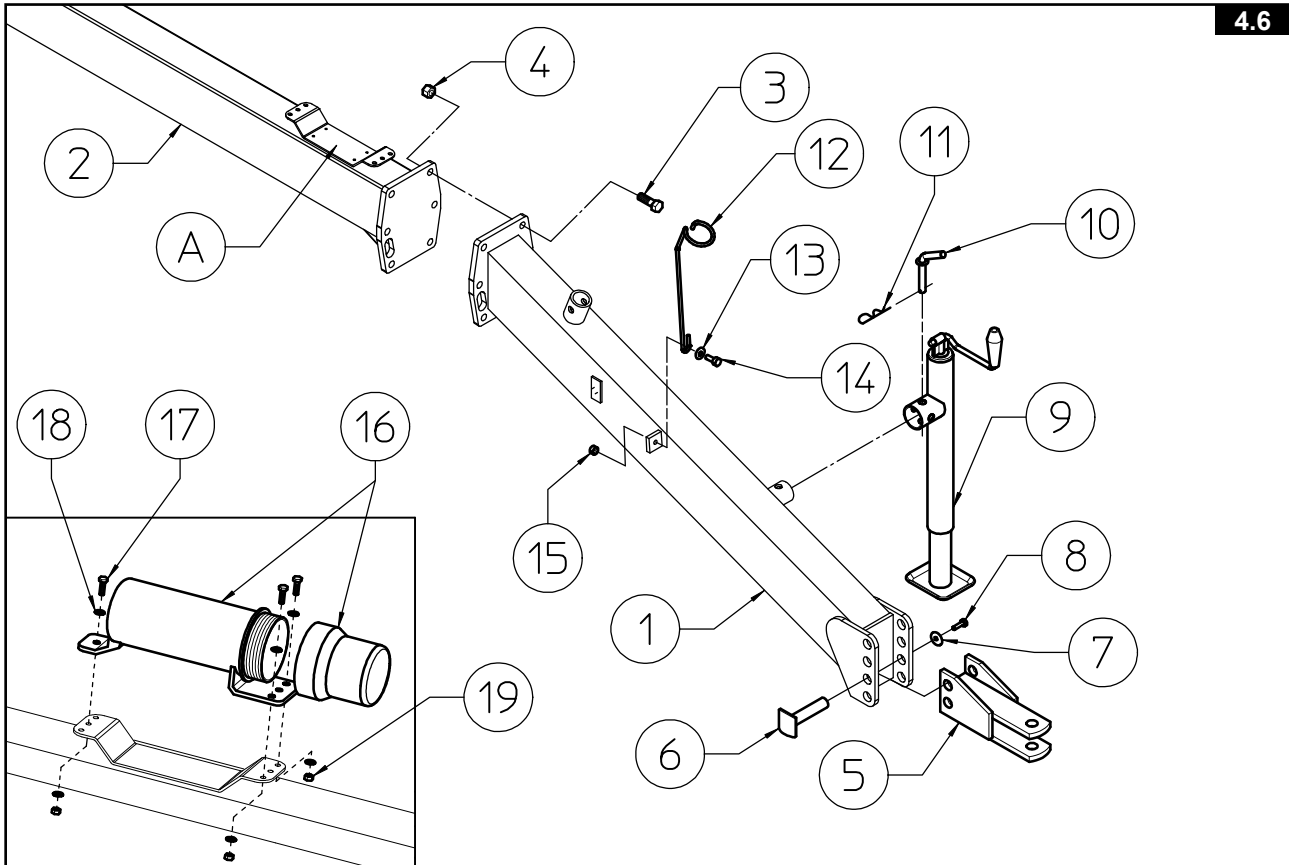

**STEP 4** - With reference to Fig. 4.6, carry out the operations in the following order:

- 1) Connect the inclined drawbar (1) to the horizontal drawbar (2) using bolts (3) and nuts (4). Fasten the hitch for the tractor (5) to the drawbar (1) using the two pins (6), the fastening bolts (8) and the washers (7).
- 2) To adjust the hitch (5), see section 5.1
- 3) Fasten the parking stand (9) to the drawbar (1), using the pin with handle (10) and R-clip (11).
- 4) Attach the hose bracket (12) in its place on the drawbar (1) using the bolt (14), washer (13) and nut (15).
- 5) Attach the manual canister (16) at point (A) on the drawbar (2) using the bolts (17), washers (18) and nuts (19). Note: all the manuals and documents regarding the machine must be kept in the manual canister (16) so that they may consulted at any time.

- Item (3): 6 bolts M16x50 (5/8"x 2") DIN 931  
 Item (4): 6 nuts M16 (5/8") DIN 980  
 Item (6): 2 pins  $\varnothing 25 \times 124$  (1"x5")  
 Item (7): 2 washers  $\varnothing 12-36 \times 2.5$  ( $\varnothing 15/32$ "-1"27/64x 3/32")  
 Item (8): 2 bolts M12x20 (15/32"x13/16") DIN 933  
 Item (10): 1 pin  $\varnothing 15 \times 78$  ( $\varnothing 19/32$ "x 3 1/8")  
 Item (13): 1 washer  $\varnothing 12-36 \times 2.5$  ( $\varnothing 15/32$ "-1"27/64x 3/32")  
 Item (14): 1 bolt M12x35 (15/32"x 1 5/8") DIN 933  
 Item (15): 1 nut M12/36 (15/32") DIN 980  
 Item (17): 3 bolts M6x20 (0.24"x0.79") DIN 933  
 Item (18): 6 washers  $\varnothing 6.6-18 \times 2$  ( $\varnothing 0.26$ "- 0.71"x0.08")  
 Item (19): 3 nuts M6 (0.24") DIN 980



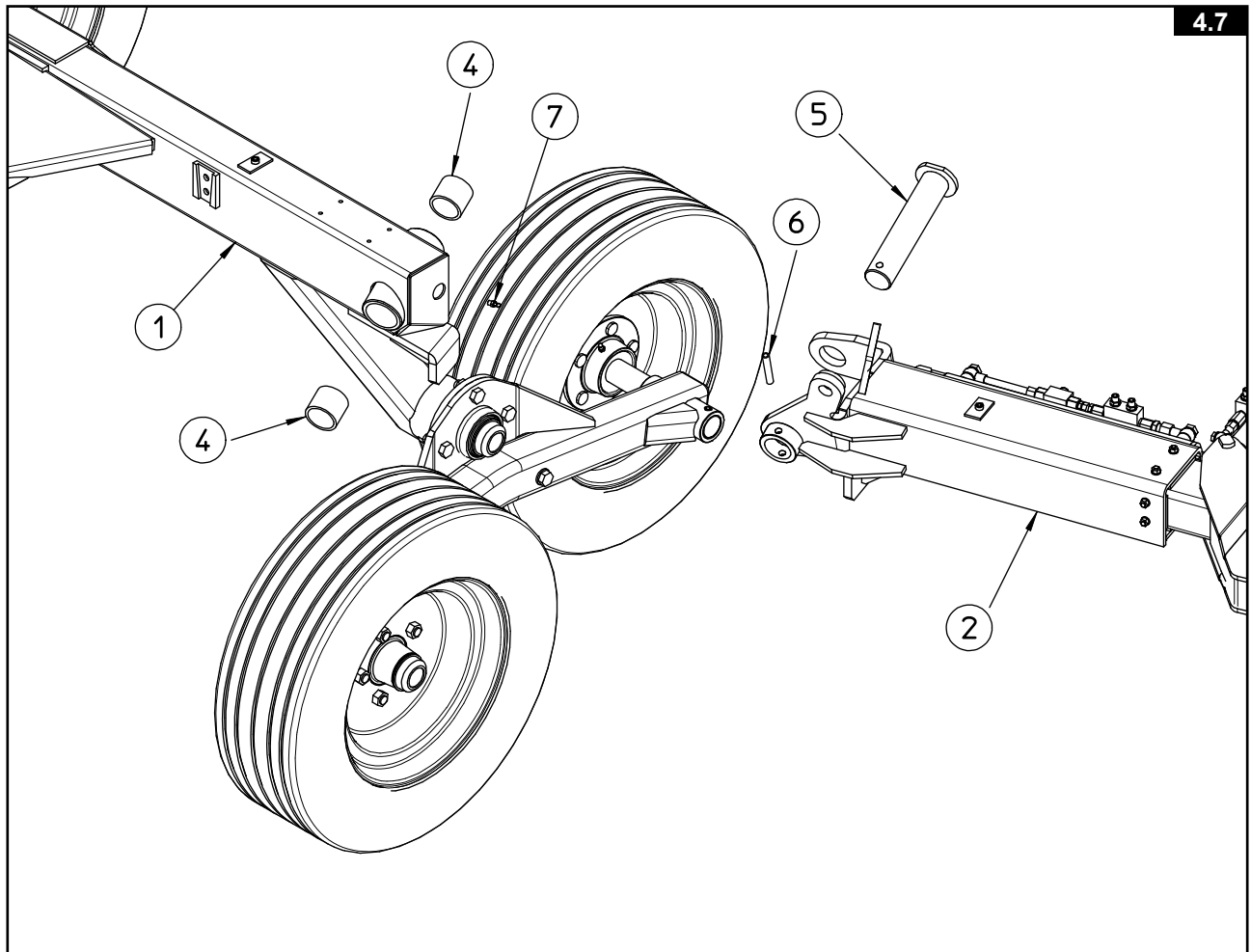

**STEP 5** - With reference to Fig. 4.7, carry out the operations in the following order:

- 1) Insert the bushings (4) in the openings in the frame (2).
- 2) Screw in the grease nipple (7) into its hole on the frame (2).
- 3) Connect the fold-up arms (2) to the frame (2) with the pin (5) and fasten all with the spring pin (5).
- 4) Repeat the same operations on the other side of the machine

Item (5): 2 pins  $\varnothing 50 \times 243$  ( $\varnothing 2 \times 9 \frac{1}{2}$ " )

Item (6): 2 spring pins  $\varnothing 12 \times 70$  ( $\varnothing 1/2$ "  $\times 2 \frac{3}{4}$ " ) DIN 1481

Item (7): 2 grease nipples M8 (5/16")

Item (4): 4 plastic bushings  $\varnothing 50-60 \times 50$  (2"-2  $\frac{3}{8}$ "  $\times 2$ " )

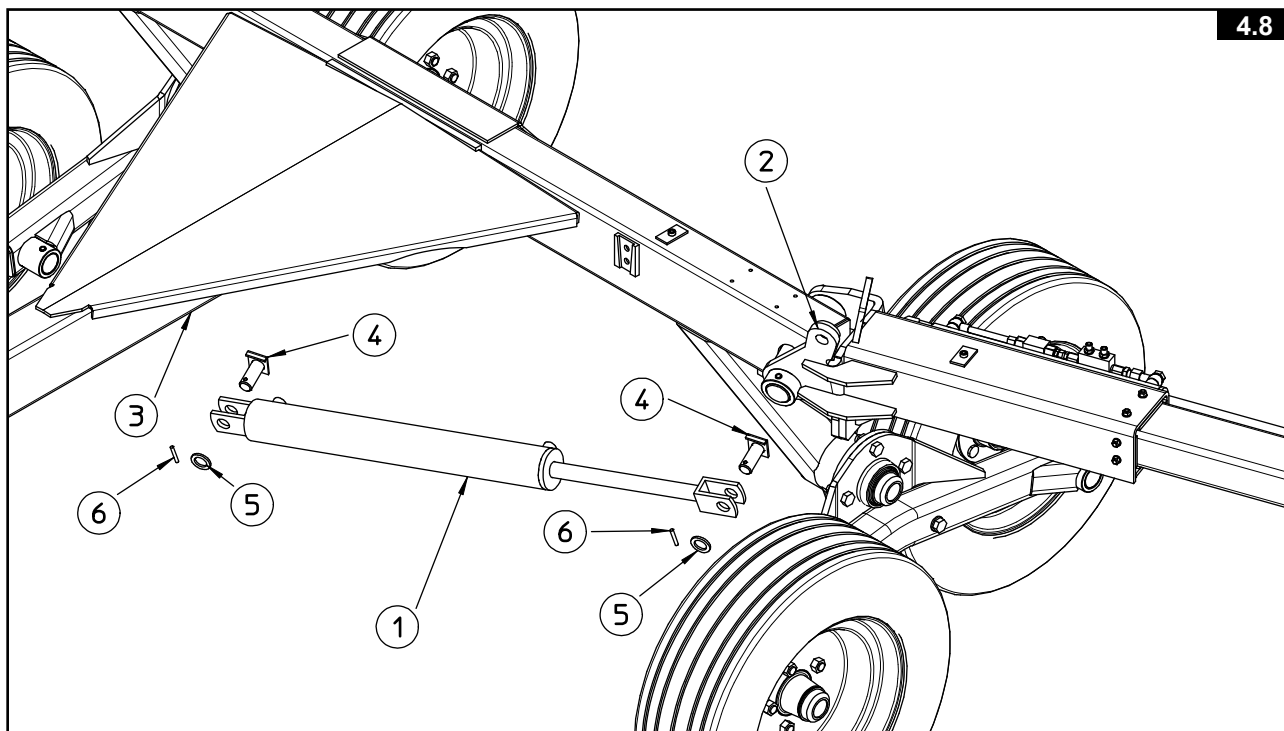

**STEP 6** - With reference to Fig. 4.8, carry out the operations in the following order:

Fasten the cylinders (1) to the frame (3) and (2) using the pins (4), washers (5) and pins (6). Repeat the same operations on the other side of the machine

Item (4): 4 pins  $\varnothing 25 \times 58$  ( $\varnothing 1 \times 2 \frac{5}{16}$ "

Item (5): 4 washers  $\varnothing 25$  ( $\varnothing 1$ " ) DIN 125A

Item (6): 4 pins  $\varnothing 6 \times 35$  ( $\varnothing 1/4$ " x  $1 \frac{1}{2}$ " )  
DIN 94

**STEP 7** - With reference to Fig. 4.9 carry out the operations in the following order:

- 1) Fasten the cylinder (1) on hitch point (5) with pin (2), washer (4), nut (3). The lever of valve of cylinder (1) are content in accessories bag.
- 2) Fasten the cylinder (6) with pins (7), spacer (8), washer (4), nut (3). Pay attention on position of valve (9).
- 3) Repeat the same operations on the other side of the machine

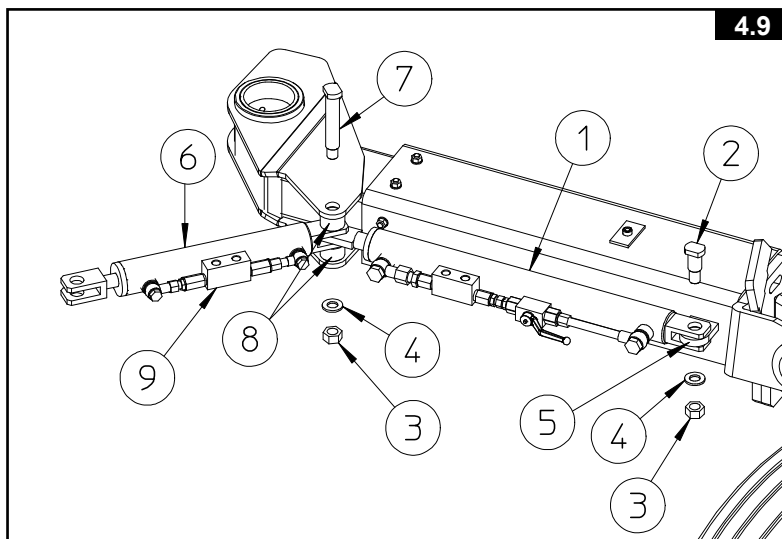

Item (2): n°2 pins  $\varnothing 20 \times 60$  ( $\varnothing 25/32$ " x  $2 \frac{23}{64}$ " )

Item (3): n°4 nuts M16 DIN 980.

Item (4): n°4 washers  $\varnothing 17$  ( $\varnothing 21/32$ " ) DIN 125A

Item (7): n°2 pins  $\varnothing 20 \times 125$  ( $\varnothing 25/32$ " x  $4 \frac{29}{32}$ " )

Item (8): n°4 spacer  $\varnothing 20 \times 34 \times 23$  ( $\varnothing 25/32$ " -  $1 \frac{21}{64}$ " x  $57/64$ " )

**STEP 8** - With reference to Fig. 4.10, carry out the operations in the following order:

- 1) Do not remove the packaging from the springs (11) until the following assembly stages have been completed.
- 2) Insert two nylon bush (9) and screw in grease nipple (10) on support (2).
- 3) Fasten the main section (1) to the telescoping arm (2) inserting the pin (5) into the hole (8) and using the washers (4), (6), bolt (3) and nut (7).
- 4) Connect the cylinder attachment (14) to the section (1) with the pin (12), spacers (13), washer (15) and nut (16).
- 5) Attach the rear section (17) to the main section (1), fastening it with the bolts (19) and nuts (18). Insert the caps (21) in the sections (17).
- 6) Attach the front section (20) to the main section (1), fastening it with the bolts (19) and nuts (18).
- 7) Repeat the same operations on the other side of the machine.

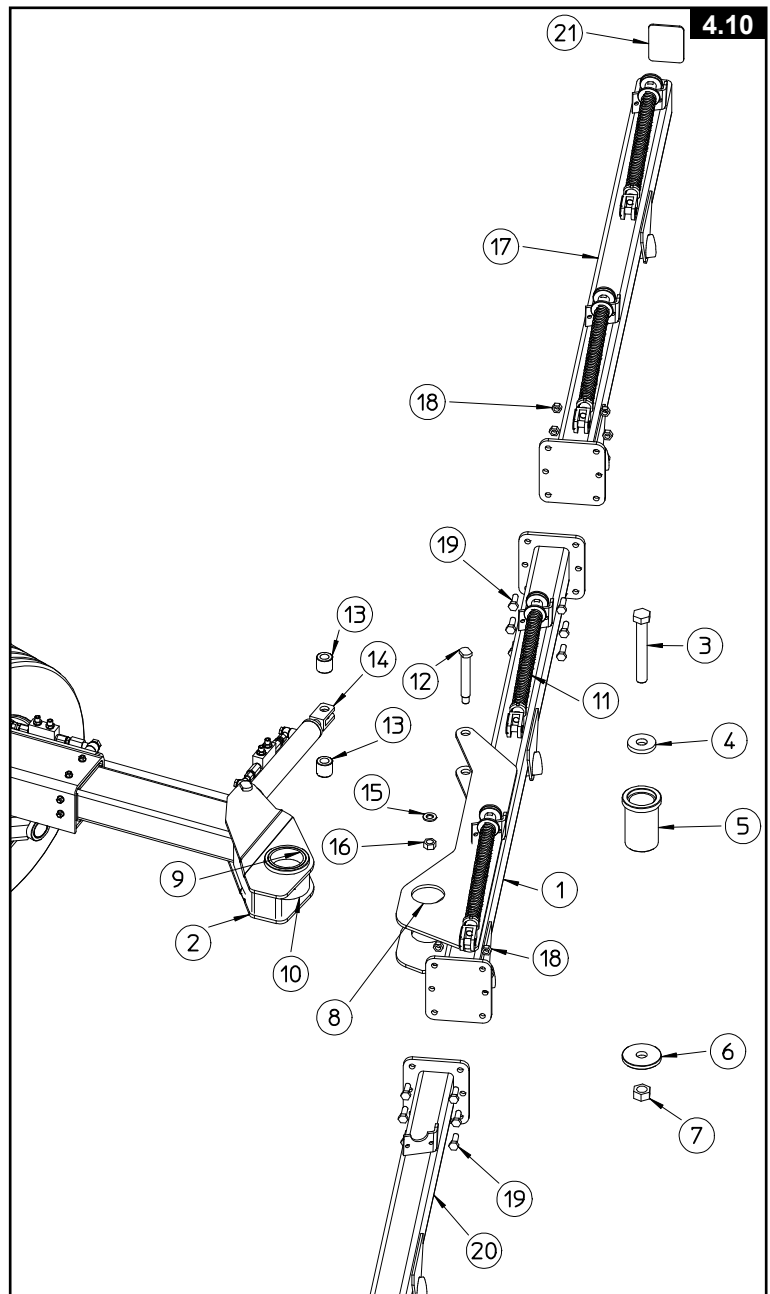

Item (9): 2 nylon bush  $\varnothing 85/75 \times 30$  ( $\varnothing 3 \frac{11}{32} - 2 \frac{15}{16} \times 1 \frac{11}{64}$ )

Item (10): 2 grease nipples M8 (5/16")

Item (3): 2 bolts M24x170 (15/16"x6"11/16) DIN 931

Item (5): 2 pins  $\varnothing 75 \times 107$  ( $\varnothing 2 \frac{15}{16} \times 4 \frac{14}{64}$ )

Item (4): 2 washers  $\varnothing 25/64 \times 10$  ( $\varnothing 1 \frac{1}{2} - 2 \frac{35}{64} \times 25/64$ )

Item (6): 2 washers  $\varnothing 25/90 \times 10$  ( $\varnothing 1 \frac{1}{2} - 3 \frac{17}{32} \times 25/64$ )

Item (7): 2 nuts M24 (1") DIN 980

Item (12): 2 pins  $\varnothing 20 \times 145$  ( $\varnothing 25/32 \times 5 \frac{45}{64}$ )

Item (13): 4 spacers  $\varnothing 20/34 \times 33$  ( $\varnothing 25/32 - 1 \frac{21}{64} \times 1 \frac{19}{64}$ )

Item (15): 2 washers  $\varnothing 16$  ( $\varnothing 5/8$ ) DIN 125A

Item (16): 2 nuts M16 (5/8") DIN 980

Item (19): 12+12 bolts M12x35 (15/32"x1.3") DIN 933

Item (18): 12+12 nuts M12 (15/32") DIN 980

Item (21): 2 plastic caps

ONLY FOR THE QRX/14.

**STEP 9** - With reference to Fig. 4.11, carry out the operations in the following order:

- 1) Attach the extension section (22) to the front section (18), fastening it with the bolts (19) and nuts (18).
- 2) Insert the cap (21) in the extension section (22).
- 3) Repeat the same operations on the other side of the machine.

Item (19): 6+6 bolts M12x35 (15/32"x1.3") DIN 933

Item (18): 6+6 nuts M12 (15/32") DIN 980

Item (21): 2 plastic caps

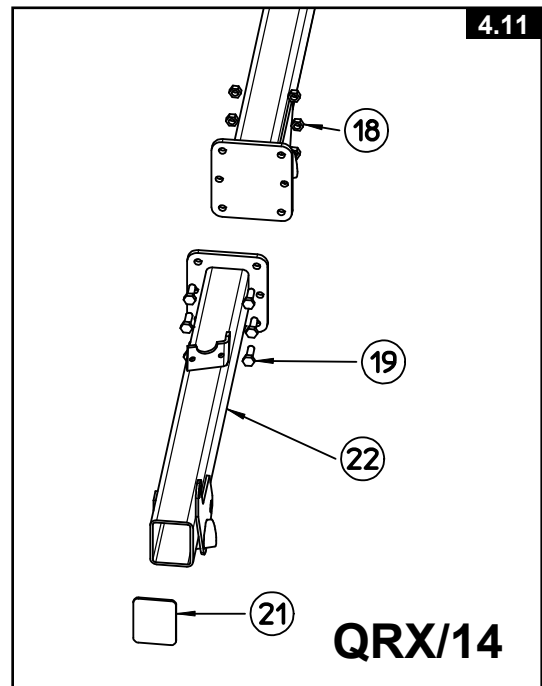

**STEP 10** - With reference to Fig. 4.12, carry out the operations in the following order:

- 1) Insert the plastic bushings (2) in all their seats (5) in the rake sections.

**Before continuing assembly, note in Fig. 4.13 the special rake wheel arm Ref.9 to be mounted only in the end position of the hay rake section where there is the locking knob 10 (for QRX/12 on section 13)**

- 2) Insert the arm (1) and fasten with the washer (3) and the spring pin (4).
- 3) Attach the grease nipple (6) M6 in the threaded hole of the bushings (5).

Item (2): 24/28 plastic bushings  $\varnothing 35-42 \times 26$  ( $\varnothing 1\frac{3}{8}-1\frac{41}{64} \times 1\frac{1}{64}$ )

Item (3): 12/14 washers  $\varnothing 35-50 \times 5$  ( $\varnothing 1\frac{3}{8}-1\frac{61}{64} \times 3/16$ )

Item (4): 12/14 spring pins 8x50 ( $\varnothing 5/16 \times 1\frac{61}{64}$ ) DIN 1481

Item (6): 12/14 grease nipple M6 ( $15/64$ ).

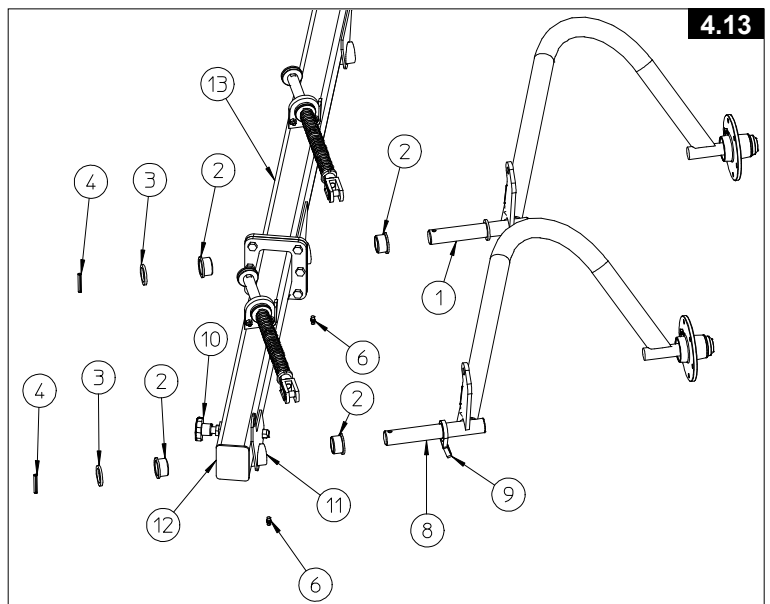
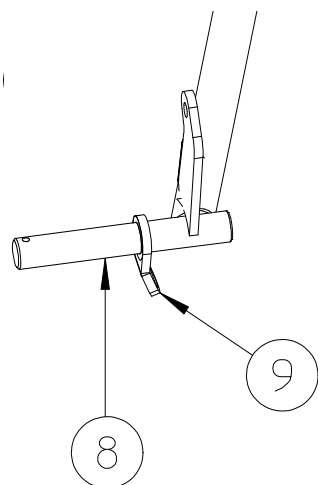
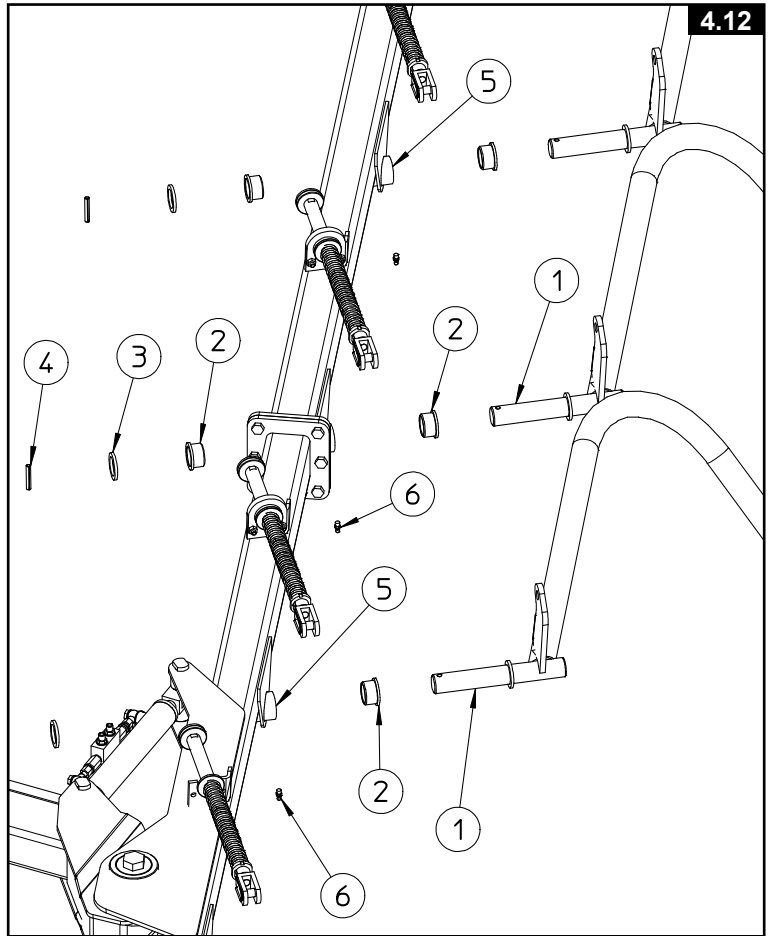

With reference to Fig. 4.14, carry out the operations in the following order:

- 1) Fasten the spring assembly (A) to the arm (2) with the self-locking pin (1).
- 2) Rotate until it clamps on to it.

Item (1): 12/14 pins  $\varnothing 16 \times 36$   
( $\varnothing 5/8 \times 1 \times 13/32$ )

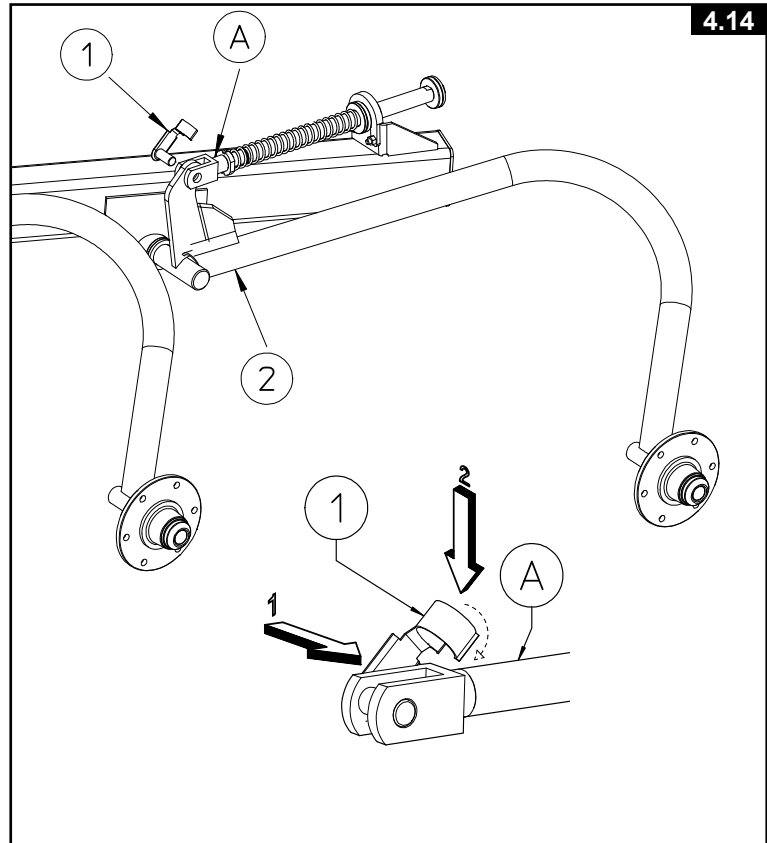

**STEP 11** - With reference to Fig. 4.15, carry out the operations in the following order:

**The rake wheels are different for the right side and the left side of the machine. Fig. 4.15 shows the assembly of the left side.**

Fasten the rake wheel (1) to the hub (2) with the bolts (3) washers (4) and nuts (5).

Item (3): 72/84 bolts M10x25 DIN 933  
( $25/64 \times 1$ )  
Item (4): 72/84 washers  $\varnothing 10.5$  DIN  
127B ( $27/64$ )  
Item (5): 72/84 nuts M10 DIN 934  
( $25/64$ )

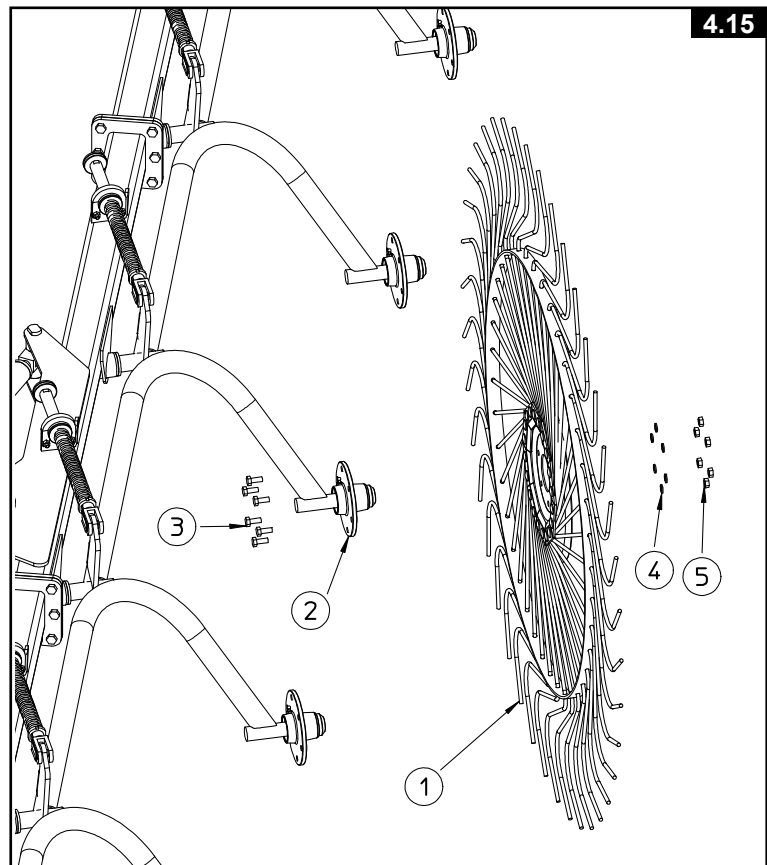

## STEP 12 - SAFETY CHAIN

With reference to Fig.4.16, carry out the operations in the following order:

Attach the safety chain 1 to the holes A in the drawbar using the bolt 2, washer 3 and nut 4.



**ATTENTION !!!**

**Attach the safety chain point A in an appropriate attaching point of tractor.**

Item (2): n°1 screw M22x150 DIN 931 (55/64"x5"57/64")

Item (3): n°1 washer  $\varnothing$ 23 DIN 127B (57/64")

Item (4): n°1 nut M22 DIN 934 (55/64")

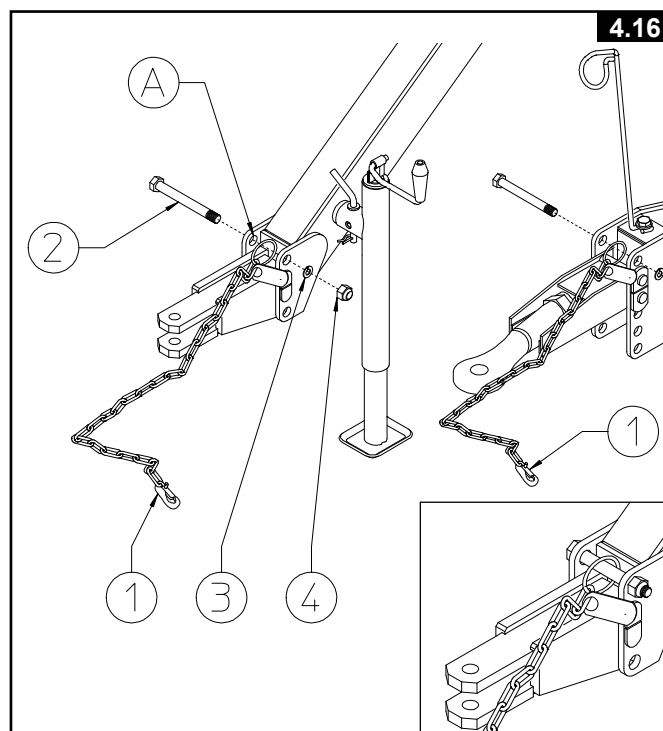

## 4.5 HYDRAULIC SYSTEM ASSEMBLY



**DANGER !!!**



The hydraulic cylinders are empty to start with and very hazardous uncontrolled movements may take place when filling them.

It is recommended that the cylinders be filled before connecting them to the machine, lowering and raising them several times with the controls until the air is removed from the circuit. These operations must take place in conditions of complete safety, with the machine connected to the tractor and the operator sitting in the driver's seat, making sure that no persons or objects are within the range of movement of the machine.

When using the system for the first time, make sure there are no oil leaks. If there are any leaks, first of all, tighten all fittings.



**DANGER !!!**



The assembly must be done with care and precision for the safety of the person(s) and to ensure proper machine operation.

Assembly should be done on a flat, solid surface, using the proper tools and wearing suitable clothing, making sure that all people not involved in the assembly are kept at a safe distance.

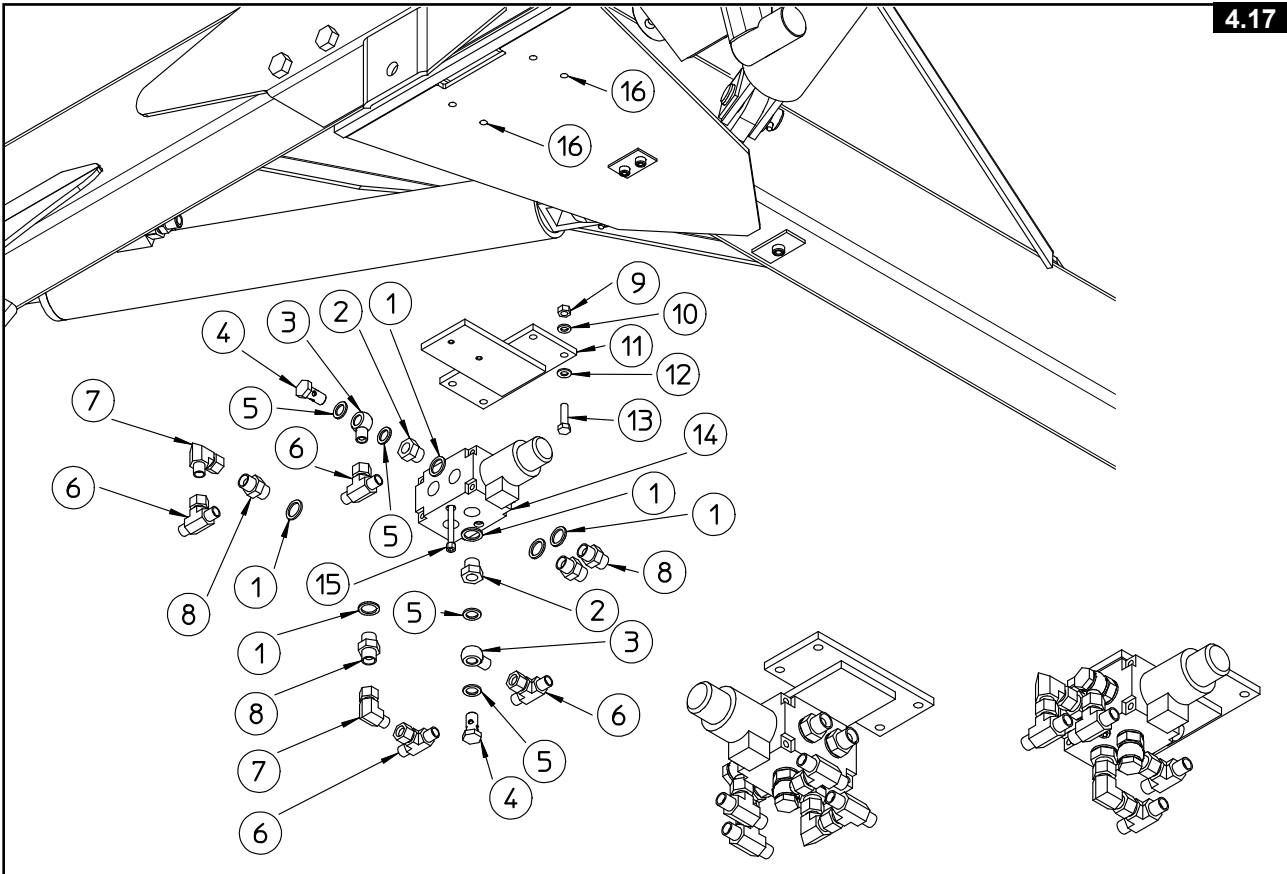

**STEP 20** - With reference to Fig. 4.17 carry out the operations in the following order:

- 1) Mount the fittings on the valve (14) as shown in the figure.
- 2) Attach the valve (14) to the bracket (11) with bolts (15).
- 3) Fasten the assembly obtained to the machine at holes (16) in the frame using bolts (13), nuts (9) washers (12) and split washers (10).

Pos.	Qty.	Description
1	6	WASHER 3/8" BONDED
2	2	REDUCTION MF 3/8"M-1/4"F
3	2	THREADED MALE EYE 1/4"
4	2	PERFORATED HOLLOW SCREW FITTING 1/4"
5	4	WASHER 1/4" BONDED
6	4	"T" FITTING 1/4" M-F. SWIVELING -
7	2	ELBOW FITTING 90° M-F 1/4" SWIVELING
8	4	REDUCTION NIPPLE 3/8" GAS - 1/4"
9	4	NUT M 8 (5/16") DIN 980
10	4	SPLIT WASHER $\varnothing$ 8.4 ( $\varnothing$ 5/16") DIN 127B
12	4	FLAT WASHER $\varnothing$ 8.4 ( $\varnothing$ 5/16") DIN 125A
13	4	BOLT M 8 X 30 (5/16"x1"11/64) DIN 931 8.8
14	1	FLOW DIVERTER, ELECTRIC 3/8"
15	2	BOLT M 6 X 50 (15/64"x2") DIN 912 8.8



**STEP 21** - With reference to Fig. 4.18 (right side), carry out the operations in the following order:

- 1) Attach the throttled nipple (4), the eye fitting (2), washer (1) to the valve (5).
- 2) Attach the regular (not throttled) nipple (6) and washer (1) to the valve (5).
- 3) Attach the assembly thus obtained on the boss on the rake arm fold-up cylinder shown in the figure using the bolt (3) and washers (1).
- 4) Repeat the same operation on the other side of the machine.

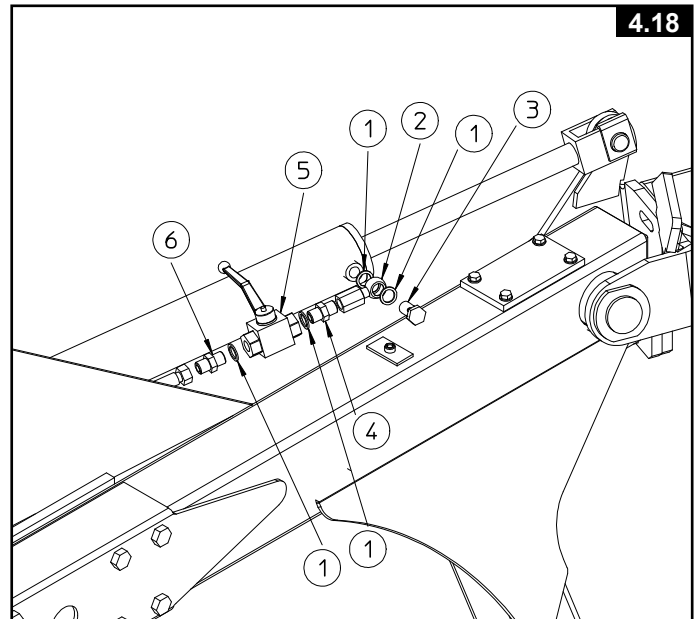

Pos.	Qty.	Description
1	8	WASHER 3/8" BONDED
2	2	EYE FITTING 3/8"
3	2	PERFORATED SCREW FITTING 3/8"
4	2	THROTTLED NIPPLE 3/8" - 3/8"
5	2	VALVE 3/8"
6	2	NIPPLE 3/8" - 3/8"

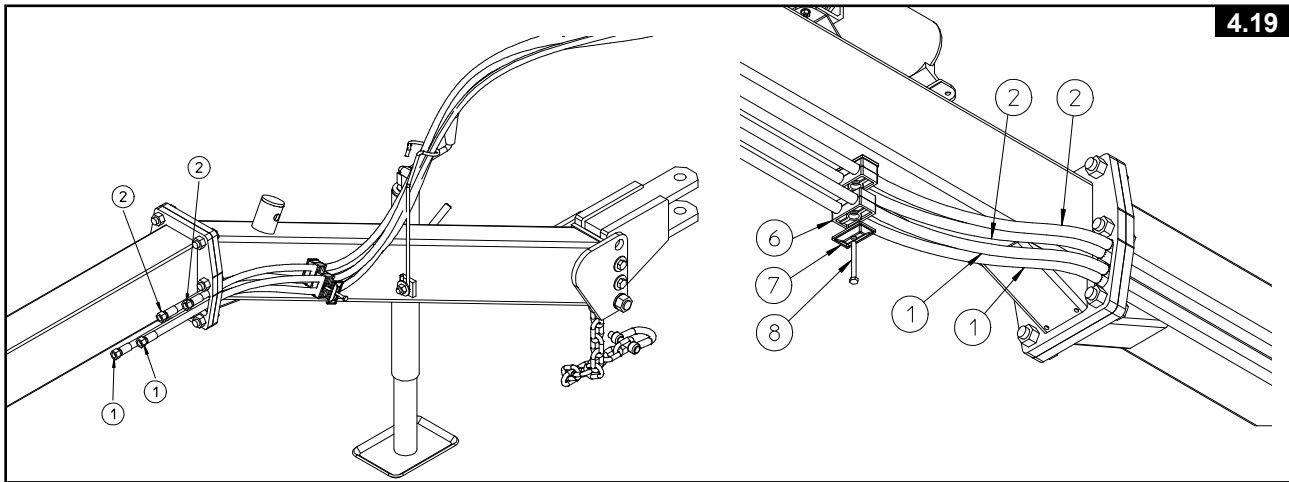

**STEP 22** - With reference to Fig. 4.19, carry out the operations in the following order:

- 1) Insert the hydraulic hose pairs (1) and (2) in the slot of the flange on the inclined drawbar as shown in the figure, from the side of the 1/4" male threaded fitting, paying attention to the arrangement of the pairs of hoses, so as to avoid having difficult crossing problems later on.
- 2) In Fig. 4.20, on the opposite side of the hydraulic hoses (1) and (2) there is a 1/2" male fitting (3) on which to place a 1/2" washer (4) and screw on the quick coupling (5) for the tractor valve.

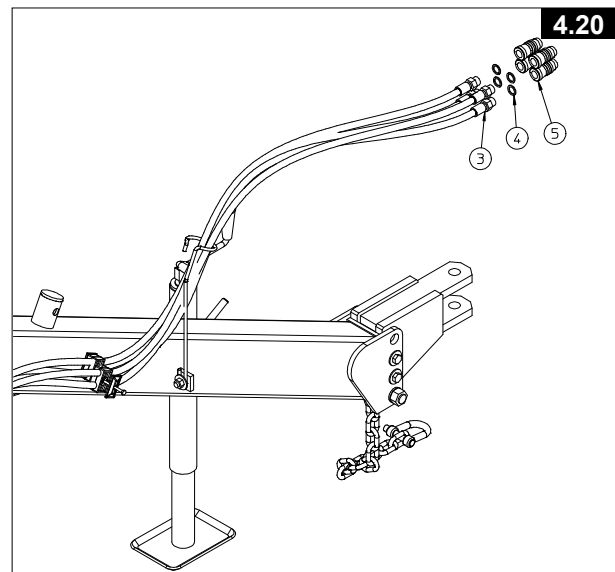

Pos.	Qty.	Description
1	2	HOSE L.5850mm (19'2"5/16) FD 1/4"-MD 1/2"
2	2	HOSE L.6000mm (19'8"7/32) FD 1/4"-MD 1/2"
4	4	Washer 1/2"
5	4	Quick coupling
6	8	DOUBLE SEMI-COLLAR $\varnothing 16$ ( $\varnothing 5/8$ ")
7	2	COLLAR PLATE
8	2	BOLT TE M 8 X 60 (5/16"x2"23/64) DIN 931 8.8

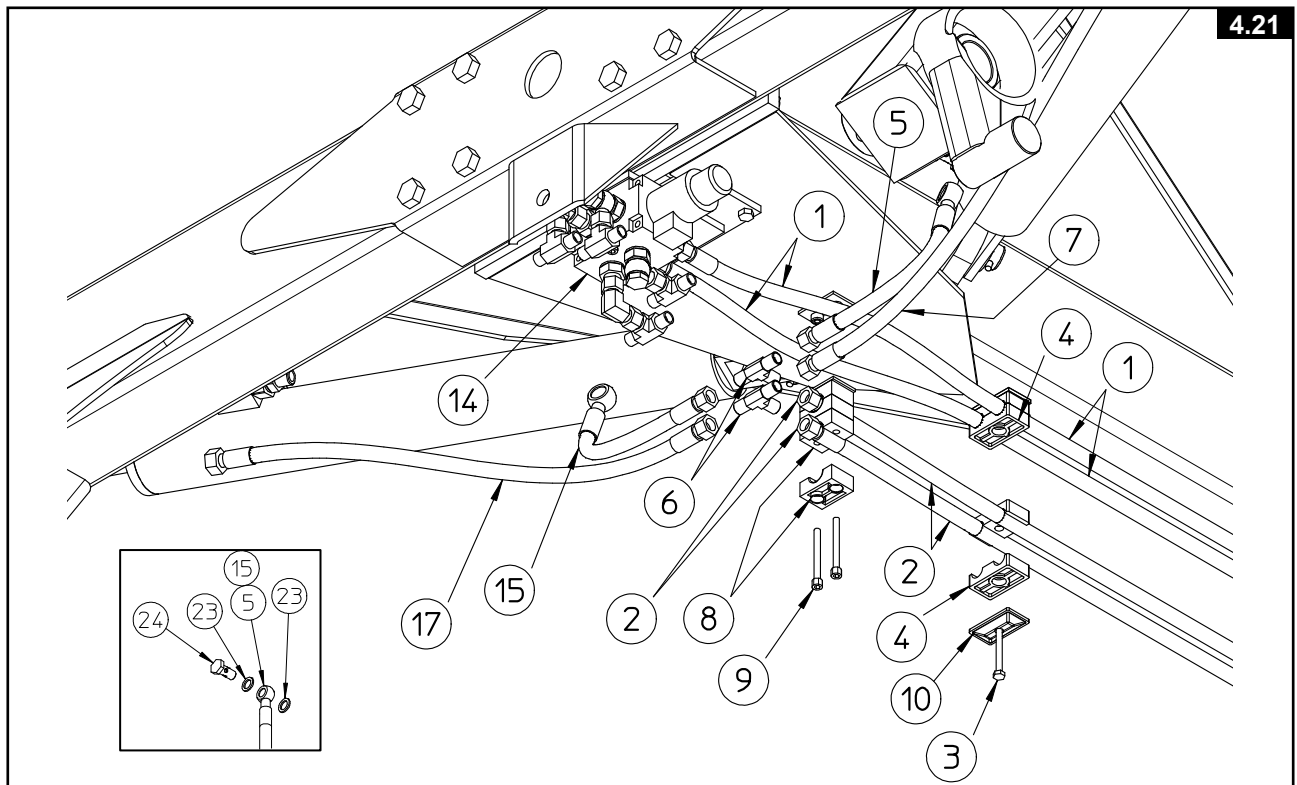

**STEP 23** - With reference to Fig. 4.21, carry out the operations in the following order (see also Fig. 4.24, the result of the completed assembly):

- 1) Secure the pair of hoses (1) length 6000mm (19'8"7/32) and hoses (2) length 5850mm (19'2"5/16) in the supports (4) without tightening the bolts.
- 2) Screw the T fittings (6) onto the hoses (2) before inserting them in the blocks (8).
- 3) Secure the pair of hoses (2) in the supports (8) without tightening the bolts. Pay attention to the crossed arrangement of the pair of hoses (2) in going from supports (4) to supports (8).
- 4) Screw the hoses (5) and (7) to the pair of T fittings (6) following the alignments shown in the figure.
- 5) Extend the hose (1) on the right side of the machine up to the valve (14) having it pass in between hoses (5) and (7) and screw it onto the right fitting of the valve (14). Screw the hoses (15) and (17) to the pair of T fittings (6) following the alignments shown in the figure.
- 6) Extend the hose (1) on the left side of the machine up to the valve (14) having it pass in between hoses (15) and (17) and screw it onto the left fitting of the valve. The blocks (8) must be in between hoses (1).
- 7) Connect the remaining end of the hose (5) with screw (24) and washer bonded (23) to the right fold-up cylinder and the hose (7) to the valve of the right fold-up cylinder.
- 8) Repeat the same operation on the other side of the machine with the hoses (15) and (17) to the left fold-up cylinder.

Pos.	Qty.	Description
1	2	HOSE L.6000mm (19'8"7/32) FD ¼"-MD ½"
2	2	HOSE L.5850mm (19'2"5/16) FD ¼"-MD ½"
3	1	BOLT TE M 8 X 60 (5/16"x2"23/64) DIN 931 8.8
4	4	DOUBLE SEMI-COLLAR ø16 (ø5/8")
5-15	2	HOSE L. 475mm (18"11/16) FD ¼"-OC 3/8"
6	2	T FITTING ¼" male-male-male
7-17	2	HOSE L. 720mm (28"11/32) FD ¼"-FD 3/8"
8	4	SINGLE SEMI-COLLAR ø18 (ø45/64")
9	2	BOLT M 6 X 60 (15/64" x2"23/64) DIN 912 8.8
10	1	COLLAR PLATE
22	4	BONDED WASHER 3/8"
23	2	SCREW 3/8"

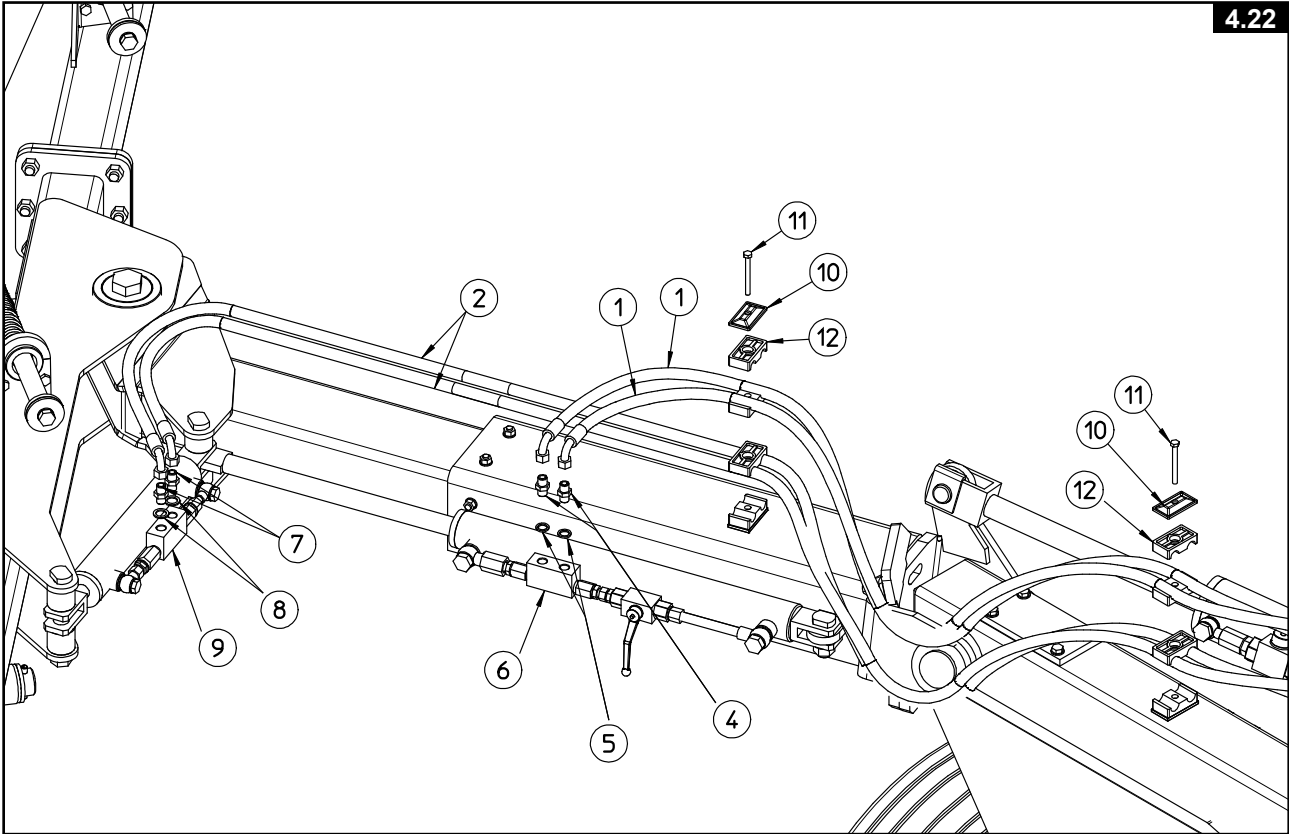

**STEP 24** - With reference to the figure, carry out the operations in the following order:

- 1) Secure the pair of hoses (2) length 2600mm and hoses (1) length 2200 in the supports (12) without tightening the bolts. Take into account the extension stroke of cylinder (6) when the blocks (12) are fastened. Pay attention to the arrangement of the hoses in pairs as shown in the figure.
- 2) Connect hoses (2) to cylinder (9) with fittings (7) and washers (8).
- 3) Connect hoses (1) to cylinder (6) with fittings (4) and washers (5).
- 4) Repeat the same operations on the other side of the machine without tightening the bolts of blocks (12).

Pos.	Qty.	Description
1	4	HOSE L. 2200mm (7'2"39/64) F90 ¼"-FD ¼"
2	4	HOSE L. 2600mm (8'6"23/64) F90 ¼"-FD ¼"
4-7	8	NIPPLE ¼" - ¼"
5-8	8	WASHER ¼" BONDED
10	4	COLLAR PLATE
11	4	BOLT M 6 X 60 (15/64"x2"23/64) DIN 912 8.8
12	16	DOUBLE SEMI-COLLAR ø16 (ø5/8")

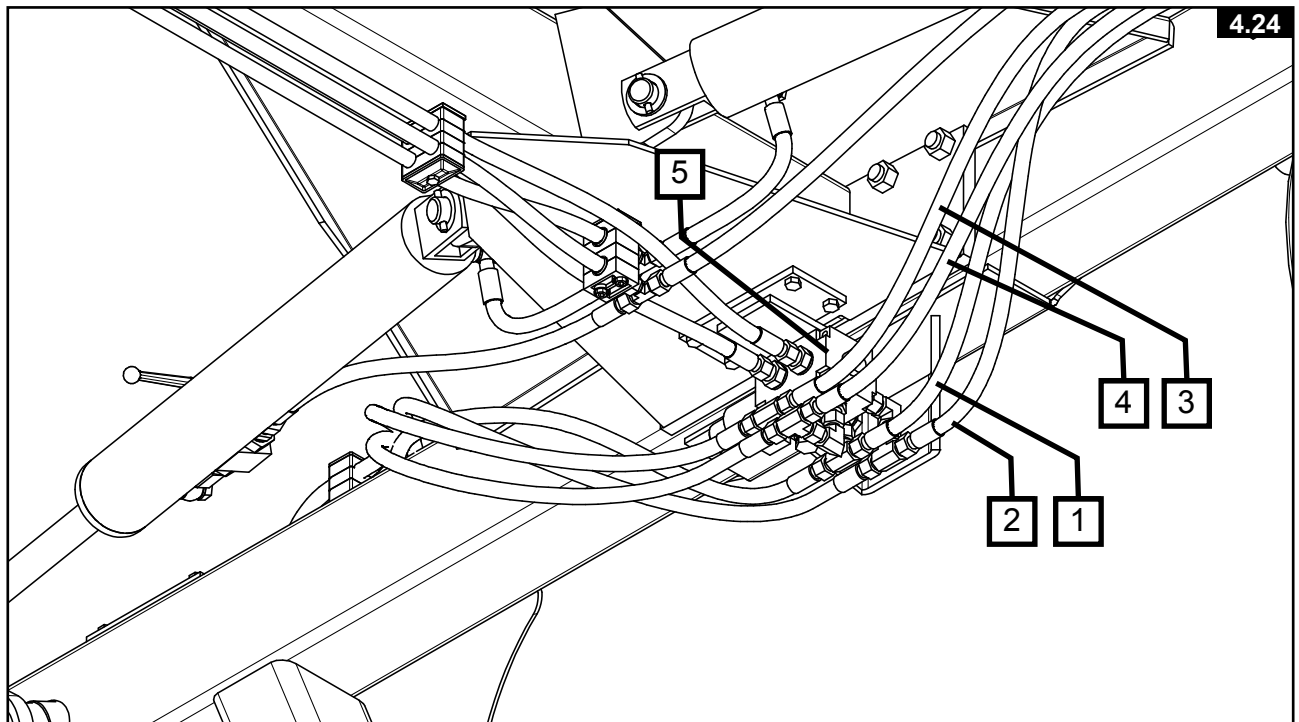
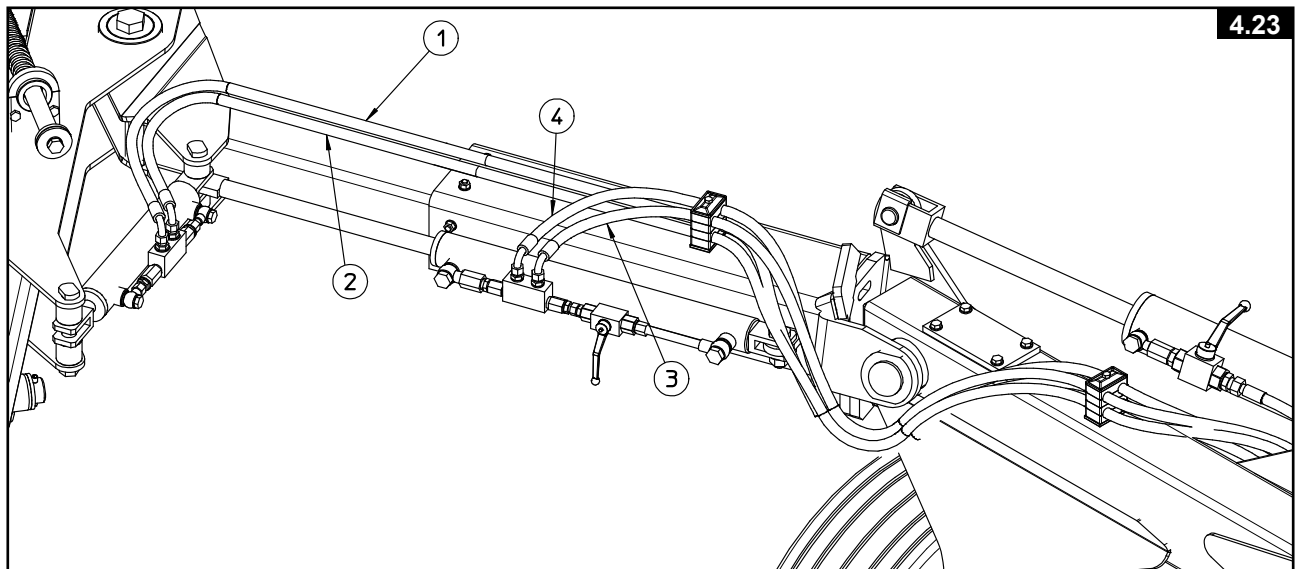

**STEP 25** - With reference to Fig. 4.23 and 4.24, carry out the operations in the following order:

- 1) Screw the hose fittings (1), (2), (3) and (4) into the valve (5) as shown in Fig. 4.24. The hoses (1), (2), (3) and (4) must be the same in Fig. 4.23, otherwise the hydraulic system will malfunction.
- 2) Repeat the same operations on the other side of the machine.

When all of the assembly is completed, check to make sure that the connections have been properly made. Lastly, fasten the hoses with the collars.

## 4.6 ELECTRICAL SYSTEM ASSEMBLY

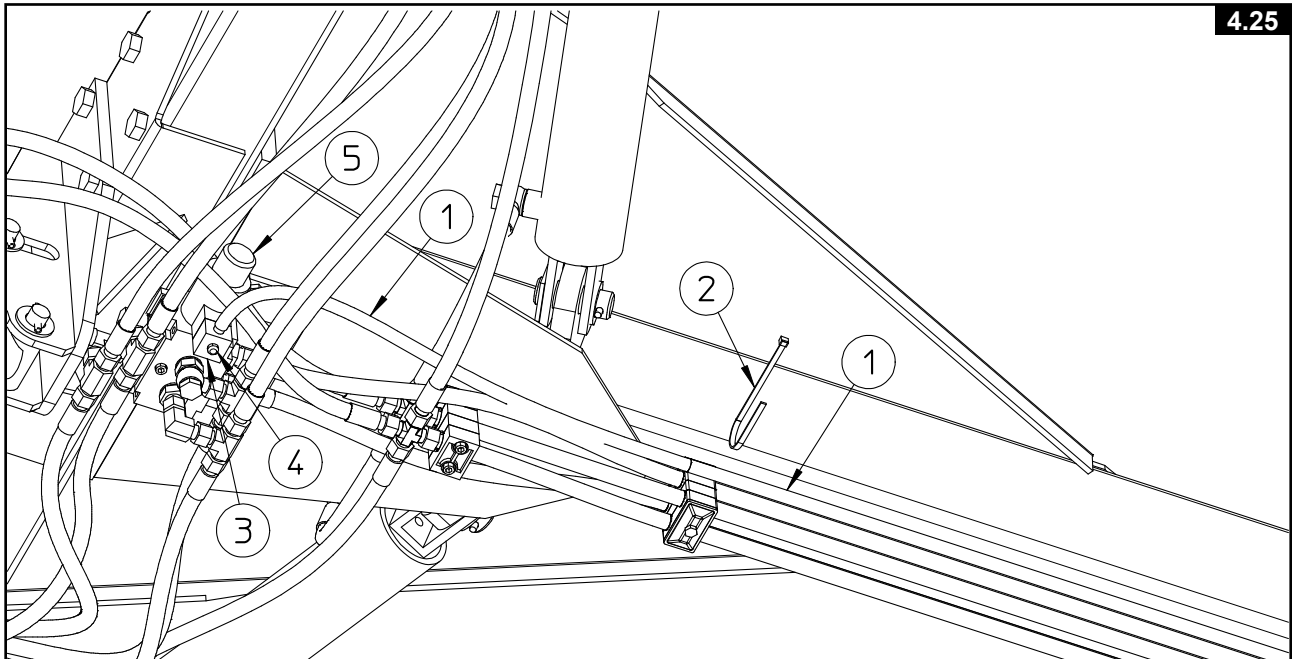

With reference to Fig. 4.25 and 4.26, carry out the operations in the following order:

- 1) Extend the electric cable (5) in Fig.4.26 along the machine drawbar.
- 2) Screw connector (3) into the valve (5) with the bolt (4) in Fig.4.25 passing through the hydraulic hoses as shown in the figure.
- 3) Fasten the cable (1) with the bands (2) along the hydraulic hoses of the machine drawbar.
- 4) Place the control box (1) in Fig. 4.26 in the tractor cab using the bracket (3).
- 5) Tighten the knobs (2) after having suitably oriented the control box.
- 6) Connect the multi-pin plug (7) to the tractor plug.

**When the machine is detached from the tractor, the connector (4) of cable (5) can be disconnected, leaving the control box permanently in the tractor cab.**

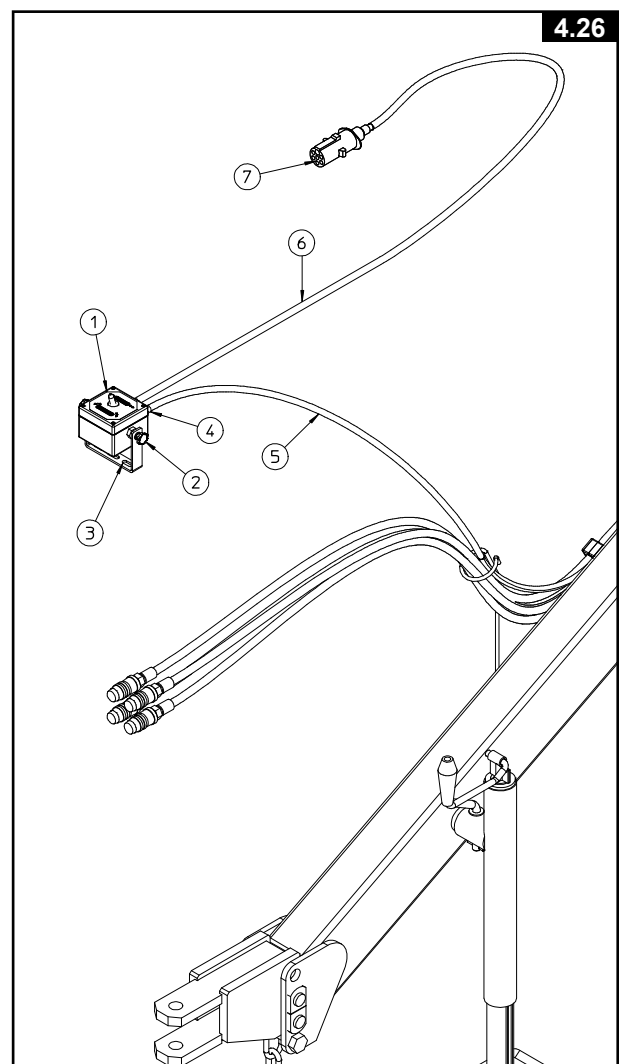

## 4.7 CENTER RAKE WHEEL KIT (OPTIONAL)

The center rake wheel kit is used to move the hay in the central part of the windrow.

The hydraulic cylinder is operated in parallel with the raising of the rake arms, therefore no further operations are necessary.

The center rake wheel normally moves very fast when working properly.

The compensating spring must be adjusted with the two nuts on the bolt, so as to obtain the right pressure on the ground according to the desired working conditions.

- Tighten the nuts (20) of the bolt (19) in Fig.4.27 to decrease the pressure on the ground.
- Loosen the nuts (20) of the bolt (19) in Fig.4.27 to increase the pressure on the ground.

If the working conditions do not require the use of the center rake wheel, close the valve (5) in Fig.5.26 after having positioned the rake wheel arm in the raised position.

To lock the center rake wheel kit:

- 1) Activate the tractor hydraulic system and raise the fold-up arms up to the stops.
- 2) Turn off the tractor motor and remove the key.
- 3) Wait until all moving parts have stopped.
- 4) Close the valve (5) in Fig.4.28

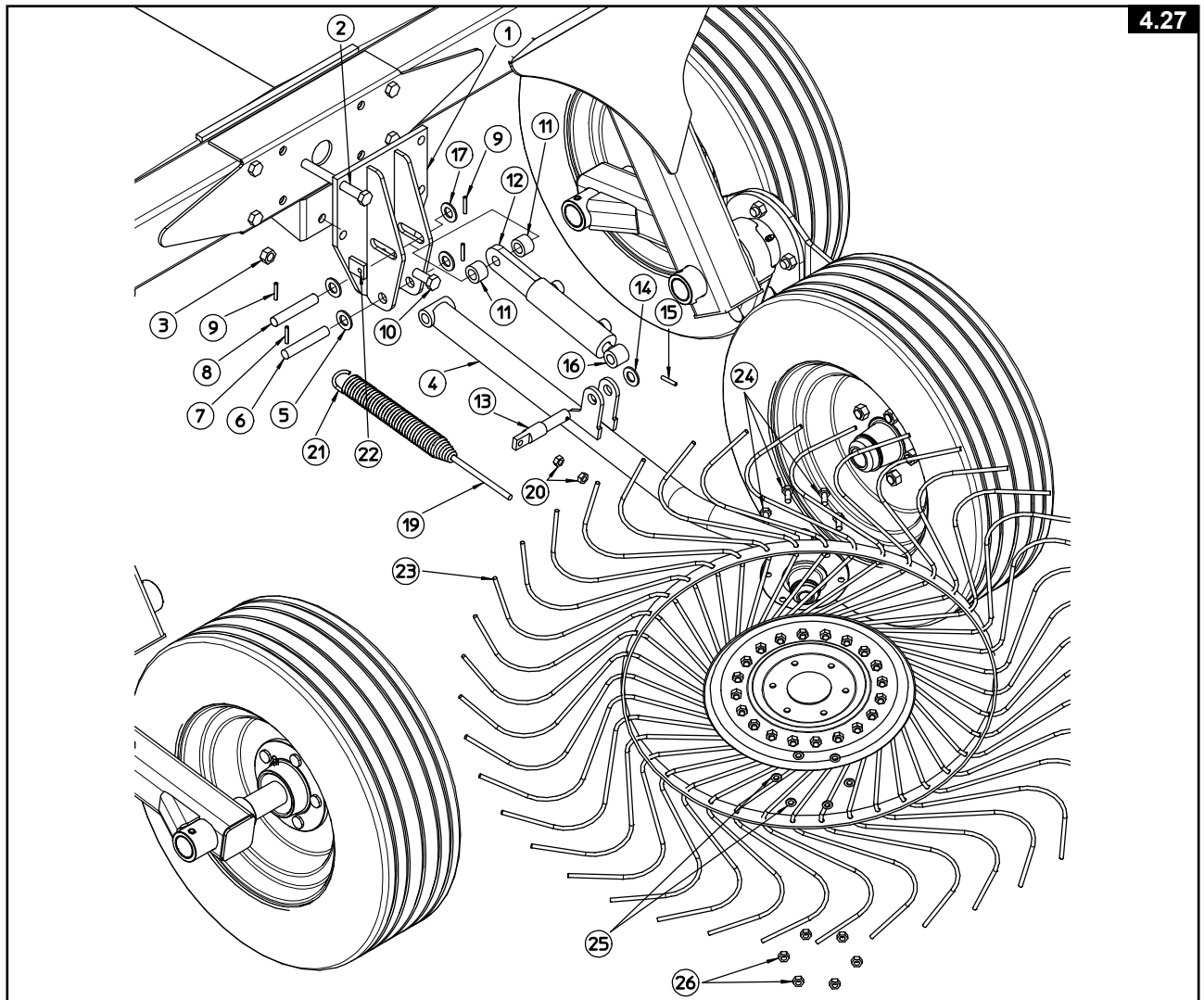

4.27

---

To assemble the center rake wheel kit, proceed as follows (Fig. 4.27):

- 1) Remove the four bolts that connect the drawbar at the four holes in the plate (1).
- 2) Fasten the plate (1) using the long bolts (2) and the bolt (10) and nuts (3).
- 3) Attach the arm (4) to the plate (1) using the pin (6), washers (5) and spring pins (7).
- 4) Attach the hydraulic cylinder (12) with the spacers (11) to the plate (1), using the pin (8), washers (17) and spring pins (9).
- 5) Connect the arm (4) to the cylinder at hole (16) with the milled pin (13), washer (14) and spring pin (15).
- 6) Insert the spring hook (21) into the hole (22) in the plate (1).
- 7) Insert the bolt (19) into the hole of the milled pin (13).
- 8) Screw the nuts (20) onto the bolt (19), until a few millimeters of the threading protrude (about 3-4mm).  
The tension of the spring must be adjusted according to the desired pressure of the rake wheel on the ground.
- 9) Fasten the rake wheel (23) to the arm (4) using the bolts (24), washers (25) and nuts (26).

Pos.	Qty.	Description
2	4	BOLT TE M16 X150 (5/8"x5"57/64) DIN 931 8.8
3	5	NUT M16 (5/8") DIN 980
5-14-17	5	FLAT WASHER $\varnothing$ 21 ( $\varnothing$ 13/16") DIN 125A
6-8	2	PIN $\varnothing$ 20 ( $\varnothing$ 25/32")
7-9-15	5	SPRING PIN $\varnothing$ 6x35 (15/64"x1"3/8) DIN 1481
10	1	BOLT M16x40 (5/8"x1"9/16) DIN 933 8.8
11	2	SPACER $\varnothing$ 20.5/34-23 (25/32"-1"21/64x57/64")
13	1	PIN $\varnothing$ 20/25 ( $\varnothing$ 25/32"-1")
20	2	NUT M10 (25/64") DIN 934 8
24	6	BOLT M10x25 (25/64"x1") DIN 933 8.8
25	6	SPLIT WASHER $\varnothing$ 10.5 ( $\varnothing$ 26/64") DIN 127B
26	6	NUT M10 (25/64") -DIN 934



#### 4.7.1 CENTER RAKE WHEEL KIT HYDRAULIC SYSTEM ASSEMBLY

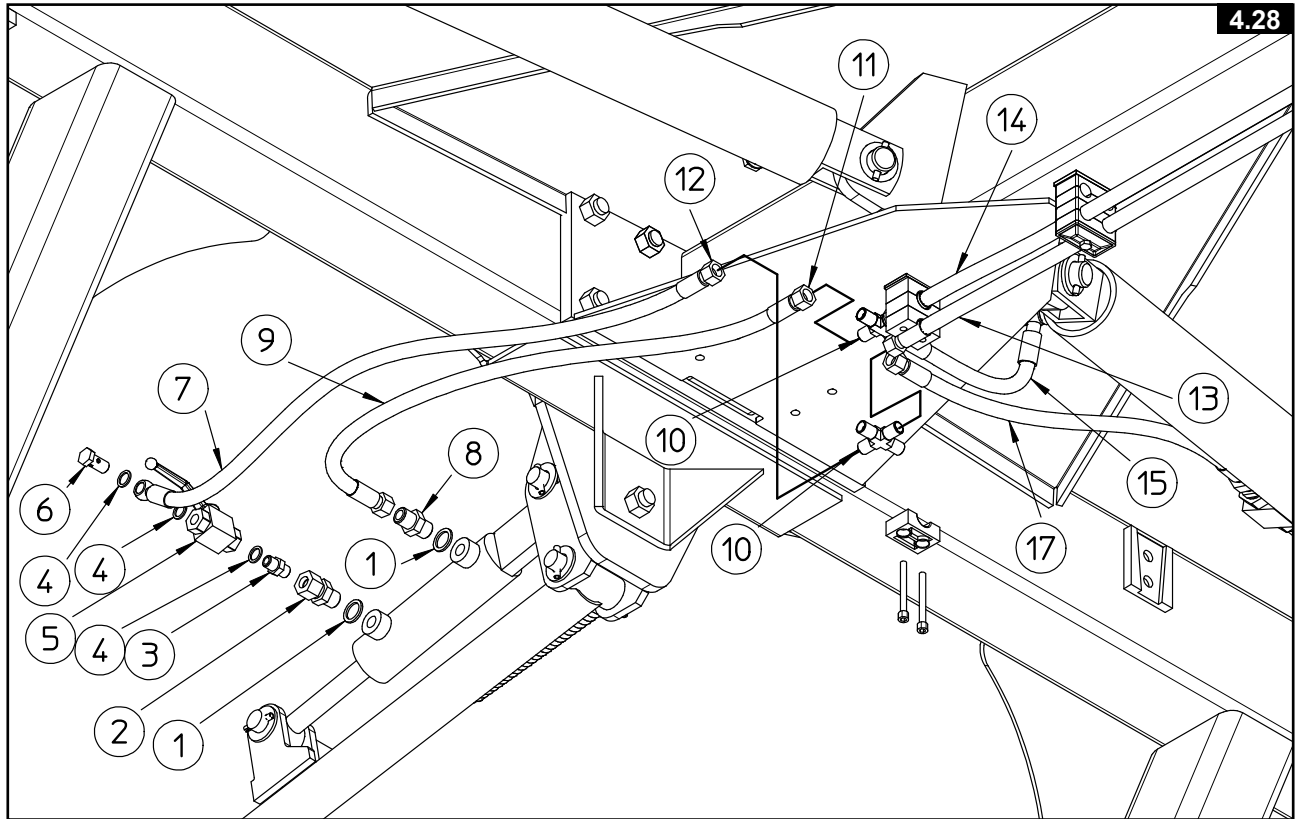

To assemble the center rake wheel kit hydraulic system, refer to Fig. 4.28 and proceed as follows (see also Fig. 4.29 , the result of the completed assembly):

**Attention: before proceeding, make sure that the hydraulic system is not under pressure. Wear personal protective equipment (gloves, goggles, etc.). When loosening the fittings, proceed with care and caution.**

- 1) Remove the T fittings and replace them cross fittings (10).
- 2) Connect the hose (9) from the 3/8" female fitting side to the boss at the base of the cylinder using the washer (1) and throttling nipple (8). Do not fully tighten at this stage.
- 3) Connect the 1/4" female side of the short hose (9) to the T fitting (10), and the 3/8" female fitting to the throttling nipple (8). Position correctly the hose (9) so that it does not get deformed or crushed when the cylinder is operating. Once this is done, tighten all the various components that had been left un-tightened earlier.
- 4) Fasten the fitting (2) to the upper boss on the cylinder, with the washer (1).
- 5) Connect the valve (5) to the adaptor nipple (3) with the washer (4).
- 6) Screw the valve assembly just formed to the swiveling fitting (2).
- 7) Put the lever of the valve (5) in the open position so that it won't get in the way during the assembly. Screw the fitting (12) of the long hose (7) onto the T fitting (10) and the eye fitting to the valve (5) with the washers (4) and the hollow screw (6). Do not fully tighten screw (6) at this stage (6).
- 8) Now correctly position the hose (7) so that it does not get deformed or crushed when the cylinder is operating, then fully tighten the screw (6).

Pos.	Qty.	Description
1	2	WASHER 3/8" BONDED
2	1	STRAIGHT FITTING M-F SWIVELING 3/8"
3	1	REDUCTION NIPPLE 3/8" - 1/4"
4	3	WASHER 1/4" BONDED
5	1	VALVE 1/4"
6	1	PERFORATED SCREW FITTING 1/4"
7	1	HOSE L. 730mm (28"47/64) FD 1/4"-OC 1/4"
8	1	NIPPLE 3/8"-3/8" THROTTLED
9	1	HOSE L. 640mm (25"3/16) FD 1/4"-FD 3/8"
10	2	CROSS FITTING, 1/4"

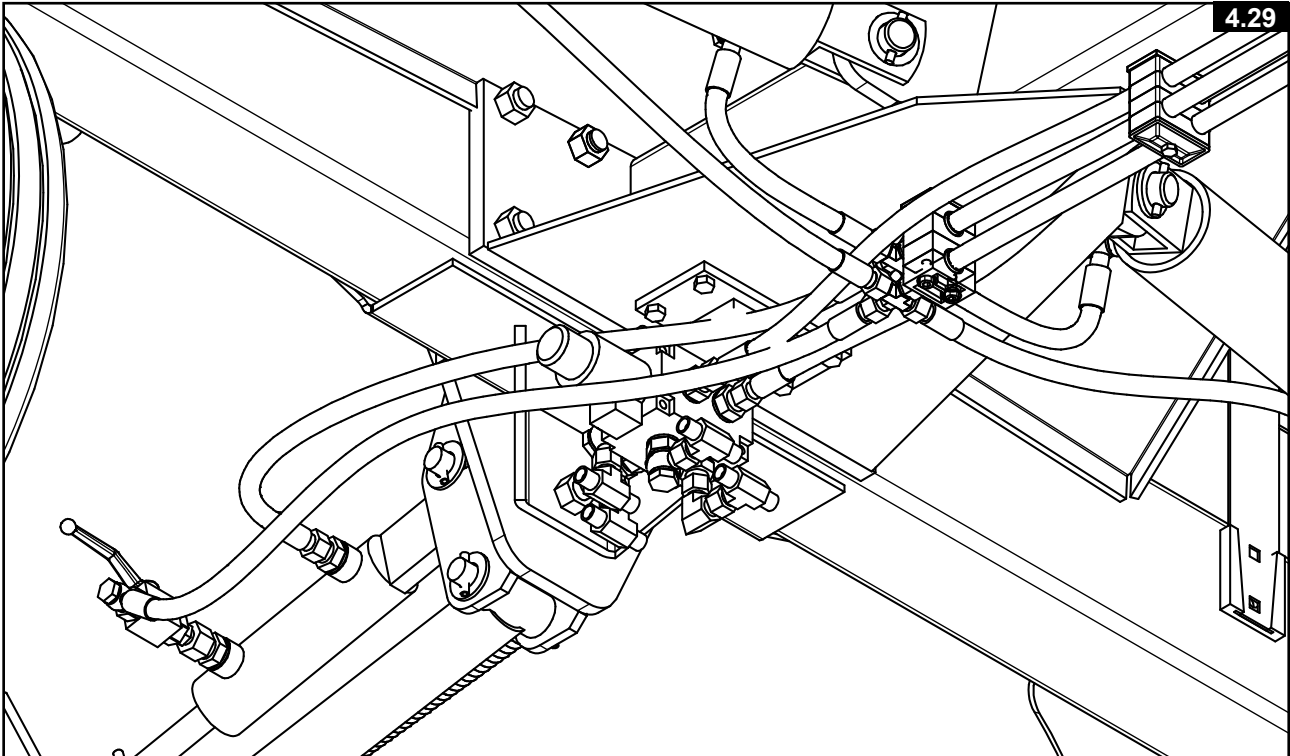

## 4.8 ASSEMBLY OF CONVERSION KIT FROM QRX12 TO QRX14

To convert the machine from 12 to 14 rake wheels add the extension on the extreme position of wheels support of the 12 rake wheels machine.

With reference to fig. 4.30 carry out the operations in the following order:

- 1) Mount the extension (22) with the front section (18) and secure with screws (19) and nuts (18).
- 2) Insert the plug (21) in the extension (22).
- 3) Repeat the same procedure on the other side of the machine.

Item (19): 6+6 screws M12x35 (15/32"x1,3") DIN 933

Item (18): n°6+6 nuts M12 (15/32") DIN 980

Item (21): n°2 plugs

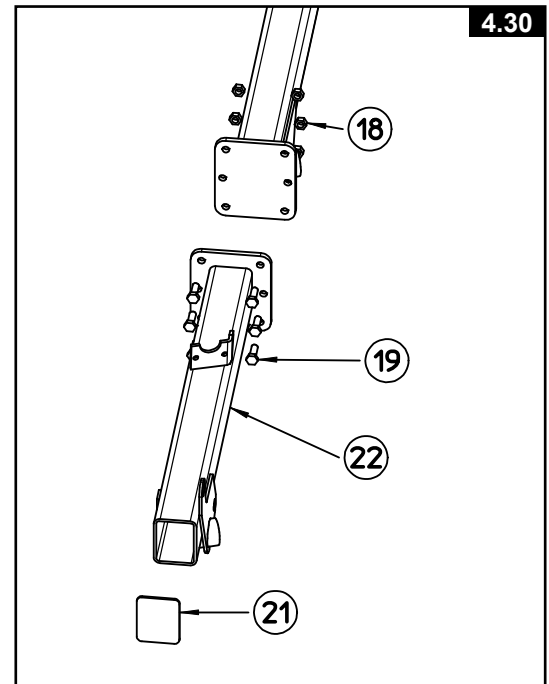

**Before continuing the installation note:**

**The pair of arms (right and left) with locking hole (ref.9 fig. 4.31) is present in the assembly kit.**

With reference to fig. 4.31 carry out the operations in the following order:

- 1) Put the filter locking pin (10) on the new section (12) in the position shown, by reversing the operations in fig. **Errore. L'origine riferimento non è stata trovata.**
- 2) Insert the plastic bushings (2) into the pockets (11) of the rake sections (12).
- 3) Insert the arm (8) **with locking hole** to the section 12 and secure with the washer (3) and spring pin (4).
- 4) Install the nipple (6) M6 into the threaded hole of the bushings (11).
- 5) Repeat the same procedure on the other side of the machine.

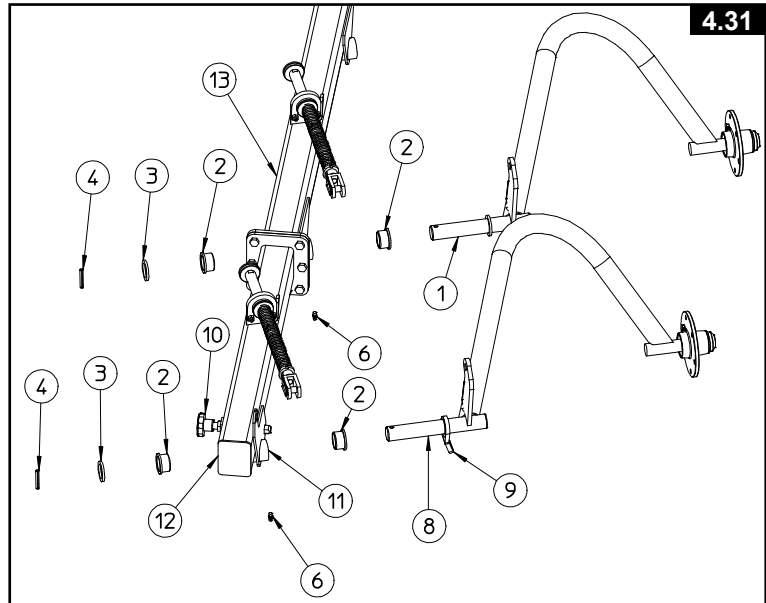

Item (2): n° 4 plastic bush  $\varnothing 35-42 \times 26$  ( $\varnothing 1\frac{3}{8}-1\frac{41}{64} \times 1\frac{1}{64}$ )

Item (3): n° 2 washers  $\varnothing 35-50 \times 5$  ( $\varnothing 1\frac{3}{8}-1\frac{61}{64} \times 3/16$ )

Item (4): n° 2 spring pins  $8 \times 50$  ( $\varnothing 5/16 \times 1\frac{61}{64}$ ) DIN 1481

Item (6): n° 2 grease nipple M6 (15/64")

- 1) Loosen all the blocks (5) which support the pipelines (1), (2), (3) end (4) for their entire length.
- 2) Remove the hoses (1) e (2) from the fitting "T" and the hoses (3) and (4) from the valve.
- 3) Install the four extension hoses of the kit in points (1) (2) (3) and (4) as shown in figure.

Item (1-2-3-4): n° 4 hoses lg.900 (35"1/2)

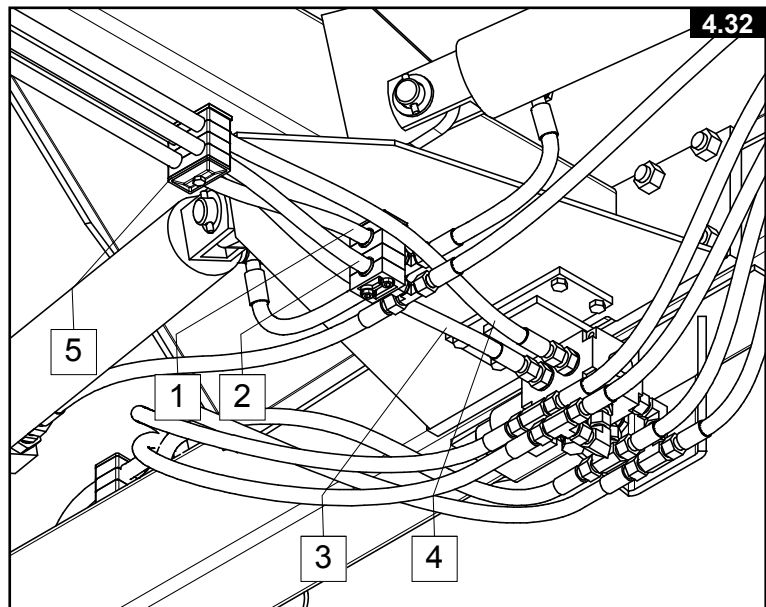

## 4.9 GREASING POINTS

After assembly is completed, lubricate the joints and sliding parts of the machine before starting any movement.

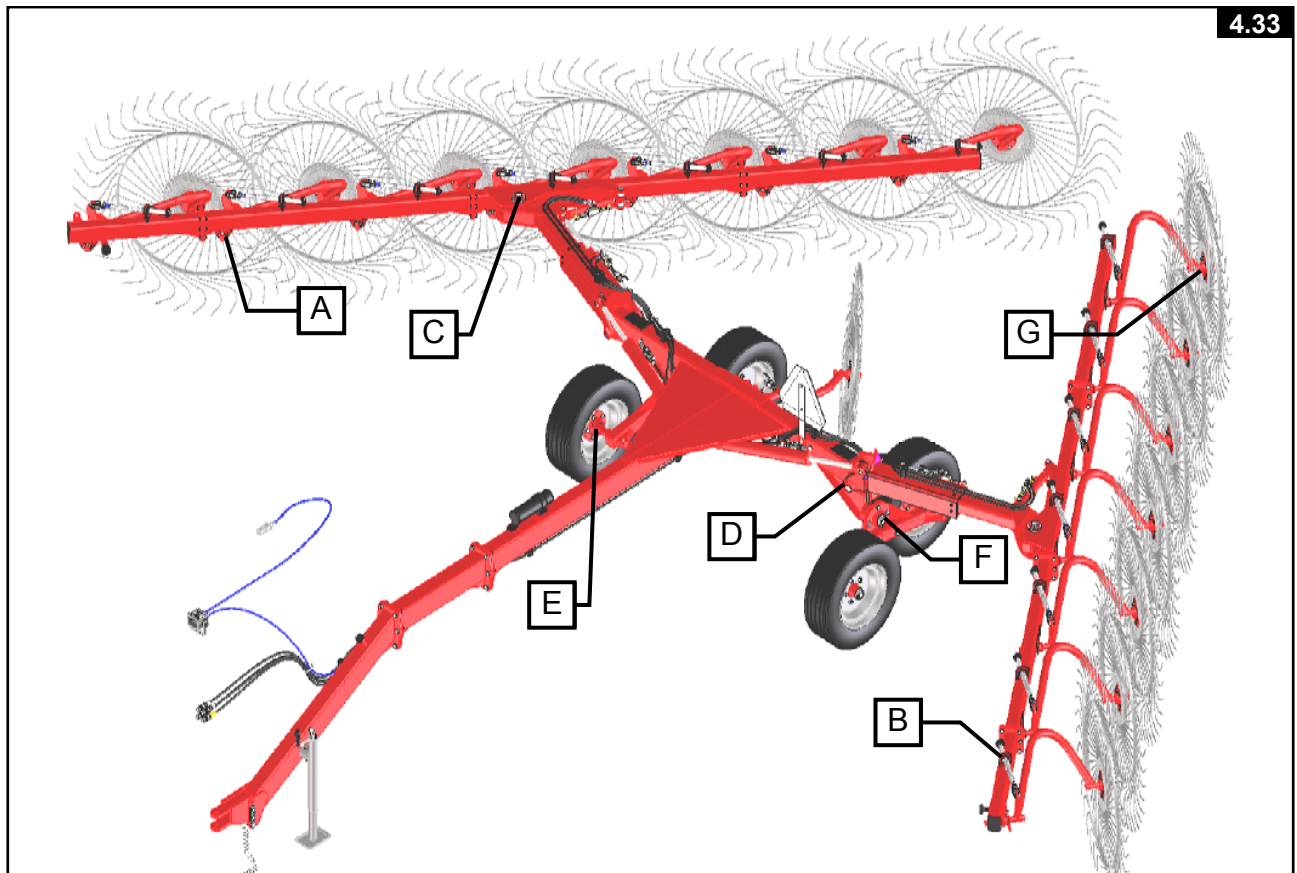

Lubricate after a given period of work.

Every 25 (twenty-five) hours (Fig. 4.33):

- Pivot pins of the rake wheel arms (A)
- Rake wheel arm suspension spring assemblies (B)
- Pins (C), (D)

Every 40 (forty) hours (Fig. 4.33):

- wheel hubs (E), tandem axle hub (F), rake wheel hubs (G)

At the beginning of each season:

- Read the operator's manual.
- Check the tire pressure.
- Lubricate all greasing points.
- Check the tightness of the wheel nuts with a tightening torque of 120 ft. lbs. (16.3 daNm)

## SECTION 5 ADJUSTMENT, PREPARATION AND USE

The machine must be adjusted according to the specific work requirements. Different types of adjustments are described here, so you can choose the one that best suits your work needs. Before connecting the machine, make sure that it cannot accidentally start moving (insert chocks under the wheels).

### 5.1 HITCHING THE MACHINE TO THE TRACTOR

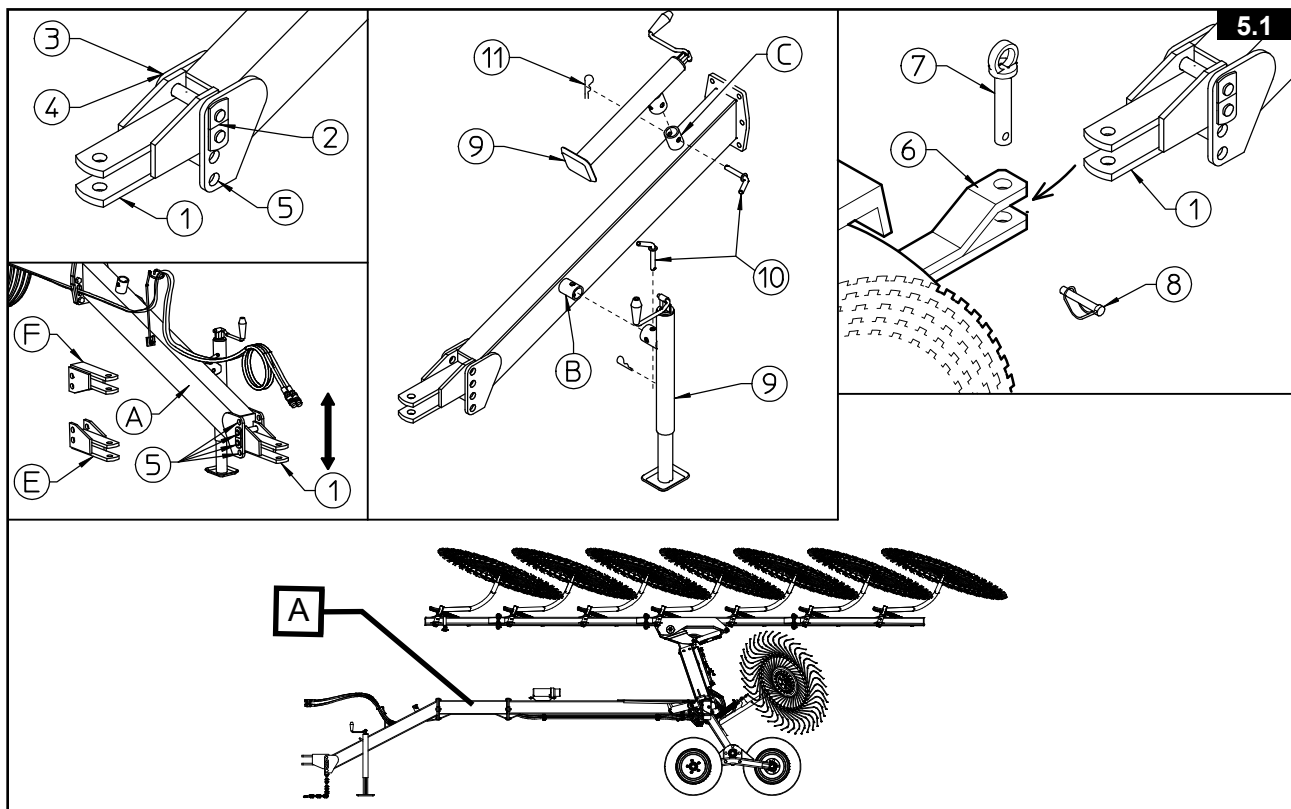

Carry out the operations in the following order (Fig. 5.1):

- 1) Check that the height from the ground of the drawbar hitch (1) and of the tractor hitch (6) are suitable for having the drawbar (A) parallel to the ground when it is hitched to the tractor. To adjust the drawbar, carry out operations 2) and 3).
- 2) Remove the pins (2) from the hitch (1), removing the washers (3) and bolts (4).
- 3) Set the hitch (1) in the desired position, moving it to the free holes (5), and fasten again with the pins, bolts and washers used previously. The hitch can be rotated from position (E) to position (F) to obtain the best position.
- 4) Connect the drawbar hitch (1) to the tractor hitch (6) with pins (7)-(8) of adequate shape and size.

**It is important to place the machine on flat ground. Always use extreme caution when reversing the tractor toward the machine.**

- 5) Remove the parking stand (9) from point (B), removing the clip (11) and the pin (10).
- 6) Move it to point (C), securing it in place with the pin (10) and the clip (11).
- 7) Check that the drawbar (A) is parallel to the ground.

Now check the functionality of the machine, remembering that this must be done in a suitable area and with no one within the operating range of the machine.

---

## 5.2 UNHITCHING THE MACHINE FROM THE TRACTOR



**DANGER !!!**



**Always park the machine on flat ground.**

Carry out the operations in the following order:

- 1) Block the machine with chocks under the wheels.
- 2) Disconnect the hydraulic and electrical lines.
- 3) Secure the hydraulic and electrical lines in the bracket.
- 4) Unhook the safety chain.



**DANGER !!!**



**Before removing the pin connecting the machine to the tractor, always keep the machine either with the arms folded all the way up to the stops, or put the arms in the lowered position with the rake wheels on the ground, to avoid having the machine unbalanced when unhitching it from the tractor.**

- 5) Remove the parking stand from the transport position.
- 6) Install the stand in the parking position.
- 7) Secure the stand in place with the pin with handle and clip.
- 8) Turn the parking stand crank until the foot touches the ground and continue cranking until the machine no longer pulls on the tractor hitch.
- 9) Remove the pin.

The machine is now unhitched.

When the machine is parked for long periods, it is recommended that the arms be folded up all the way, to eliminate pressure on the hydraulic circuit.

### 5.3 ELECTRIC SELECTOR

The hydraulic cylinders (B) and (D) in Fig. 5.2 make it possible to rapidly adjust the working width and windrow width from the tractor valve using the electric selector in Fig. 5.3 (angulation - extension).

To change the extension of the telescoping arm (A), move the tractor valve connected to the line of hoses of cylinders (B), after having selected the "EXTENSION" position on the remote control shown in Fig. 5.3.

To change the angle of the arm (C) move the tractor valve connected to the line of hoses of cylinders (D), after having selected the "ANGULATION" position of the remote control in Fig. 5.3.

**Changing the working angle results in the changing of the windrow width.**

**If the hydraulic movements on the right and left sides of the machine get slightly out of sync with each other, do a complete cycle of opening and closing over the entire stroke of the cylinders in question to restore the symmetry of the movements.**

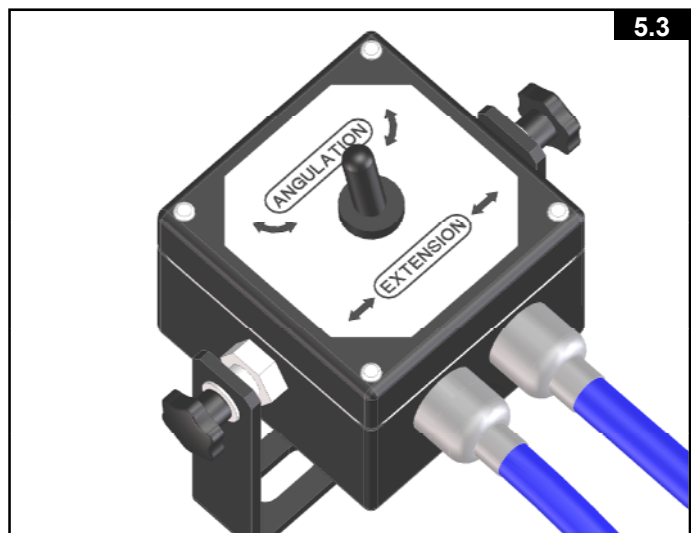
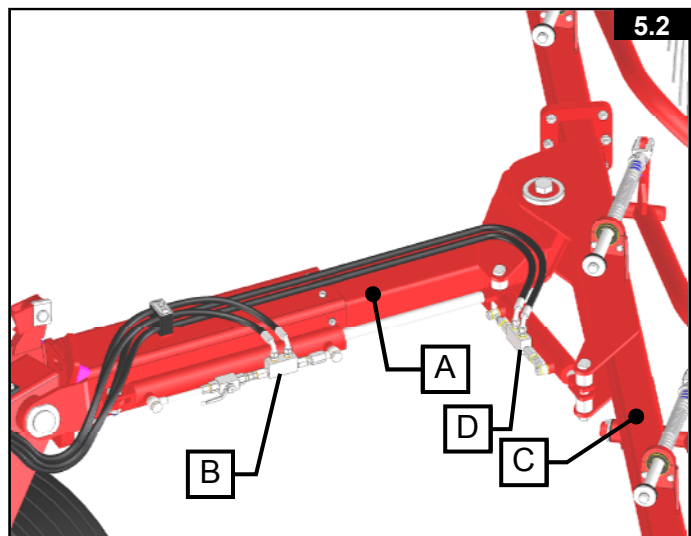



### 5.3.1 FUSE AND ELECTRICAL DIAGRAM

The fuse is located on one side of the control box and can be accessed by unscrewing the protective cap.

**Before replacing the fuse, check with expert personnel that there are no short circuit contacts in the electrical circuit in Figure 5.5.**

The cable for the solenoid valve has a connector with an LED light that turns on when current is passing through (Fig.5.4).

**The LED light will be damaged if the connections of the cables at the terminals of the connector are accidentally reversed (see diagram Fig.5.5)**

If the LED light on the solenoid connector does not turn on:

- 1) check that there is power at the tractor plug.
- 2) check that the fuse is good
- 3) the LED light is damaged

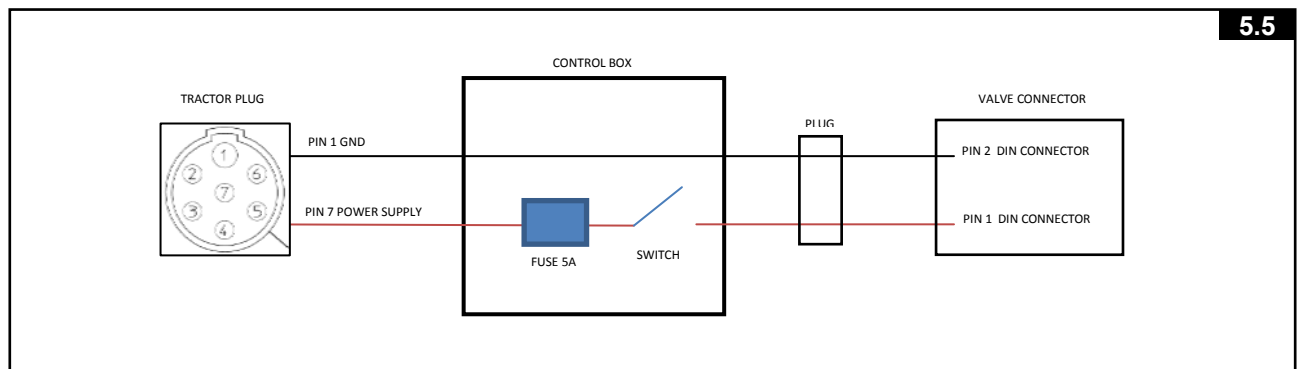
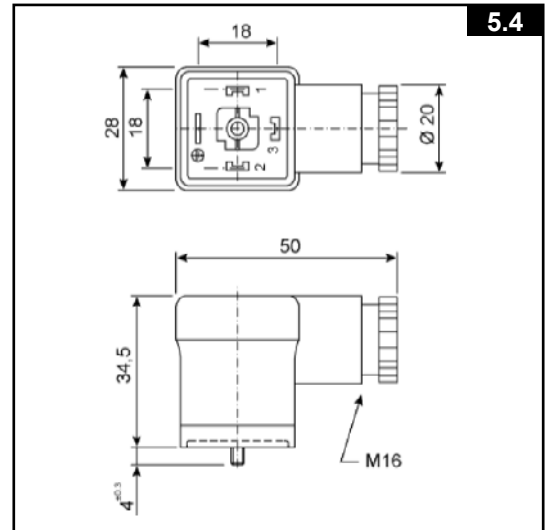

### 5.3.2 POWER SUPPLY CONNECTOR

The power supply connector of the tractor may vary depending on the model and country of origin.

The standard supplied is the 7-pin plug according to ISO 1185 as in fig.5.6.

Plug is available on request for 3-pin socket DIN 9680.

The replacement of the plug is possible by making attention to the arrangement of the electrical polarity as in fig. 5.6.

**The solenoid connector (Fig. 5.4) will be damaged if the connections of the cables are accidentally reversed (see diagram Fig.5.5)**

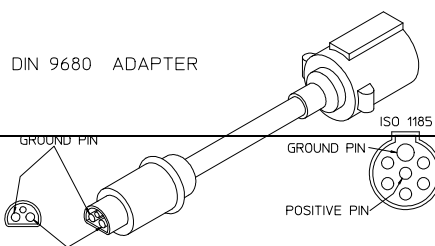
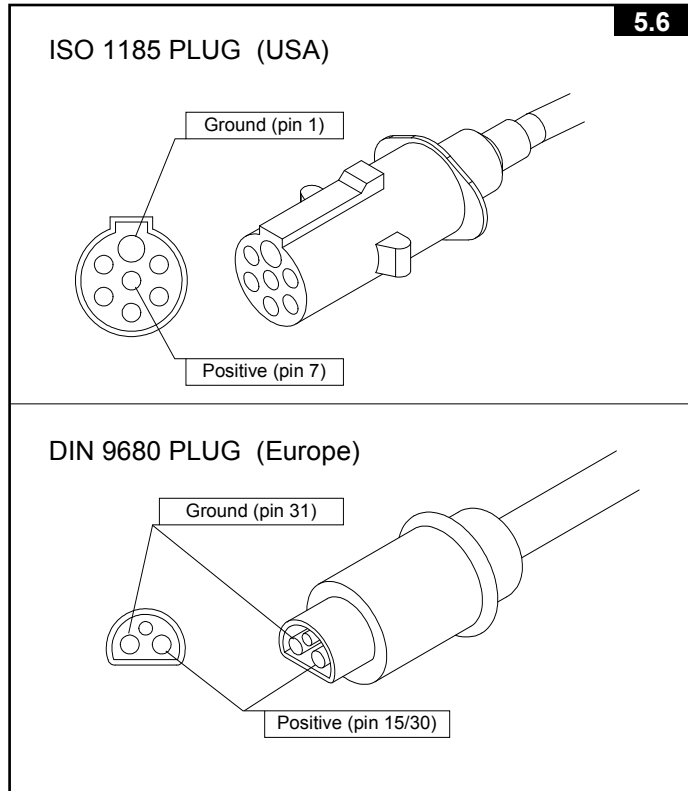

## 5.4 ROAD TRANSPORT



**When sections are raised, the shape of the hinges brings the weight towards the tractor and makes it possible to decrease the size of the machine.**

**Check carefully when raising the sections that the machine parts do not touch the tractor.**

Make sure during transport operations with some tractors, while steering or when moving over rough ground, that the sections do not touch the sides of the tractor, with the risk of causing damage to both machines. If there could be contact between the parts, it is recommended that the angle of the sections be increased by means of the angle cylinder, before raising the sections. This brings the sections farther away from the tractor and creates a situation of increased safety.



**When the rake arms are raised in the vertical position (Fig. 5.7), the telescoping arms A (Fig. 5.2) must always be fully retracted.**

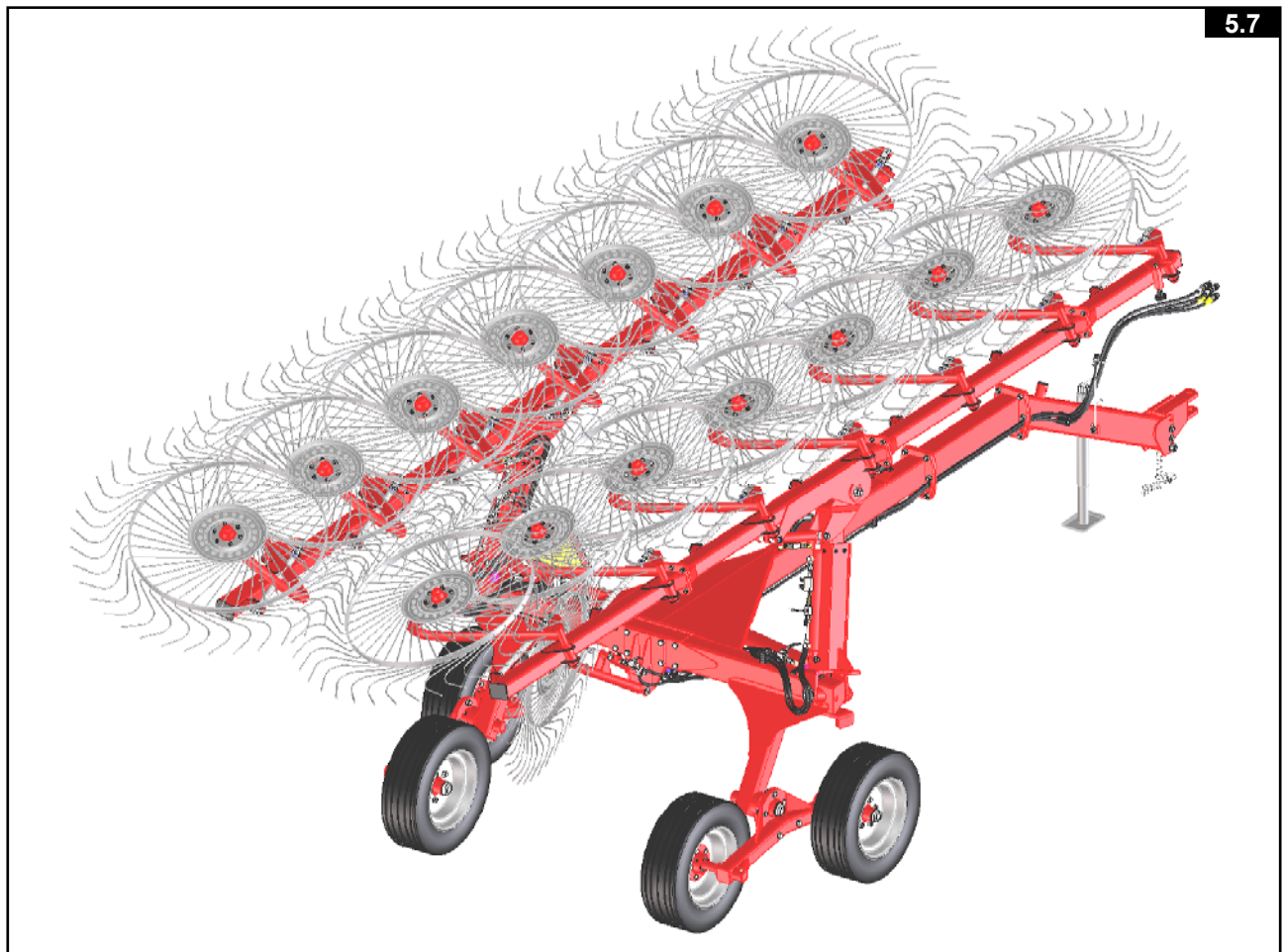

5.7

To put the machine in the transport position (Fig. 5.7) carry out the operations in the following order starting from the working position (Fig.5.9):

- 1) Make sure that the rake wheels are completely still.
- 2) Activate the tractor hydraulic control and raise the arms until they reach the stops (Fig. 5.7).
- 3) Fully retract the telescopic arms (A) (Fig. 5.2) by activating the tractor valve after selecting the "EXTENSION" position on the remote control in Fig. 5.3.
- 4) Adjust the angle of the arms (C) (Fig. 5.2) so they are parallel to the ground by activating the tractor valve after selecting the "ANGULATION" position on the remote control in Fig. 5.3.
- 5) Close the cylinder valves in Fig. 5.8 by turning the levers A for the right and left cylinders, levers B for the right and left cylinders, and lever C (optional)
- 6) Check that all safety signs and reflectors are installed, clean and visible.



**DANGER !!!**



**Danger of crushing.**

**Keep a safe distance away from the machine when the sections are being raised or lowered.**

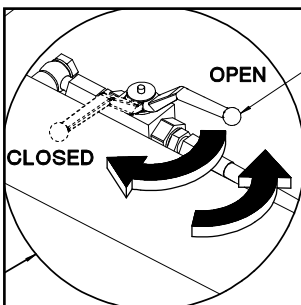
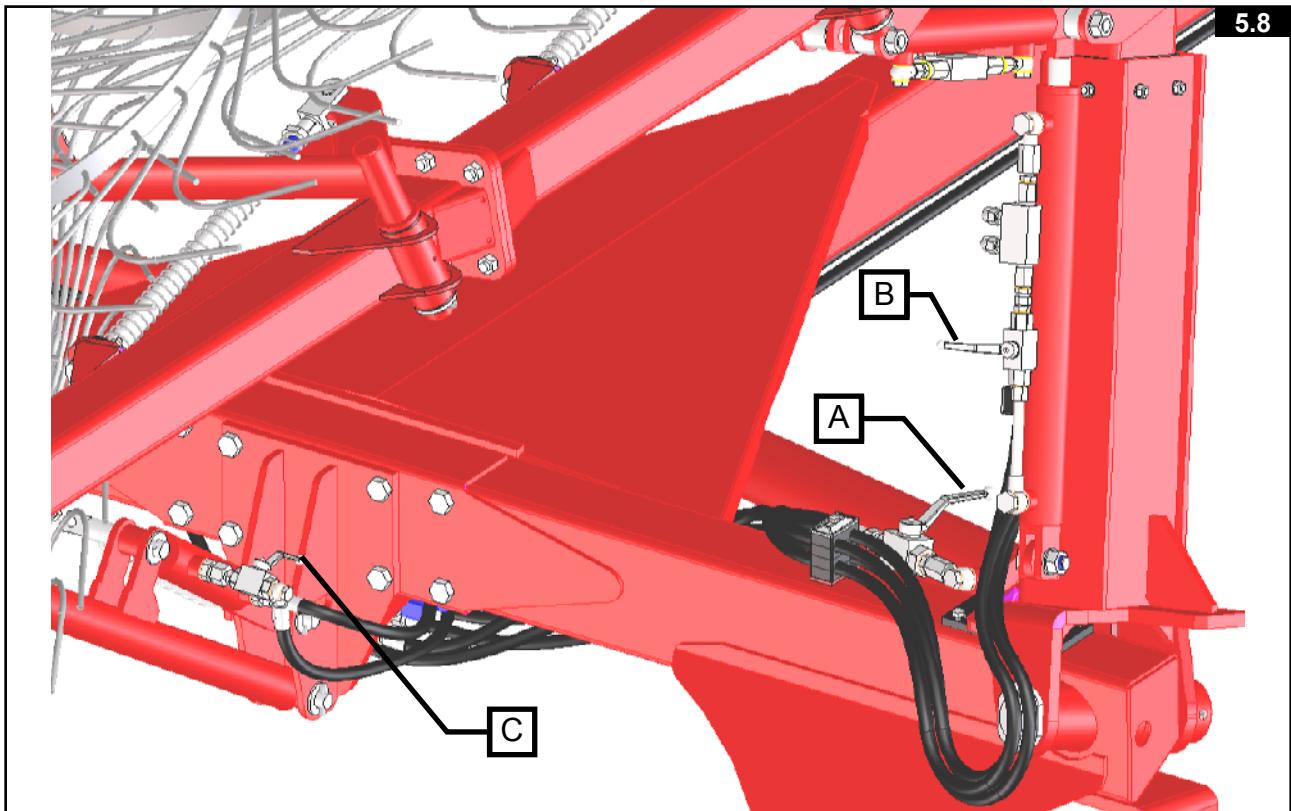

When the valve is in the "OPEN" position, the lever is parallel to the axis of the threaded fittings

When the valve is in the "CLOSED" position, the lever is perpendicular to the axis of the threaded fittings



**DANGER !!!**



Please check that there are no oil leaks that could endanger the stability of the machine.

## 5.5 COMPLIANCE WITH THE HIGHWAY CODE

Before taking the machine on public roads, make sure it is in compliance with the current regulations of the Highway Code. If the finished machine exceeds the legal size, follow local regulations for the special transport of oversized equipment.

Before going on public roads:

- 1) Check that the fold-up arms are locked in place.
- 2) Check that all valves are closed.
- 3) Replace immediately any broken reflector panels or damaged signal lights.

For road use of the machine is available on request a light kit for road use depending on the country of use.

## 5.6 WORKING POSITION

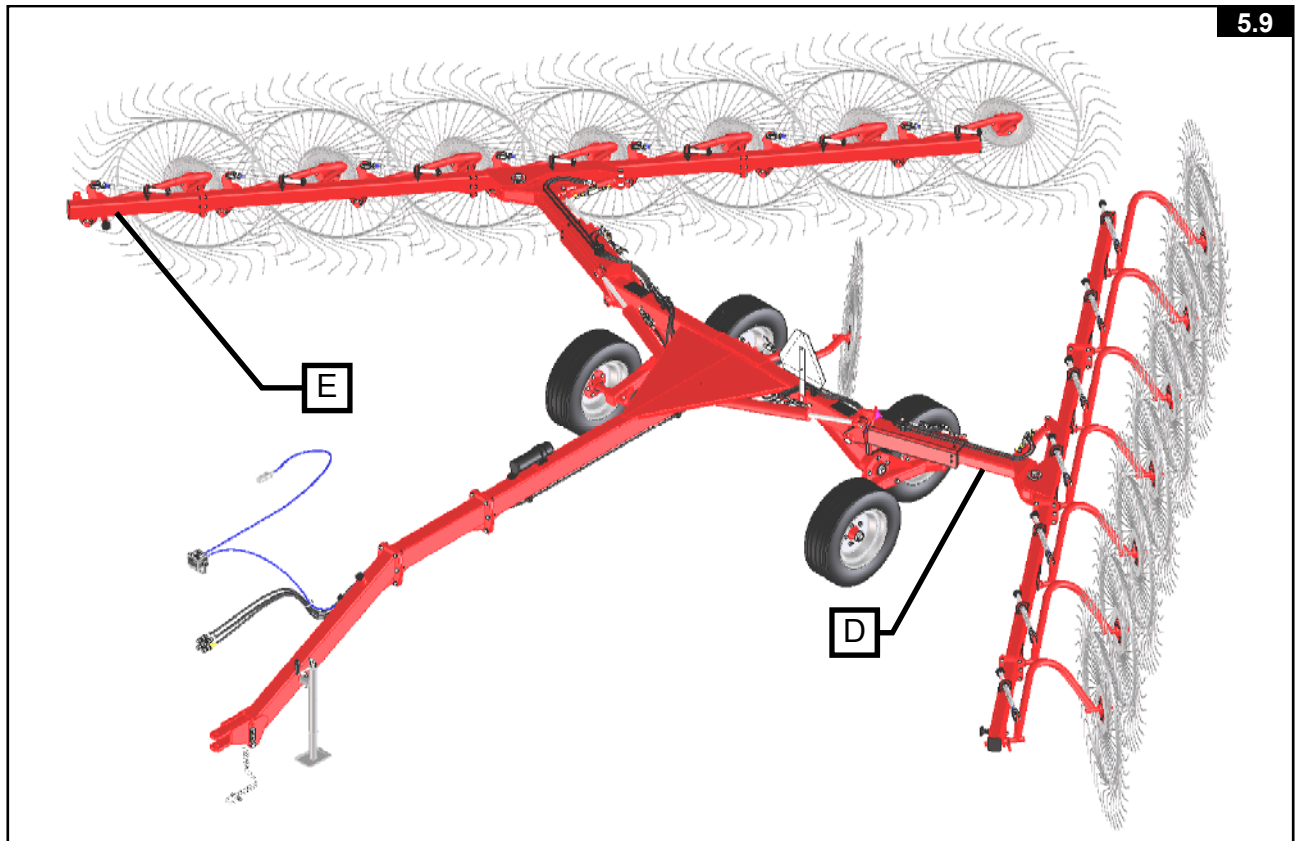



**DANGER !!!**



**Before putting the machine in the working position, check to make sure that there is no one within the operating range of the machine. If someone is there, make sure they move away out of range.**

To put the machine in the working position (Fig. 5.9) carry out the operations in the following order, starting from the transport position (Fig. 5.7):

- 1) Turn off the engine and remove the key.
- 2) Open the cylinder valves in Fig. 5.8 by turning the levers A for the right and left cylinders, levers B for the right and left cylinders, and lever C (optional).
- 3) Return to the tractor, operate the hydraulic controls to lower the rake arms not completely, but only until the rake tines just barely touch the ground.
- 4) Extend the telescopic arms (D) Fig. 5.9 by activating the tractor valve after selecting the "EXTENSION" position on the remote control in Fig. 5.3.
- 5) Adjust the angle of the arms (E) Fig. 5.9 by activating the tractor valve after selecting the "ANGULATION" position on the remote control in Fig. 5.3.
- 6) Finish lowering the rake arms.

The machine is in working position.

The tractor hydraulic system must be set in floating mode during operation.

## 5.7 ADJUSTING THE PRESSURE OF THE RAKE WHEELS ON THE GROUND

The pressure of the rake wheels on the ground can be adjusted with the spring (1) (Fig. 5.10):

- 1) Lower the rake arms by operating the tractor hydraulic lever.
- 2) Adjust the pressure of the rake wheel tines by turning the adjusting nut (B), with a 36mm - 1.41" wrench "A" (not included).
- 3) Compressing the spring (1) reduces the pressure on the ground.
- 4) Loosening the spring (1) increases the pressure on the ground.

The rake wheels are activated by their contact with the ground. The pressure of the rake wheels on the ground must be adjusted in order to have good raking action without damaging the crop.

The working speed affects the performance of the machine. Be sure to work at the recommended speed when checking the pressure of the rake wheels on the ground.

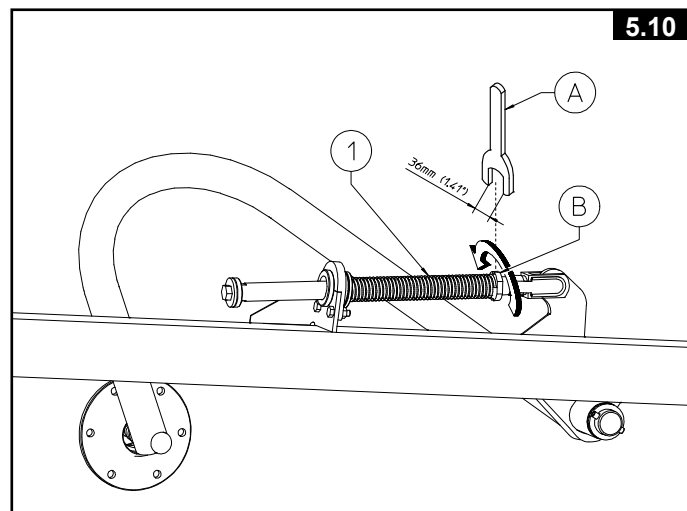

5.8 WORKING POSITION ADJUSTMENTS.

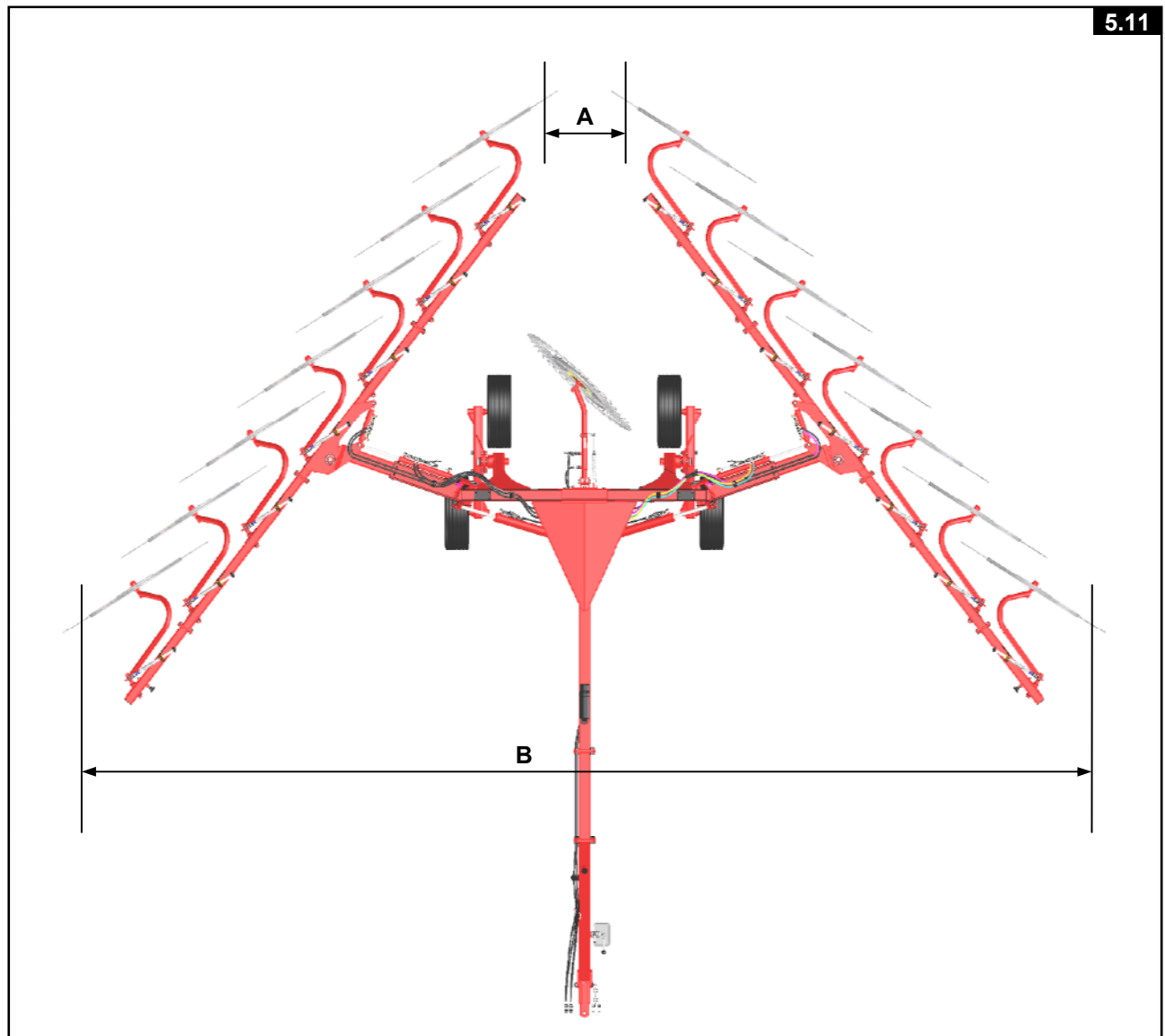

5.11

Maximum and minimum working and windrow widths (Fig. 5.11).

MODEL	QRX 12	QRX 14
Maximum Windrow Width	6' 7" (2m)	6' 7" (2m)
Minimum Windrow Width	3' (0.9m)	3' (0.9m)
Maximum Working Width	25' 1" (7.65m)	28' (8.5m)
Minimum Working Width	21'12" (6.7m)	24'11" (7.6m)

5.9 WORKING ON ONE SIDE ONLY



**DANGER !!!**



Before putting the machine in the working position, check to make sure that there is no one within the operating range of the machine. If someone is there, make sure they move away out of range.

Configuration for working only on the left side (Fig. 5.12).

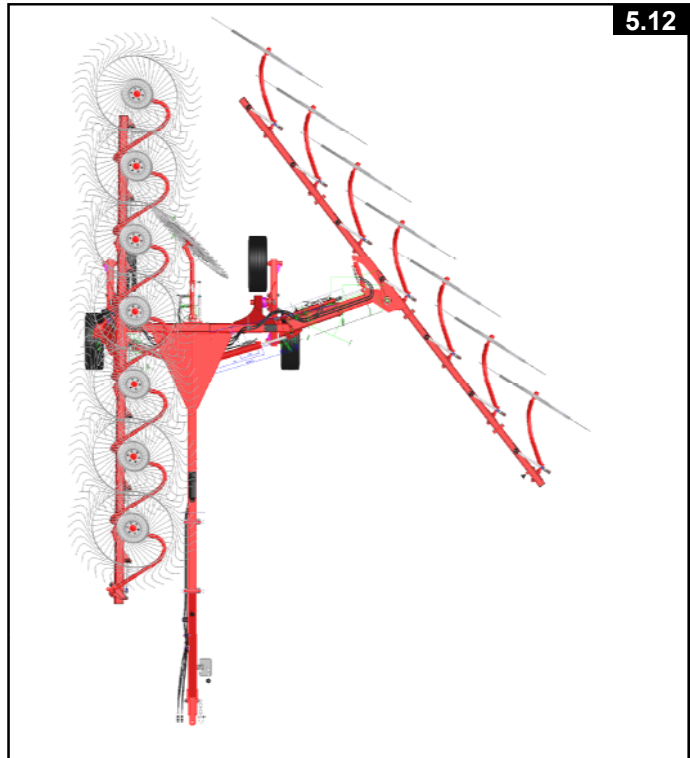

Configuration for working only on the right side (Fig. 5.13).

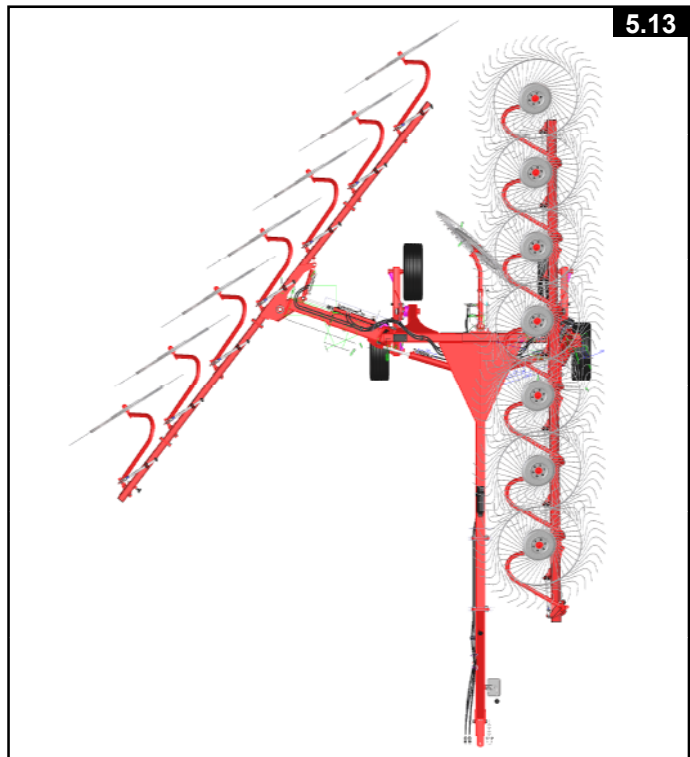



With the machine already in the transport position, to work on only one side carry out the following steps:

- 1) Turn off the tractor engine and remove the key.
- 2) Open the valves (A) and (B) of the side on which you wish to work.
- 3) Return to the tractor and lower the arm with the hydraulic cylinder. On the side in which the valves are closed, the arm (C) will stay raised with the minimum extension (Fig. 5.14).
- 4) Adjust the angle and extension of the rake arm used as desired.

The machine is ready to work on one side only.

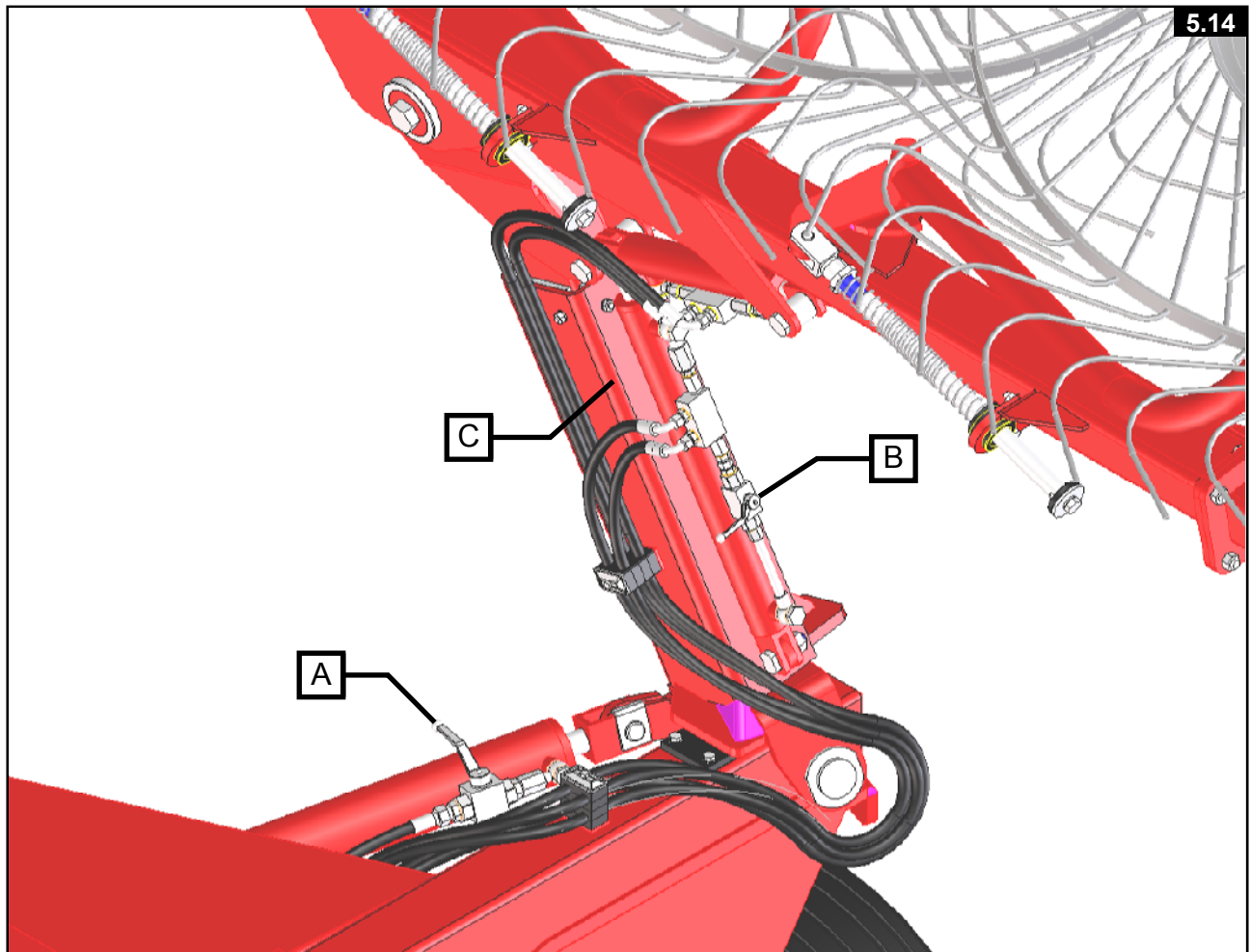

## 5.10 Locking the rake wheel arms in the raised position

To lock the rake wheel arm in the raised position (Fig. 5.15):

- 1) Unhook the spring assembly (B), removing the pin from the fork.
- 2) Connect the fork to the plate (C) with the pin of the fork.
- 3) Manually lift the arm (A), at the same time pull the spring knob (D) and leave it near the locking hole of the rake wheel arm (A).

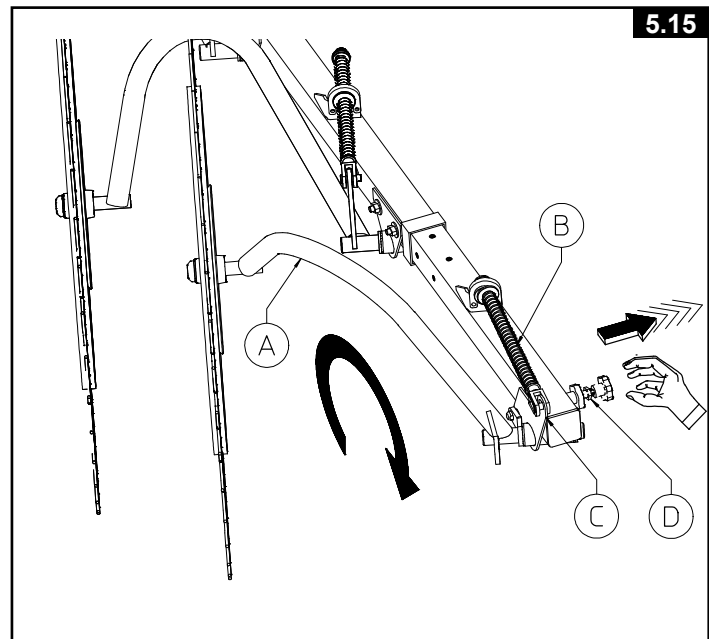

---

## SECTION 6 GENERAL INSTRUCTIONS FOR MAINTENANCE

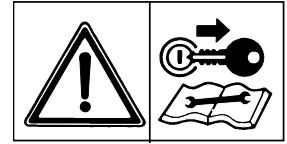
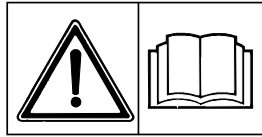
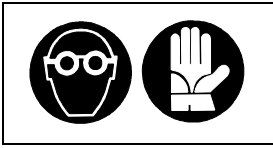

### 6.1 REPAIR WORK

Repair work must be done with the machine stationary and detached from the tractor.

Do not do any welding without the authorization of and/or instructions from the manufacturer.

With the machine on the ground, release the pressure of the hydraulic circuit and allow the machine to cool down.

The repair of components under pressure or that are live (springs, batteries, etc.) must be carried out only by expert persons with the proper equipment. Suitable protective clothing must be worn while working.

Always disconnect the machine from the tractor before doing any welding to avoid damaging the battery. Always wear a protective mask safety goggles and gloves when welding, sanding, grinding, or when using a hammer or drill.

Always work on the machine outdoors. If you must operate the machine when it is connected to the tractor in closed environments (for example, when testing after repairs or maintenance), make sure that the area is sufficiently ventilated to prevent the accumulating of noxious gases.

In order to acquire the necessary control and to work safely, practice performing various maneuvers, simulating those required in the field with the help of an expert.

### 6.2 STORAGE FOR LONG PERIODS

At the end of the season or when the machine will not be used for a fairly long period of time, it is recommended that the following be done:

- 1) Clean the machine, following the instructions, and let it dry;
- 2) Check it carefully and replace any damaged or worn parts;
- 3) Thoroughly tighten all bolts and nuts;
- 4) Lubricate/grease the machine, cover it completely and then store it in a dry place.

It is to the user's advantage to carry out these instructions carefully. In this manner, the machine will be in perfect condition when work is restarted.

When starting work again, repeat all checks, so as to be sure that you are working in conditions of maximum safety.

#### **IMPORTANT**

**During long periods of inactivity the cylinder shafts that remain exposed outside the cylinder barrel must be carefully protected with a layer of grease.**

---

### 6.3 MAINTENANCE INSTRUCTIONS

All cleaning, lubrication and maintenance operations must be carried out with the machine disconnected from the tractor.

In an emergency with the machine still connected to the tractor, turn off the engine, engage the parking brake and remove the key from the ignition.

Regular and proper maintenance is a basic requirement for long machine life and safe operation.

Pay special attention to all the stickers and tags attached to the machine.

All maintenance work should be done in an area with the proper tools and equipment readily at hand and in good condition. This area must be kept clean, dry and must have enough space to facilitate operations.

Each job must be done by trained personnel. Contact your nearest dealer.

Observe the warnings and follow the maintenance procedures given in this manual.

Do not use gasoline, solvents or other flammable liquids as detergents.

Use non-toxic and non-flammable commercial solvents, authorized by the competent authorities.

Do not use compressed air or high pressure water to clean the machine. If this is unavoidable, then wear glasses with lateral protection and limit the pressure as much as possible. When work is finished, inspect and check the machine completely with the machine disconnected from the tractor.

After the first 10 (ten) hours of use:

Check the tightness of all nuts and bolts, especially those on the wheels.

### 6.4 TIRES

Check the tire pressure regularly. Follow the manufacturer's recommendations regarding tire pressure. The removal, remounting and repair of tires must be carried out only by trained personnel.

### 6.5 HYDRAULIC CIRCUIT



**DANGER !!!**



**The hydraulic circuit is under pressure. Maximum working pressure: 3000 psi (200 bar).**

Before connecting the hoses to the tractor hydraulic system, make sure that the machine and tractor hydraulic circuits are not under pressure. Depressurize the hydraulic circuit before disconnecting the hoses.

To avoid making wrong connections, mark the hoses with different colors.



**DANGER !!!**



**The functions may be reversed (e.g. raising/lowering) and could cause accidents.**

---

Check the hydraulic hoses regularly. In the case of normal use and wear, replace them every 5 (five) years. Damaged or worn hoses must be replaced immediately. When replacing, be sure to use hoses with the specifications recommended by the machine manufacturer.

Use appropriate means to locate leaks. Protect the body and hands from the oil under pressure. Use paper and cartons to contain any spillage. Never use your hand. If the oil penetrates the skin, it may cause serious injury. Consult a physician immediately.



**DANGER !!!**



**Before doing any adjustments, maintenance or repair work, lower the machine to the ground, depressurize the hydraulic system, turn off the engine, remove the ignition key and wait until all moving parts have come to a complete stop.**

## 6.6 SCRAPPING THE MACHINE

The machine consists mainly of ferrous material, which must be disposed of according to the regulations in force in the country concerned.

There is also a small amount of plastic that must be disposed of according to the regulations in force in the country concerned.

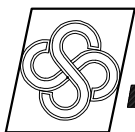

**sitrex** AGRICULTURAL MACHINERY SpA .<sup>®</sup>

Zona Industriale-Viale Grecia, 8  
06018 TRESTINA-(Perugia)-ITALY  
Tel. +39.075.8540021-Telefax +39.075.8540523  
e-mail: [sitrex@sitrex.it](mailto:sitrex@sitrex.it) [www.sitrex.com](http://www.sitrex.com)

