

AGRICULTURAL MACHINERY

sitrex®
Spa

ASSEMBLY
USE AND MAINTENANCE
SPARE PARTS LIST

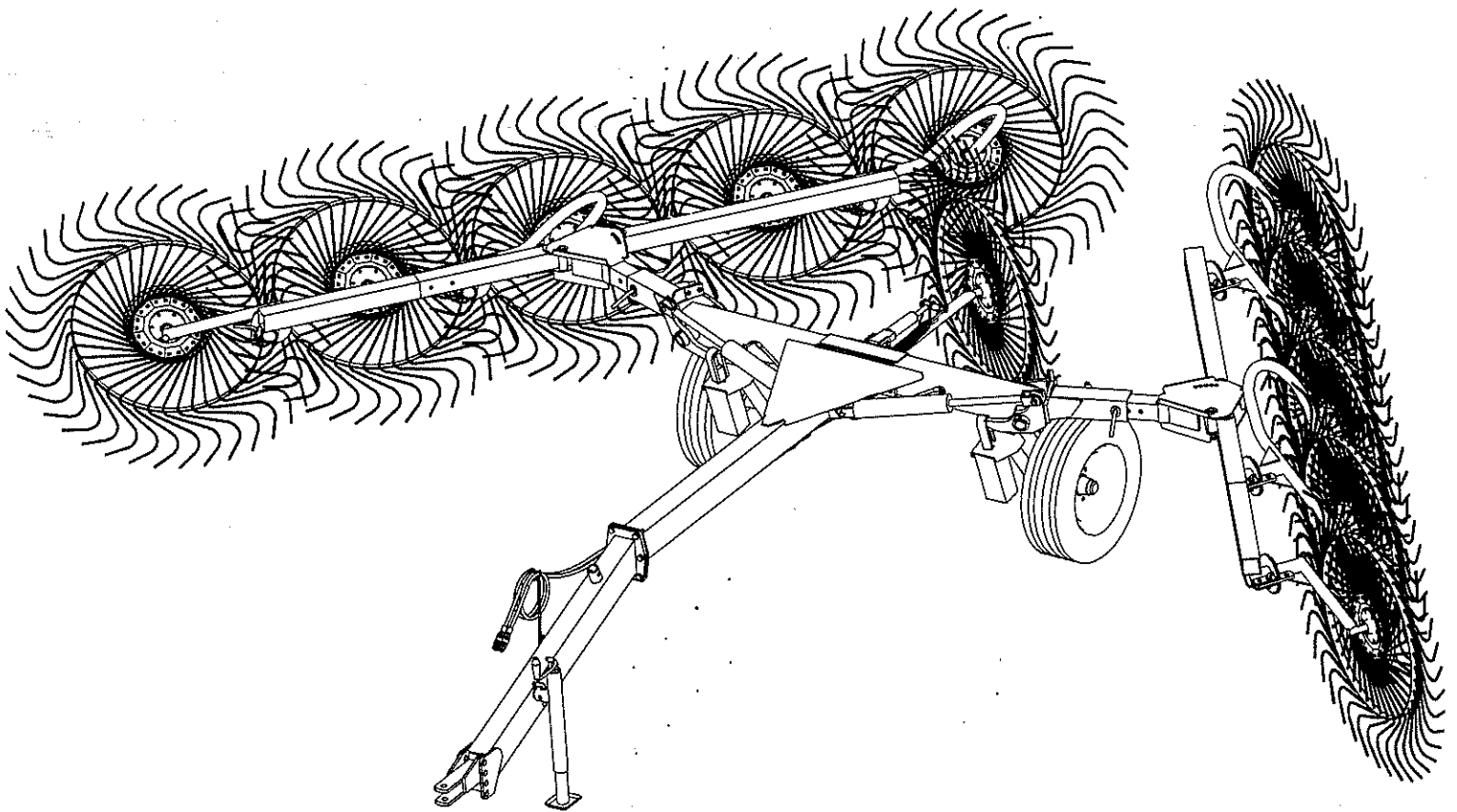

QR / 8-10-12

01/2009

Warranty

The manufacturer warrants new machinery to be free from defects in material and workmanship at the time of delivery to the original purchaser if correctly set up and operated according to this Operator's Manual.

The manufacturer undertakes to repair or replace free of charge any defective part which should be returned by the purchaser (freight prepaid) and found to be defective on inspection authorised by the manufacturer during the warranty period.

This warranty shall be valid for 12 (twelve) months from the delivery of the goods to the original purchaser.

If the customer is unable to return the defective part to the manufacturer, the manufacturer cannot be held responsible for any cost due for repair or replacement of any part of the machine. He shall only supply the part(s) required for such repair and/or replacement.

The warranty shall be considered null and void when it is evident that the machine has been improperly used or at least repaired without authorisation.

The manufacturer shall not be held responsible for any obligation or agreement reached by any employers, agents or dealers who do not comply with the above warranty. The manufacturer cannot be held responsible for the subsequent damages. This warranty replaces any other warranty, either explicit or implied, as well as any other obligation of the manufacturer.

NOTE:

All warranty work or repairs must be approved by the manufacturer before work begin.

Any work or repairs made before approval may not be covered under warranty.

TABLE OF CONTENT

CHAPTER

- 1) GENERAL INSTRUCTIONS
- 2) GUIDE TO THE SIGNS AND SYMBOLS
- 3) TECHNICAL NOTES
- 4) ASSEMBLY INSTRUCTIONS
- 5) PRODUCT IDENTIFICATION
- 6) ADJUSTMENTS FOR MACHINE USE
- 7) TRANSPORT BY ROAD
- 8) INSTRUCTIONS FOR WORK
- 9) GENERAL MAINTENANCE INSTRUCTIONS
- 10) OPTIONAL CENTER RAKE WHEEL KIT
- 11) SPARE PARTS LIST

General instructions for the operation and maintenance

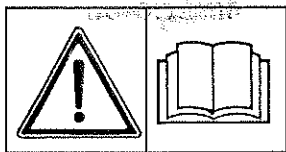

Read and understand the Operator's Manual and all safety labels before operating this machine.

Before starting off for work, be sure that the machine is correctly assembled and in good operating condition.

When moving the machine from the transport position to the working position and vice versa, make sure that nobody is within the machine pivoting area.

The transport arms must always be attached during transport.

While the transport arms are attached, do not operate for any reason whatsoever the hydraulic cylinders for opening the machine or lifting the rake wheels.

When in operation, do not turn around at full speed.

On particularly uneven ground, do not operate with the machine in the fully-opened position. In addition, operate at a reduced speed.

If it is noticed that the machine is not operating properly (rake wheels putting too much pressure on the ground, etc.) the problem must be corrected immediately to avoid causing damage to the machine.

If machine maintenance work, repairs or adjustments must be done in the field, they should be done at a spot where the ground is firm and level. Turn off the tractor and apply the parking brake. Use the proper tools and wear suitable protection (safety goggles, work gloves, etc.).

If any maintenance work, repairs or adjustments are done which require that some parts be removed and/or that screws, nuts, pins, etc. be loosened or removed, always make sure that everything is reassembled or retightened as it had been prior to making repairs or adjustments.

Follow the schedule provided for maintenance.

By following these suggestions it will be possible to keep the machine operating safely and efficiently, to the benefit of the user.

Attach only to a tractor with sufficient drawbar and braking capacity.

Precision steering, tractor adherence, road holding and efficient braking are influenced by the type of implement, weight, ballast of front axle, ground or road conditions. It is therefore of the utmost importance to be cautious in every given situation.

Drive speed must be adapted to ground conditions as well as to roads and paths. Always avoid abrupt changes of direction.

Be particularly cautious when turning corners, paying attention to machine overhang, length, height and weight.

Using the machine for the purpose for which it was manufactured. The QuickRake must only be used for the work for which it has been designed: raking on the ground and forming windrows of pre-mowed hay crops and straw.

Never use a narrow track tractor on very uneven or steeply sloping ground.

Never leave the tractor seat while the machine is operating.

Carrying people or animals on the machine when working or in transport is strictly forbidden.

Projection of stones and foreign objects

For driver safety, always use a tractor equipped with a cab. Even when the machine is used in accordance with its purpose, objects may be projected. Stones and other foreign objects projected by the moving parts can travel a considerable distance. Keep all persons and animals away from the danger zone.

Danger: the hydraulic cylinders are empty to start with, and the first time they are filled very dangerous uncontrolled movements can take place. It is recommended that the cylinders be filled with oil before connecting them to the machine, and the arms should be raised and lowered with the controls a few times in order to eliminate air from the circuit. These operations must be done in complete safety conditions, with the machine attached to the tractor and the operator sitting in the tractor driver's seat working the hydraulic controls, making sure that nothing and nobody is within the range of movement of the machine rake arms.

Guide to the signs and symbols

These signs and symbols give information to the operator on how to make the best use of the machine so as to prolong life, avoid damage, optimise work and, above all, to avoid injury to the operator and anyone within range of the machine.

Warning signs

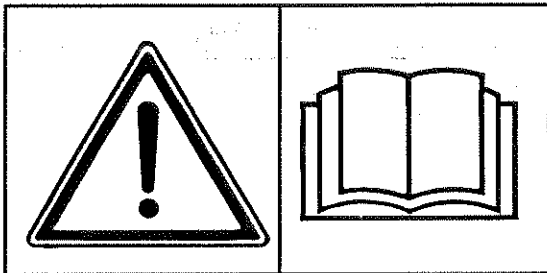

A) Before beginning operations, read the instruction manual carefully.

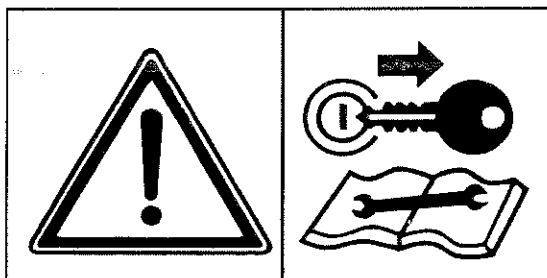

B) Before doing any maintenance or repair work, stop the machine at a suitable spot. Turn off the tractor motor, apply the brake, remove the key from the ignition and consult this manual.

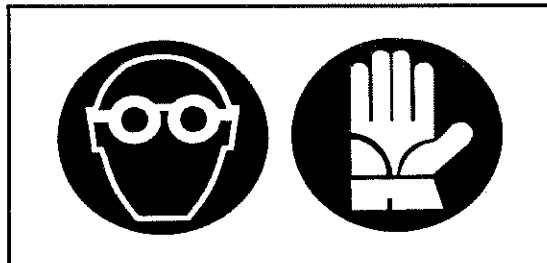

C) This is a warning to use proper accident protection when carrying out maintenance and repairs

Danger signs

DANGER



Indicates an impending dangerous situation which, if not avoided, will cause death or severe personal injury.

ATTENTION



Indicates a potentially dangerous situation which, if not avoided, could cause death or severe personal injury, including dangers which are present when protection is removed.

CAUTION



indicates a potentially dangerous situation which, if not avoided, can provoke less severe or minor injuries.

Technical notes

We will provide a few examples to make it easier to choose which of the various accessories to use for each step of assembly. An approximate equivalent of the metric measurements is given in inches.

1) PINS AND SCREWS

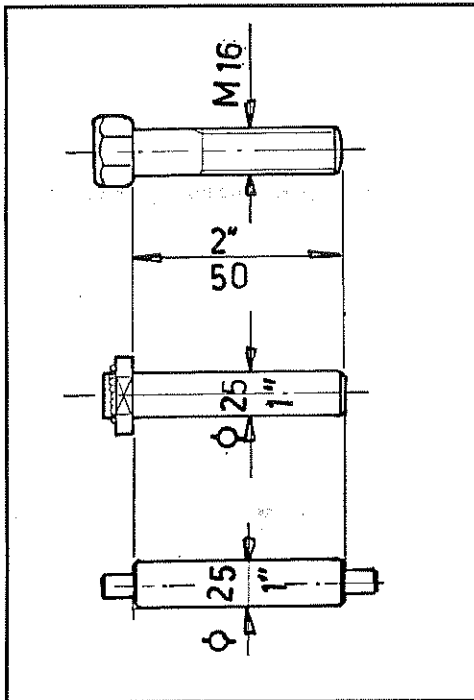

Example: a pin with a 25 mm (1") diameter and a screw with an M 16 (5/8") diameter, both 50 mm (2") long, will be listed as:

D 25 x 50 (D 1" x 2") and M 16 x 50 (D 5/8" x 2").

2) SHIMS, SPACERS, BUSHINGS AND WASHERS

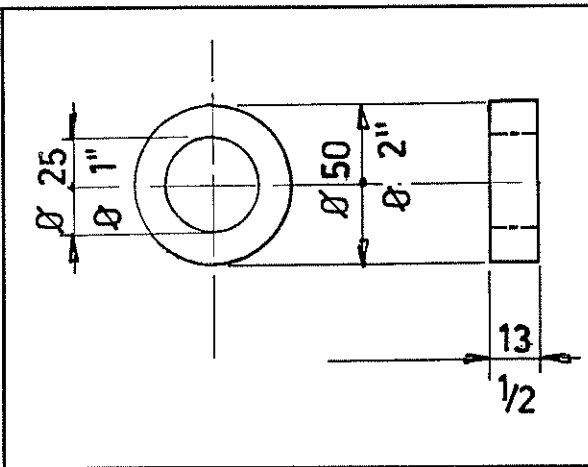

Example: a shim, spacer, bushing or washer with an inside diameter of 25 mm (1"), outside diameter of 50 mm (2") and thickness or length of 13 mm (1/2") will be listed as:

D 25 - 50 x 13 (D 1" - 2" x 1/2").

3) NUTS, GREASE NIPPLES

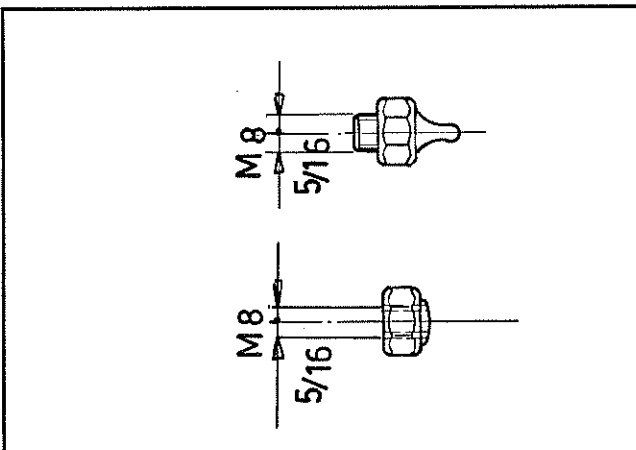

Example: a nut or grease nipple having a thread of M 8 (5/16") will be listed as:

M 8 (5/16")

4) PINS AND SPLIT PINS

Example: a pin or split pin having a diameter of 8 mm (5/16") and a length of 50 mm (2") will be listed as:
D 8 x 50 (D 5/16" x 2")

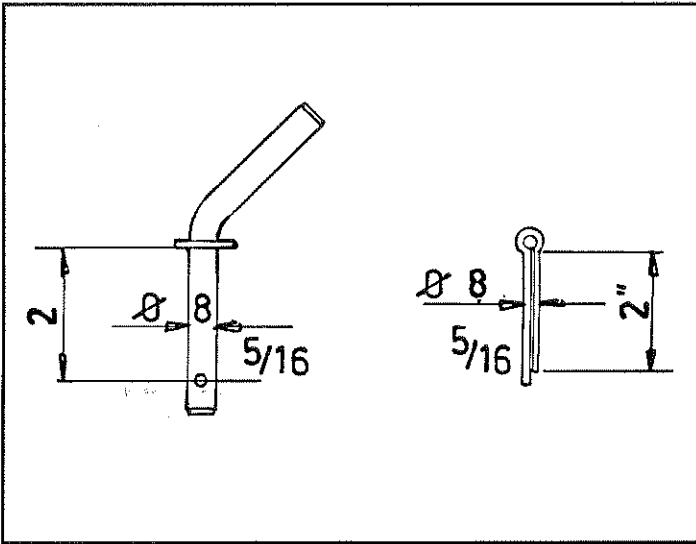

5) CLIPS

Example: a clip with a diameter of 3 mm (1/8") will be listed as:
D 3 mm (1/8")

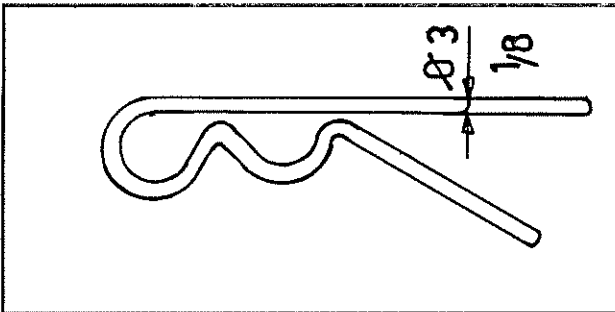

6) SPRINGS

Example: a spring with a wire diameter of 3 mm (1/8"), outside diameter of 25 mm (1") and length of 76 mm (3") will be listed as:
D 3 - 50 x 76 (D 1/8" - 2" x 3")

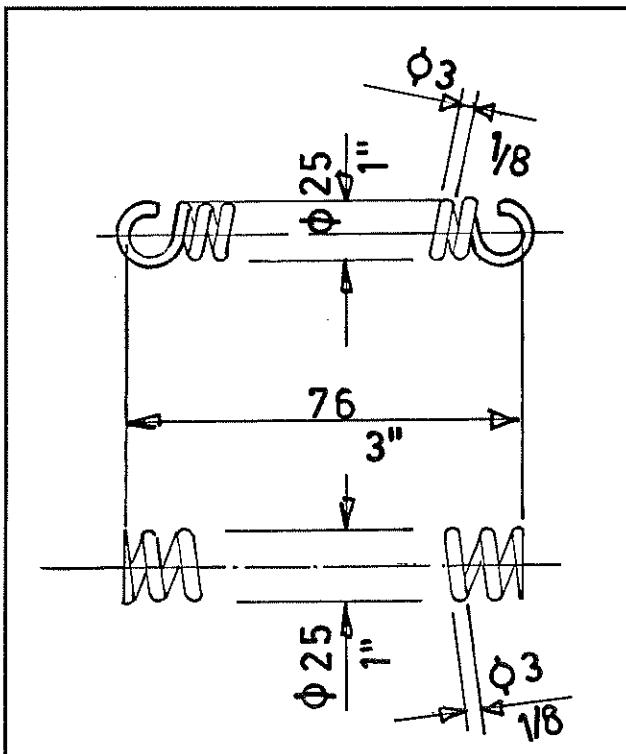

Assembly instructions

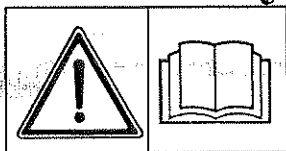

ATTENTION

Assembly must be done carefully and accurately, for the safety of the person(s) doing the assembling and to ensure proper machine operation.

Assembly should be done on a flat, solid surface, using the proper tools and wearing suitable clothing, making sure that all people not involved in the assembly be kept at a safe distance. Assemblers must provide suitable lifting mechanisms and supports for stabilizing the partially assembled units, so as to prevent them from falling and causing damage or injury. The steps for assembly are illustrated in following. Depending on the experience of the assemblers and the tools available, it is not necessary that the instructions be followed in the exact order given here, but the safety precautions described above must always be followed carefully and scrupulously.

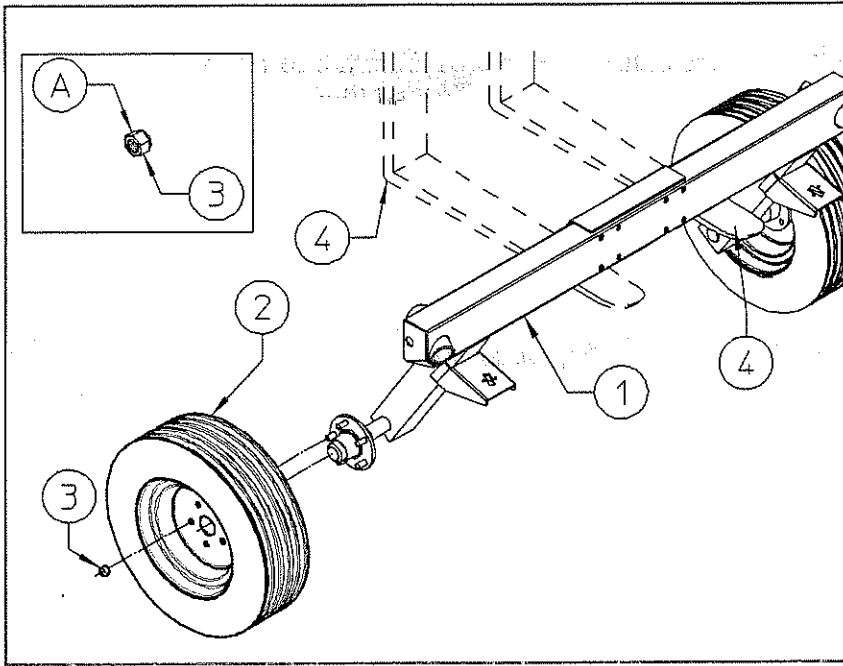

Mount wheels (2) to hubs on frame (1) using special nuts (3).

The spherical side "A" off the nut (3) must be always turned towards the wheel rim flange. The forks (4) of a forklift may also be used to support the assembly.

Item 3: 10 special nuts M16 (5/8")

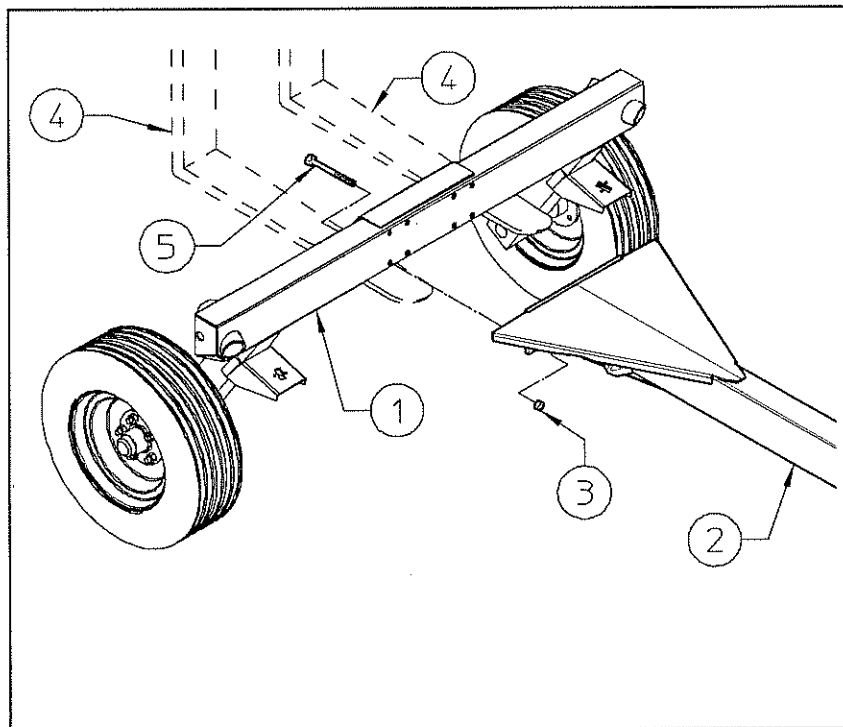

Attach the drawbar (2) to the frame (1) and fastening it with screws (5) and nuts (3).

Item 5: 8 screws M16 x 140 (5/8" x 5 1/2")

Item 3: 10 nuts M16 (5/8")

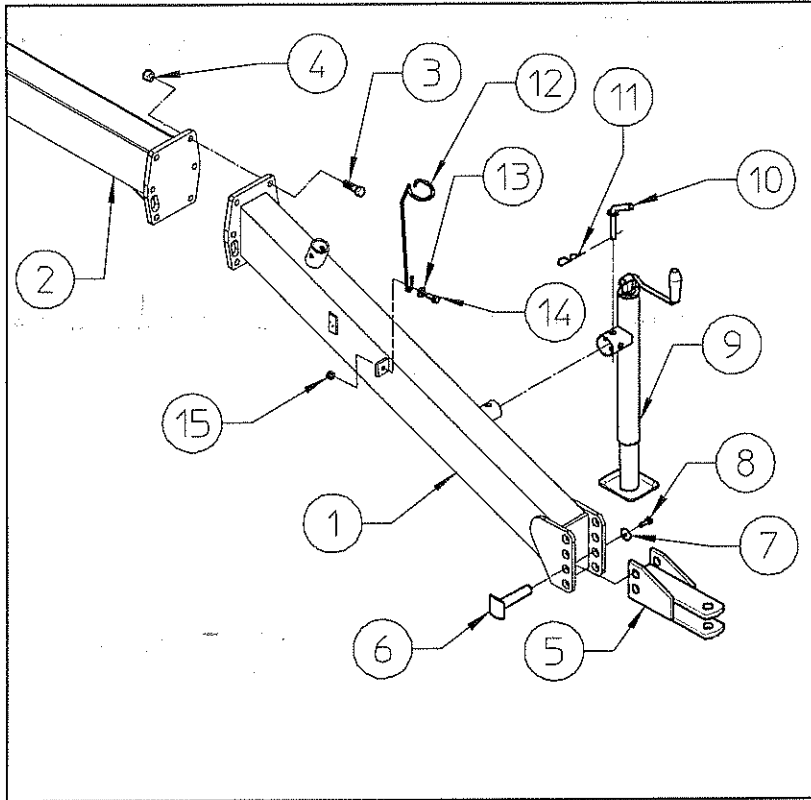

Attach the drawbar (1) to the drawbar (2) and fastening it with screws (3) and nuts (4). Attach the tractor hitch (5) to the drawbar (1) using the two pins (6), fastening with the screws (8) and washers (7). To choose which should be used see ADJUSTMENTS FOR MACHINE USE section.

Attach parking stand (9) to drawbar (1), fastening it with pin (10) and clip (11).

Assemble the support hose (12) with the screw (14), washer (13) and nut (15).

Item 3: 6 screws M16 x 50 (5/8" x 2")

Item 4: 6 nuts M16 (5/8")

Item 6: 2 pins $\varnothing 25 \times 124$ (1" x 5")

Item 7: 2 washers $\varnothing 12-36 \times 2.5$ ($\varnothing 15/32''-1 27/64'' \times 3/32''$)

Item 8: 2 screws M12 x 20 (15/32" x 13/16")

Item 10: 1 pin $\varnothing 15 \times 78$ ($\varnothing 19/32'' \times 3 1/8''$)

Item 11: 1 clip $\varnothing 3$ ($\varnothing 1/8''$)

Item 13: 1 washer $\varnothing 12$ ($\varnothing 1/2''$)

Item 14: 1 screw M12 x 35 (15/32" x 1 5/8")

Item 15: 1 nut M12 (15/32")

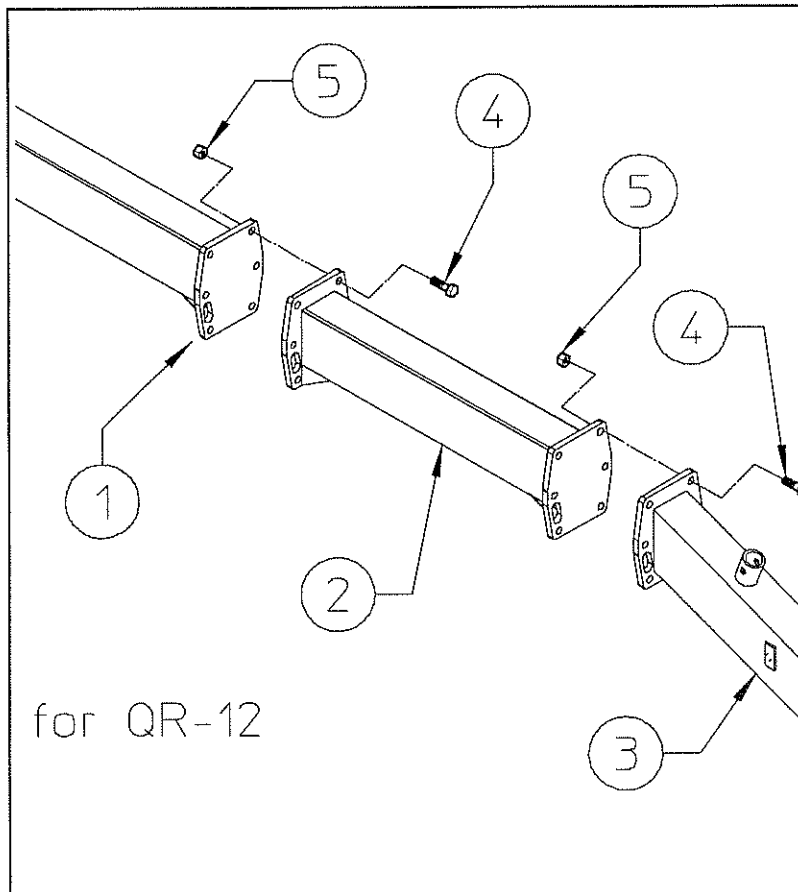

For QR-12 only.

Insert and attach the drawbar extension (2) and fastening it with screws (4) and nuts (5).

Item 4: 6+6 screws M16 x 50 (5/8" x 2")

Item 5: 6+6 nuts M16 (5/8")

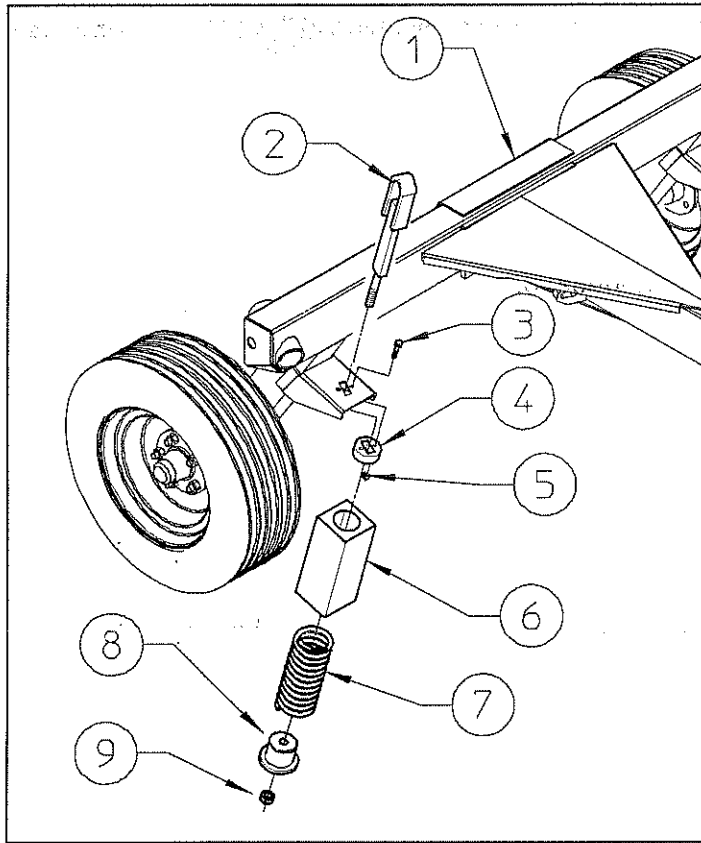

Assemble the sliding (4) with the screw (3) and nuts (5).

Insert tie rod (2) to hole drawbar (1), fastening it with pin (10) and clip (11).

Insert the tie rod (2) into the rectangular hole. From underneath, place over the tie rod the casing (6), the spring (7), the bush (8) and the nut 9. The nut must be screwed on to the tie rod so that a threaded section 6 mm (1/4") long protrudes from the nut. Then adjust the spring to get the right rake wheel ground pressure depending on your work requirements (see instructions on use in the field).

Repeat the operation on the left side of the machine.

Item 3: 4 screws M8 x 35 (5/16" x 1 6/16")

Item 5: 4 nuts M8 (5/16")

Item 9: 2 nuts M20 (13/16")

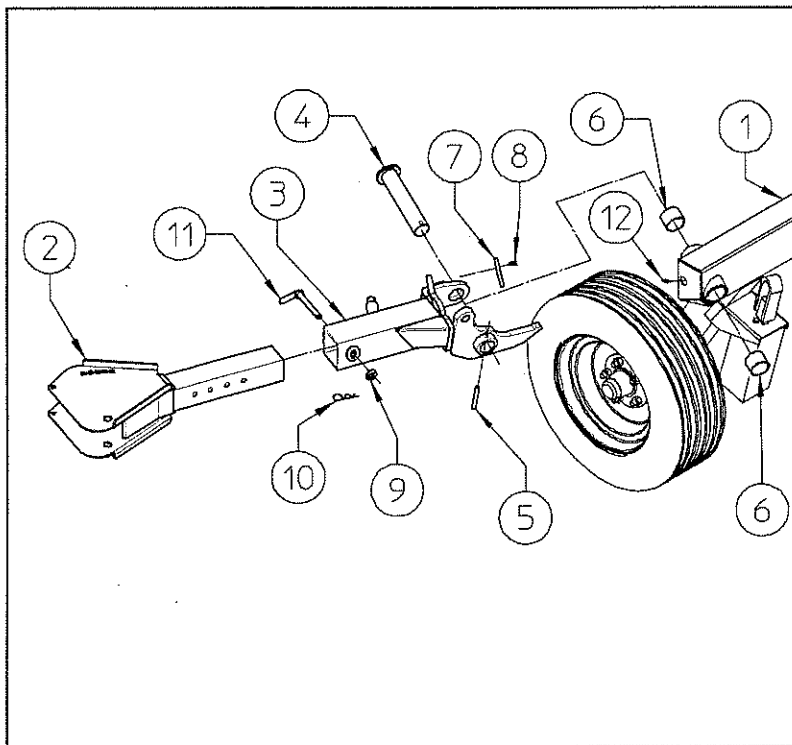

Fit bushings (6) on proper seats of frame (1). Fit in proper seats grease nipple (12).

Attach the arm (3) (R.H.-L.H.) to the frame (1) using pins (4). Fasten pins (4) with pins (5).

Assemble the block (7) with the screw (8).

Insert the removable arms (2) and fasten them into position with the pins (11), washer (9) and clip (10).

Item 4: 2 pin $\varnothing 50 \times 243$ ($\varnothing 2'' \times 9 1/2''$)

Item 5: 2 spring pins $\varnothing 12 \times 70$ ($\varnothing 1/2'' \times 2 3/4''$)

Item 6: 4 bushings $\varnothing 50-60 \times 50$ ($2''-2 3/8'' \times 2''$)

Item 8: 4 screws M8 x 20 ((5/16" x 3/4")

Item 9: 2 washers $\varnothing 16$ (5/8")

Item 11: 2 pins $\varnothing 15 \times 126$ ($\varnothing 19/32'' \times 5''$)

Item 10: 2 clips $\varnothing 4$ ($\varnothing 5/32''$)

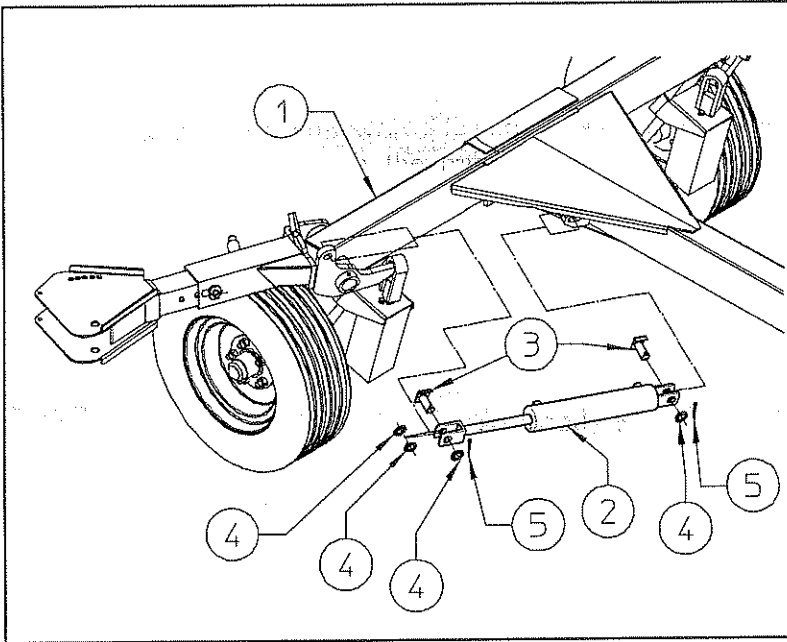

Attach the cylinders (2) to the lugs using pins (3) and split pins (5). Assemble the cylinders with distance washers (4) as shown in the diagram.

Item 3: 4 pin $\varnothing 25 \times 58$ ($\varnothing 1'' \times 2 \frac{5}{16}''$)

Item 4: 8 washers $\varnothing 25$ ($\varnothing 1''$)

Item 5: 4 split pins $\varnothing 6 \times 35$ ($\varnothing 1/4'' \times 1 \frac{1}{2}''$)

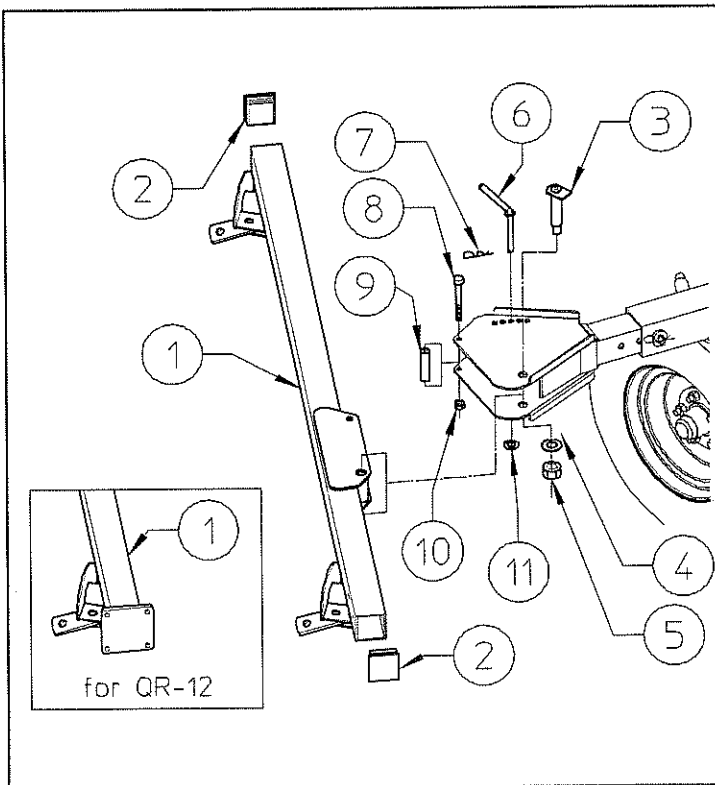

QR - 8

Attach the main pipe r.h. (1) to arm using pin (3), washer (4) and nut (5), fastening main pipe with pin (6), washer (11) and clip (7).

Mount bush (9) using screw (8) and nut (10).

Insert plug (2) to main pipe (1).

Item 3: 2 pin $\varnothing 25 \times 135$ ($\varnothing 1'' \times 5 \frac{1}{8}''$)

Item 4: 2 washers $\varnothing 21$ ($\varnothing 26/32''$)

Item 5: 2 nuts M20 ($25/32''$)

Item 6: 2 pins $\varnothing 15 \times 114$ ($\varnothing 19/32'' \times 4 \frac{1}{2}''$)

Item 7: 2 clips $\varnothing 4$ ($\varnothing 5/32''$)

Item 8: 2 screws M12 x 120 ($15/32'' \times 4 \frac{3}{4}''$)

Item 9: 2 bushings $\varnothing 13-25 \times 93$ ($1/2''-1'' \times 3 \frac{5}{8}''$)

Item 10: 2 nut M12 ($15/32''$)

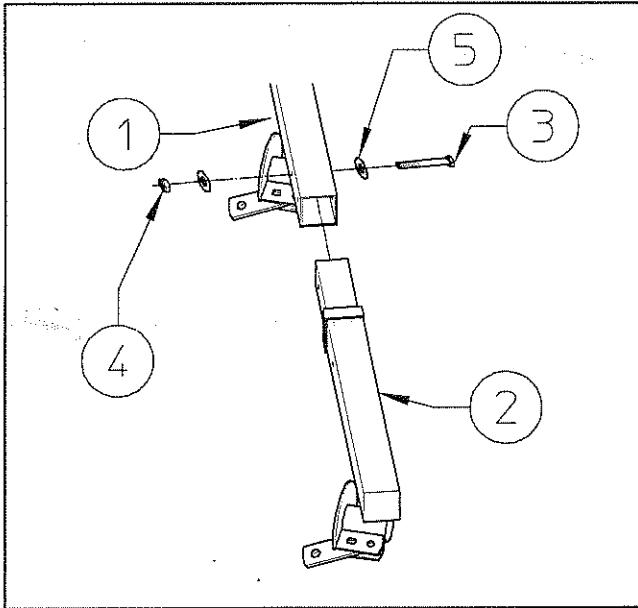

QR - 10
 Insert pipe (2) to the main pipe (1),
 fastening it with the screws (3), washers (5)
 and nuts (4).

- Item 3: 2+2 screws M12 x 100 (15/32" x 4")
- Item 4: 2+2 nut M12 (15/32")
- Item 5: 4+4 washer \varnothing 12 (\varnothing 1/2")

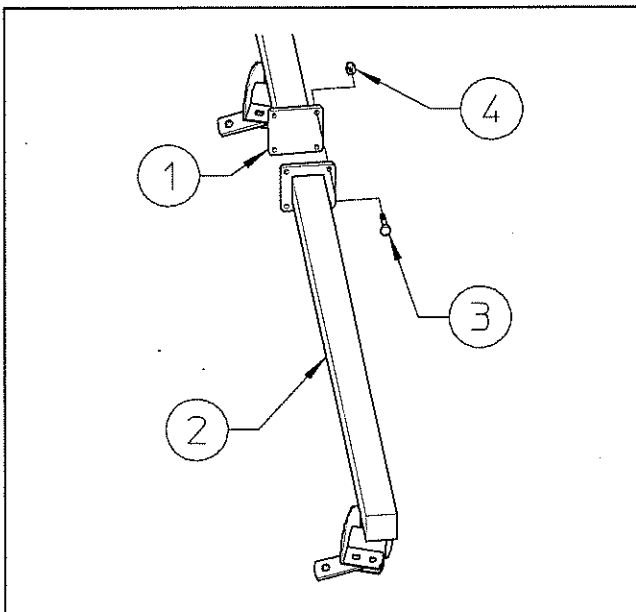

QR - 12

Fit the extension pipe (2) to the main pipe
 (1), fastening it with the screws (3) and nuts
 (4).

- Item 3: 4+4 screws M12 x 35 (15/32" x 1 5/8")
- Item 4: 4+4 nut M12 (15/32")

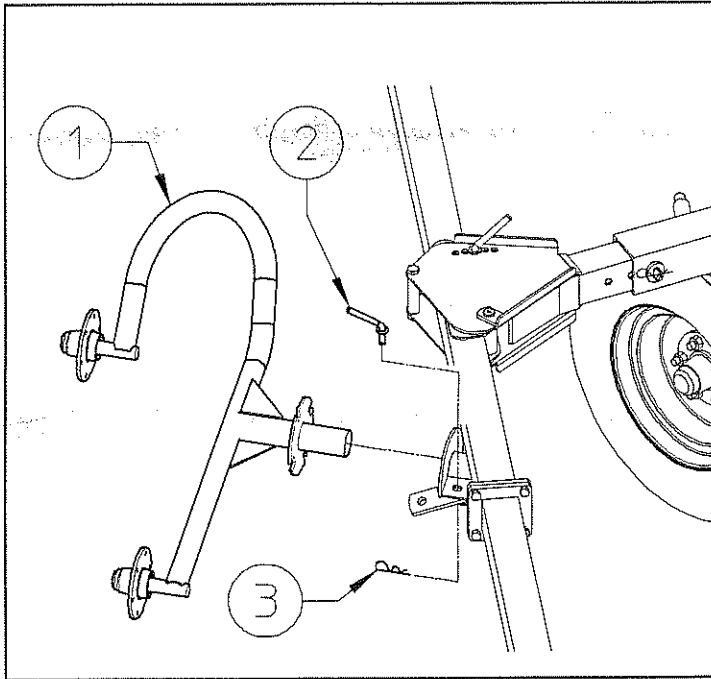

Attach brackets (1) to pipe, fastening with levers, pins (2) and clip (3).

Item 2: pins $\varnothing 12 \times 38$ ($\varnothing 1'' \times 1 \frac{1}{2}''$)

Item 7: clips $\varnothing 3$ ($\varnothing 1/8''$)

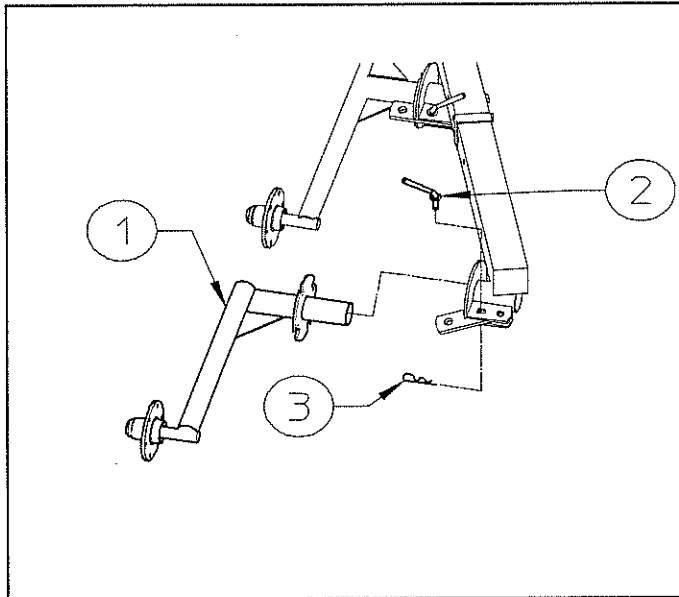

Attach brackets (1) to pipe, fastening with levers, pins (2) and clip (3).

Item 2: pins $\varnothing 12 \times 38$ ($\varnothing 1'' \times 1 \frac{1}{2}''$)

Item 7: clips $\varnothing 3$ ($\varnothing 1/8''$)

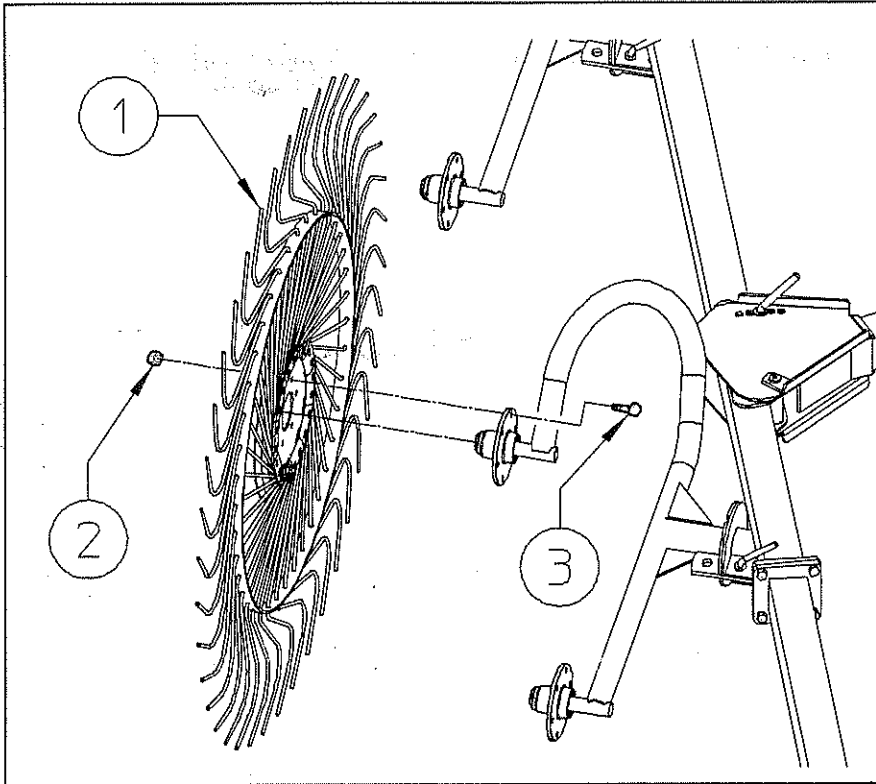

Attach the rake wheels (1) to the hubs using screws (3), washers (4) and nuts (2).

- Item 2: nuts M10 (25/64")
- Item 3: screws M10 x 25 (25/64" x 1")
- Item 4: growers $\varnothing 10.5$ (27/64")

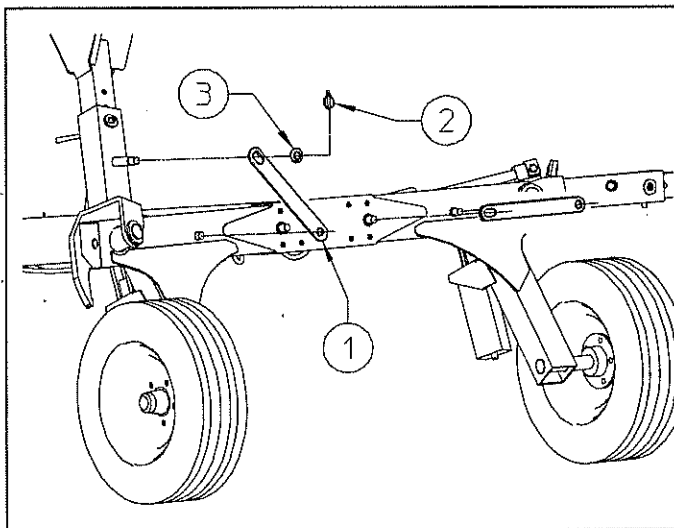

Position the transport arm 1 (R.H. – L.H.) on horizontal position, lock with pin (2) and washer (3).

HYDRAULIC SYSTEM ASSEMBLY

Assemble the cylinders and the oleo-dynamic system as shown. When using for the first time, make sure there are no oil leaks. If there should be any, tighten the pipe fittings

Attach the reducer nipples (12) at fitting (9).

Connect the fitting hole (9) with washer (10) and fitting screw on cylinders (20)

Connect pipe (5) and (6) at fitting (12) and union T (13)

Connect eye-ring end of pipes (7) – (8) to the other side cylinders (20) and the rotating female ends on the other union T (13)

Connect the rotating female ends of pipes (3) – (4) to union T (13)

Place washers (2) and connect the quick-release coupling (1) to the straight male ends of pipes (3) – (4)

Check to make sure that all connections are correctly fastened.

Attach the hose collar (15) and (18) to the lugs on drawbar, fastening on correctly position (see shown)

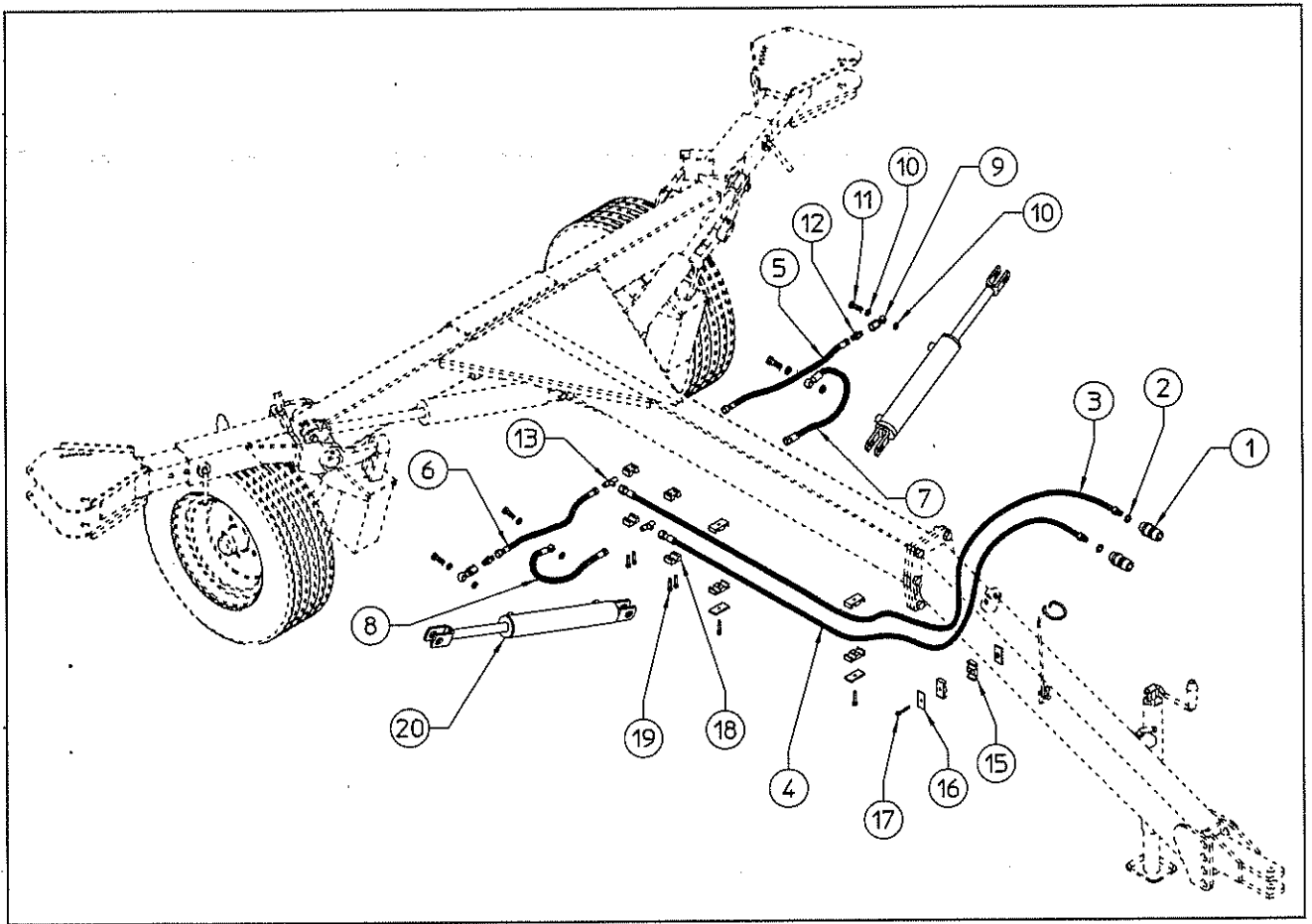

Danger: the hydraulic cylinders are empty to start with, and the first time they are filled very dangerous uncontrolled movements can take place. It is recommended that the cylinders be filled with oil before connecting them to the machine, and the arms should be raised and lowered with the controls a few times in order to eliminate air from the circuit. These operations must be done in complete safety conditions, with the machine attached to the tractor and the operator sitting in the tractor driver's seat working the hydraulic controls, making sure that nothing and nobody is within the range of movement of the machine rake arms.

Product identification

Please write below the type and serial number of the machine. This information is to be provided to the dealer for all spare parts orders.

Optional equipment
Center wheel kit
Safety chain

 AGRICULTURAL MACHINERY sitrex [®] <small>06018 TRESTINA-PERUGIA-ITALY</small> TEL.075-8540021 FAX 075-8540523	
SERIE	N°
MADE IN ITALY	

Machine Specifications

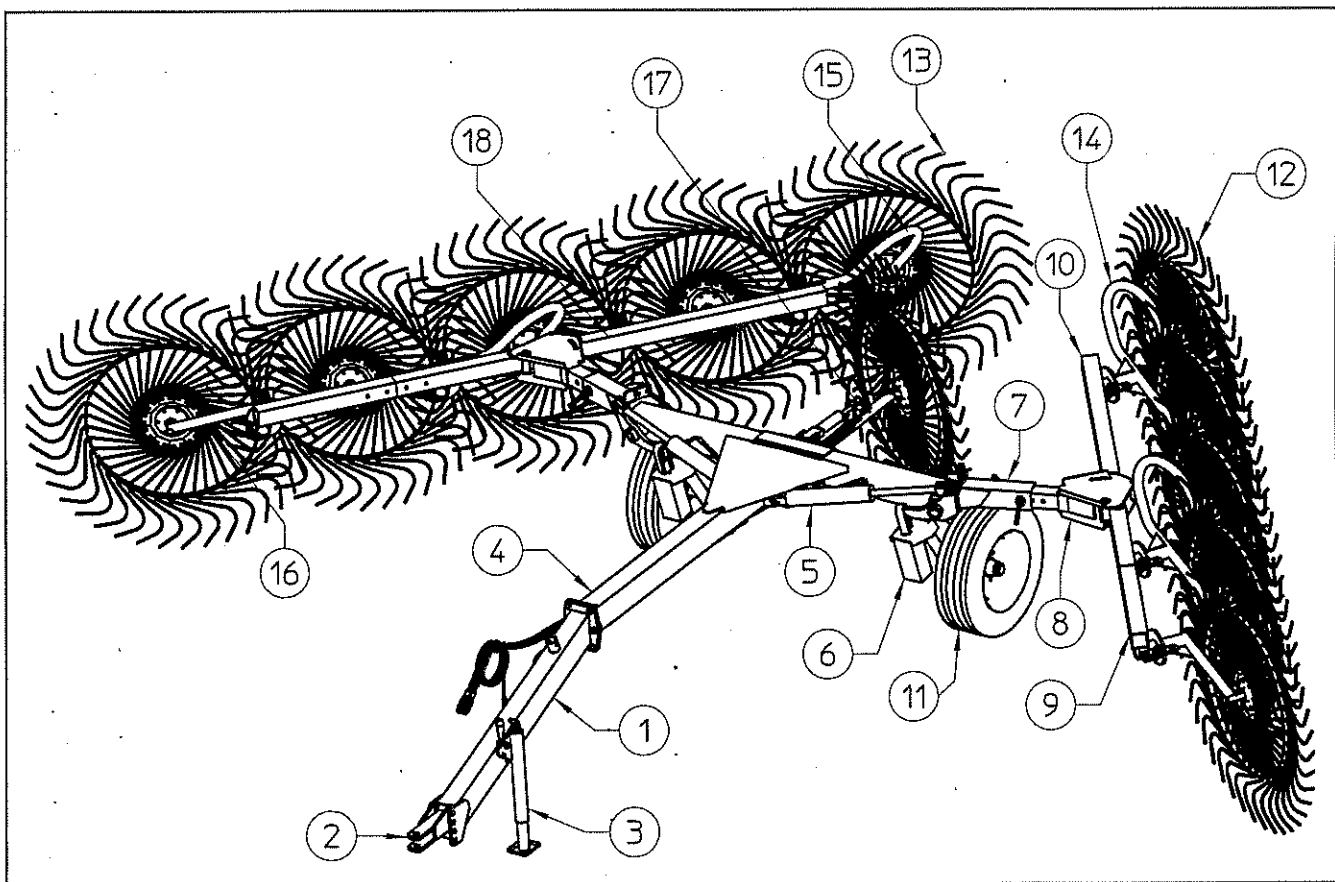

- | | |
|--------------------|---------------------------------|
| 1) DRAWBAR | 11) TIRE ASSY |
| 2) BRACKET | 12) WHEEL ASSY L.H. |
| 3) PARKING STAND | 13) WHEEL ASSY R.H. |
| 4) DRAWBAR | 14) WHEEL ARM L.H. |
| 5) CYLINDERS | 15) WHEEL ARM R.H. |
| 6) SPRING | 16) SINGLE ARM |
| 7) ARM | 17) CENTER WHEEL KIT (optional) |
| 8) TELESCOPIC ARM | 18) MAIN PIPE R.H. |
| 9) PIPE | |
| 10) MAIN PIPE L.H. | |

TECHNICAL SPECIFICATIONS

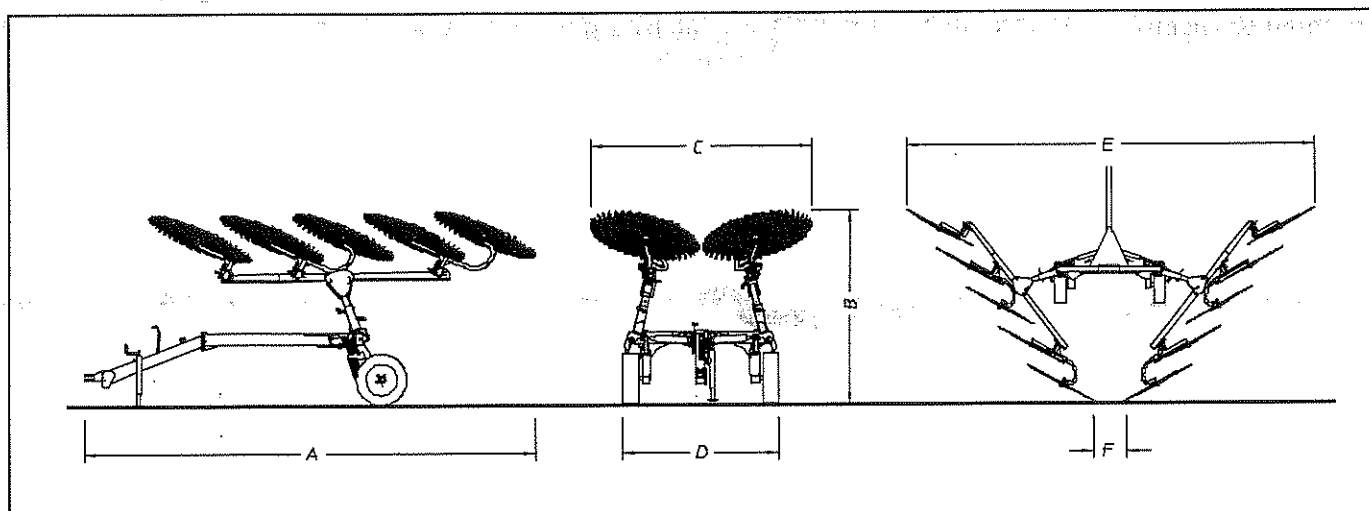

MODEL	QR 8	QR 10	QR 12
Number of Finger Wheels	8	10	12
Overall length ¹ (A)	19' (5,8 m)	19' (5,8 m)	21' 8" (6,6 m)
Minimum Transport Height (B)	7' 9" (2,4 m)	7' 9" (2,4 m)	7' 14" (2,5 m)
Transport Width (C)	9' 4" (2,8 m)	9' 4" (2,8 m)	9' 4" (2,8 m)
Width (D)	6' 6" (1,98 m)	6' 6" (1,98 m)	6' 6" (1,98 m)
Minimum Working Width ¹ (E)	16' 4" (5 m)	19' (5,8 m)	21' 8" (6,6 m)
Maximum Working Width ¹	19' (5,8 m)	22' (6,7 m)	25' 7" (7,8 m)
Minimum Windrow Width ¹ (F)	3' (0,9 m)	3' (0,9 m)	3' (0,9 m)
Maximum Windrow Width ¹	6' 7" (2 m)	6' 7" (2 m)	6' 7" (2 m)
Weight	1500 Lbs – 675 kg	1630 Lbs – 740 kg	1830 Lbs – 830 kg
Tires	205-75/15	205-75/15	205-75/15
Tractor Requirements HP	30 (22,3 KW)	30 (22,3 KW)	50 (36,7 KW)

(1) Depending on crop conditions

Adjustments for machine use

The machine must be adjusted according to the specific work requirements. Thus the various adjustment possibilities will be described, so you can choose that which best suits your work requirements. Before attaching the machine, make sure that it cannot accidentally start moving (chock the wheels).

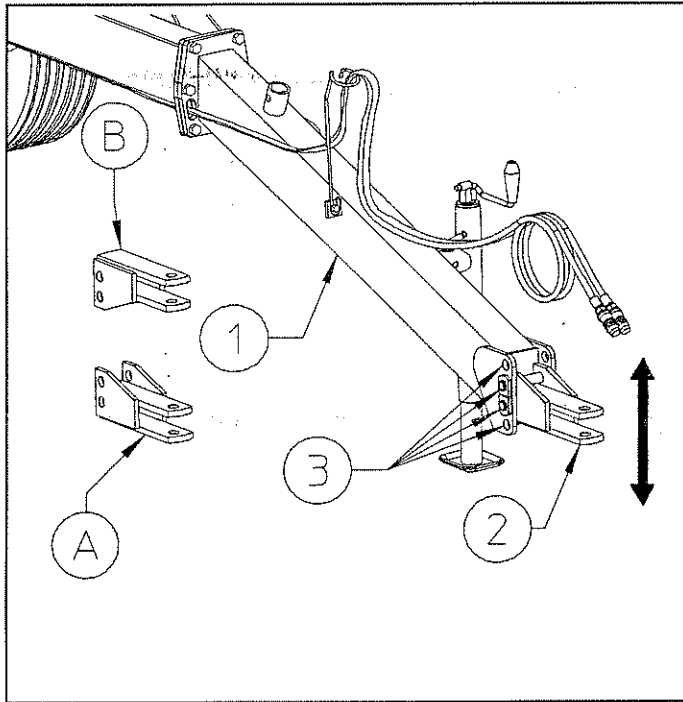

The tractor hitch must be adapted to the tow hook on the tractor.

The tractor hitch (2) can be set in different positions, using holes (3), to allow coupling to all tractor types. By turning the hitch upside-down from (A) to (B), additional settings are available.

Coupling the machine

Couple machine to tractor and secure hitch pin. Hitch pin should be 1 in. (25.4mm) diameter.

Raise parking stand crank handle, remove pin and jack.

Fasten parking stand into the transport position using pin and clip.

Danger : Before carrying out any maintenance, adjustments or repairs on the machine, switch off the tractor engine, remove ignition key, wait until all moving parts have come to a standstill.

Uncoupling the machine

Attention - Park the machine on even fairly level ground

Preferably park the machine in transport position with the transport lock installed.

- Block the machine with wheel chocks.
- Disconnect hydraulic hoses.
- Store hydraulic hoses in their support.
- Unhook safety chain. (If so equipped)

To prevent the implement hitch from raising rapidly, always position rake arms up against the stops or down with the finger wheels on the ground to prevent the rake from becoming unbalanced and tipping back when uncoupling.

- Remove parking stand to transport position.
- Install parking stand on tongue jack mount.
- Secure parking stand with pin and clip.
- Turn parking handle to lower the jack base to the ground and keep turning until the tongue weight is off of the tractor hitch (2).
- Remove hitch pin.

Machine is uncoupled.

When parking the machine for a long period, we recommend raising the rake arms until they butt against their stop in order to depressurize the hydraulic circuit.

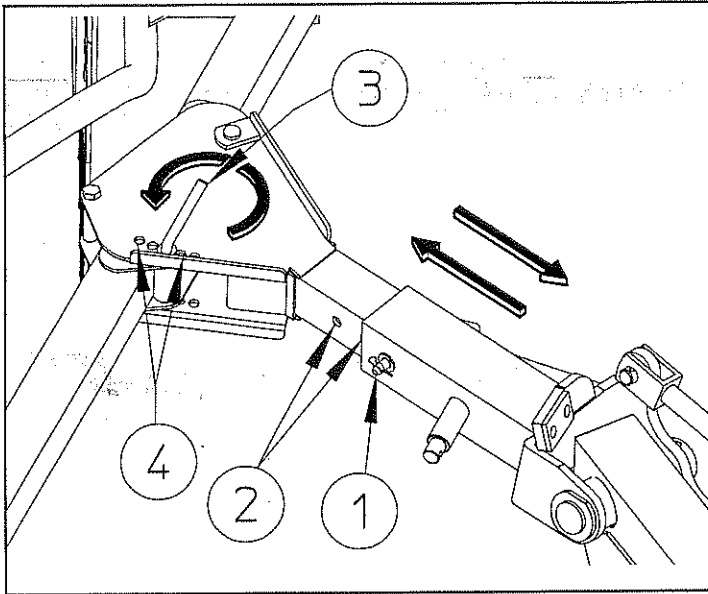

Setting working width

Working width can be adjusted by sliding the telescopic arm in or out. This will change the windrow width but not effect the rake arm angle

To change working width:

Remove pin (1).

Slide the telescoping arm to the desired position

Install pin (1) to lock the telescoping arm (1) in place.

Secure pin (1) with retaining clip.

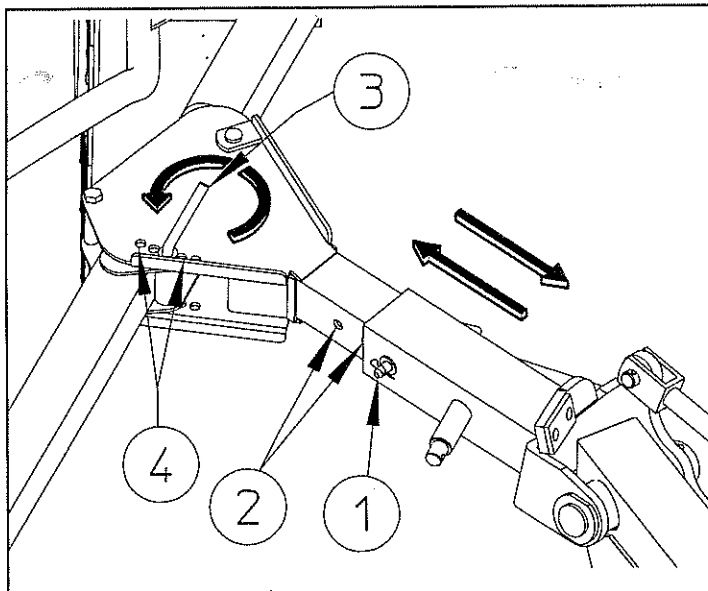

Setting rake arm angle

The hay rake arms can be pivoted and locked into different positions using pin (3). Change the rake wheel angle by rotating hay rake arms.

The hay rake arm can be pivoted to obtain a different working angle and further variation of the swath. Pin (3) is inserted in the different holes in quadrant (4) and fastened with the clip. The central position is the best for most working conditions.

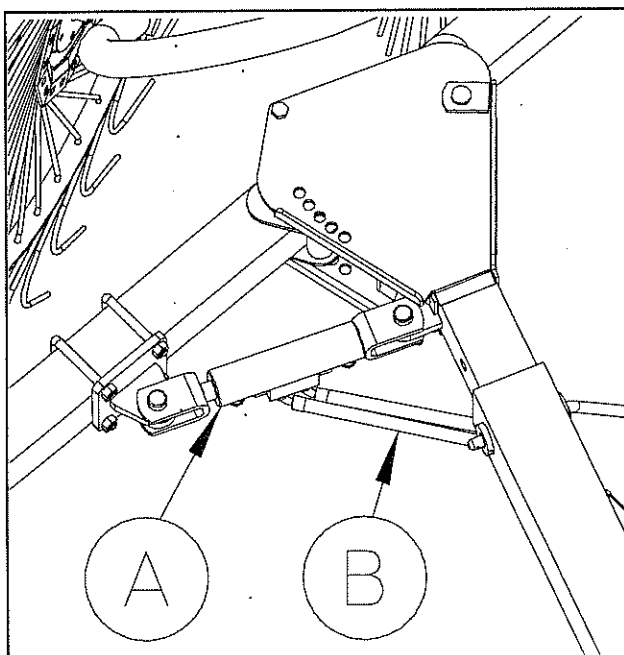

OPTIONAL

A hydraulic opening kit is available for adjusting the working angle.

With the hydraulic opening the pin for adjusting and locking the working angle is removed. Two cylinders (A) are fitted, which are controlled by the pipes (B), making it possible to obtain the desired section angle position without getting down from the tractor.

Adjusting rake ground pressure

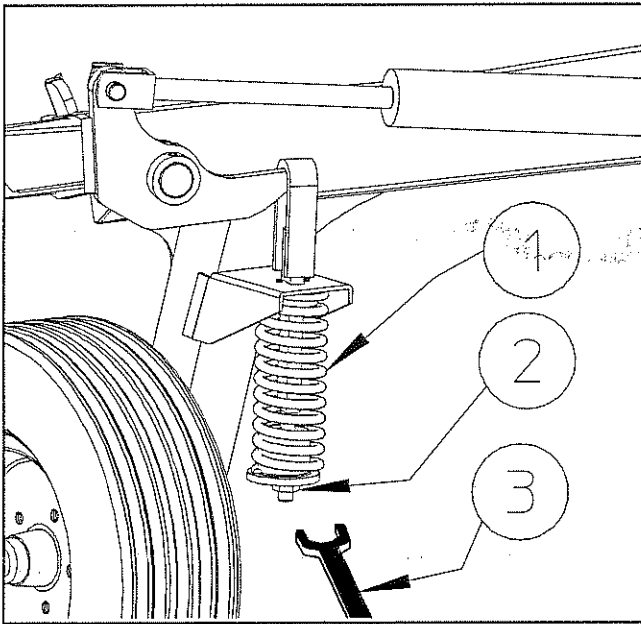

The pressure of the rake wheels on the ground can be regulated also by suspension springs (1)

- Activate tractor hydraulic valve to lower the rake arms to their stops.

- Adjust the tine wheel ground pressure by turning adjusting nut (2).

- Compressing the spring reduces tine wheel ground pressure.

- Reducing compression increases tine wheel ground pressure.

- Note: As a starting point before adjusting ground pressure the nut must be screwed onto the tie rod so that a threaded section 6 mm (1/4") protrudes. By having a longer section of the screws protrude (thus shortening the spring), the weight of the rake wheels on the ground is decreased.

The rake wheels are driven by contacting the ground. Adjust the wheel ground pressure for good raking action without damaging the crop.

Ground speed affects raking performance. Be sure to operate the rake at recommended raking ground speeds when checking ground pressure.

Transport by road

Attention:

When the hay rake arms are lifted, the shape of the hinges carries the weight toward the tractor and makes it possible to decrease the machine dimensions.

Check carefully during the lifting stage to make sure that parts of the machine do not touch parts of the tractor.

Check to make sure that with certain tractors during transport operations, while steering or when moving over uneven ground the hay rake arms do not touch parts of the tractor, with the risk of causing damage to both machines.

If it is possible that there may be contact between parts of the hay rake and parts of the tractor, it is recommended that the angle of the arms be increased before lifting them. This operation brings them farther away from the tractor and creates a situation of greater safety.

Danger: Crushing hazard

Keep a safe distance from machine when raising or lowering arms, or when implement is in transport position.

Lock arms in raised position before transport and before working under this machine.

Before placing the machine into transport position:

Make sure the rotating parts have come to a complete stop. Check and move away any person located in the rake arm pivoting area.

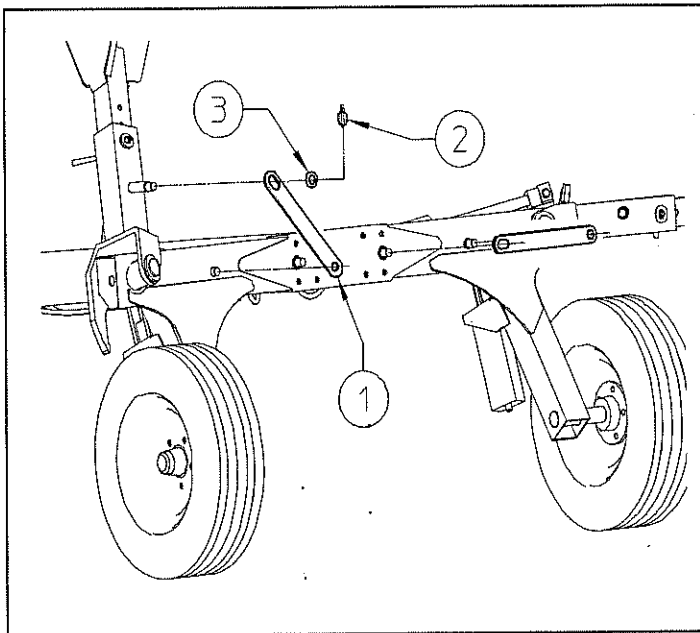

Set the machine into transport position.

From the working position:

- Activate the tractor hydraulics and raise the rake arms until they reach the stops.
- Install the transport safety arm (1) to the transport position on the pins.
- Secure the transport safety arm (1) with the retaining pins (2).
- Make sure that all safety signs and reflectors are installed, clean and visible.

Do not operate tractor hydraulics while in transport position.

Conformity with the road regulations

Before driving the machine on public roads, ensure that the machine meets current highway code regulations. If the machine is over the maximum legal size, follow the local regulations for special transports of oversize equipment.

Check that the reflecting signalling panels are clean and that any lighting equipment functions before going on public roads.

Before going on public roads:

- Make sure rake arms are locked.
- Make sure the hitch pin is installed with the lock pin secured.

Immediately replace any worn or damaged signalling panels or lights.

Instructions for work

DANGER - Before placing machine in work position:
Check that nobody is within the machine pivoting area.
If there is someone, make sure the person moves away.

Setting the machine into work position

From the transport position:

- Stop tractor engine and remove the key.
- Remove the transport safety arm (1) from the transport locked position.
- Install the transport safety arm to work position (horizontal)
- Install the retaining pin (2) and washer (3) to secure the transport safety arm (1).
- Get back on the tractor and lower the rake arms to the working position with the hydraulic cylinder.

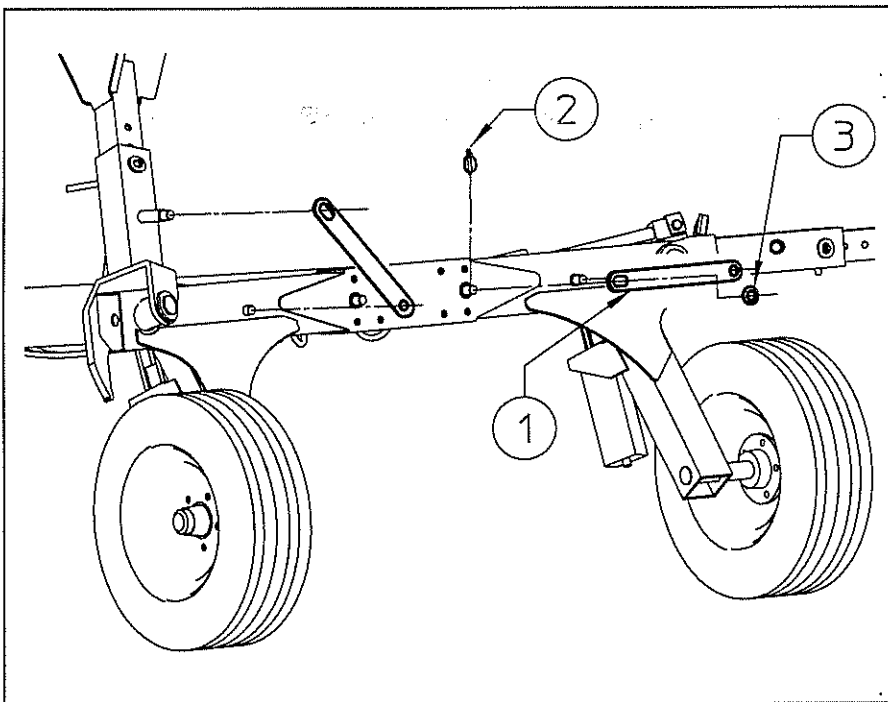

The machine is in working position.

The tractor hydraulics must be set to float mode during operation

Adjustment in work position

Minimum and maximum width and windrow specifications

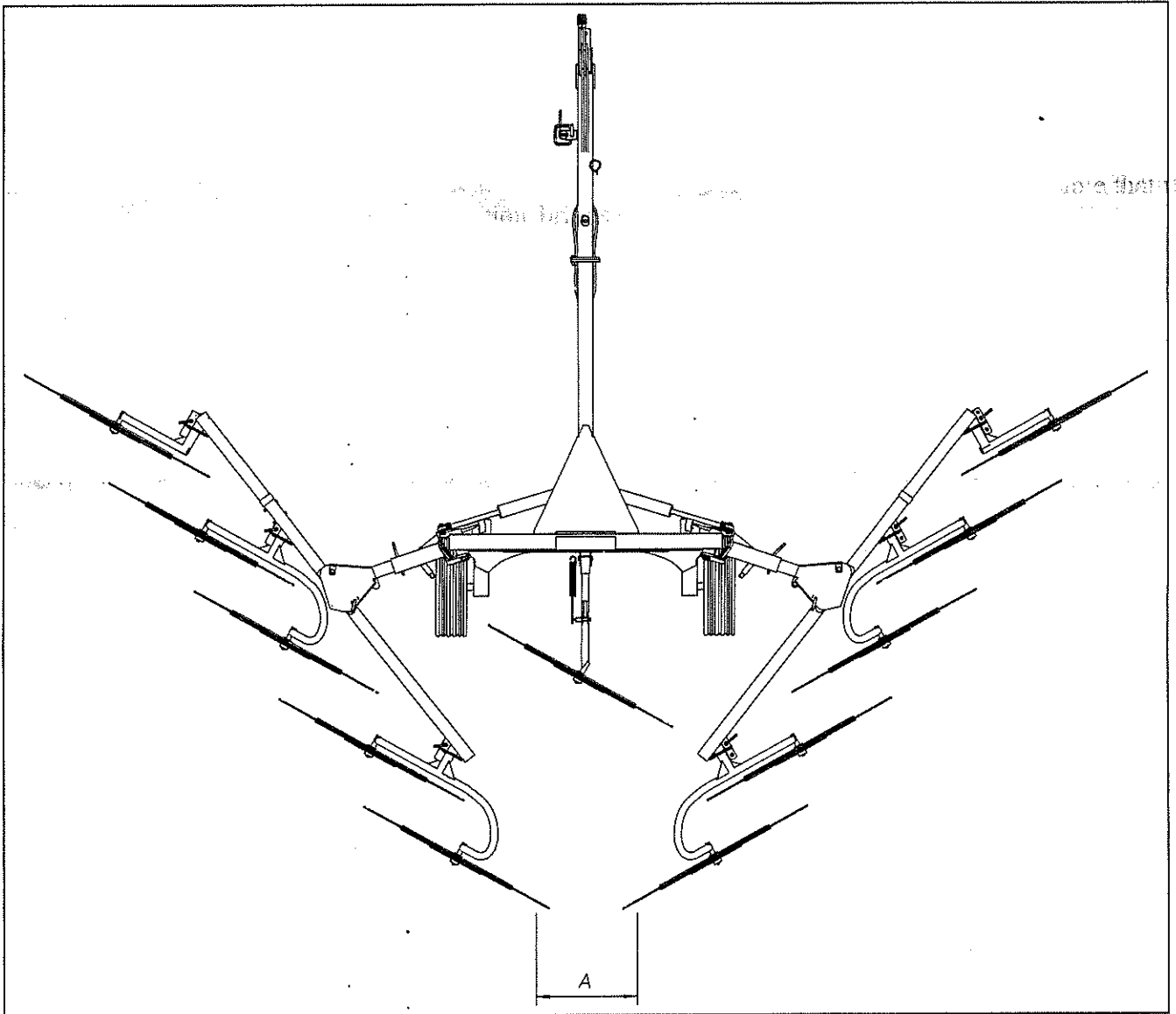

MODEL	QR 8	QR 10	QR 12
Minimum Windrow Width (A)	3' (0,9 m)	3' (0,9 m)	3' (0,9 m)
Maximum Windrow Width (A)	6' 7" (2 m)	6' 7" (2 m)	6' 7" (2 m)
Minimum Working Width	16' 4" (5 m)	19' (5,8 m)	21' 8" (6,6 m)
Maximum Working Width	19' (5,8 m)	22' (6,7 m)	25' 7" (7,8 m)

will vary depending on crop conditions.

DANGER - Before placing machine in work position:
Check that nobody is within the machine pivoting area.
If there is someone, make sure the person moves away.

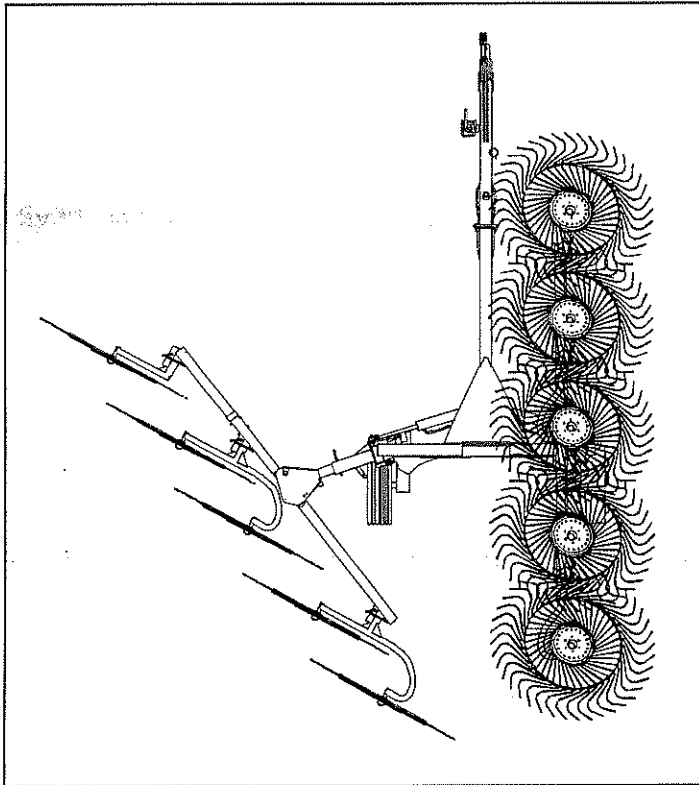

For raking on one side only:

Stop the tractor engine and remove the key

Remove the transport safety arm only on the side on which you want to work.
Lock the transport safety arm in the resting position (horizontal).

Install the retaining pin and washer.

Get back on the tractor and lower the hay rake arm with the hydraulic cylinder.

On the side where you have left the transport arm the hay rake arm will remain raised.

Once the arm has gone over center, place the tractor hydraulics into the float position, allowing the rake arms to finish lowering

The machine is ready to work on one side only.

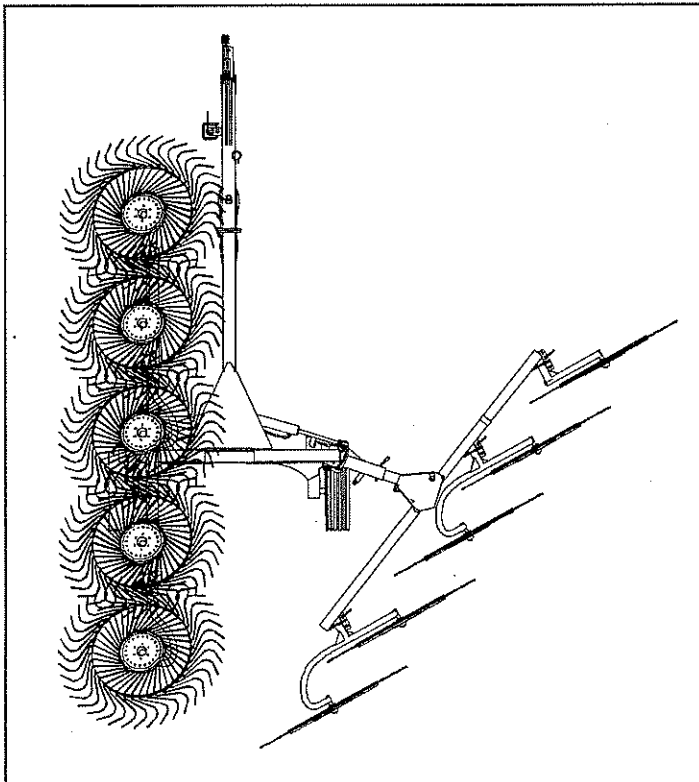

General maintenance instructions

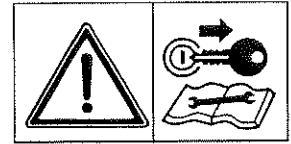
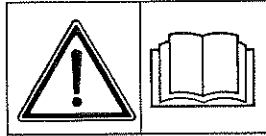
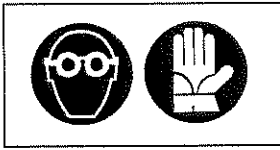

Repair work

Any repair work must be carried out with the machine at rest and disconnected from the tractor. Do not carry out welding without authorisation and instructions from the manufacturers. Rest the machine on the ground, release the pressure from the hydraulic circuit and leave the machine to cool down. Repairs on elements under pressure or tension (springs, pressure accumulators, etc.) must only be carried out by competent persons with regulation equipment. Wear the appropriate protective clothing for the work in hand. Disconnect the machine from the tractor before any welding work in order not to damage the battery. Always use a protective mask, goggles and gloves when welding, sanding or grinding or when using a hammer or drill. Always work on the machine out of doors. If you have to operate the machine when connected to the tractor in an enclosed area (for example when testing after repair and/or maintenance), ensure that there is sufficient ventilation so as to prevent noxious exhaust gases accumulating. In order to acquire the necessary control and to operate in safety, practise various manoeuvres by simulating those required in the workplace with the help of an experienced person.

Laying up for extended periods

At the end of the season, or when an extended period of inactivity is envisaged, it is advisable to:

- 1) clean the machine following instructions and allow it to dry;
- 2) check it carefully and replace any damaged or worn parts;
- 3) thoroughly tighten all screws and bolts;
- 4) grease the machine thoroughly and then cover it completely and lay it up in a dry place.

It is to the users advantage to carry out these operations carefully. In this way, he will have a machine in perfect condition when work is restarted.

On restarting work, repeat all the proper checks so as to be certain of working in conditions of maximum safety.

IMPORTANT

During extended periods of inactivity.

The rods parts remaining outside the cylinder pipe must be carefully protected with a grease layer.

Maintenance direction

All cleaning, lubrication and maintenance operations must be carried out with the machine disconnected from the tractor.

In an emergency with the machine still connected to the tractor, switch off the engine, apply the parking brake, and remove the ignition key from the instrument panel.

Regular, correct maintenance and proper operation are the basic prerequisites for the long-term efficiency and safe operation of the machine.

Pay special attention to all instructions given on signs located on the machine.

All maintenance should be carried out in an area having the proper equipment readily available and in good condition. This area must always be kept clean and dry and must have enough surrounding space to facilitate operations.

Any work must be carried out by trained personnel. Contact the dealer nearest to you.

Respect the warnings and procedure for maintenance and technical assistance given in this manual.

Do not use petrol, solvents or other flammable liquids as detergents.

Use commercial non-flammable and non-toxic solvents, authorised by competent bodies.

Do not use compressed air or water at high pressure to clean the machine. If this is unavoidable, then wear goggles with side protection and limit the pressure as much as possible. When the work is finished, and with the machine disconnected from the tractor, inspect and check the machine completely.

After the first 10 hours of use

Check tightness of all bolt and nuts, particularly on wheels

Tires

Regularly check the tire pressure. Respect manufacturer's recommendations on tire pressure.

Assembly, disassembly and repair of wheels and tires must only be carried out by competent persons

Hydraulic circuit

Beware! The hydraulic circuit is under pressure. Maximum pressure at work: 3000 psi (200 bar).

Before connecting hoses to the tractor hydraulics, ensure that tractor and machine circuits are not under pressure. Before disconnecting a hose, depressurize the hydraulic circuit.

To avoid making wrong connections, mark hydraulic couplers and corresponding hoses with colors.

WARNING! Functions could be reversed (for example: lift/lower) and cause accidents.

Regularly check the hydraulic hoses. In case of normal wear, replace the hydraulic hoses every 5 years. Damaged or worn hoses must immediately be replaced. When replacing the hydraulic hoses, make sure to use hoses with the specifications and quality recommended by the manufacturer of the machine.

To locate a leak, use appropriate means. Protect body and hands from liquid under pressure. Use paper or cardboard to check for leaks. Never use your hand. If oil penetrates skin, gangrene or other serious injury could occur. Get immediate medical attention.

Any liquid under pressure (particularly oil from hydraulics) can penetrate the skin and cause severe injury. If injured, see a doctor immediately, there could be danger of infection.

Before any adjustments, maintenance or repairs are carried out, lower the machine on the ground, depressurize the hydraulics, turn off the engine, remove ignition key and wait until all moving parts have come to a complete stop.

Lubrication

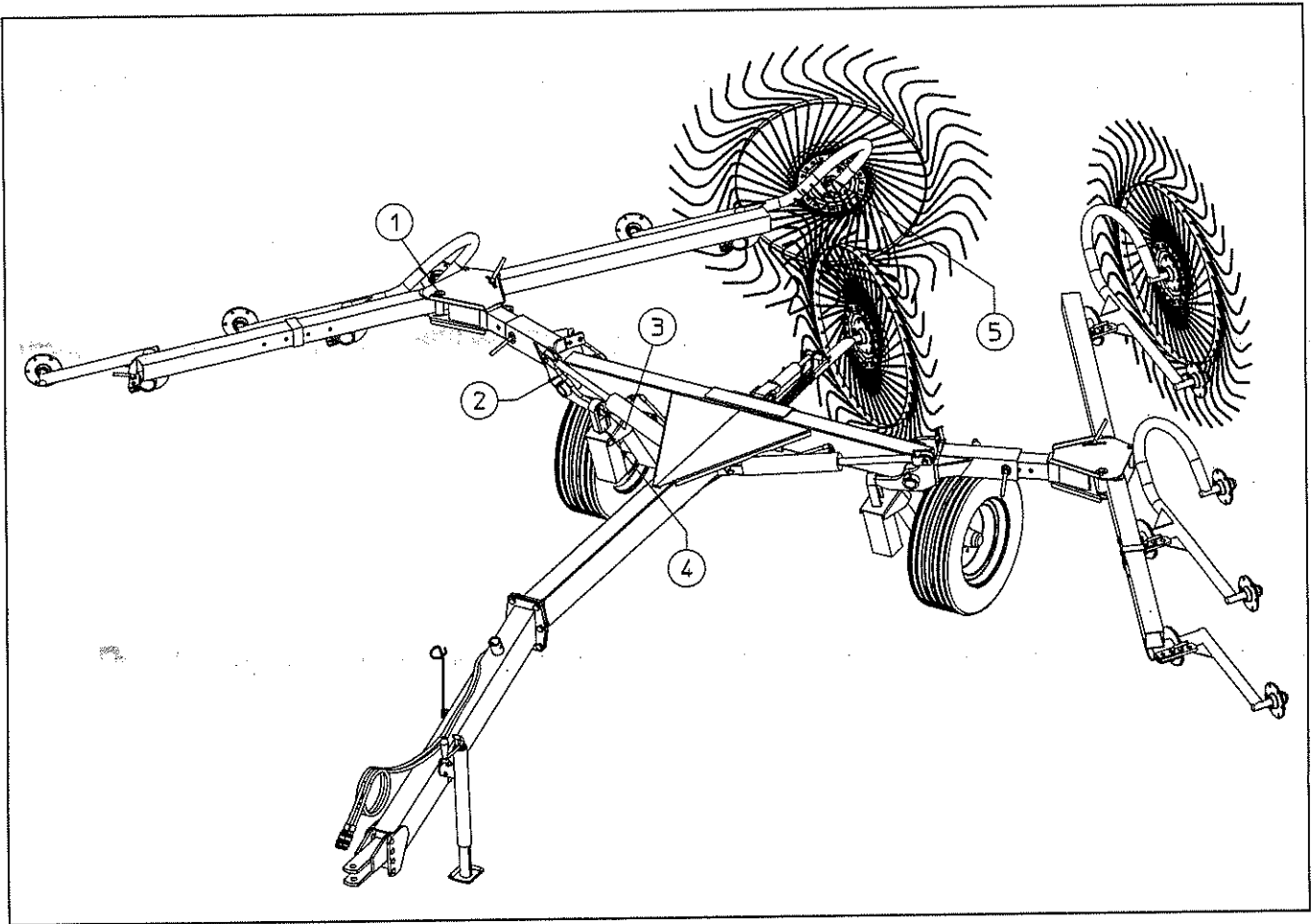

Every 25 hours

- Pin (1)
- Pin (2)
- Sliding (4)
- Hook (3)

Every 40 hours

- wheel hubs (5)

At the start of each season

Read the operator's manual.

Check tire pressure.

Lubricate all grease points.

Torque transport wheel lug nuts. 120 ft. lbs. (16.3 daNm)

THE FOLLOWING SHOULD BE NOTED IF THE MACHINE IS SCRAPPED:

The machine consists mainly of ferrous material which must be disposed of according to the regulations in force in the country concerned.

There is also a small amount of plastic which must be disposed of according to the regulations in force in the country concerned.

Optional Center Rake Wheel Kit

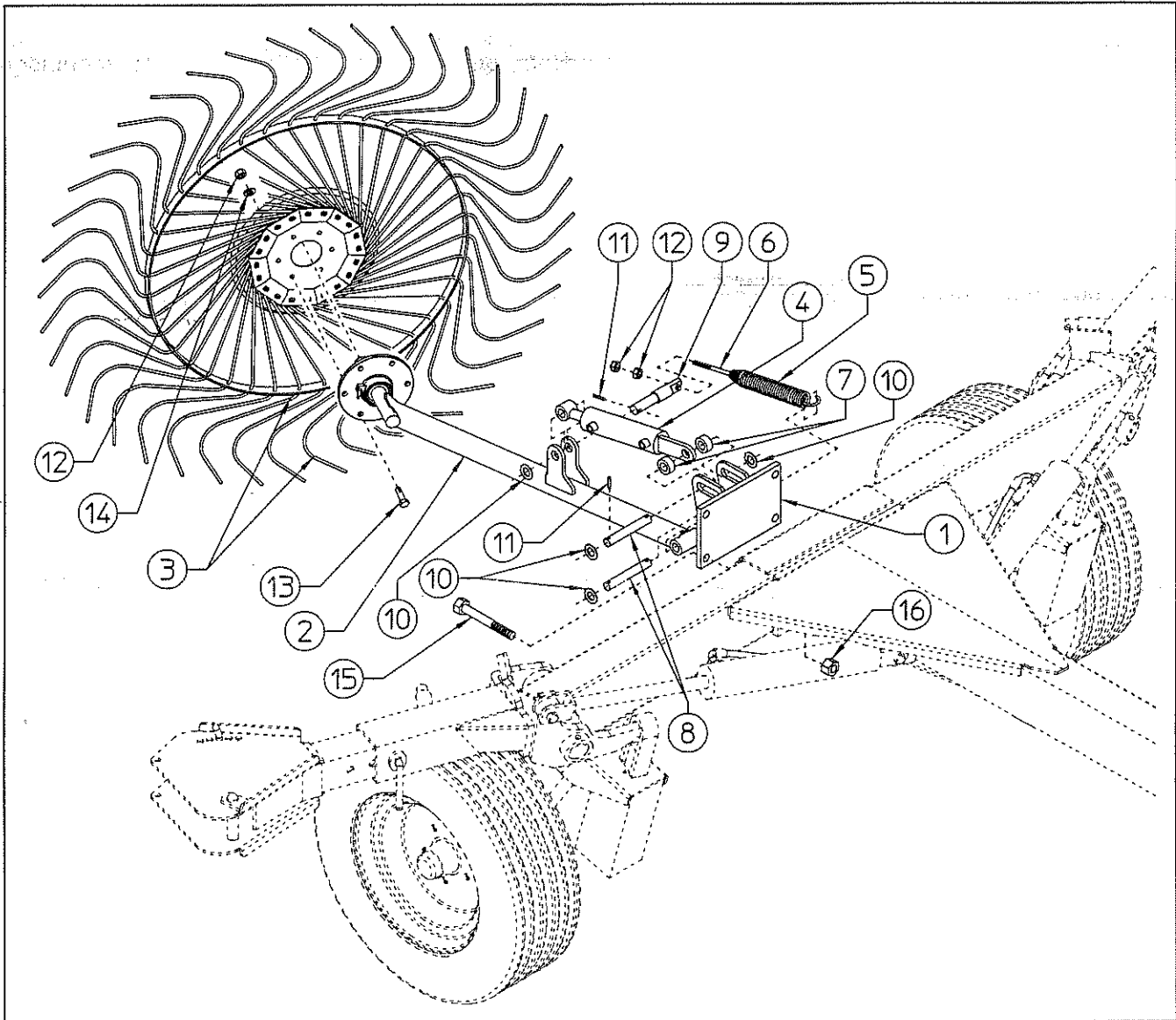

To assemble the Center Rake Wheel Kit, proceed as follows:

Remove the four central screws that connect the horizontal drawbar to the main frame and attach the plate (1) using the 4 long screws (15) that are supplied and the nuts (16).

Assemble the arm (2) and hydraulic cylinder (4) to the plate (1) using the two pins (8), the washers (10) and the spring pins (11).

Connect the arm and cylinder with the milled pin (9), the washer (10) and the spring pin (11).

Attach the spring (5) first with the hook in the hole in the plate (1) and then the screw (6) in the hole in the milled pin (9). Tighten the nuts (12) on the screw, letting a few millimeters (1/8") protrude. The spring tension must be adjusted later according to the desired pressure of the rake wheel on the ground.

Attach the rake wheel (3) to the arm (2) using the screws (13), washers (14) and nuts (12).

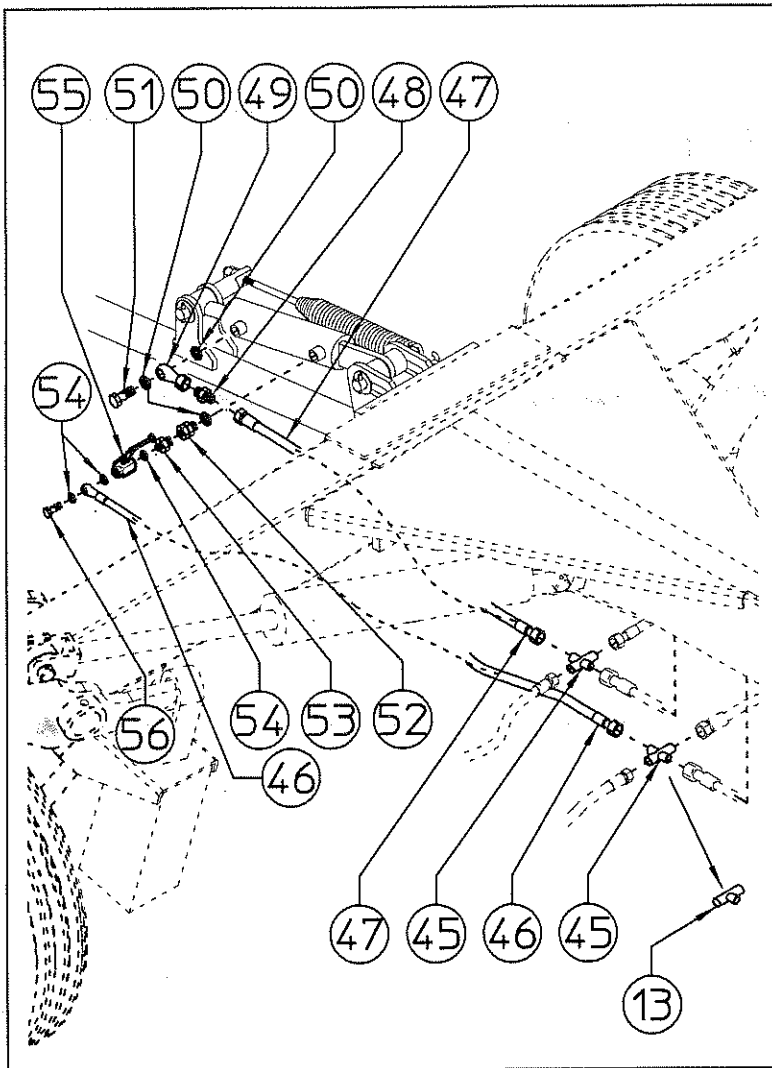

Assembly of hydraulic system for center rake wheel kit.

Attention: before proceeding check to make sure the hydraulic circuit is not under pressure. Wear individual protective devices (gloves, safety goggles, etc.). When loosening the fittings work carefully and cautiously. Remove the tee fittings (13) found and replace them with the crosses (45). Attach the short pipe (47) to the head of the cylinder using the coupling (51) and the washers (50); on the machine side connect the coupling nearest to the rake wheel kit (see figure).

Attach the fittings (52) and (53) to the base side of the cylinder with the valve (55) using the seal washers (50) and (54).

Attach to the valve (55) the long pipe (46), to be connected to the cross (45) far away from the rake wheel kit.

The center rake wheel kit must be used to move the product to be raked into the center area before forming the swath.

The hydraulic cylinder is operated in parallel with the rake arms and therefore no additional operations are required. The center rake wheel normally moves very fast; this does not mean it is not working properly. The compensating spring must be adjusted with the two nuts on the screw so as to obtain the right ground pressure according to the desired working conditions.

Tighten the nut to decrease ground pressure.

Loosen the nut to increase ground pressure.

If the raking conditions do not require the use of the center rake wheel the valve (55) makes it possible to keep the arm from lowering.

To lock out the central wheel kit:

Activate the tractor hydraulics and raise the rake arms until they reach the stops.

Stop the tractor engine and remove the key.

Wait until all moving parts have stopped.

Close the hydraulic valve (55) at the rear of the rake.

1. Introduction

2. Methodology

3. Results and Discussion

4. Conclusion

5. References

SPARE PARTS LIST

TABLE PART NO 920.261 QR/8-10-12

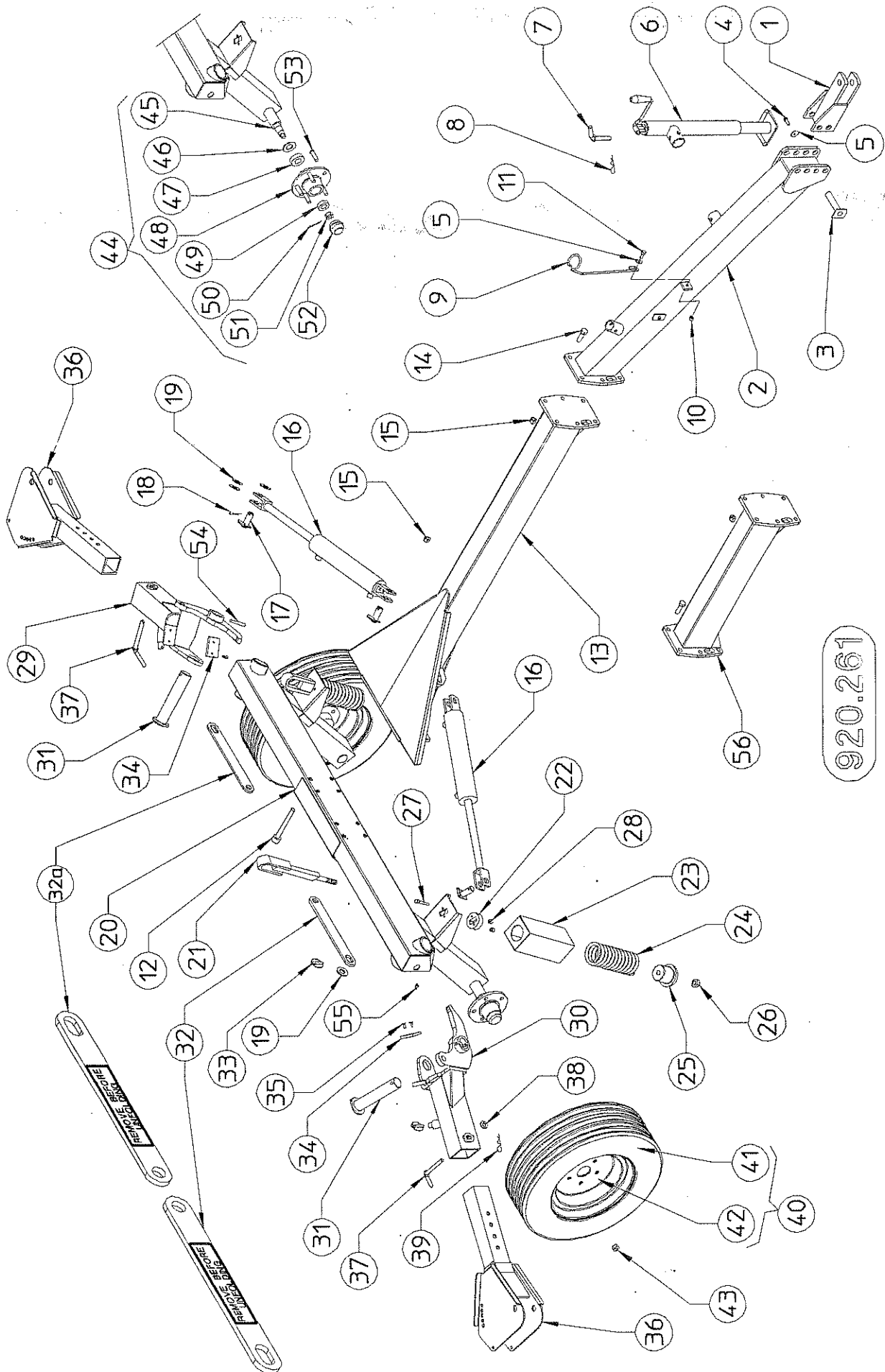

920.261

TABLE PART NO 920.261				
ITEM	Q.ty	PART NO	DESCRIPTION	NOTE
1	1	230.370	BRACKET	
2	1	230.296	DRAWBAR	
3	2	200.828	PIN	
4	2	600.770	SCREW M12 X 20 DIN 933 8.8	
5	3	600.092	WASHER Ø12x36	
6	1	220.197	PARKING STAND	
7	1	200.222	PIN	
8	1	600.019	SPLIT PIN BC3	
9	1	110.105	SUPPORT	
10	1	600.077	NUT M12 DIN 980	
11	1	600.616	SCREW M12 X 35 DIN 933 8.8	
12	8	600.595	SCREW M16 X 140 DIN 931 8.8	
13	1	230.297	DRAWBAR	
14	6*	600.176	SCREW M16 X 50 DIN 931 8.8	*For QR12 Q.ty 12
15	14*	600.080	NUT M16 DIN 980	*For QR12 Q.ty 20
16	2	230.302	CYLINDER	
17	4	230.368	PIN	
18	4	600.038	SPLIT PIN D 6 X 35 DIN 94 3.6	
19	16	600.336	WASHER Ø25 DIN 125A	
20	1	230.298	CART FRAME	
21	2	230.299	TIE ROD	
22	2	230.333	SLIDING	
23	2	230.369	HOOD	
24	2	230.300	SPRING	
25	2	230.310	BUSH	
26	2	600.717	NUT M20 DIN 980	
27	4	600.551	SCREW M8 X 35 DIN 931 8.8	
28	4	600.076	NUT M8 DIN 980	
29	1	230.303	L.H. ARM	
30	1	230.304	R.H. ARM	
31	2	230.319	PIN	
32	1	230.387	RH TRANSPORT ARM WITH LABEL	
32a	1	230.388	LH TRANSPORT ARM WITH LABEL	
33	4	600.116	SPRING PIN BS8	
34	2	230.360	BLOCK	
35	4	610.496	SCREW M8 X 20 similar to DIN7991	
36	2	230.305	ARM	
37	2	230.331	PIN	
38	2	610.595	WASHER D 15,3	
39	2	600.308	SPLIT PIN BC4	
40	2	600.281	TIRE ASSY	
41	2	600.303	TIRE	
42	2	600.304	RIM	
43	10	600.289	NUT M16 X 1,5	
44	2	215.960	HUB ASSY	
45	2	215.959	HUB PIN	
46	2	600.284	DUST COVER	
47	2	600.285	BEARING 30208	
48	2	600.286	HUB	
49	2	600.287	BEARING 30206	
50	2	600.291	SPLIT PIN D.4 X 40 DIN 94 3.6	
51	2	600.288	NUT M27 X 1,5	
52	2	600.290	CAP	
53	2	610.413	SCREW M16 X 1,5	
54	2	600.656	SPRING PIN D.12 X 70 DIN 1481	
55	2	600.034	GREASE NIPPLE M8	
56	1	230.367	DRAWBAR	QR12 only

TABLE PART NO 920.263 QR/8-10

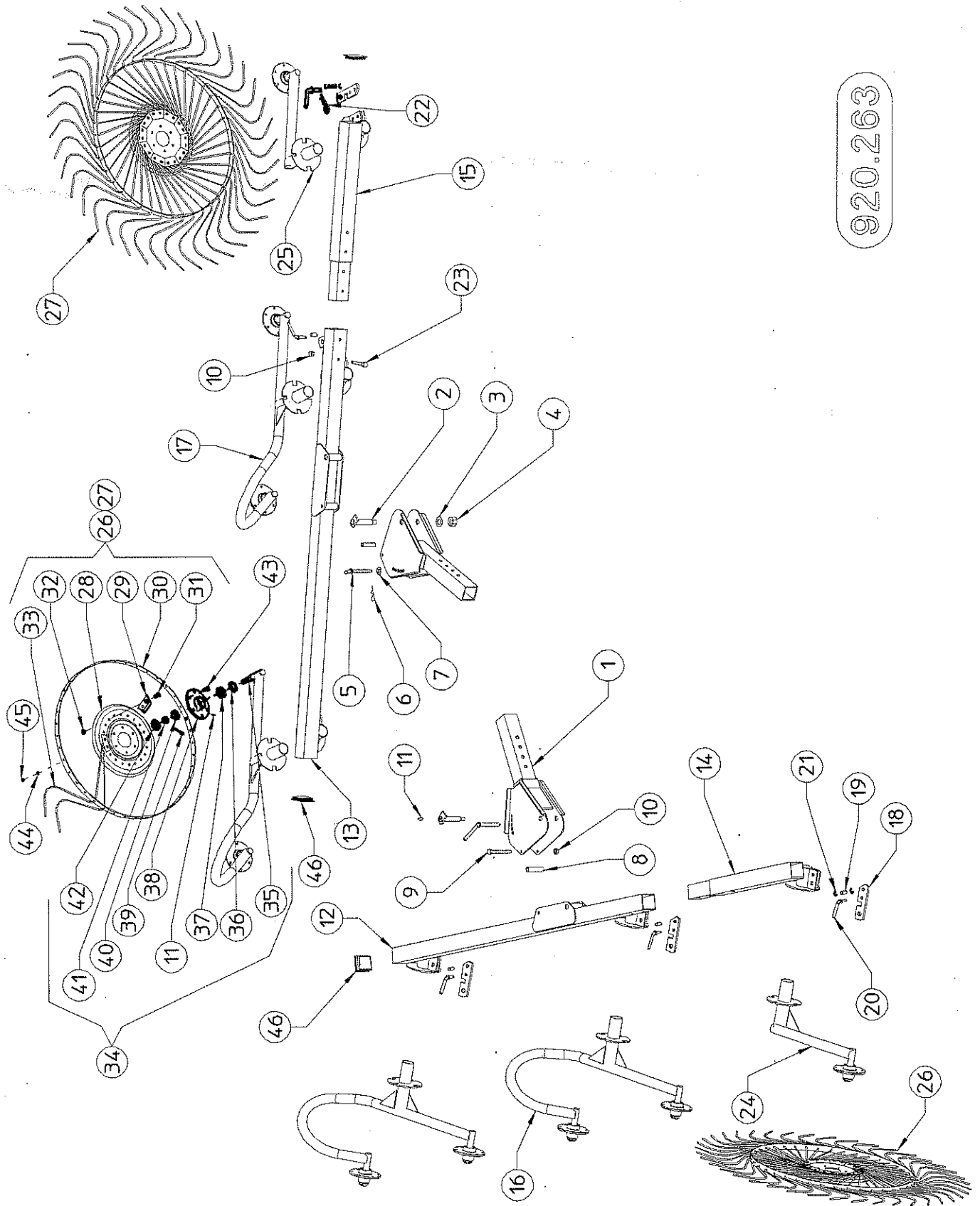

920.263

TABLE PART NO 920.263

ITEM	Q.ty	PART NO	DESCRIPTION	NOTE
1	2	230.305	ARM	
2	2	230.329	PIN	
3	2	600.632	WASHER Ø21 DIN 125A	
4	2	600.717	NUT M20 DIN 980	
5	2	230.330	PIN	
6	2	600.308	SPLIT PIN BC4	
7	2	610.595	WASHER D 15,3	
8	2	230.309	BUSH	
9	2	600.225	SCREW M12 X 120 DIN 931 8.8	
10	6	600.077	NUT M12 DIN 980	
11	12*	600.034	GREASE NIPPLE M8	*For QR8 Q.ty 10
12	1	230.307	MAIN PIPE R.H.	
13	1	230.308	MAIN PIPE L.H.	
14	1*	230.353	PIPE R.H.	*QR10 only
15	1*	230.354	PIPE L.H.	*QR10 only
16	2	230.334	WHEEL ARM R.H.	
17	2	230.336	WHEEL ARM L.H.	
18	6*	200.073	LOCK DEVICE	*For QR8 Q.ty 4
19	6*	200.074	PIN	*For QR8 Q.ty 4
20	6*	200.075	PIN	*For QR8 Q.ty 4
21	12*	600.023	SNAP RING E15 DIN 471	*For QR8 Q.ty 8
22	6*	600.019	SPLIT PIN BC3	*For QR8 Q.ty 4
23	4*	610.516	SCREW M12 X 100 DIN 931 8.8	*QR10 only
24	1*	230.335	ARM R.H.	*QR10 only
25	1*	230.337	ARM L.H.	*QR10 only
26	5*	210.180	WHEEL ASSY R.H. (TINE DIA 0,276" 7mm)	*For QR8 Q.ty 4
27	5*	210.181	WHEEL ASSY L.H. (TINE DIA 0,276" 7mm)	*For QR8 Q.ty 4
28	10*	200.010	FLANGE	*For QR8 Q.ty 8
29	100*	200.012	TINE CLAMP	*For QR8 Q.ty 40
30	10*	200.009	RIM	*For QR8 Q.ty 8
31	200*	600.005	SCREW	*For QR8 Q.ty 160
32	200*	600.029	NUT M10 DIN 980	*For QR8 Q.ty 160
33	400*	210.621	TINE DIA 0,276" (7mm)	*For QR8 Q.ty 320
34	10*	205.041	HUB ASSY	*For QR8 Q.ty 8
35	10*	205.277	PIN	*For QR8 Q.ty 8
36	10*	600.011	DUST COVER	*For QR8 Q.ty 8
37	10*	600.012	BEARING 30205	*For QR8 Q.ty 8
38	10*	600.013	WHEEL HUB	*For QR8 Q.ty 8
39	10*	600.301	SPLIT PIN	*For QR8 Q.ty 8
40	10*	600.014	BEARING 30204	*For QR8 Q.ty 8
41	10*	600.015	SELF-LOCKING NUT M18X1,5 - 6	*For QR8 Q.ty 8
42	10*	600.016	SAFETY CAP	*For QR8 Q.ty 8
43	60*	600.006	SCREW M10 X 25 DIN 933 8.8	*For QR8 Q.ty 40
44	60*	600.024	SPRING WASHER D 10,5	*For QR8 Q.ty 40
45	60*	600.010	NUT M10 DIN 934 - 8	*For QR8 Q.ty 40
46	4	630.079	PLUG	

TABLE PART NO 920.264 QR/12

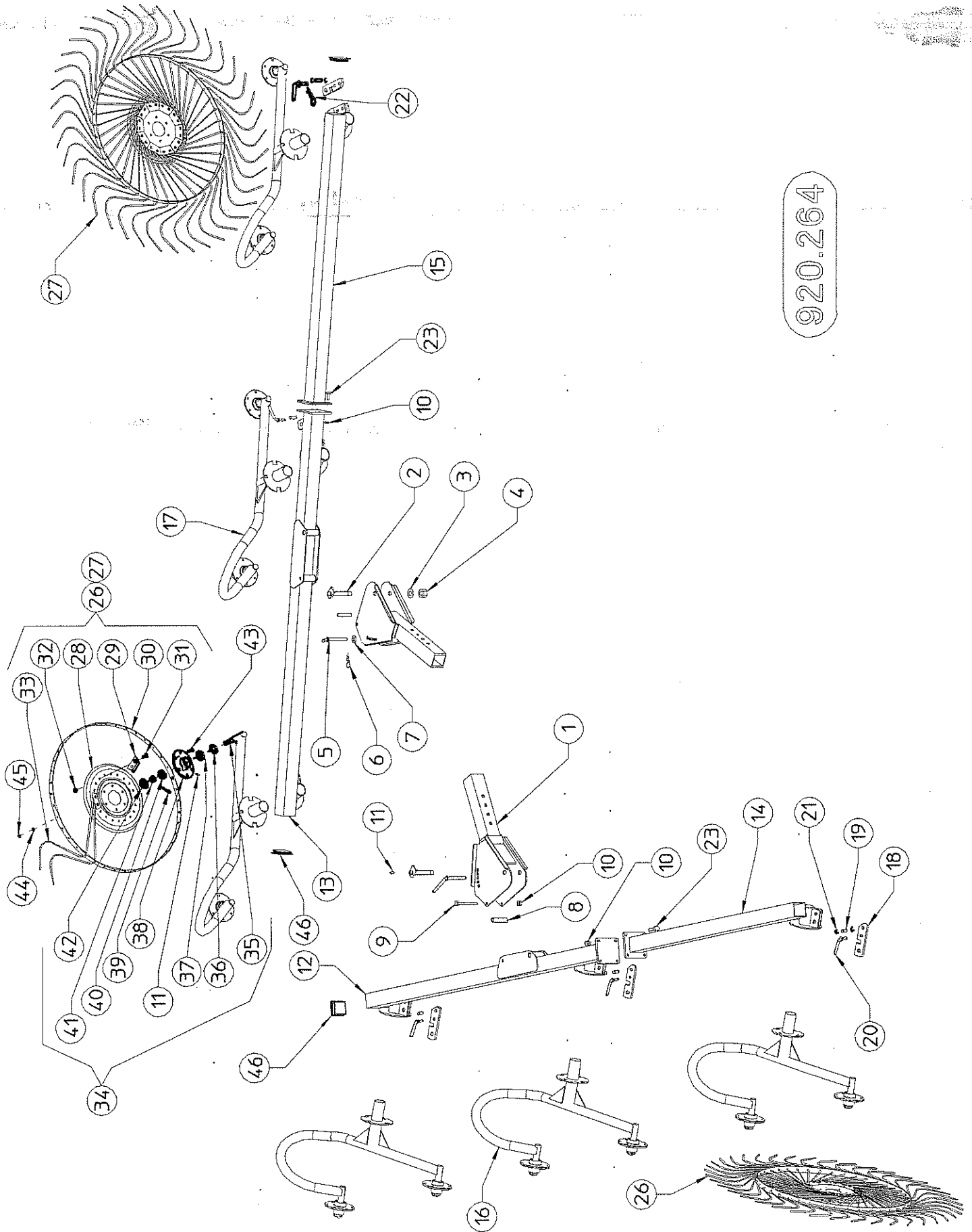

920.264

TABLE PART NO 920.264				
ITEM	Q.ty	PART NO	DESCRIPTION	NOTE
1	2	230.305	ARM	
2	2	230.329	PIN	
3	2	600.632	WASHER Ø21 DIN 125A	
4	2	600.717	NUT M20 DIN 980	
5	2	230.330	PIN	
6	2	600.308	SPLIT PIN BC4	
7	2	610.595	WASHER D 15,3	
8	2	230.309	BUSH	
9	2	600.225	SCREW M12 X 120 DIN 931 8.8	
10	10	600.077	NUT M12 DIN 980	
11	14	600.034	GREASE NIPPLE M8	
12	1	230.355	MAIN PIPE R.H.	
13	1	230.356	MAIN PIPE L.H.	
14	1	230.357	PIPE R.H.	
15	1	230.358	PIPE L.H.	
16	3	230.334	WHEEL ARM R.H.	
17	3	230.336	WHEEL ARM L.H.	
18	6	200.073	LOCK DEVICE	
19	6	200.074	PIN	
20	6	200.075	PIN	
21	12	600.023	SNAP RING E15 DIN 471	
22	6	600.019	SPLIT PIN BC3	
23	8	600.616	SCREW M12 X 35 DIN 933 8.8	
24				
25				
26	6	210.180	WHEEL ASSY R.H. (TINE DIA 0,276" 7mm)	
27	6	210.181	WHEEL ASSY L.H. (TINE DIA 0,276" 7mm)	
28	12	200.010	FLANGE	
29	120	200.012	TINE CLAMP	
30	12	200.009	RIM	
31	240	600.005	SCREW	
32	240	600.029	NUT M10 DIN 980	
33	480	210.621	TINE DIA 0,276" (7mm)	
34	12	205.041	HUB ASSY	
35	12	205.277	PIN	
36	12	600.011	DUST COVER	
37	12	600.012	BEARING 30205	
38	12	600.013	WHEEL HUB	
39	12	600.301	SPLIT PIN	
40	12	600.014	BEARING 30204	
41	12	600.015	SELF-LOCKING NUT M18X1,5 - 6	
42	12	600.016	SAFETY CAP	
43	72	600.006	SCREW M10 X 25 DIN 933 8.8	
44	72	600.024	SPRING WASHER D 10,5	
45	72	600.010	NUT M10 DIN 934 - 8	
46	4	630.079	PLUG	

PART NO 920.262 QR/8-10-12

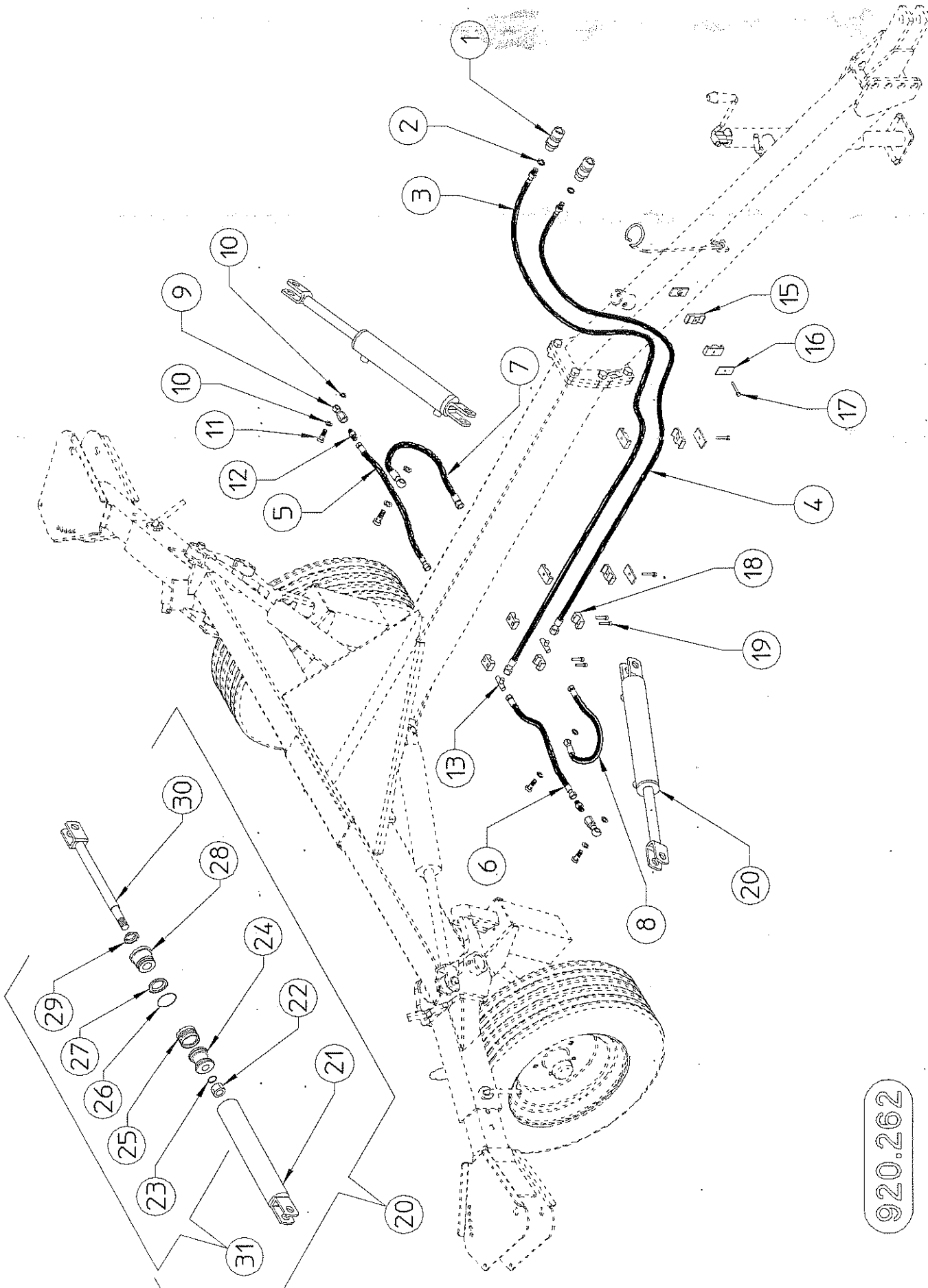

920.262

TABLE PART NO 920.262				
ITEM	Q.ty	PART NO	DESCRIPTION	NOTE
1	2	600.273	RAPID COUPLIG 1/2"	
2	2	600.269	COPPER WASHER 1/2"	
3	1	630.098	HOSE SAE100 R7 1/4" L4300 FD-MD	For QR/10-12
3	1	630.318	HOSE SAE100 R7 1/4" L5100 FD-MD	For QR/12
4	1	630.099	HOSE SAE100 R7 1/4" L4150 FD-MD	For QR/10-12
4	1	630.319	HOSE SAE100 R7 1/4" L4950 FD-MD	For QR/12
5	1	630.316	HOSE SAE100 R7 1/4" L425 FD-FD	
6	1	630.317	HOSE SAE100 R7 1/4" L545 FD-FD	
7	1	630.313	HOSE SAE100 R7 1/4" L475 FD-OC	
8	1	630.314	HOSE SAE100 R7 1/4" L420 FD-OC	
9	2	630.315	TURNING FITTING FD-OC	
10	8	600.039	COPPER WASHER 3/8"	
11	4	600.040	FITTING SCREW	
12	2	200.192	NIPPLE 3/8" - 3/8" 0,8	
13	2	600.823	FITTING M-M-M 1/4"	
14				
15	6	630.078	HOSE COLLAR	
16	3	610.802	PLATE	
17	3	610.803	SCREW M6X35 DIN 931	
18	4	610.787	HOSE COLLAR	
19	4	610.037	SCREW M6X25 TCEI	
20	2	230.302	CYLINDER	
21	2	230.385	CYLINDER BARREL	
22	1*	600.879	NUT	*For one cylinder
23	1*	600.983	GASKET	*For one cylinder
24	2	210.227	PISTON	
25	1*	600.984	GASKET	*For one cylinder
26	1*	600.982	GASKET	*For one cylinder
27	1*	610.031	GASKET	*For one cylinder
28	2	210.569	CYLINDER HEAD	
29	1*	600.645	GASKET	*For one cylinder
30	2	230.386	ROD	
31	1*	610.340	SET OF GASKET	*For one cylinder

PART NO 920.265 QR/8-10-12

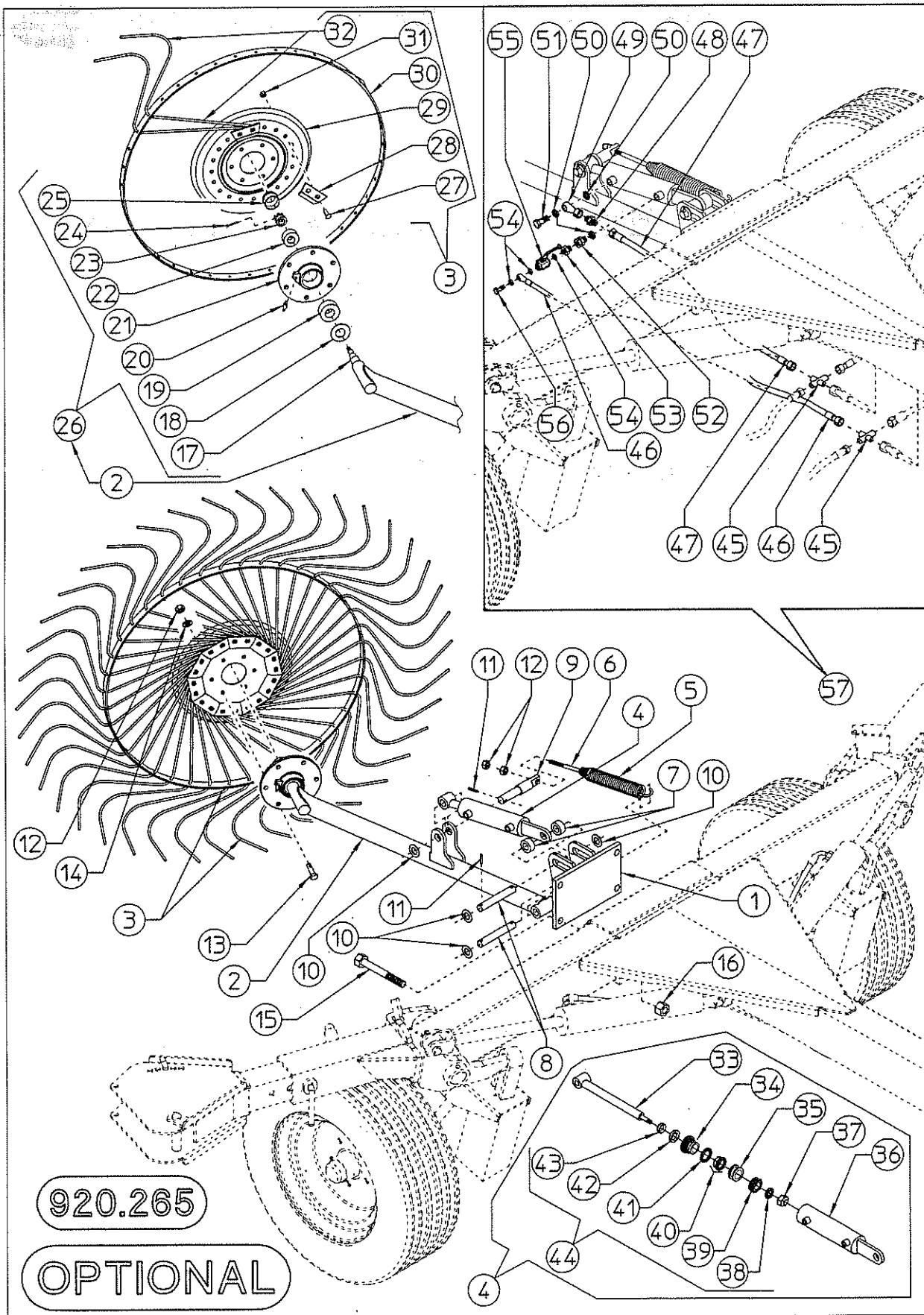

TABLE PART NO 920.265				
ITEM	Q.ty	PART NO	DESCRIPTION	NOTE
1	1	230.306	SUPPORT	
2	1	230.374	ARM	
3	1	200.802	WHEEL ASSY L.H. (TINE DIA 0,276" 7mm)	
4	1	230.375	CYLINDER	
5	1	230.376	SPRING	
6	1	210.173	TIE ROD	
7	2	230.377	SPACER	
8	2	230.378	PIN	
9	1	230.379	PIN	
10	5	600.632	WASHER ø21 DIN 125A	
11	5	600.538	SPING PIN ø6x35 DIN 1481	
12	8	600.010	NUT M10 DIN 934	
13	6	600.006	SCREW M10 x 25 DIN 933	
14	6	600.024	SPRING WASHER D 10,5 similar to	DIN 127B
15	4	600.219	SCREW M16x150 DIN 931	
16	4	600.080	NUT M16 DIN 980	
17	1	205.277	PIN	
18	1	600.011	DUST COVER	
19	1	600.012	BEARING 30205	
20	1	600.034	GREASE NIPPLE M8	
21	1	600.013	WHEEL HUB	
22	1	600.014	BEARING 30204	
23	1	600.015	SELF-LOCKING NUT M18x1,5	
24	1	600.301	SPLIT PIN ø3x30 DIN 94	
25	1	600.016	SAFETY CAP	
26	1	205.041	HUB ASSY	
27	20	600.005	SCREW M10x25 DIN 603	
28	10	200.012	TINE CLAMP	
29	1	200.010	FLANGE	
30	1	200.840	RIM	
31	20	600.029	NUT M10 DIN 980	
32	40	200.841	TINE DIA 0,276" (7mm)	
33	1	230.400	ROD ø20	
34	1	230.398	HEAD ø40/20	
35	1	230.397	PISTON ø40	
36	1	230.399	CYLINDER BARREL ø40/50	
37	1	600.121	NUT M18x1,5 DIN 985	
38	1	630.322	GASKET OR ø12,34x2,62	
39	1	610.028	GASKET DBM 157118	
40	1	630.321	GASKET OR ø36,14x2,62 + BK	
41	1	630.323	GASKET OR ø39,34x2,62	
42	1	630.324	GASKET ø20/28x5,8	
43	1	610.025	GASKET WRM 078110	
44	1	630.325	SET OF GASKET	
45	2	620.978	FITTING 1/4"	
46	1	620.980	HOSE SAE 100R7x1/4"	
47	1	620.979	HOSE SAE 100R7x1/4"	
48	1	200.192	NIPPLE 3/8"-3/8" WITH ORIFICE 0,8	
49	1	630.315	FITTING 3/8"	
50	3	600.039	COPPER WASHER 3/8"	
51	1	600.040	FITTING 3/8"	
52	1	600.271	FITTING 3/8" MALE-3/8" FEMALE	
53	1	600.883	NIPPLE 1/4"-3/8"	
54	3	600.819	COPPER WASHER 1/4"	
55	1	620.492	VALVE 1/4" 170 bar	
56	1	600.820	FITTING 1/4"	
57	1	230.344	HYDRAULIC KIT	
*	1	230.371	COMPLETE KIT	OPTIONAL



AGRICULTURAL MACHINERY
sitrex® SpA

Zona Industriale-Viale Grecia, 8
06018 TRESTINA-(Perugia)-ITALY
Tel. +39.075.8540021-Telefax +39.075.8540523
e-mail: sitrex@sitrex.it www.sitrex.com

