

AGRICULTURAL MACHINERY

sitrex®
Spa

**ASSEMBLY
USE AND MAINTENANCE
SPARE PARTS LIST**

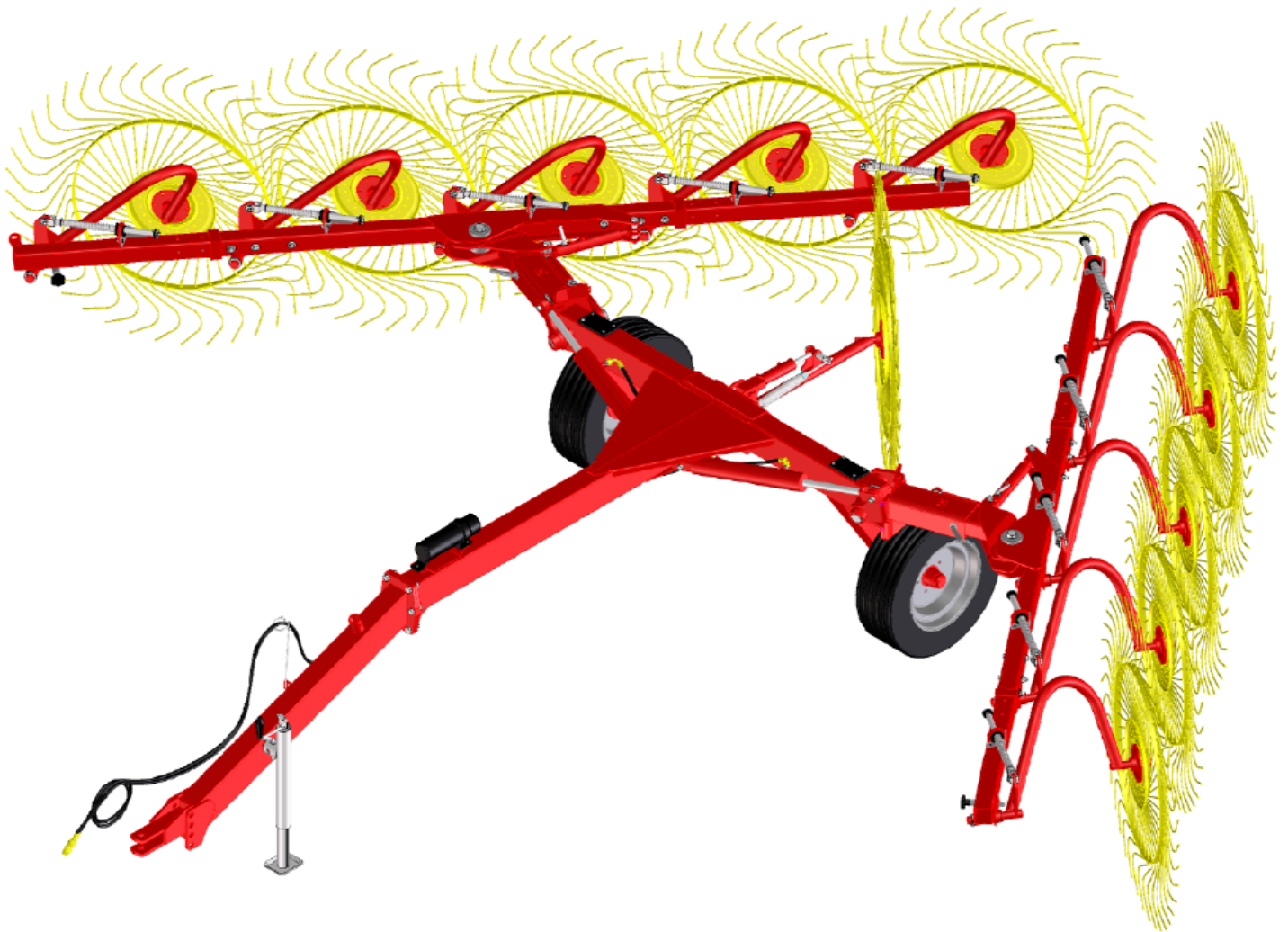

QR / 8-10-12

Spare parts should be ordered with serial number

FROM 01/2011

Warranty

On delivery, check that the machine has not been damaged during transport and that all the attachments are present. Claims must be made in writing to the agent within 8 days of receipt.

The manufacturer warrants new machinery at the time of delivery to the original purchaser to be free from defects in material and workmanship if properly set up and operated in accordance with this Operator's Manual.

The manufacturer undertakes to repair or replace free of charge any defective part which should be returned by the purchaser (freight prepaid) and found to be defective by inspection authorized by the manufacturer during the warranty period.

This warranty will be valid for 12 (twelve) months from the delivery of goods to the original purchaser .

In case the customer is not in a position to return the defective part to the manufacturer , the manufacturer cannot be held responsible for any cost due for repair or replacement of any part of the machine , he will only supply the part(s) required for the repair and/or replacement.

The warranty is null and void when it is evident that the machine has been improperly used or however repaired without authorization.

The manufacturer undertakes no responsibility for any obligation or agreement reached by any employers, agents or dealers, which are not in compliance with the above warranty . The manufacturer cannot be held responsible for the consequent damages. This warranty substitutes any other warranty , express or implied , and any other manufacturer's obligation.

NOTE: ALL WARRANTY WORK OR REPAIRS MUST BE APPROVED BY THE MANUFACTURER BEFORE WORK BEGIN. ANY WORK OR REPAIRS MADE BEFORE APPROVAL MAY NOT BE COVERED UNDER WARRANTY. PLEASE NOTIFY YOUR SALES & SERVICE DEPARTMENT OF THIS POLICY.

TABLE OF CONTENT:

- 1) **GENERAL INSTRUCTIONS**
- 2) **GUIDE TO THE SIGNS AND SYMBOLS**
- 3) **PRODUCT IDENTIFICATION**
- 4) **DELIVERY AND ASSEMBLY INSTRUCTIONS**
- 5) **ADJUSTMENTS FOR MACHINE USE**
- 6) **TRANSPORT BY ROAD**
- 7) **GENERAL MAINTENANCE INSTRUCTIONS**
- 8) **SPARE PARTS LIST**

1) General instructions for the operation and maintenance

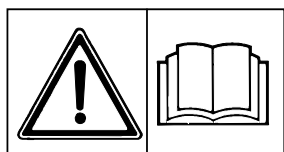

Read all the directions carefully before using the machine. When in doubt, seek advice from the manufacturers. The manufacturing company declines all responsibility for non-compliance with the following safety and accident-prevention instructions.

- 1-** Pay attention to the danger signs and symbols in this manual and on the machine.
- 2-** Do not touch moving parts.
- 3-** All work on the machine (including adjustments) must always be carried out with the tractor immobilized and the engine switched off.
- 4-** It is strictly prohibited to carry persons or objects on the machine and/or on the tractor.
- 5-** Driving the tractor with the machine connected is absolutely forbidden to persons lacking suitable experience, or who are in poor health, or who do not have a suitable driving license.
- 6-** All accident-prevention measures recommended in this manual should be scrupulously observed.
- 7-** When a machine is attached to the tractor, always evaluate the suitability of the tractor for the purpose, in order to work safely. Keep in mind that when a machine is attached to the tractor – even if it is a towed type – it alters the tractor's stability, and therefore all the necessary precautions must be taken (ballast, tire pressure, etc.).
- 8-** Before operating the tractor and machine, check that all transport and operational safety devices are complete and working.
- 9-** When driving on public roads, you should comply with the Highway Code regulations for the country concerned.
- 10-** Before starting work, familiarize yourself with the control devices and how they work.
- 11-** Wear suitable clothes. Do not wear clothing which is loose or which could become entangled in rotating or moving parts.
- 12-** Never leave the driving seat when the tractor is running.
- 13-** It is extremely important to appreciate that road holding, steering and braking may be significantly affected with the machine attached.
- 14-** Before connecting unit, stop the engine, apply the parking brake and remove the ignition key from the instrument panel.
- 15-** Spare parts must meet the requirements as defined by the manufacturer. Use only original spare parts.
- 16-** Safety decals must always be clearly visible. They must be kept clean and replaced if they become too illegible (they can be ordered from the agent if necessary).

2) Guide to the signs and symbols used on the machine

IMPORTANT

These signs and symbols give information to the operator on how to make the best use of the machine so as to prolong life, avoid damage, optimise work and, above all, to avoid injury to the operator and anyone within range of the machine. Note well: most of the symbols that you will find below are located on the machine, but some are only in this manual and indicate how to act or what must be done during assembly, when maintenance or repairs are being done, etc..

WARNING SIGNS

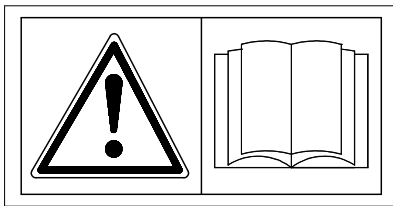

1) Before beginning operations, read the instruction manual carefully.

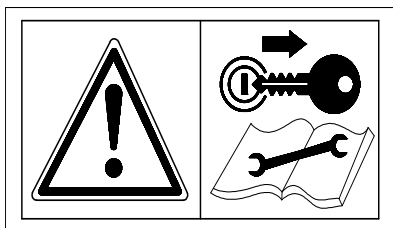

2) Before doing any maintenance or repair work, stop the machine at a suitable spot. Turn off the tractor motor, apply the brake, remove the key from the ignition and consult this manual.

DANGER SIGNS

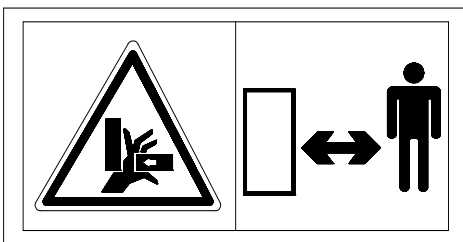

3) Warns against potential serious danger of hands being crushed. Keep away.

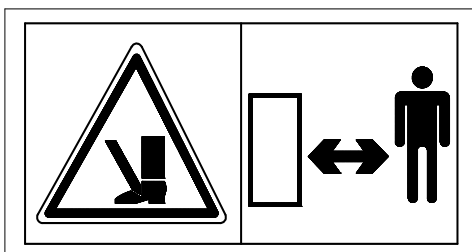

4) Warns against potential serious danger of injury to the feet. Keep away.



5) Use paper or cardboard to check for and/or clean any leaks from cylinders and oleo dynamic components in general. Never touch with bare hands, as it is harmful to the skin.



6) Warns against the potential and serious dangers to the driver and/or other persons who are near or on the machine or tractor when the tractor is used improperly and/or incautiously.

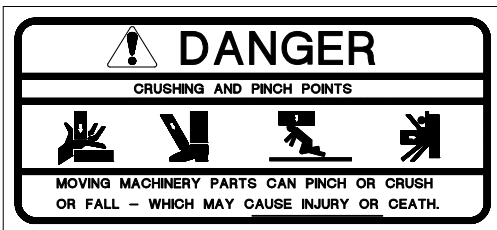

7) Summarizes all the potential and serious dangers that one risks when working improperly on the machine during assembly, use, maintenance or repair.

SYMBOLS FOR INDICATIONS AND/OR RULES

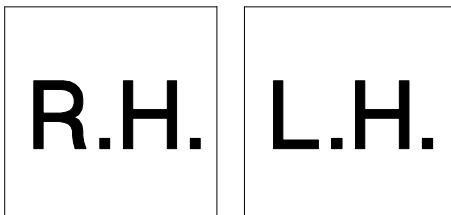

8) Indicates the components to be assembled on the right or left side of the machine. The R and L sides of the machine are usually determined by standing behind the machine and looking forward.

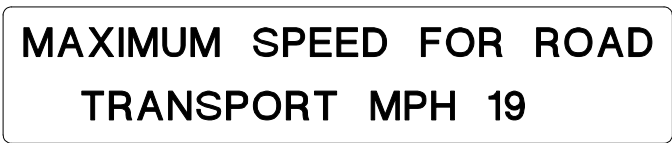

9) Indicates the maximum speed during transport (19 MPH - 30 Km/h)

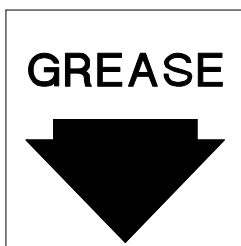

10) Indicates a greasing point.

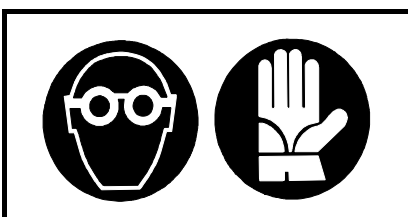

13) Recommends working with suitable clothing and/or protection during assembly, use, maintenance and repair.

Examples of general measurements for identifying the assembly accessories based on type.

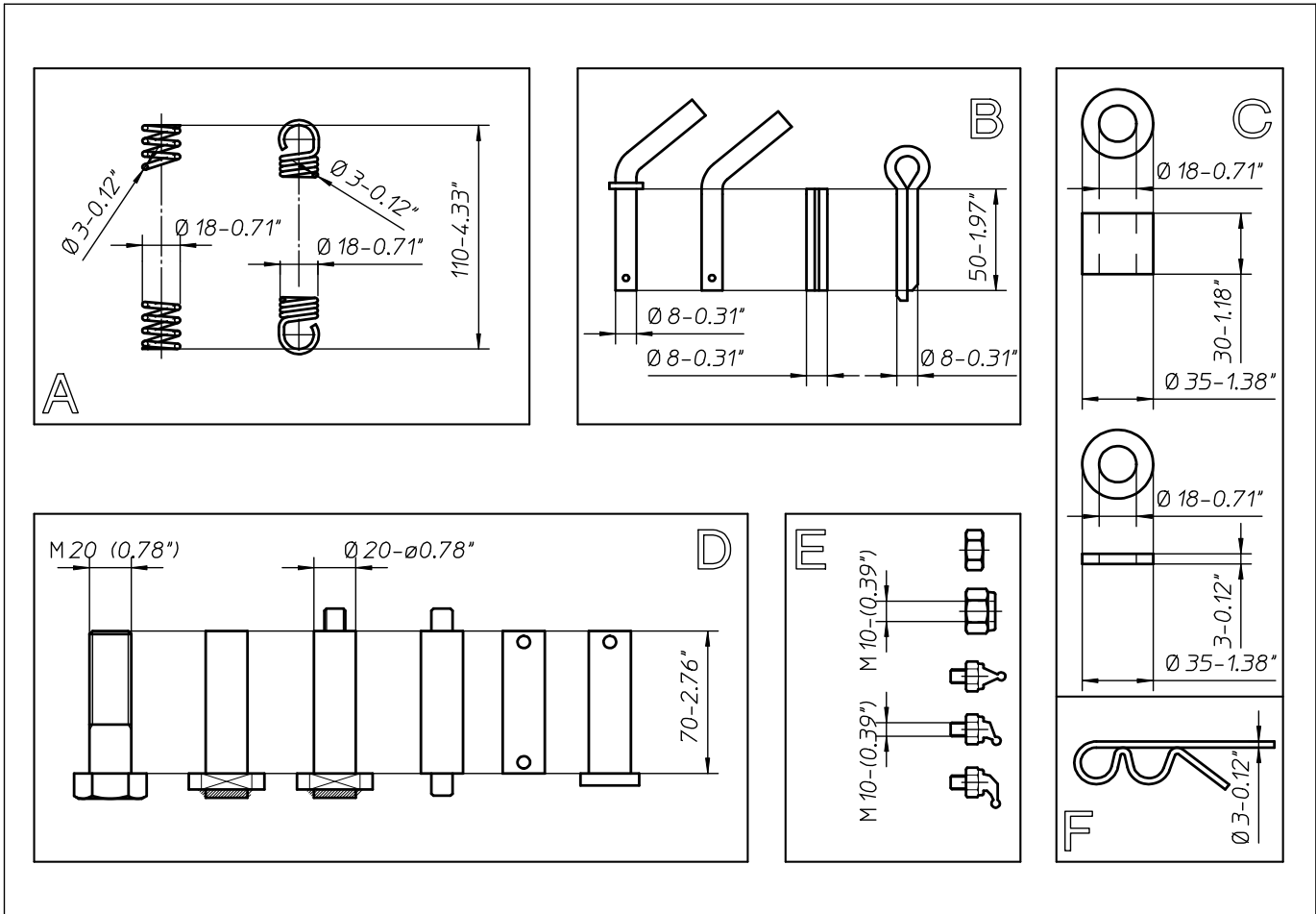

When tightening the bolts refer to the tightening torque table (the class of the material is generally stamped on the head of the bolts).

MINIMUM HARDWARE TIGHTENING TORQUES

IN NEWTON-METERS (FOOT POUNDS) FOR NORMAL ASSEMBLY APPLICATIONS

METRIC NON-FLANGED HARDWARE AND LOCKNUTS

NOMINAL SIZE	CLASS 5.8		CLASS 8.8		CLASS 10.9		LOCKNUT CL.8 W/CL.8.8 BOLT
	UNPLATED	PLATED W/ZnCr	UNPLATED	PLATED W/ZnCr	UNPLATED	PLATED W/ZnCr	
M4	1.7 (15)*	2.2 (19)*	2.6 (23)*	3.4 (30)*	3.7 (33)*	4.8 (42)*	2.3 (20)*
M6	5.8 (51)*	7.6 (67)*	8.9 (79)*	12 (102)*	13 (115)*	17 (150)*	7.8 (69)*
M8	14 (124)*	18 (159)*	22 (195)*	28 (248)*	31 (274)*	40 (354)*	19 (169)*
M10	28 (21)	36 (27)	43 (32)	56 (41)	61 (45)	79 (58)	38 (28)
M12	49 (36)	63 (46)	75 (55)	97 (72)	107 (79)	138 (102)	66 (49)
M16	121 (89)	158 (117)	186 (137)	240 (177)	266 (196)	344 (254)	164 (121)
M20	237 (175)	307 (226)	375 (277)	485 (358)	519 (383)	671 (495)	330 (243)
M24	411 (303)	531 (392)	648 (478)	839 (619)	897 (662)	1160 (855)	572 (422)

NOTE: Torque values shown with * are inch pounds.

3) Product identification

Please write below the type and serial number of the machine. This information is to be provided to the dealer for all spare parts orders.

 AGRICULTURAL MACHINERY sitrex [®] <small>06018 TRESTINA-PERUGIA-ITALY</small> <small>TEL.075-8540021 FAX 075-8540523</small>	
SERIE	N°
<i>MADE IN ITALY</i>	

Optional equipment
 Center wheel kit
 Safety chain

Machine Specifications

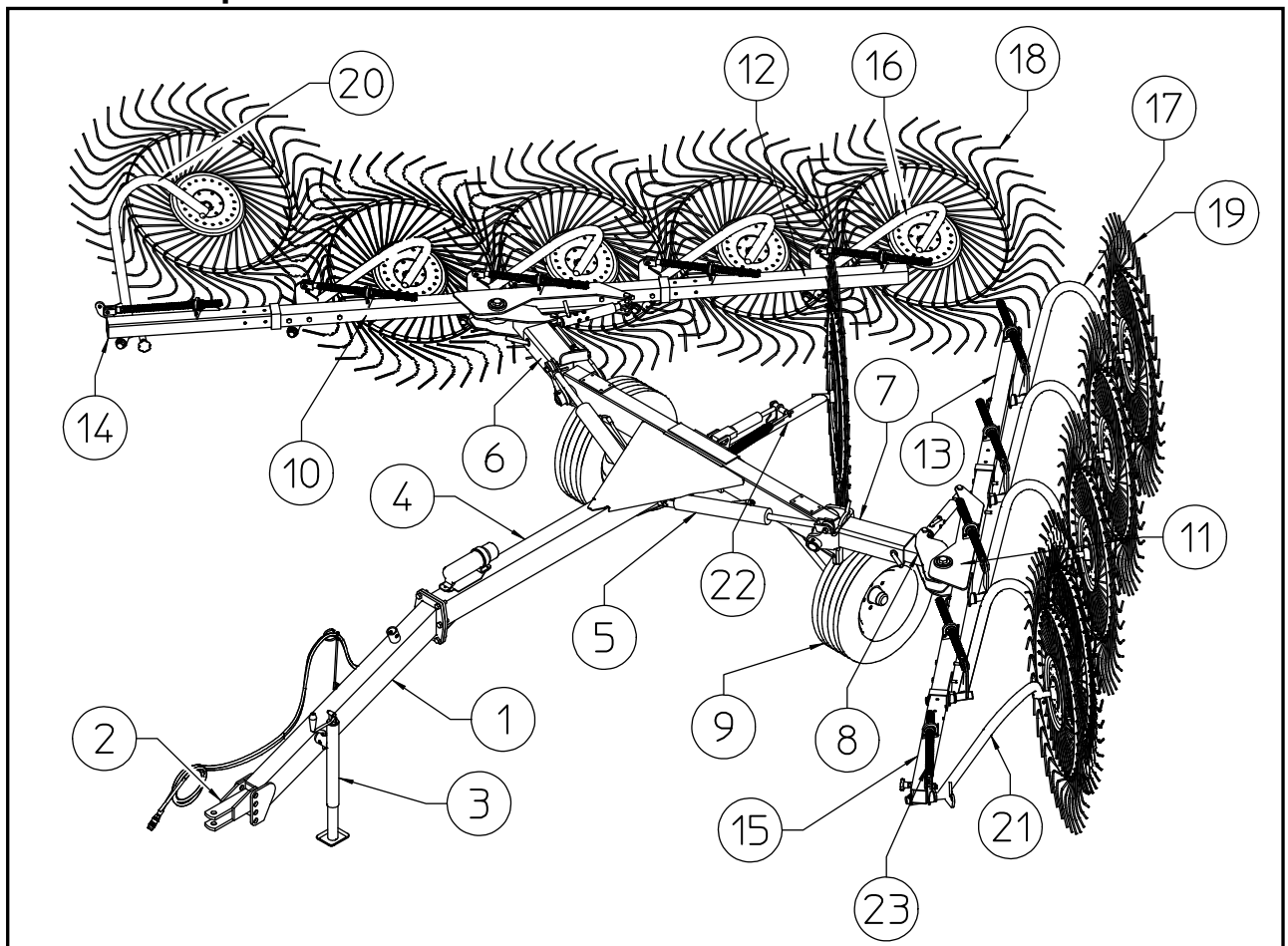

- | | |
|-------------------|---------------------------------|
| 1) DRAWBAR | 12) MAIN PIPE R.H. |
| 2) BRACKET | 13) MAIN PIPE L.H. |
| 3) PARKING STAND | 14) EXTENSION PIPE R.H. |
| 4) DRAWBAR | 15) EXTENSION PIPE L.H. |
| 5) CYLINDERS | 16) WHEEL ARM R.H. |
| 6) ARM R.H. | 17) WHEEL ARM L.H. |
| 7) ARM L.H. | 18) WHEEL ASSY R.H. |
| 8) TELESCOPIC ARM | 19) WHEEL ASSY L.H. |
| 9) TIRE ASSY | 20) SPECIAL ARM R.H. |
| 10) PIPE R.H. | 21) SPECIAL ARM L.H. |
| 11) PIPE L.H. | 22) CENTER WHEEL KIT (optional) |

TECHNICAL SPECIFICATIONS

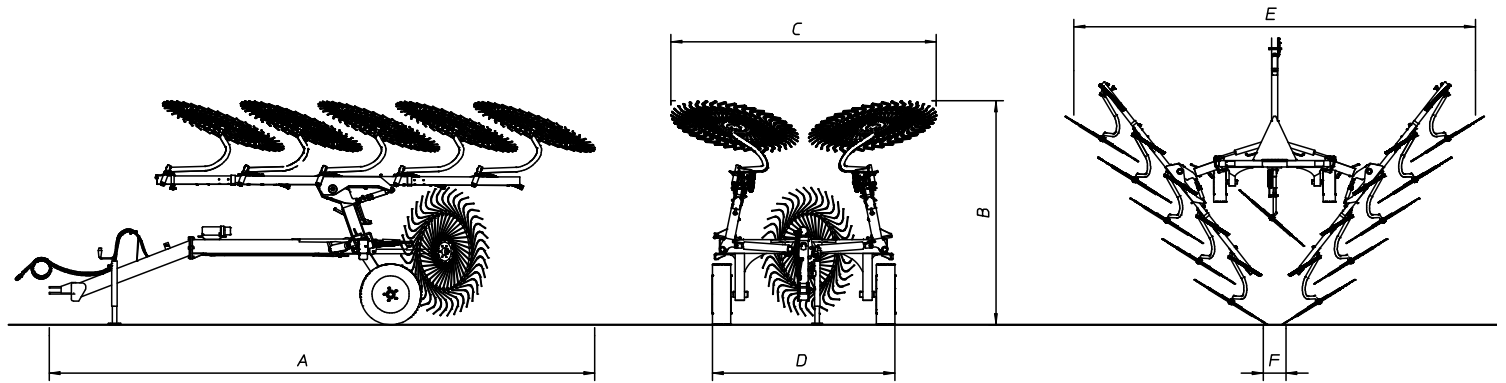

MODEL	QR 8	QR 10	QR 12
Number of Finger Wheels	8	10	12
Overall length (A) (1)	19' (5,8 m)	19' (5,8 m)	22' (6,7 m)
Minimum Transport Height (B)	7' 9"(2,4 m)	7' 9"(2,4 m)	8' 2"(2,5 m)
Transport Width (C)	8' 5" (2,6 m)	8' 5" (2,6 m)	8' 5" (2,6 m)
Width (D)	6' 6" (1,98 m)	6' 6" (1,98 m)	6' 6" (1,98 m)
Minimum Working Width (E) (1)	16' 4" (5 m)	19' (5,8 m)	21' 8" (6,6 m)
Maximum Working Width (1)	18' (5,5 m)	21' (6,4 m)	24' 6" (7,5 m)
Minimum Windrow Width (F) (1)	3' (0,9 m)	3' (0,9 m)	3' (0,9 m)
Maximum Windrow Width (1)	6' 7" (2 m)	6' 7" (2 m)	6' 7" (2 m)
Weight	1675 Lbs-760 Kg	1875 Lbs-850 Kg	2115 Lbs-960 Kg
Tires	205-75/15	205-75/15	205-75/15
Tractor Requirements HP	30 (22,3 KW)	30 (22,3 KW)	50 (36,7 KW)

(1) Depending on crop conditions

4) Delivery and assembly

Delivery and unpacking.

The machine is delivered partially assembled in no. 1 (a) box containing the stars and no. 3 (three) boxes. The boxes "A" and "B" are all the various mounting accessories (pins, screws, fittings, etc..) In the smaller box is not marked by letters to apply the triangle reflectors on the machine. All components are inspected before shipment from the manufacturer. Upon receipt of the machine, ensure that the case is intact and that the content has not been damaged during transport. If you detect damage and / or anomalies immediately report the matter to your vendor. Note: The packaging is made from wood, plastic films, cardboard and steel, must be disposed of according to applicable laws in your locality.

To unpack the boxes received by using suitable lifting is to lift the weight given to the banks to bring stability to the pallets because of their size and shape.

Each machine is allocated in a box containing the rake wheels.

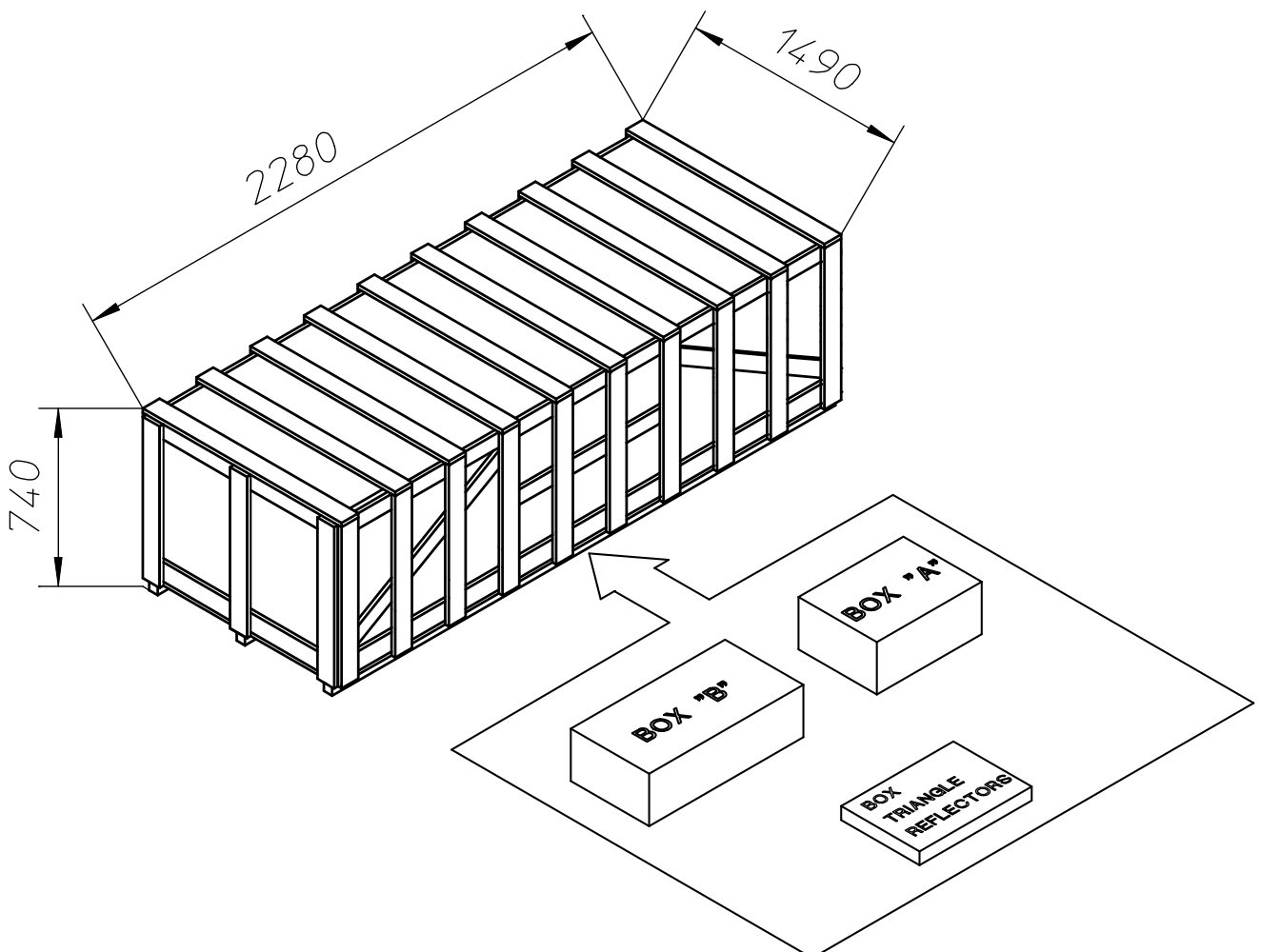

Assembly instructions

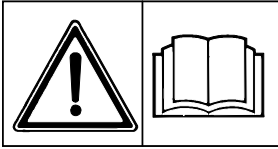

ATTENTION

Assembly must be done carefully and accurately, for the safety of the person(s) doing the assembling and to ensure proper machine operation.

Assembly should be done on a flat, solid surface, using the proper tools and wearing suitable clothing, making sure that all people not involved in the assembly be kept at a safe distance. Assemblers must provide suitable lifting mechanisms and supports for stabilizing the partially assembled units, so as to prevent them from falling and causing damage or injury. The steps for assembly are illustrated in following. Depending on the experience of the assemblers and the tools available, it is not necessary that the instructions be followed in the exact order given here, but the safety precautions described above must always be followed carefully and scrupulously.

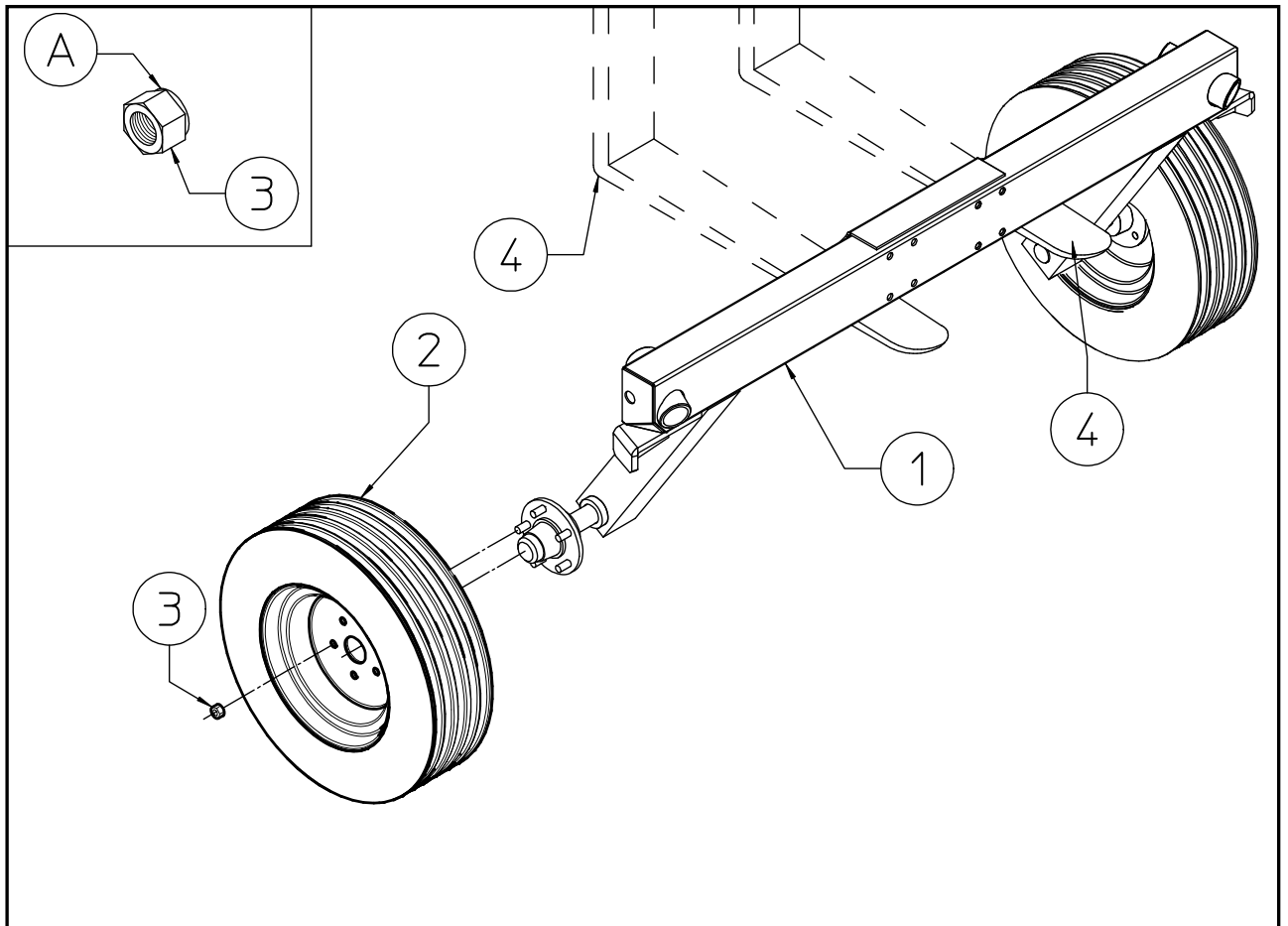

Mount wheels (2) to hubs on frame (1) using special nut (3). The spherical side “A” off the nut (3) must be always turned towards the wheel rim flange. The forks (4) of a forklift may also be used to support the assembly.

Item 3 : 10 special nuts M16 (5/8”)

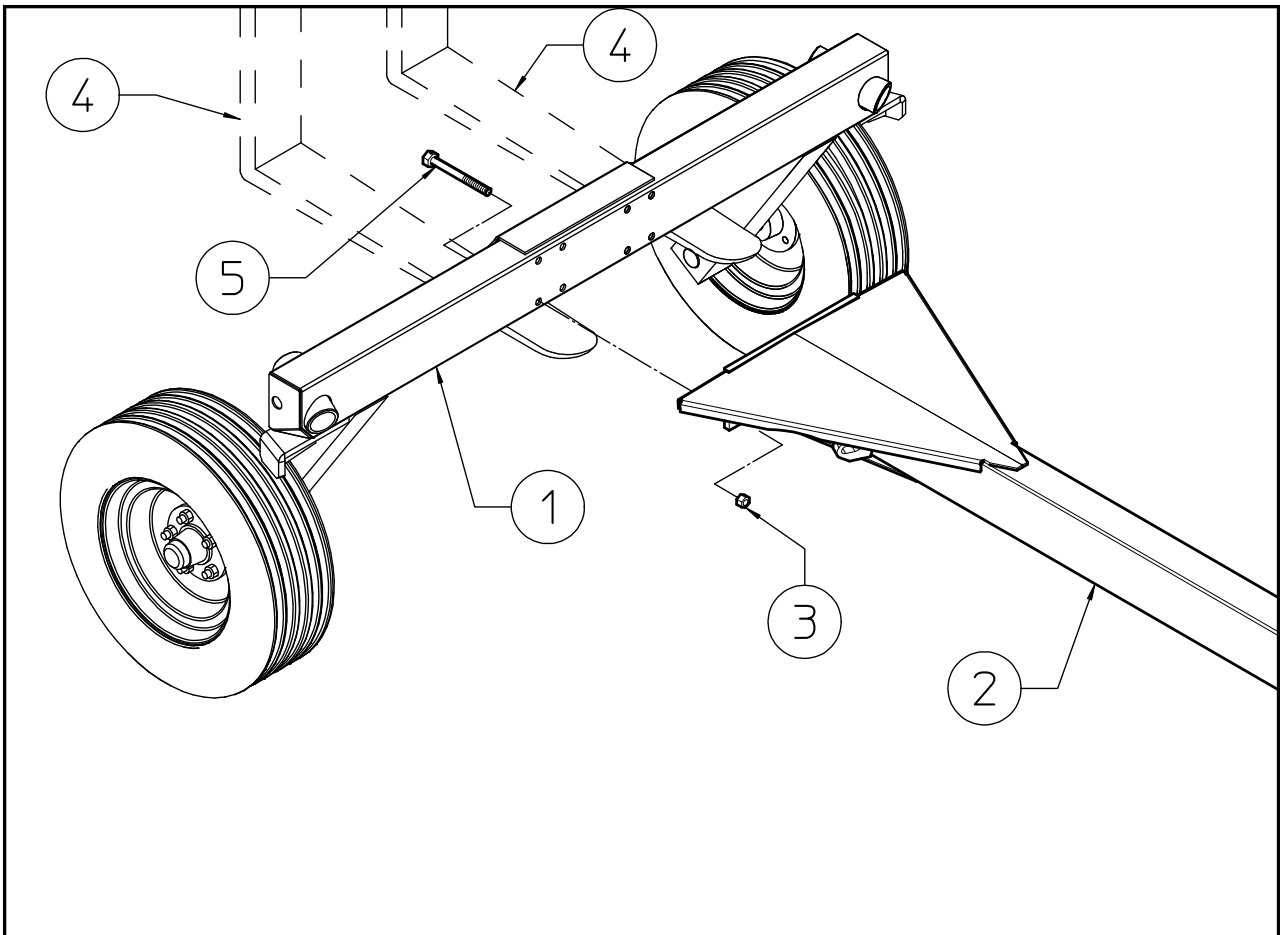

Attach the drawbar (2) to the frame (1) and fastening it with screws (5) and nuts (3).

Item (5) : 8 screws M16x140 (5/8"x 5 1/2")

Item (3) : 8 nuts M16 (5/8")

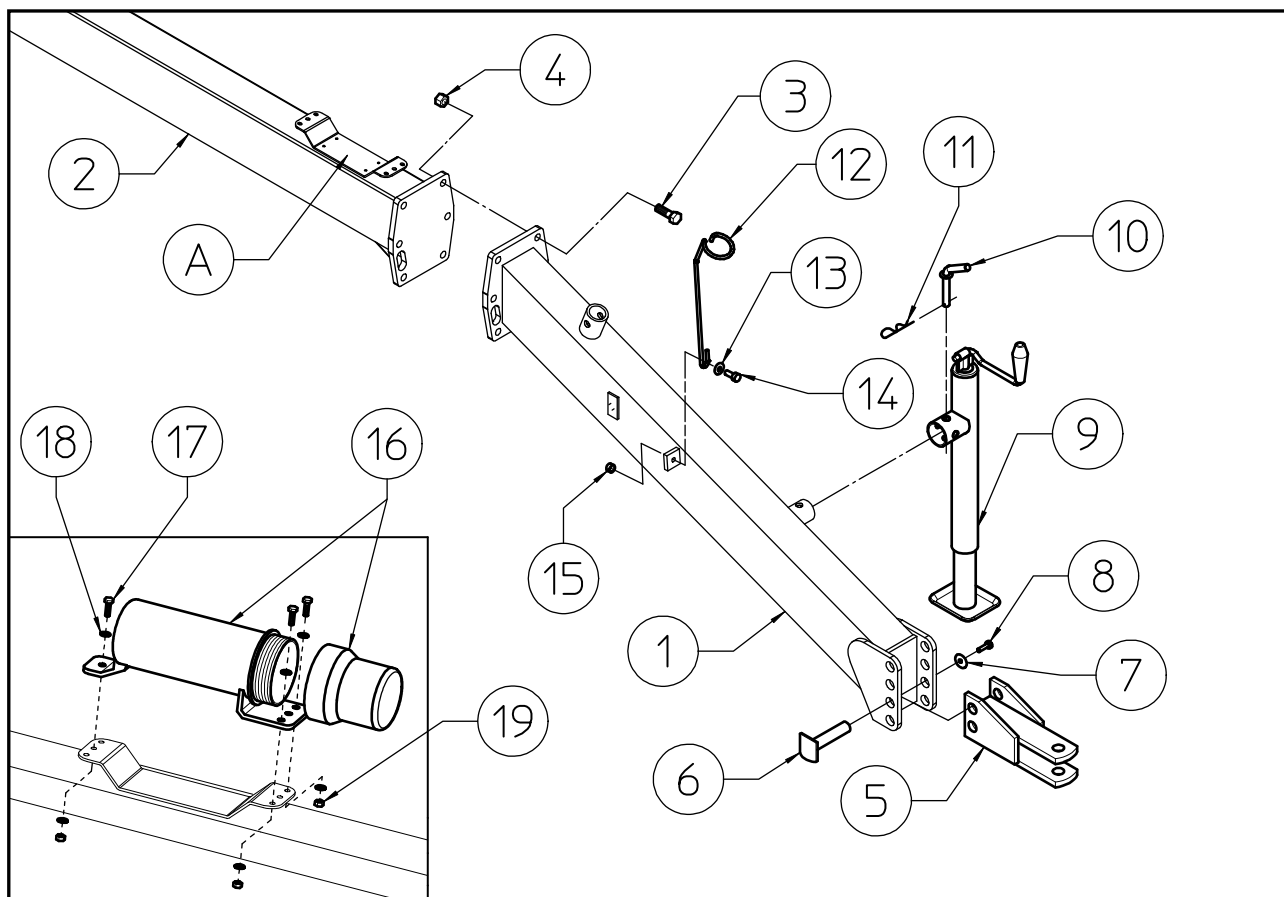

Attach the drawbar (1) to the drawbar (2) and fastening it with screws (3) and nuts (4). Attach the tractor hitch (5) to the drawbar (1) using the two pins (6), fastening with the screws (8) and washers (7).

To choose which should be used see ADJUSTMENTS FOR MACHINE USE section.

Attach parking stand (9) to drawbar (1), fastening it with pin (10) and clip (11).

Assemble the support hose (12) with the screw (14), washer (13) and nut (15). Attach the manual canister (16) to the drawbar at point (A) using screws (17), washers (18) and nut (19). Note: all manuals and other documents regarding the machine must be placed in the manual canister (16) so that they may be consulted at any time.

Item (3): 6 screw M16x50 (5/8"x 2")

Item (4): 6 nuts M16 (5/8")

Item (6): 2 pins $\varnothing 25 \times 124$ (1"x5")

Item (7): 2 washers $\varnothing 12-36 \times 2.5$ ($\varnothing 15/32$ "-1 27/64"x 3/32")

Item (8): 2 screws M12x20 (15/32"x13/16")

Item (10): 1 pin $\varnothing 15 \times 78$ ($\varnothing 19/32$ "x 3 1/8")

Item (13): 1 washer $\varnothing 12$ ($\varnothing 1/2$ "

Item (14): 1 screw M12x35 (15/32"x 1 5/8")

Item (15): 1 nut M12 (15/32")

Item (17): 3 screws M6x20 (0.24"x0.79")

Item (18): 6 washers $\varnothing 6.6-18 \times 2$ ($\varnothing 0.26$ "- 0.71"x0.08")

Item (19): 3 nut M6 (0.24")

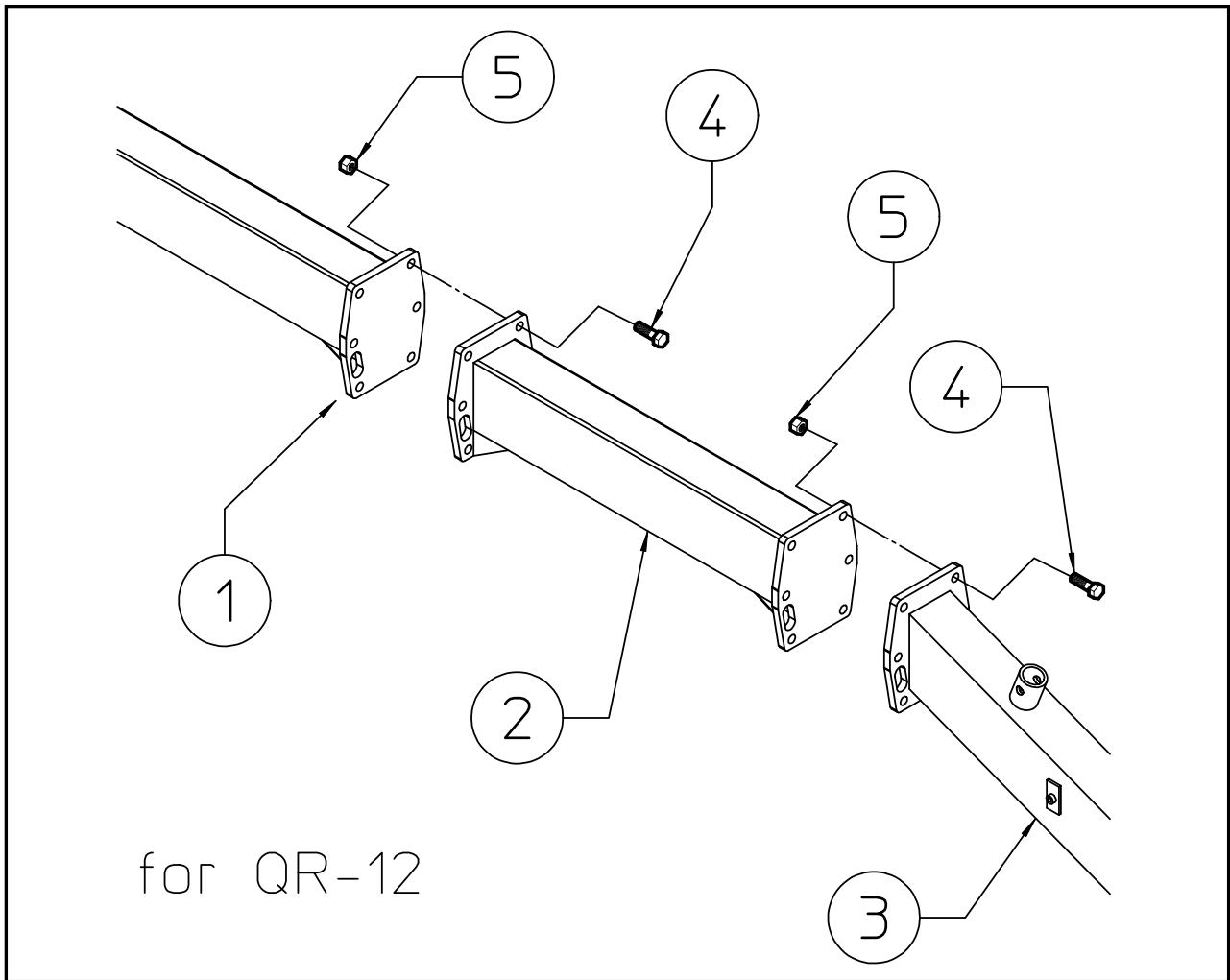

FOR QR/12 ONLY.

Insert and attach the drawbar extension (2) and fastening it with screws (4) and nuts (5).

Item (4): 6+6 screws M16x50 (5/8" x 2")

Item (5): 6+6 nuts M16 (5/8")

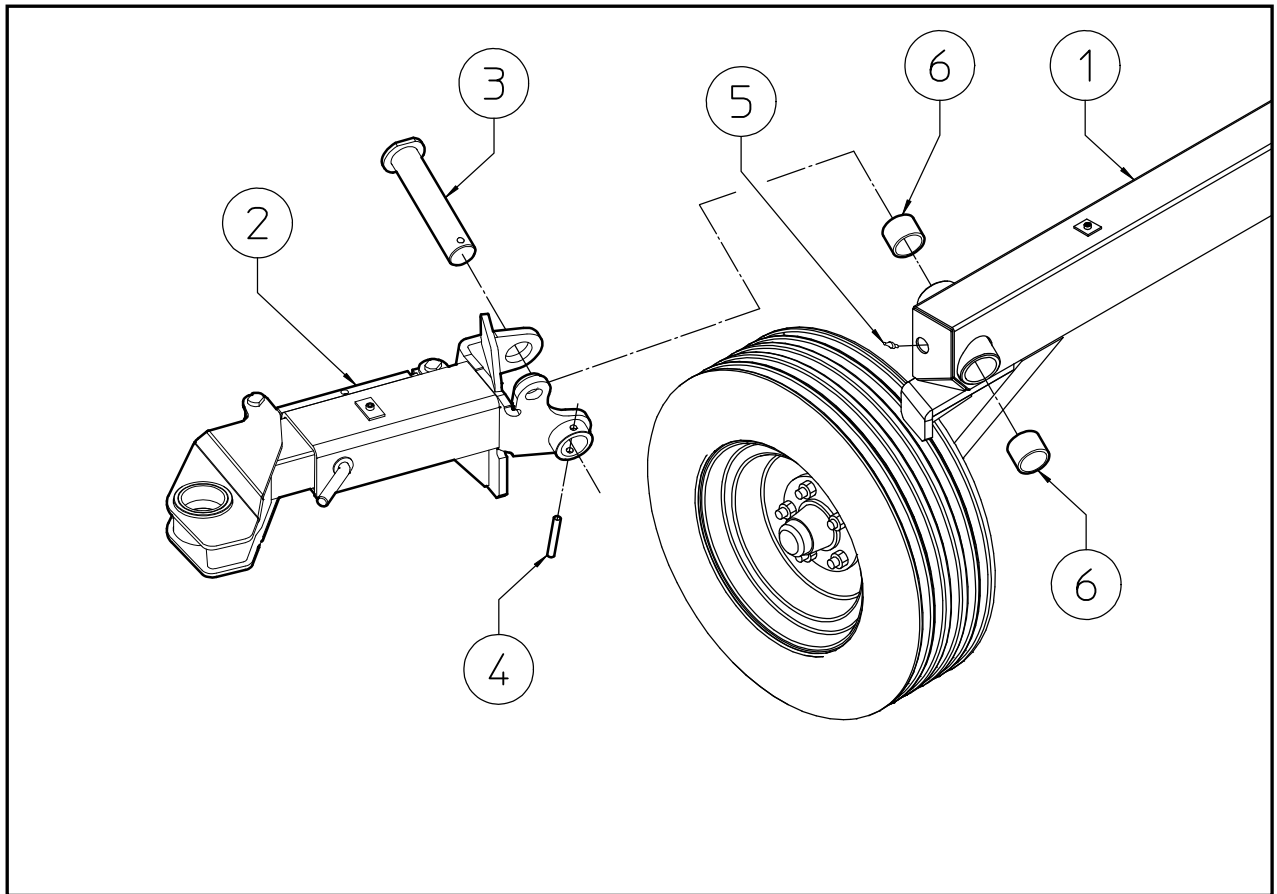

Fit bushing (6) on proper seats of frame (1).
 Fit in proper seats grease nipple (5).
 Attach the arm (2) (R.H.-L.H.) to the frame (1) using pins (3).
 Fasten pins (3) with spring pins (4).

Item (3): 2 pins $\varnothing 50 \times 243$ ($\varnothing 2 \times 9 \frac{1}{2}$ ")
 Item (4): 2 spring pins $\varnothing 12 \times 70$ ($\varnothing 1/2$ " $\times 2 \frac{3}{4}$ ")
 Item (5): 2 grease nipple M8
 Item (6): 4 bushings $\varnothing 50-60 \times 50$ (2 " - $2 \frac{3}{8}$ " $\times 2$ ")

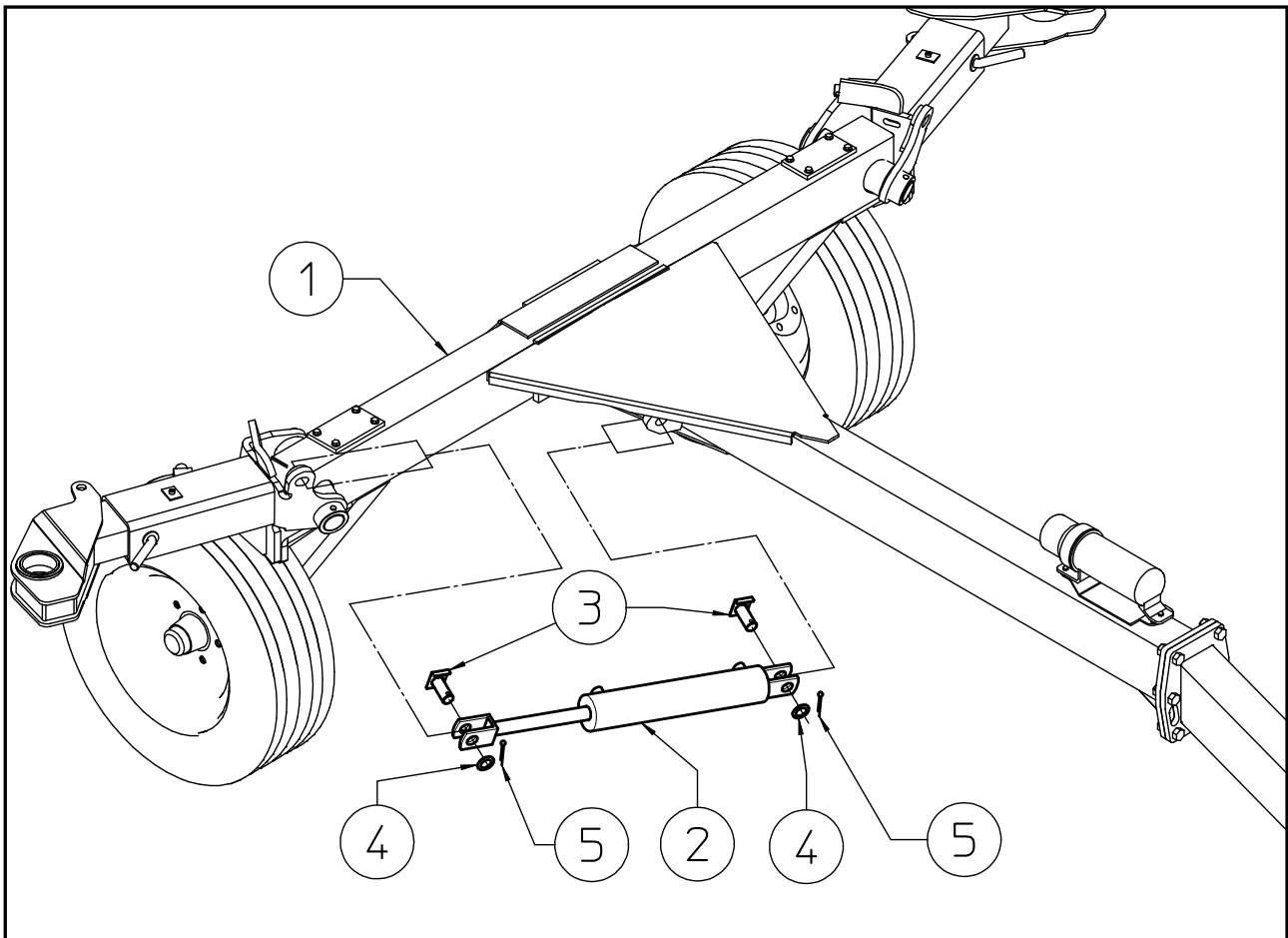

Attach the cylinders (2) to the lugs using pins (3) and split pins(5). Assemble the cylinders with distance washers (4) as shown in the diagram.

Item (3): 4 pins $\varnothing 25 \times 58$ ($\varnothing 1 \times 2 \frac{5}{16}$ ")

Item (4): 4 washers $\varnothing 25$ ($\varnothing 1$ ")

Item (5): 4 split pins $\varnothing 6 \times 35$ ($\varnothing \frac{1}{4}$ " \times $1 \frac{1}{2}$ ")

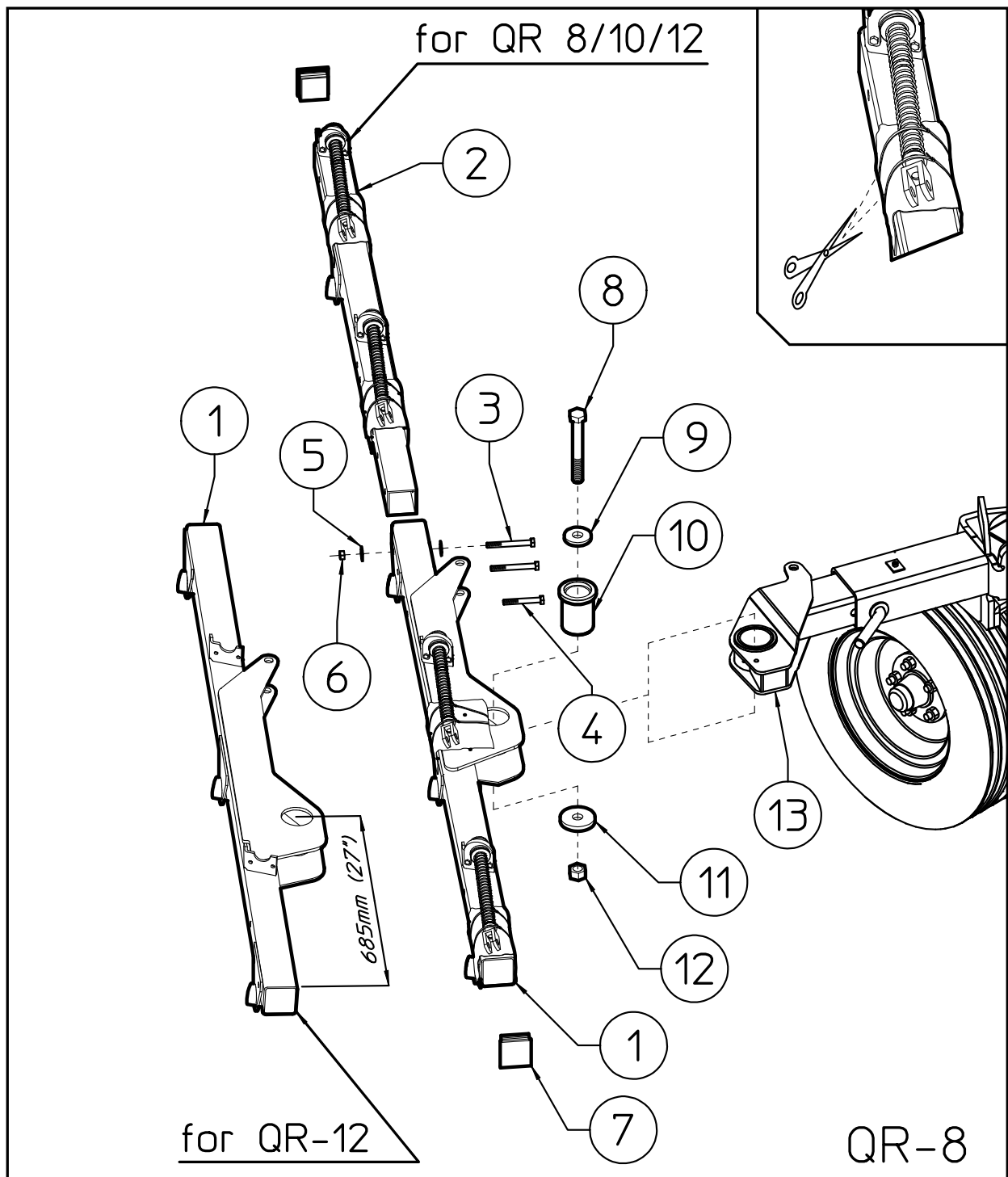

Attach the main pipe (1) to arm (13) using pin (10) washers (9) (11), screw (8) and nut (12). Insert pipe (2) to the main pipe (1), fastening it with the screws (3) and (4) washers (5) and nut (6). Insert plug (7) to main pipe (1) (2).

- | | |
|--|---|
| Item (3): 2+2 screws M12x110 (15/32"x4,3") | Item (8): 2 screws M24x150 |
| Item (4): 1+1 screws M12x100 (15/32"x4") | Item (9): 2 washers \varnothing 25-64x10 |
| Item (5): 6+6 washers \varnothing 13 (\varnothing 1/2") | Item (10): 2 pin \varnothing 75x107 |
| Item (6): 3+3 nuts M12 (15/32") | Item (11): 2 washers \varnothing 25/90x10 |
| Item (7): 4 plug | Item (12): 2 nuts M24 |

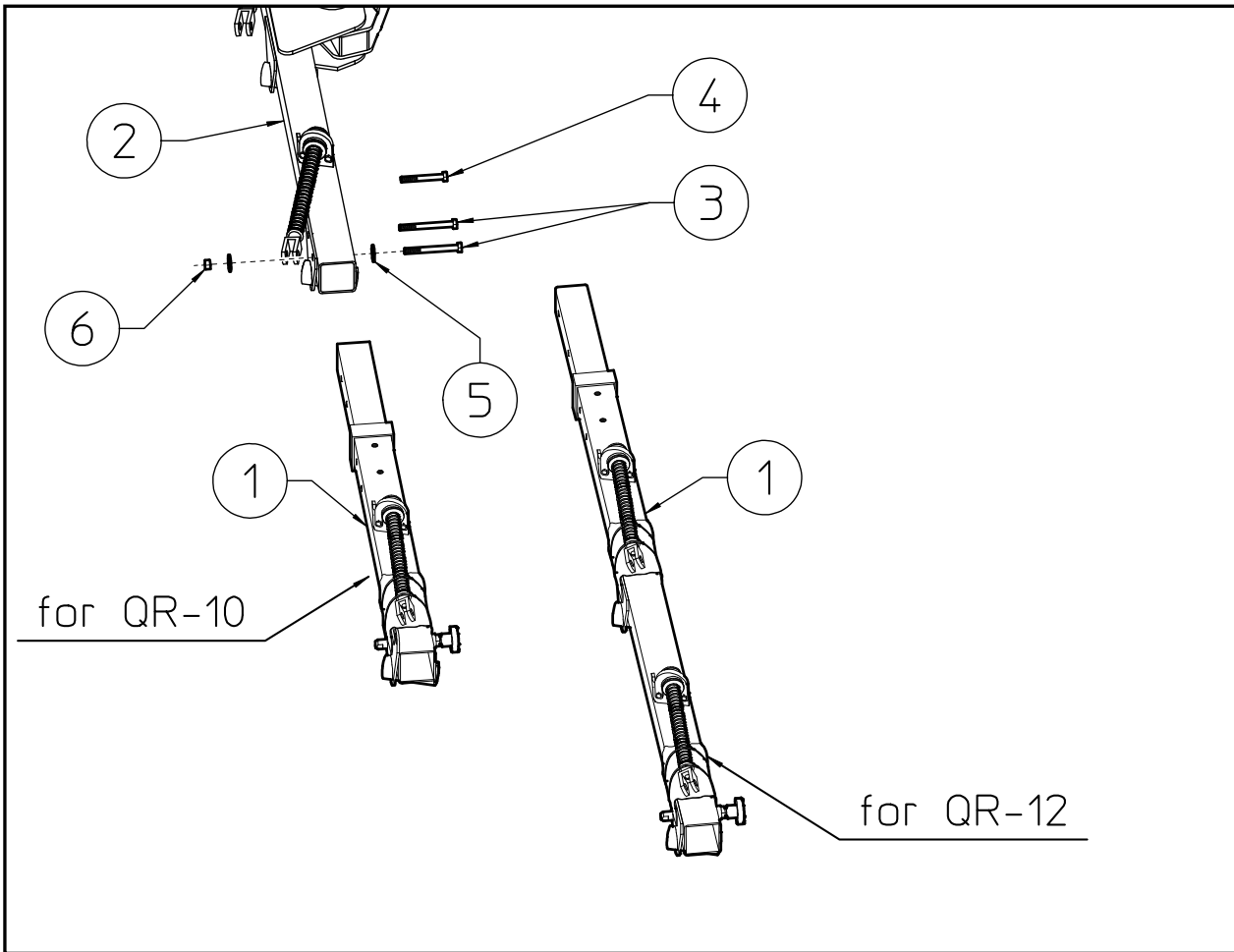

Insert pipe (1) to the main pipe (2), fastening it with the screw (3) and (4) washers (5) and nuts (6). Insert plug to main pipe (1).

Item (3): 3+3 screw M12x100 (15/32"x4)

Item (4): 6+6 washers $\varnothing 13$ ($\varnothing 1/2$ ")

Item (5): 3+3 nuts M12 (15/32")

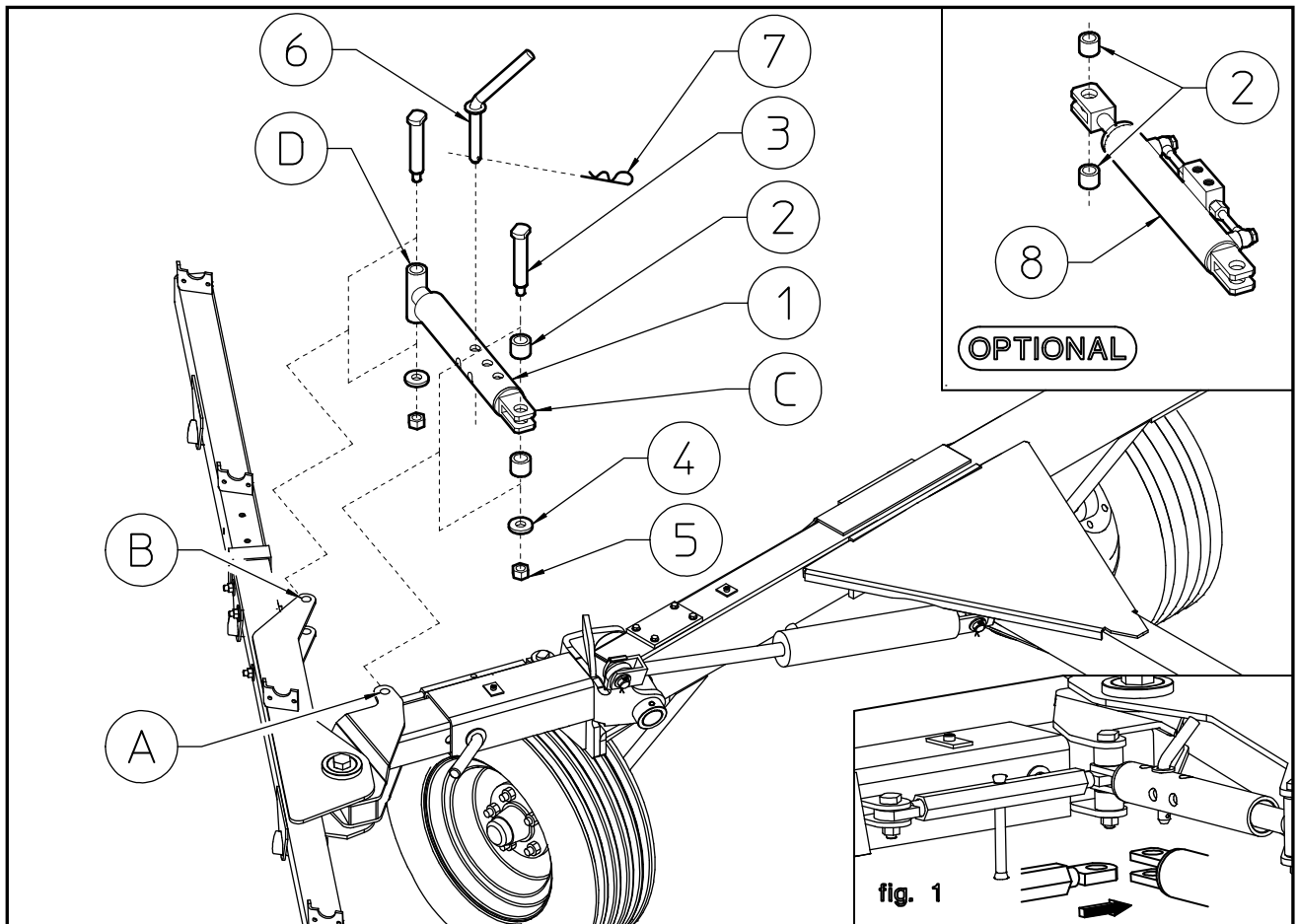

Attach the manual angle tie-rod (1) at the two points (A) and (B), the rear end (C) at point (A) and the front end (D) at point (B), using the pins (3), bushes (2), washers (4) and nuts (5).

Insert pin (6) into the holes to choose the desired angle. Fasten with the clip (7).

OPTIONAL

To mount the cylinder (8) for hydraulic opening, the tie-rod (1) must be removed, then add two bushes (2) and reuse the pins (3), bushes (2), washers (4) and nuts (5) used previously.

To connect the hoses, see the section ADJUSTMENTS FOR MACHINE USE.

Item (2): 2+2 (2+2 optional) bush $\varnothing 20.5/34 \times 23$

Item (3): 2+2 pins $\varnothing 20 \times 125$

Item (4): 2+2 washers $\varnothing 17$

Item (5): 2+2 nut M16

Item (6): 2 pins $\varnothing 15 \times 60$

Item (7): 2 clips $\varnothing 3$

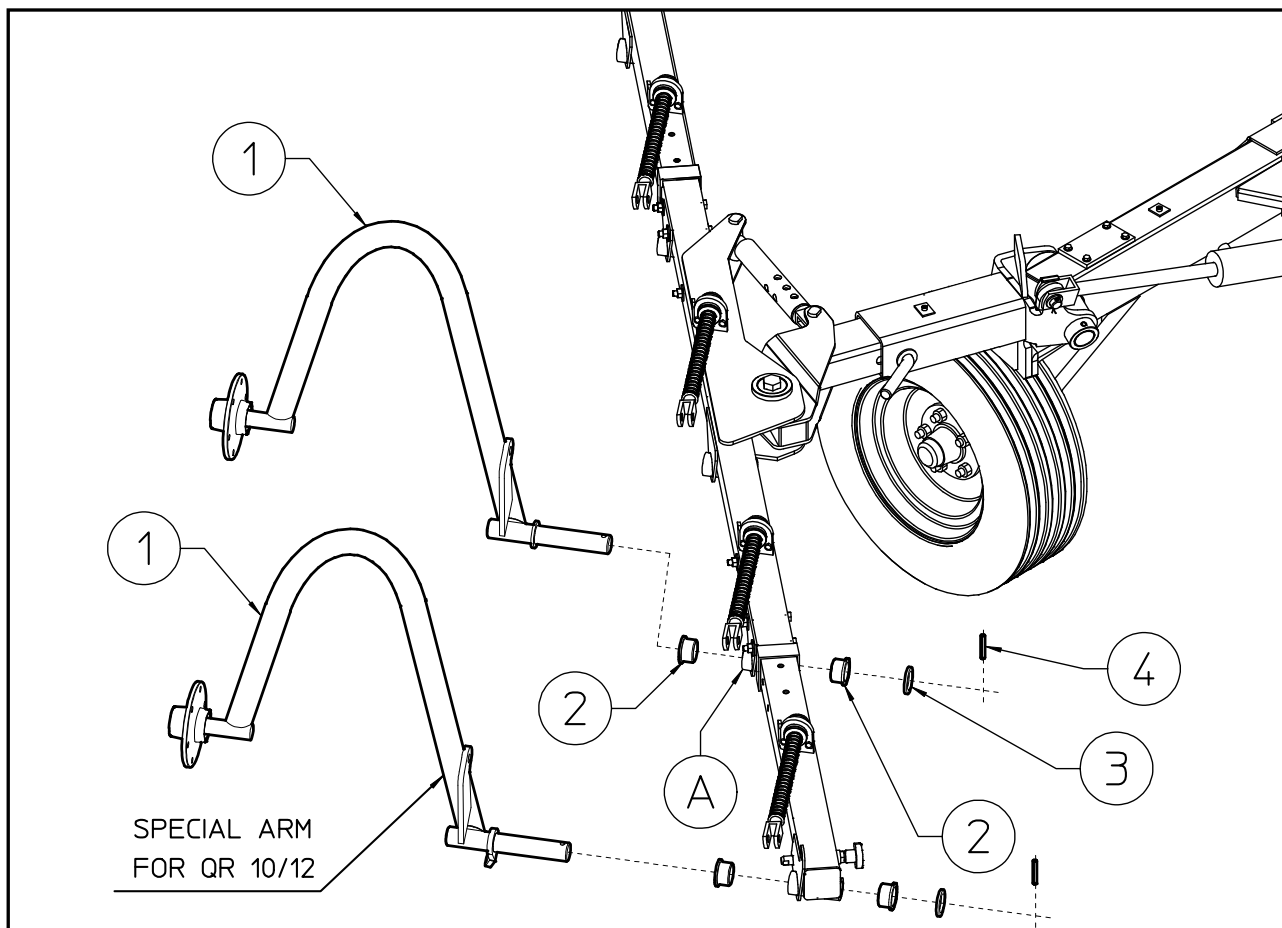

Insert the bushes (2) in section (A), then insert the arm (1) and fasten with washer (3) and pin (4).

Item (2): 16/20/24 bushings $\varnothing 35-42 \times 26$

Item (3): 8/10/12 washers $\varnothing 35-50 \times 5$

Item (4): 8/10/12 spring pins 8×50

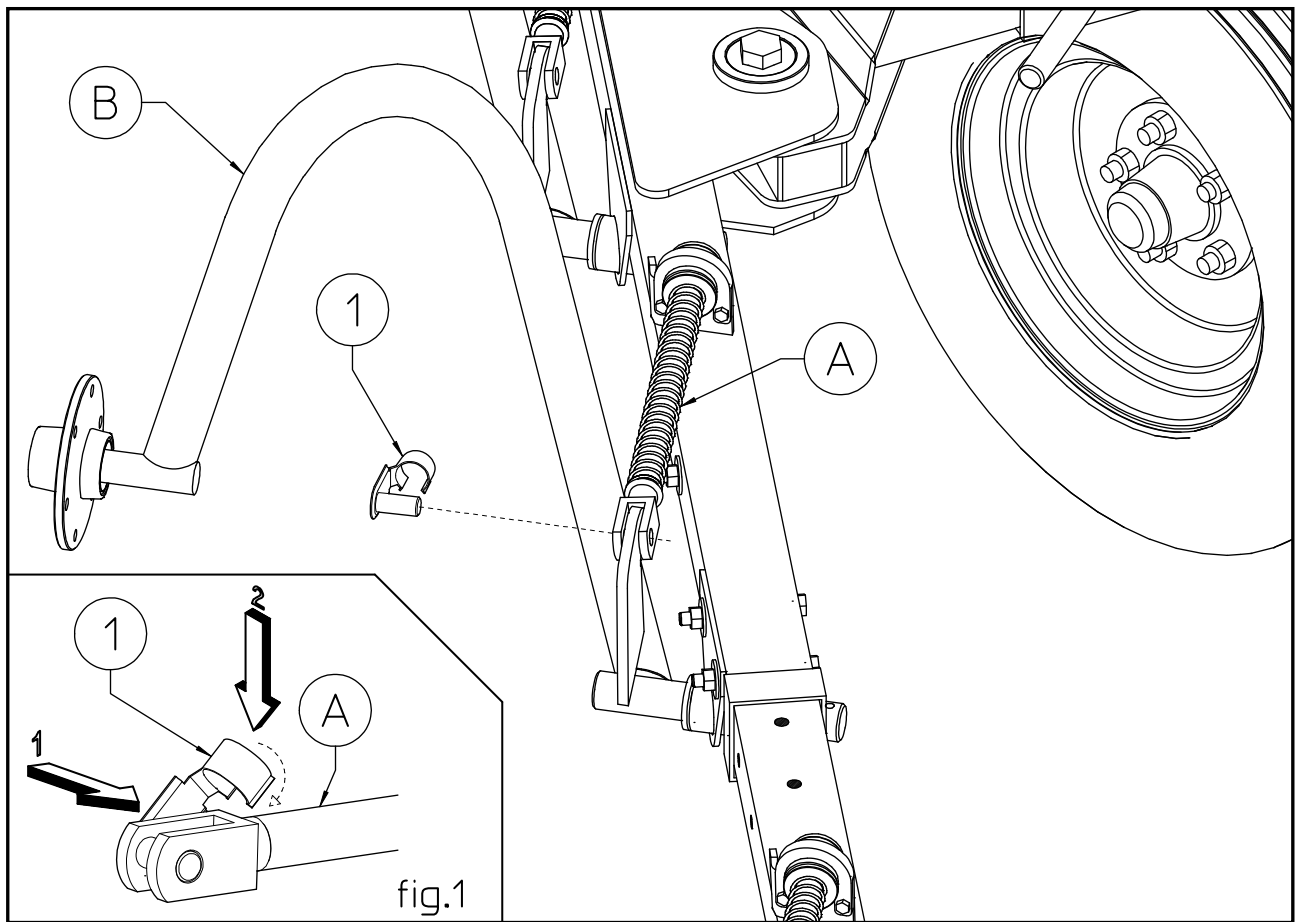

Attach the spring assembly (A) to the arm (B) using the automatic fastening pin (1). To fasten the pin in place, insert it into the fork and rotate it until it clips in place (Fig. 1).

Item (1): 8/10/12 pins $\varnothing 16 \times 36$

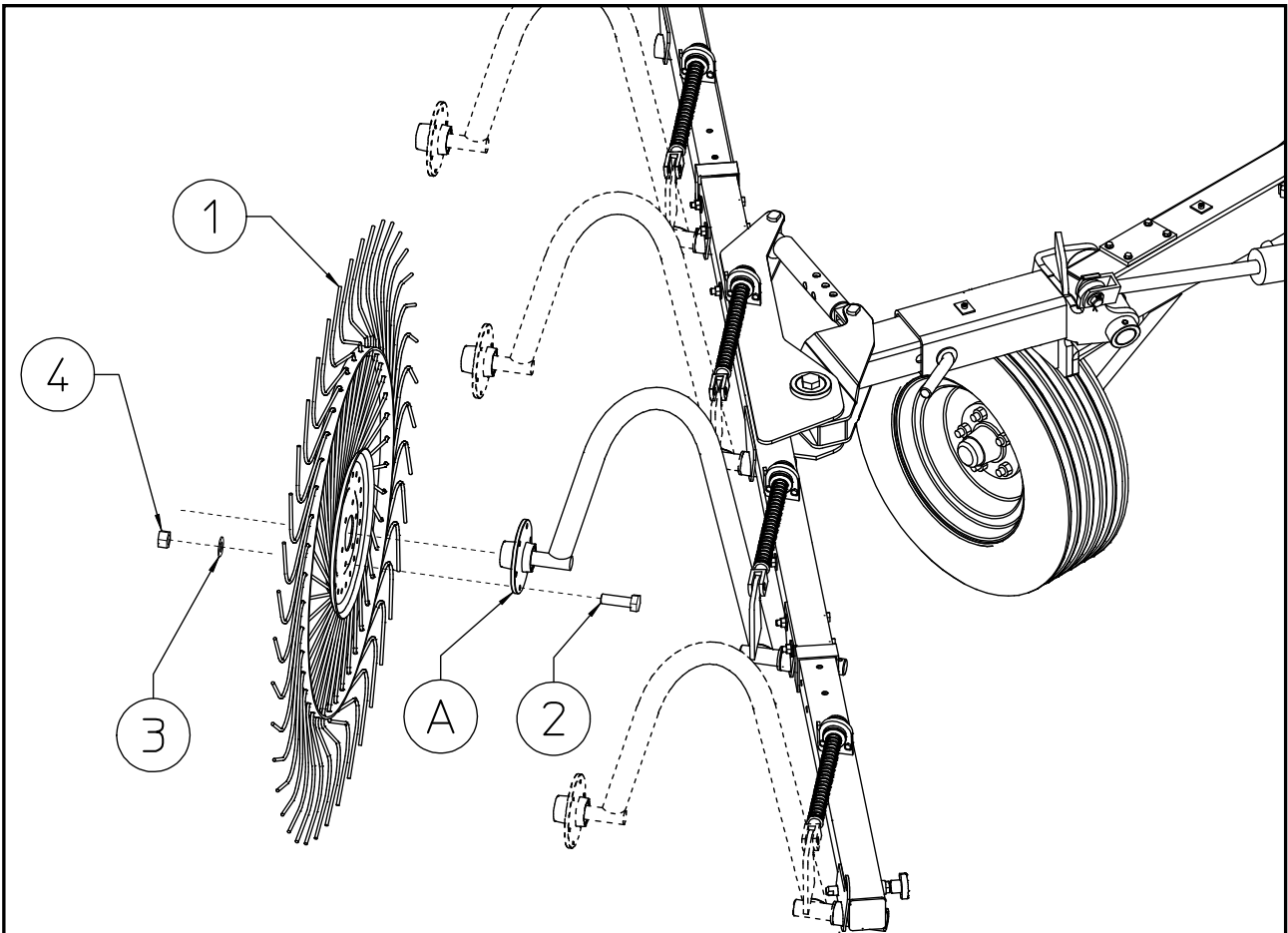

Attach the rake wheels (1) to the hubs (A) using screw (2) washers (3) and nuts (4).

Item (2): 48/60/72 screws M10x25 (25/64"x1")

Item (3): 48/60/72 washers $\varnothing 10.5$ (27/64")

Item (4): 48/60/72 nuts M10 (25/64")

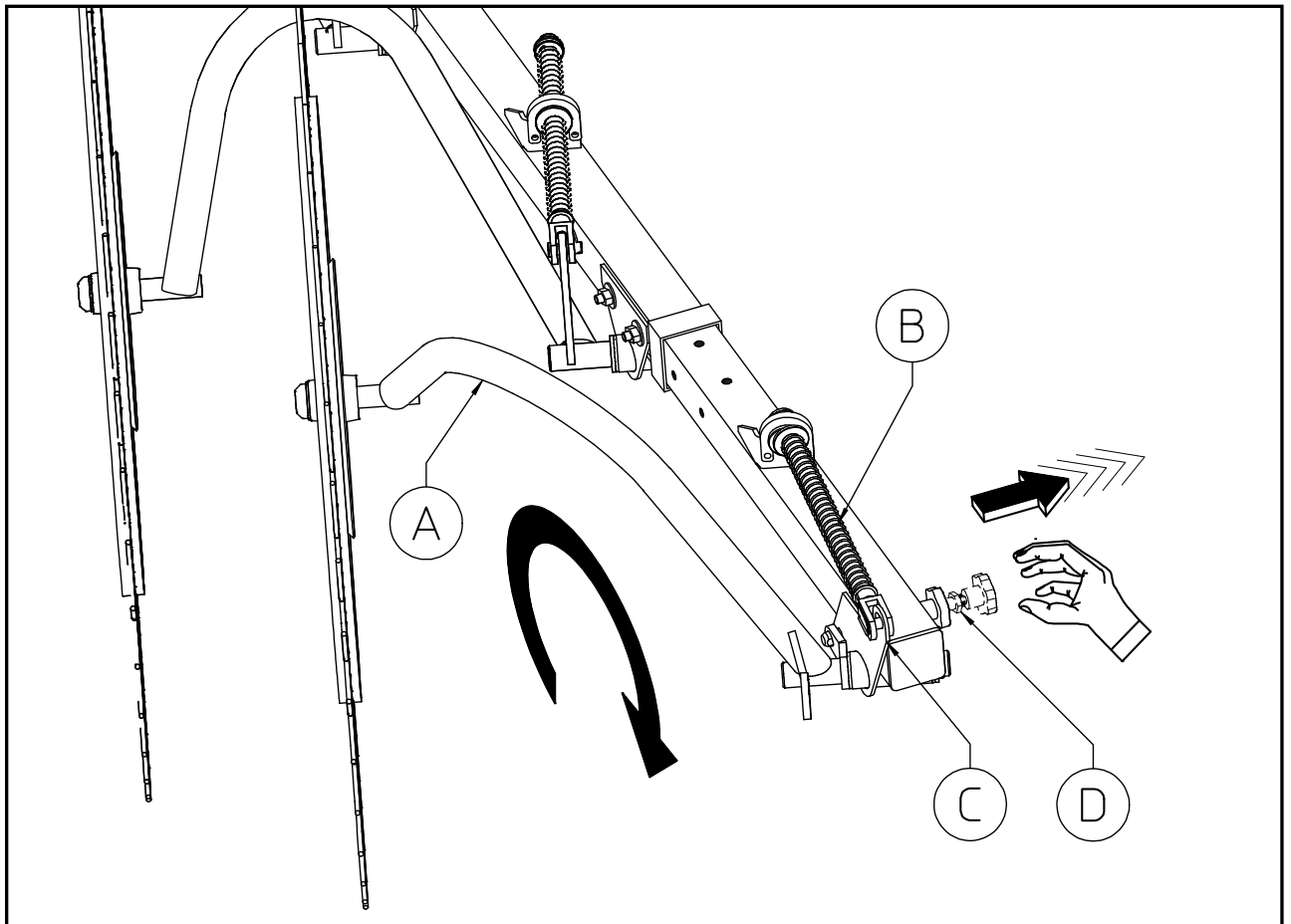

To lock the arm in the raised position, the spring assembly (B) must be released by sliding out the pin and hooking it onto the support (C). Then manually lift the arm (A), pull out the spring pin (D) and leave it at the hole on the arm bracket.

HYDRAULIC SYSTEM

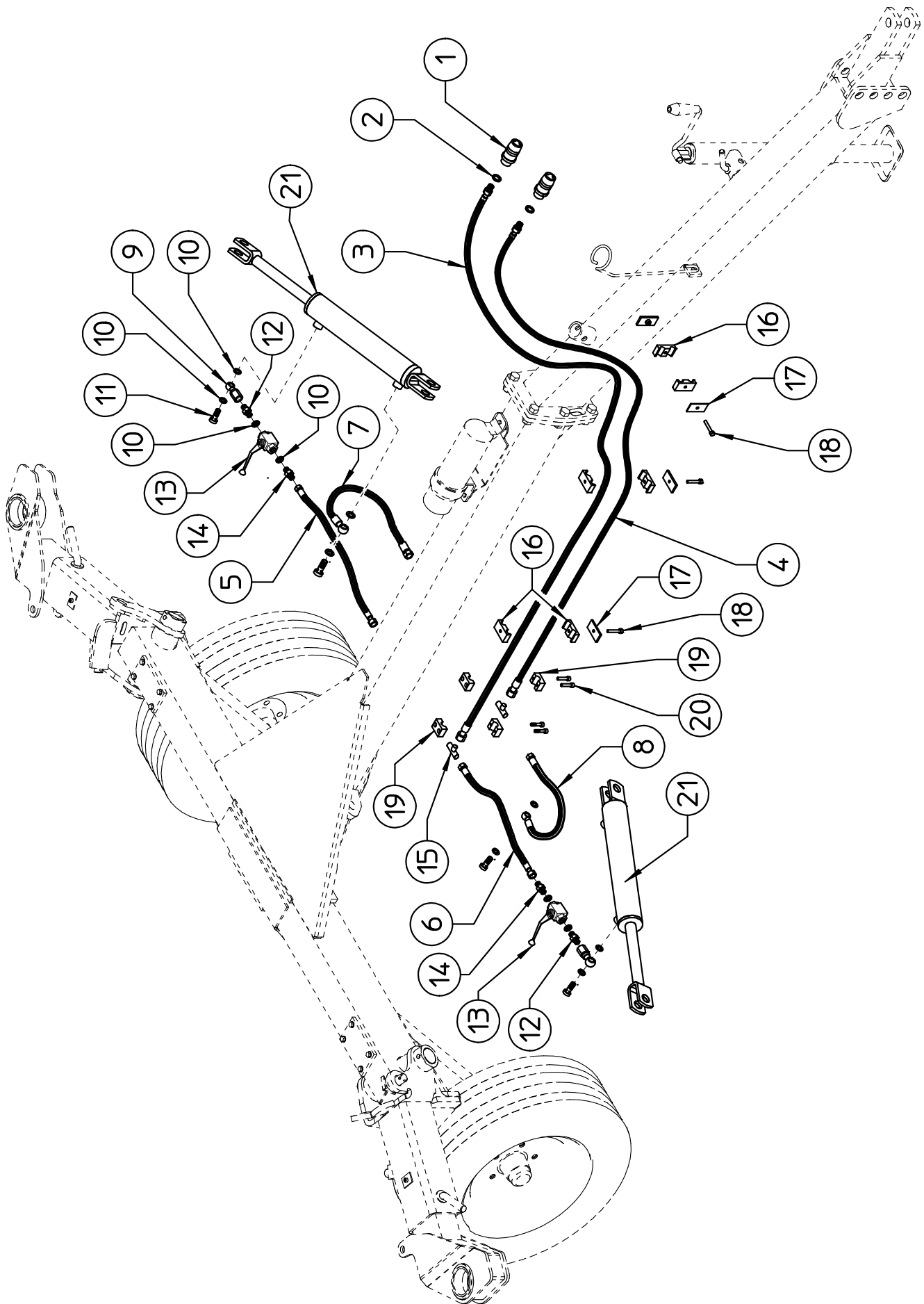

HYDRAULIC SYSTEM ASSEMBLY

Danger: the hydraulic cylinders are empty to start with, and the first time they are filled very dangerous uncontrolled movements can take place. It is recommended that the cylinders be filled with oil before connecting them to the machine, and the arms should be raised and lowered with the controls a few times in order to eliminate air from the circuit. These operations must be done in complete safety conditions, with the machine attached to the tractor and the operator sitting in the tractor driver's seat working the hydraulic controls, making sure that nothing and nobody is within the range of movement of the machine rake arms.

Assemble the cylinders and the oleo-dynamic system as shown. When using for the first time, make sure there are no oil leaks. If there should be any, tighten the pipe fittings

Attach the nipples (14) at valve (13) with washer (10) and connect this at reducer nipples (12) and fittings (9).

Connect the fitting hole (9) with washer (10) and fitting screw (11) on cylinders (21)

Connect pipe (5) and (6) at fitting (14) and union T (15)

Connect eye-ring end of pipes (7) – (8) to the other side cylinders (21) and the rotating female ends on the other union T (15)

Connect the rotating female ends of pipes (3) – (4) to union T (15)

Place washers (2) and connect the quick-release coupling (1) to the straight male ends of pipes (3) – (4)

Check to make sure that all connections are correctly fastened.

Attach the hose collar (16) and (19) to the lugs on drawbar, fastening on correctly position (see shown)

HYDRAULIC OPENING KIT (OPTIONAL)

DANGER. Assembly must be done carefully and accurately, for the safety of the person(s) doing the assembling and to ensure proper machine operation.

Assembly should be done on a flat, solid surface, using the proper tools and wearing suitable clothing, making sure that all people not involved in the assembly be kept at a safe distance.

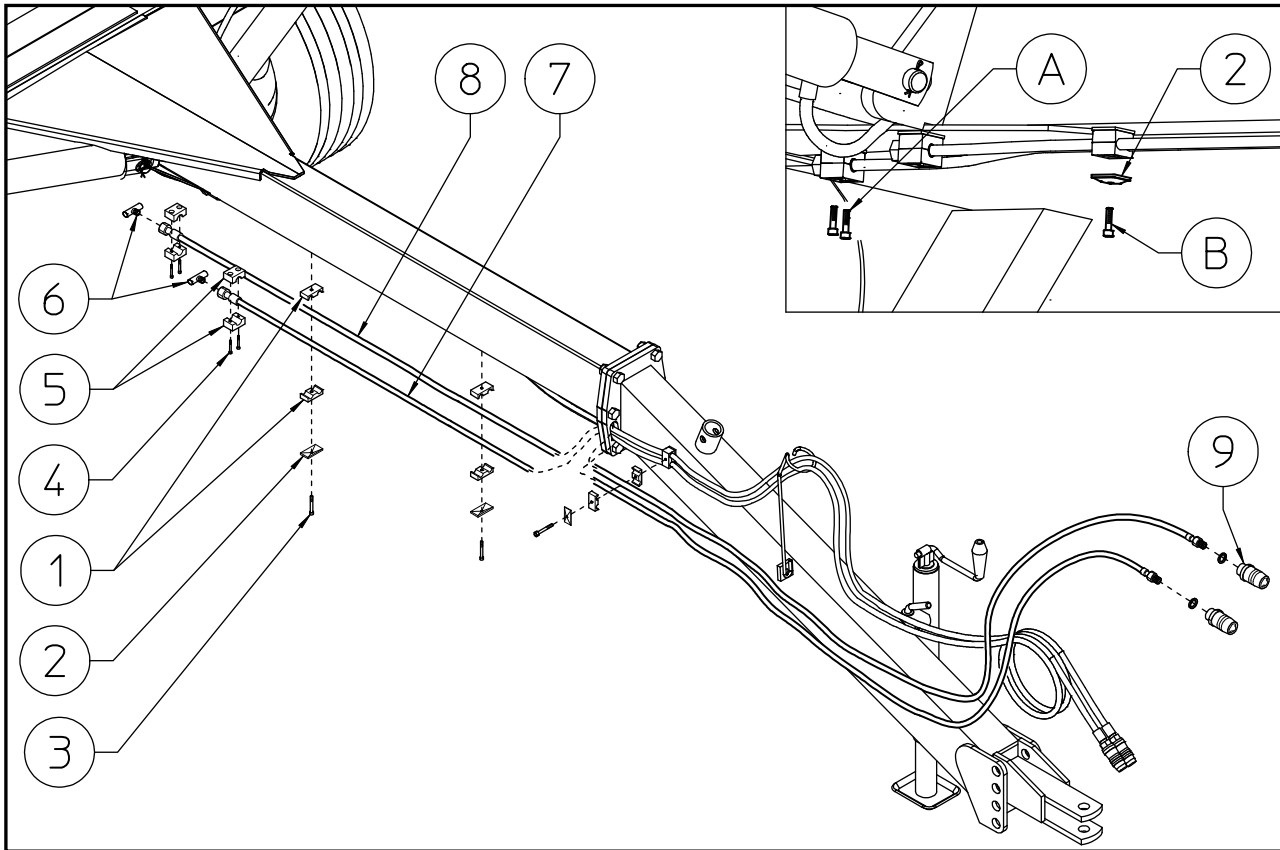

Attach the male T connectors (6) to the hoses (7-8).

Remove the screws (A) (which will not be used anymore), then attach the hoses (7-8) on the same spot and fasten them using the hose collars (5) and the screws (4).

Remove the screws (B) which will not be used anymore and the plates (2), pull the hoses (7-8) taut and fasten them in the proper places using the double hose collars (1), the plates already used (2) and the screws (3). Insert the hoses through the proper opening of the drawbar joint plates and, keeping them taut fasten them again on the same spot.

Attach the quick couplings (9) to the hoses (7-8).

In this step, you use:

Item 1: 6 double hose collars $\varnothing 16$ (5/8")

Item 2: 3 plat

Item 3: 3 screw M8x60 DIN 931 (0.3"x 2.3")

Item 4: 4 screw M6x60 DIN 912 (15/64"x 2.3")

Item 5: 4 hose collar $\varnothing 14$ (0.55")

Item 6: 2 male T connector 1/4"

Item 7: 1 hose 1/4" lenght 4950mm (194.88")

Item 8: 1 hose 1/4" lenght 5100mm (200.78")

Item 9: 2 rapid coupling 1/2"

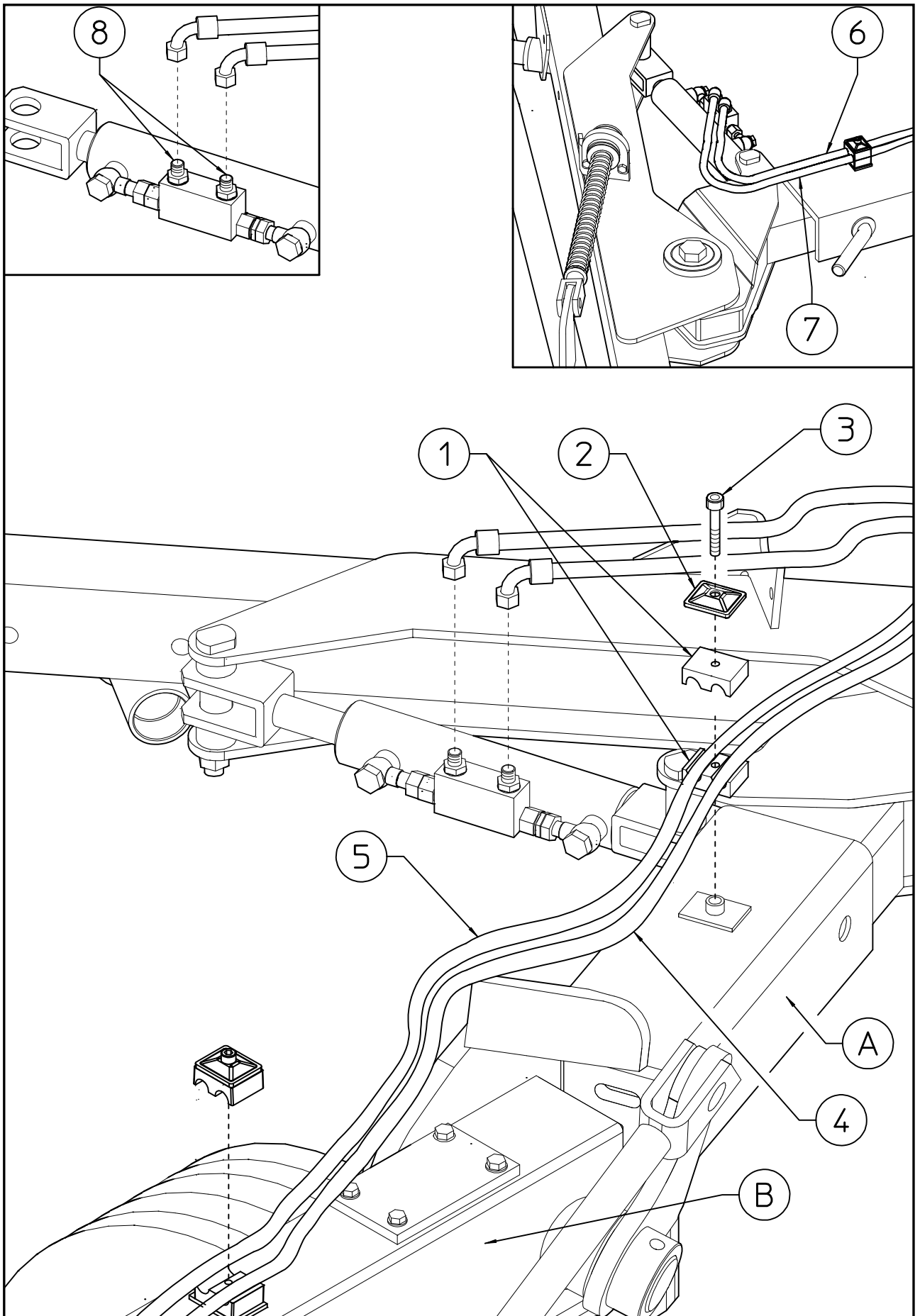

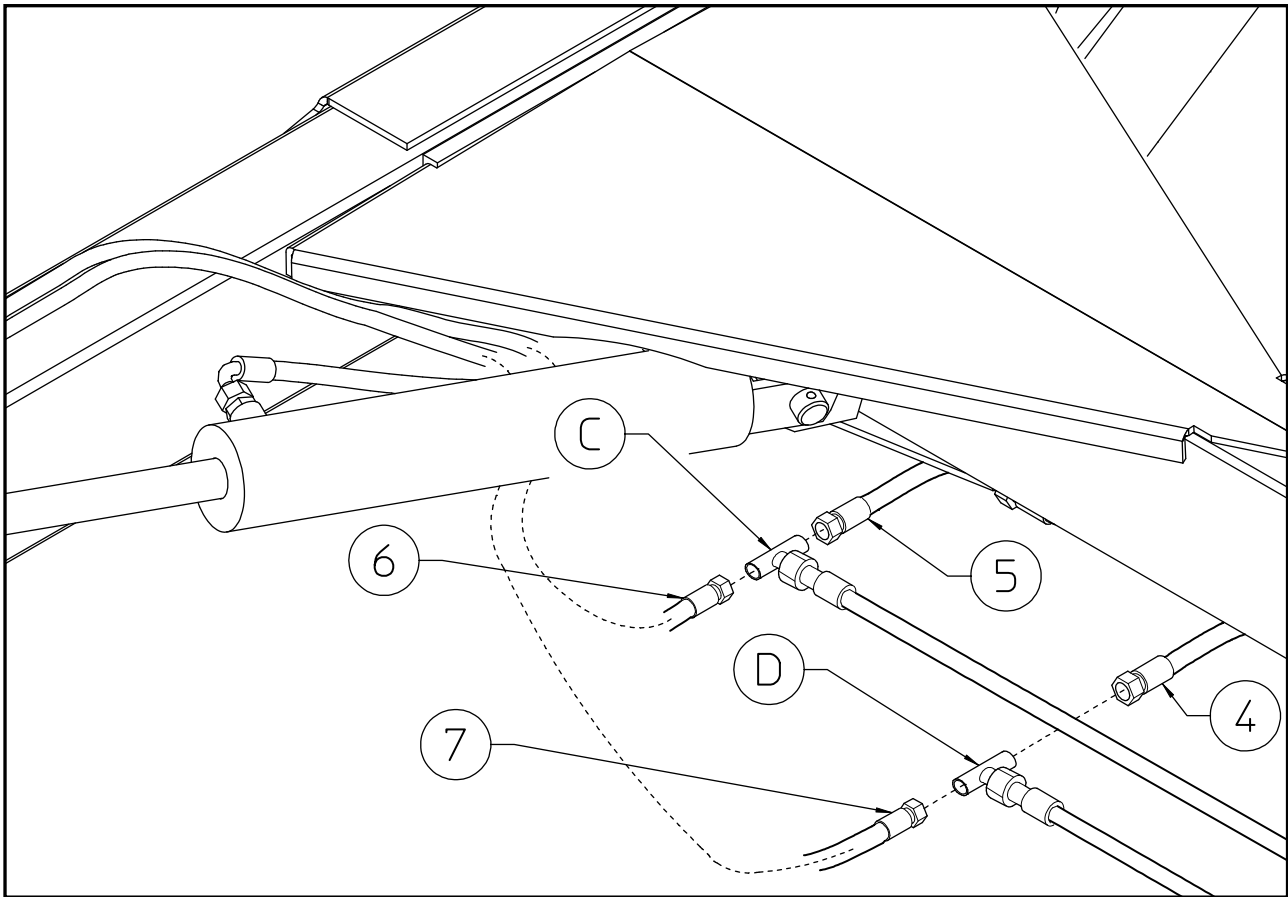

Mount the hoses (4-5-6-7) to the connectors (C-D). At this stage, keeping the hoses well extended, fasten them by means of the double hose collars (1), plats (2) and screws (3) to the main frame (B) and to the sliding arm (A). Finally, screw the hoses (4-5-6-7) to the cylinders nipples (8).

In this step, you will use:

- Item (1): 8 double hose collars $\varnothing 16$ (5/8")
- Item (2): 4 plats
- Item (3): 4 screws M8x35 (0.3"x1.37")
- Item (4): 1 hose $\frac{1}{4}$ " length 2150mm (84.65")
- Item (5): 1 hose $\frac{1}{4}$ " length 1900mm (74.80")
- Item (6): 1 hose $\frac{1}{4}$ " length 2000mm (78.74")
- Item (7): 1 hose $\frac{1}{4}$ " length 2050mm (80.71")

CENTER WHEEL KIT (OPTIONAL)

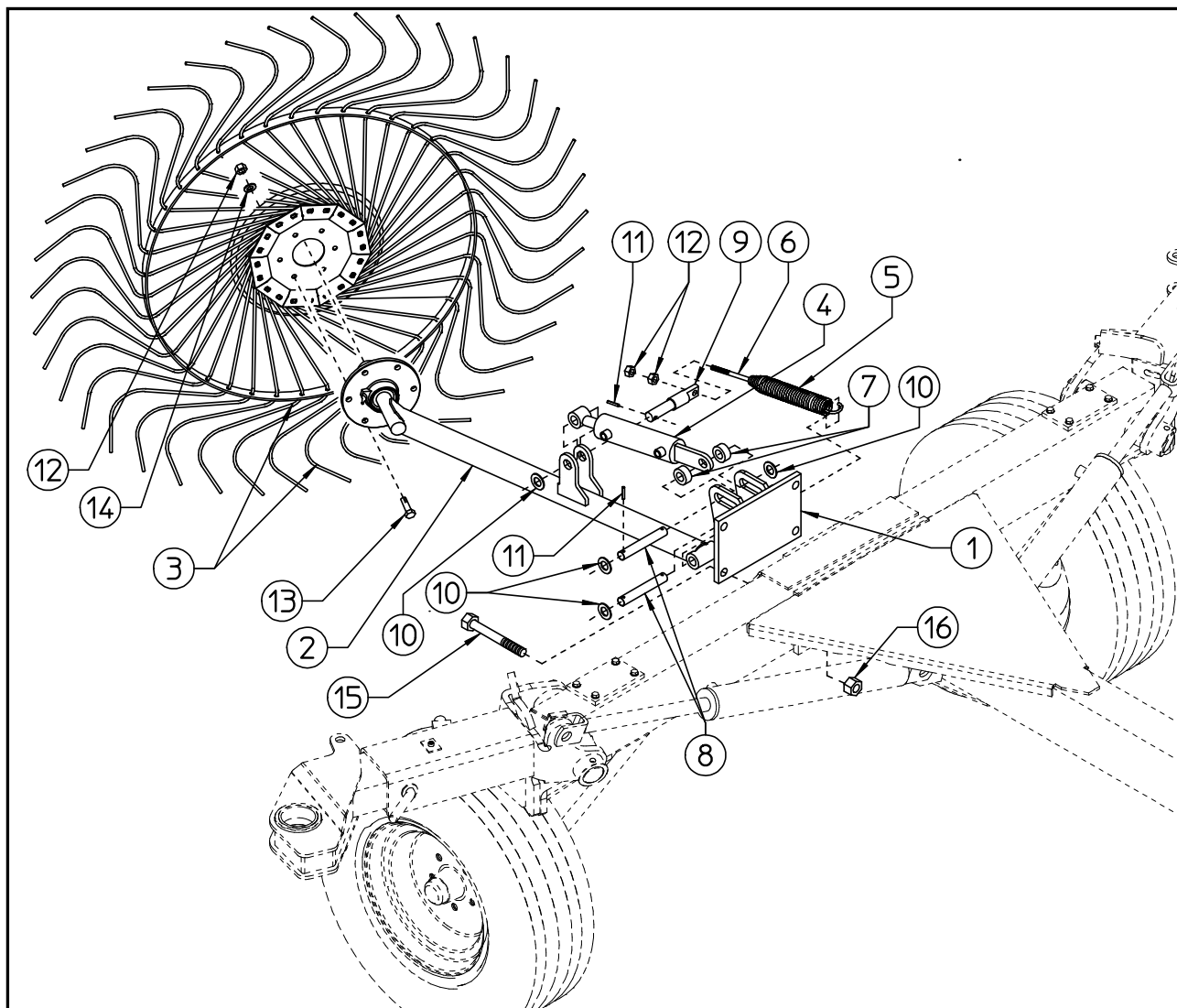

To assemble the Center Rake Wheel Kit, proceed as follows:

Remove the four central screws that connect the horizontal drawbar to the main frame and attach the plate (1) using the 4 long screws (15) that are supplied and the nuts (16).

Assemble the arm (2) and hydraulic cylinder (4) to the plate (1) using the two pins (8), the washers (10) and the spring pins (11).

Connect the arm and cylinder with the milled pin (9), the washer (10) and the spring pin (11).

Attach the spring (5) first with the hook in the hole in the plate (1) and then the screw (6) in the hole in the milled pin (9). Tighten the nuts (12) on the screw, letting a few millimeters (1/8") protrude. The spring tension must be adjusted later according to the desired pressure of the rake wheel on the ground.

Attach the rake wheel (3) to the arm (2) using the screws (13), washers (14) and nuts (12).

Assembly of hydraulic system for center rake wheel kit.

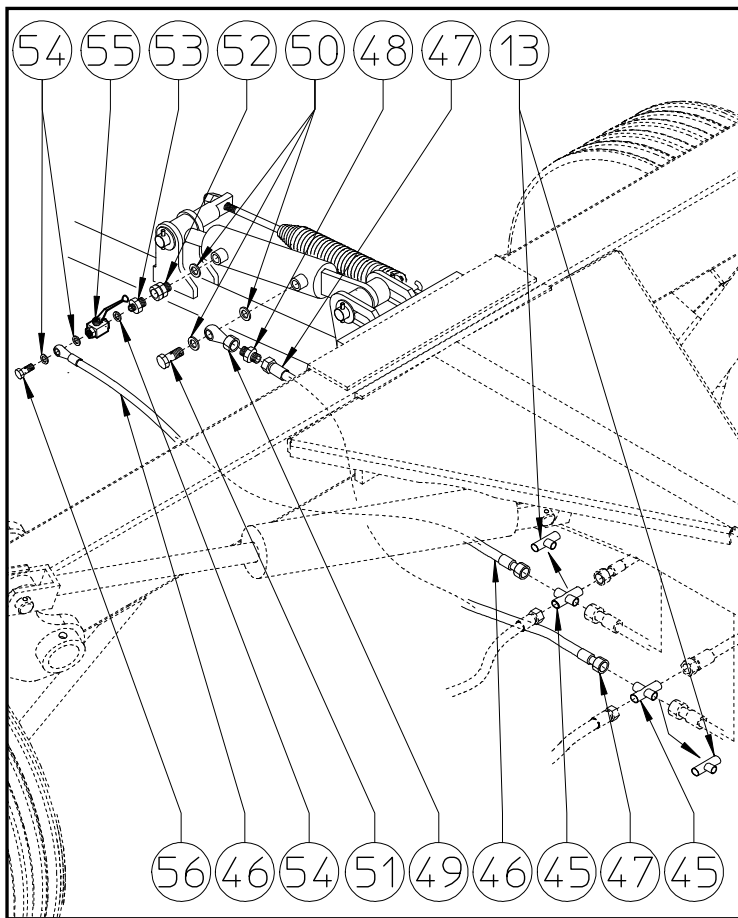

Attention: before proceeding check to make sure the hydraulic circuit is not under pressure. Wear individual protective devices (gloves, safety goggles, etc.). When loosening the fittings work carefully and cautiously.

Remove the tee fittings (13) found and replace them with the crosses (45).

Attach fitting 49 on relevant cylinder's base hitch through copper washers 50 and screw 51. In this phase do not tighten completely screw 51.

Fit nipple 48 to fitting 49. In this phase do not tighten completely nipple 48.

Attach female side 1/4" of short hose 47 to fitting 45 and female side 3/8" to nipple 48. Now position correctly hose 47 so that it does not suffer deformations or crushing during cylinder working phase. Once this is done, tighten all fittings which were previously left loose.

Attach fitting 52 to relevant hitch on rod's side of cylinder together with copper washer 50.

Fit to tap 55 the nipple 53 with copper washer 54.

Fit tap 55, copper washer 54 and nipple 53 to rotating fitting 52.

Position the tap 55 opening lever up so that use is easy and does not interfere with anything else. Fit female side 1/4" of long hose 46 to fitting 45 and eye side 1/4" to tap 55 through copper washers 54 and screw 56. In this phase do not tighten completely screw 56.

Now position correctly hose 46 so that it does not suffer deformations or crushing during cylinder's working, then, tighten completely screw 56.

The center rake wheel kit must be used to move the product to be raked into the center area before forming the swath.

The hydraulic cylinder is operated in parallel with the rake arms and therefore no additional operations are required. The center rake wheel normally moves very fast; this does not mean it is not working properly. The compensating spring must be adjusted with the two nuts on the screw so as to obtain the right ground pressure according to the desired working conditions.

Tighten the nut to decrease ground pressure.

Loosen the nut to increase ground pressure.

If the raking conditions do not require the use of the center rake wheel the tap (55) makes it possible to keep the arm from lowering.

To lock out the central wheel kit:

Activate the tractor hydraulics and raise the rake arms until they reach the stops.

Stop the tractor engine and remove the key.

Wait until all moving parts have stopped. Close the tap (55) at the rear of the rake.

5) Adjustments for machine use

The machine must be adjusted according to the specific work requirements. Thus the various adjustment possibilities will be described, so you can choose that which best suits your work requirements. Before attaching the machine, make sure that it cannot accidentally start

Attachment of machine to the tractor

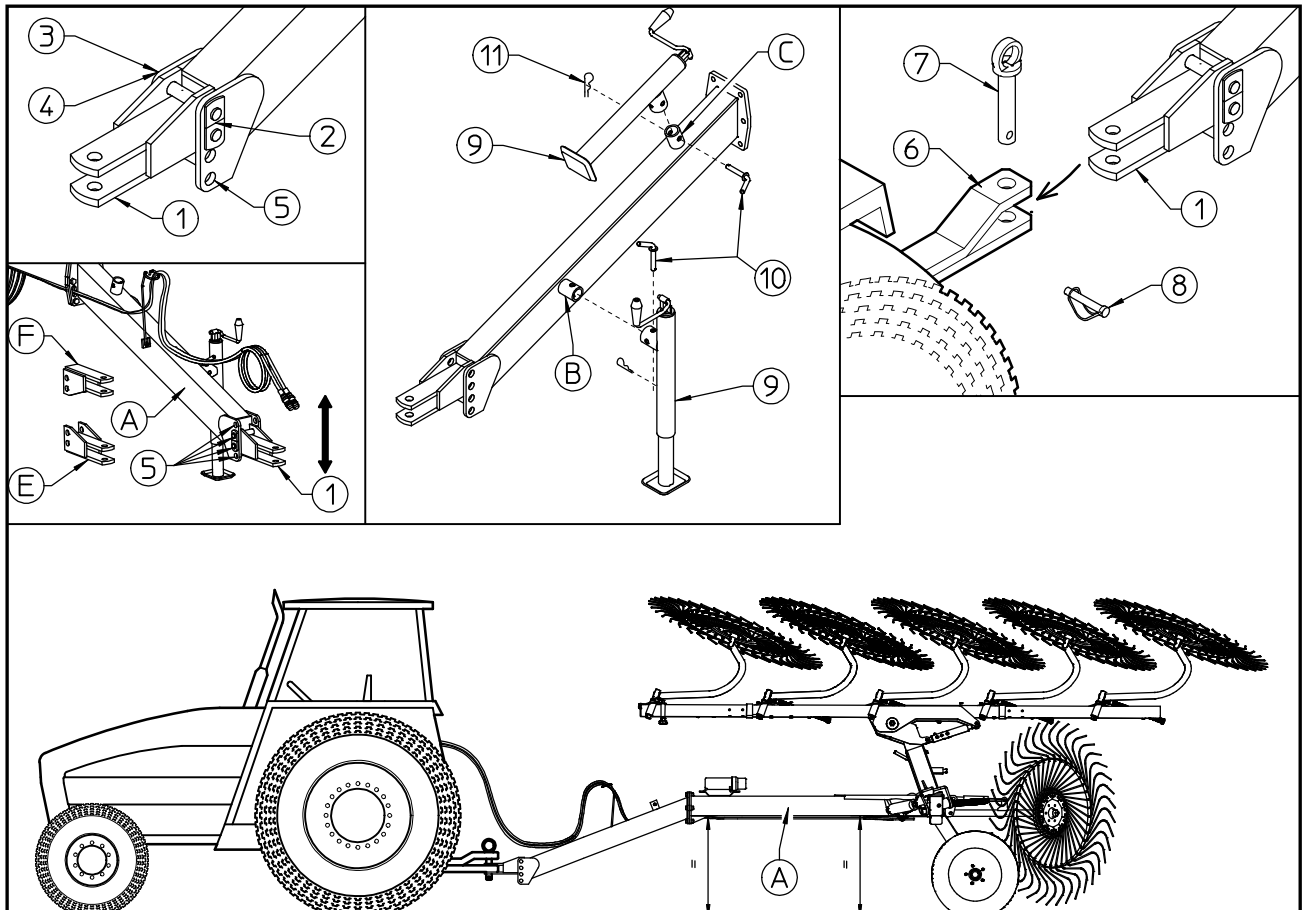

Attaching the machine to the tractor is extremely simple: all that needs to be done is to couple the drawbar (1) to the tractor hitch (6) with pins (7)-(8) of the right shape and size. Always use extreme caution when the tractor is moving in reverse toward the machine. Once the machine is hitched, remove the parking stand (9) from point (B) by removing the clip (11) and pin (10), placing it in position (C), and fastening it in place with pin (10) and clip (11).

Before starting the machine to test its operation, check to make sure it is positioned correctly with regard to the ground. To do this, check that the horizontal drawbar (A) is parallel with the ground, i.e. the tip is pointing neither up nor down.

If this is not the case, the hitch to the tractor (1) must be adjusted, moving it to the free holes (5). To do this, remove the pins (2), washers (3) and screws (4), choose the right position and fasten back in place with the pins, washers and screws used previously.

Now check the machine operation, remembering that this must be done in a large enough area and making sure that no one is with the machine's operating range.

Uncoupling the machine

Attention - Park the machine on even fairly level ground

Preferably park the machine in transport position with the transport lock installed.

- Block the machine with wheel chocks.
- Disconnect hydraulic hoses.
- Store hydraulic hoses in their support.
- Unhook safety chain. (If so equipped)

To prevent the implement hitch from raising rapidly, always position rake arms up against the stops or down with the finger wheels on the ground to prevent the rake from becoming unbalanced and tipping back when uncoupling.

- Remove parking stand to transport position.
- Install parking stand on tongue jack mount.
- Secure parking stand with pin and clip.
- Turn parking handle to lower the jack base to the ground and keep turning until the tongue weight is off of the tractor hitch (2).
- Remove hitch pin.

Machine is uncoupled.

When parking the machine for a long period, we recommend raising the rake arms until they butt against their stop in order to depressurize the hydraulic circuit.

Grease and lubrication

After the assembly, prior to any movement, lubricate the pivot points and sliding of the machine.

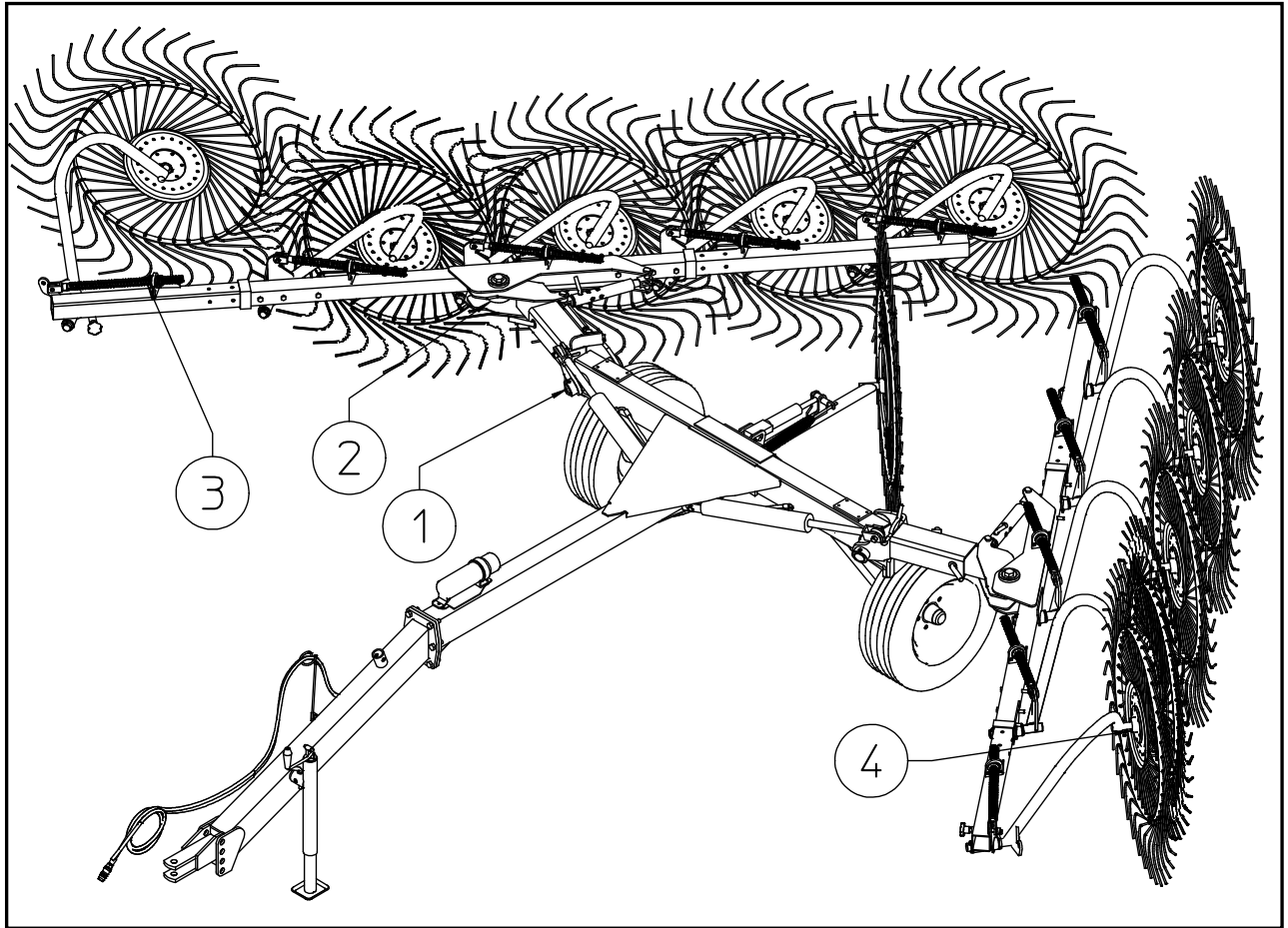

Then, as described below, lubricate after a certain period of work.

Every 25 hours

- Pin (1)
- Pin (2)
- Spring group (3)

Every 40 hours

- wheel hubs (4)

At the start of each season

Read the operator's manual.

Check tire pressure.

Lubricate all grease points.

Torque transport wheel lug nuts. 120 ft. lbs. (16.3 daNm)

THE FOLLOWING SHOULD BE NOTED IF THE MACHINE IS SCRAPPED:

The machine consists mainly of ferrous material which must be disposed of according to the regulations in force in the country concerned.

There is also a small amount of plastic which must be disposed of according to the regulations in force in the country concerned.

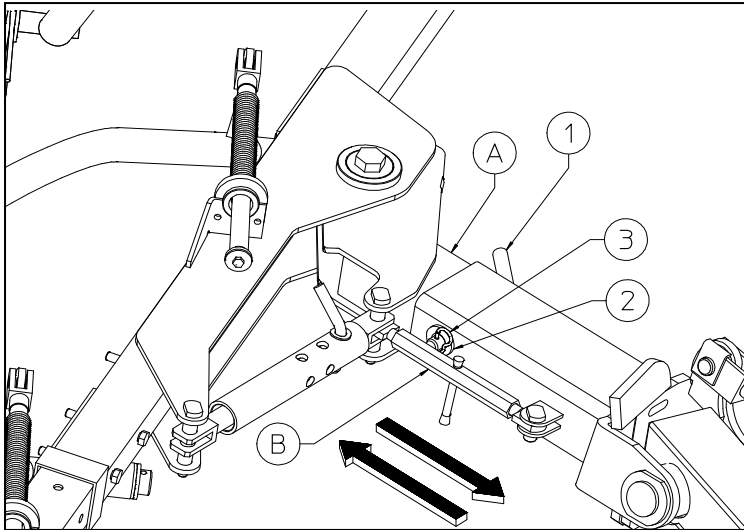

Setting working width

Working width can be adjusted by sliding the telescopic arm in or out. This will change the windrow width but not effect the rake arm angle

To change working width:

Remove pin (1).

Slide the telescoping arm (A) to the desired position with the tie rod (B).

Install pin (1) to lock the telescoping arm (A) in place. Secure pin (1) with washer (2) and retaining clip (3).

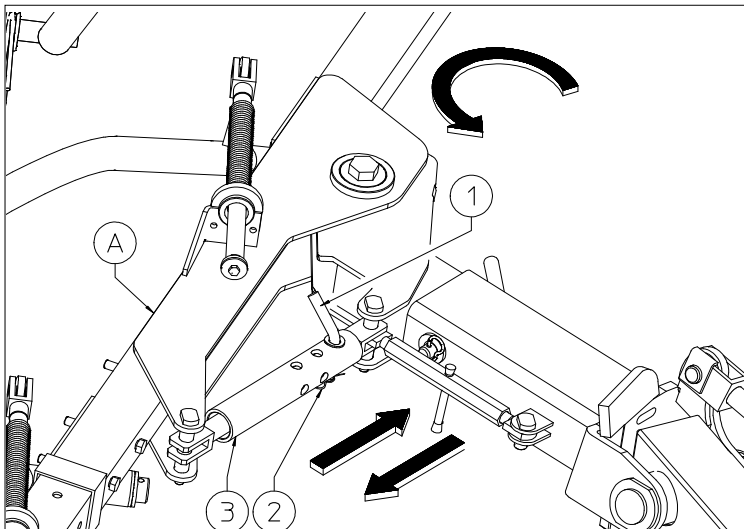

Setting rake arm angle

The hay rake arms (A) can be pivoted and locked into different positions using tie rod (3) and pin (1). Change the rake wheel angle by rotating hay rake arms.

The hay rake arm can be pivoted to obtain a different working angle and further variation of the swath. Pin (1) is inserted in the different holes the tie rod (3) and fastened with the clip (2).

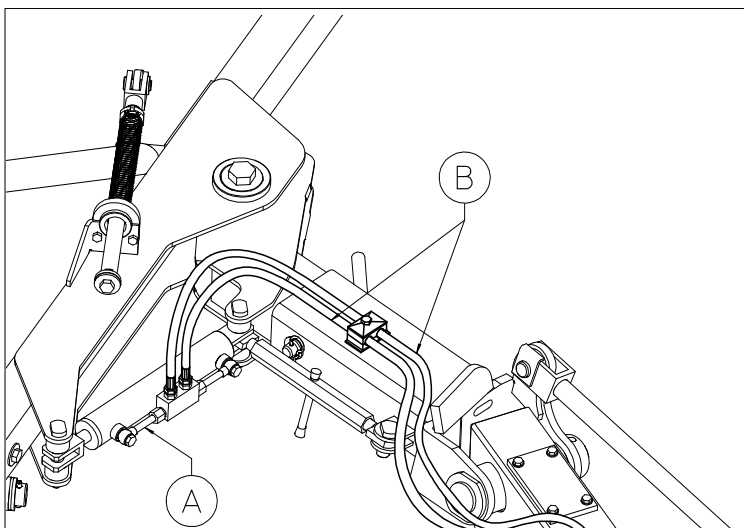

OPTIONAL

A hydraulic opening kit is available for adjusting the working angle.

Two cylinders (A) are fitted, which are controlled by the pipes (B), making it possible to obtain the desired section angle position without getting down from the tractor.

Adjusting arm ground pressure

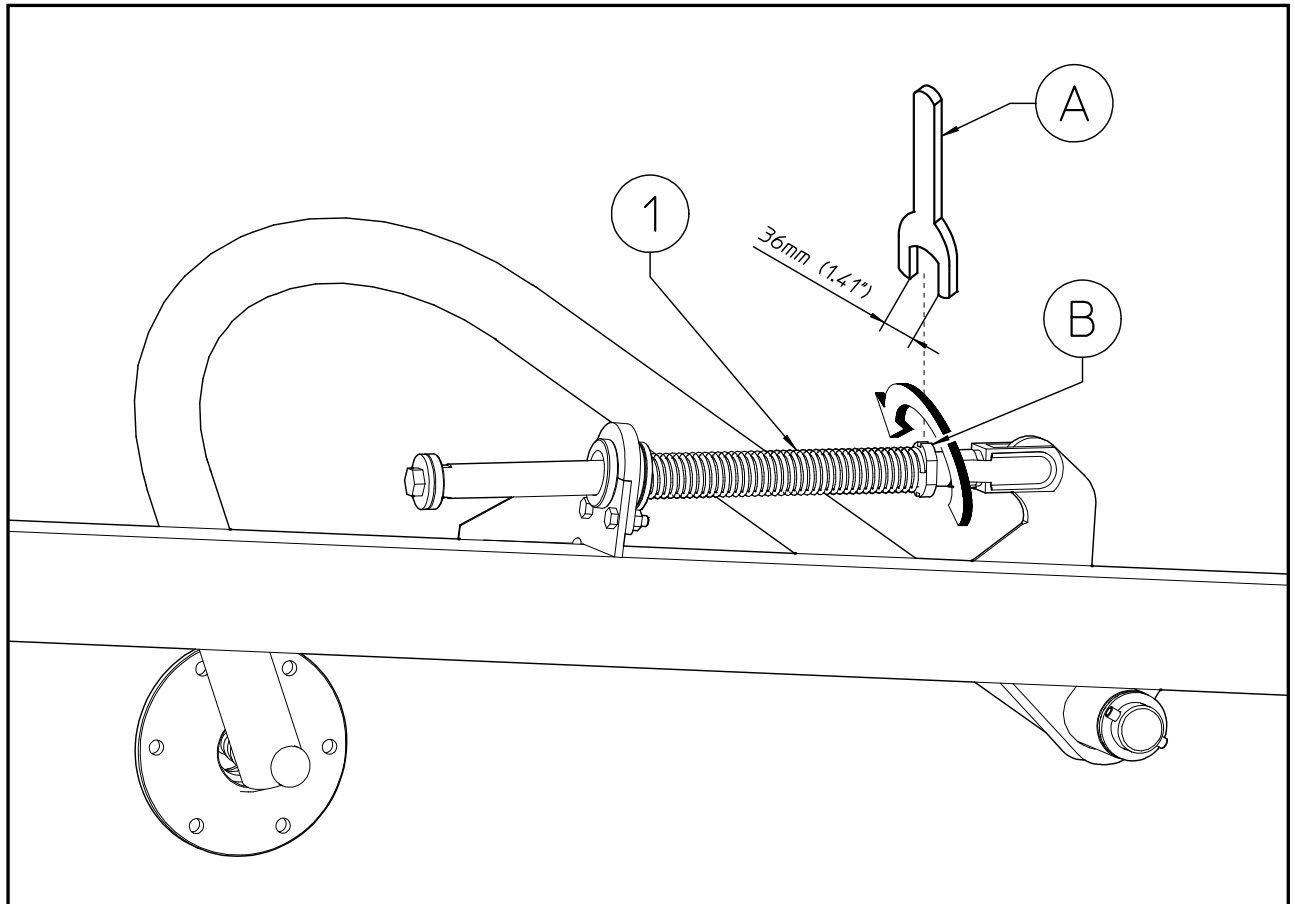

The pressure of the rake wheels against the ground can be adjusted with the spring (1).

- Lower the rake arms, using the hydraulic lever on the tractor.
- Adjust the rake wheel pressure by turning the adjustment nut (B), using wrench "A" (not included).
- Compressing the spring (1) reduces the pressure against the ground.
- Loosening the spring (1) increases the pressure against the ground.

The rake wheels are driven by contacting the ground. Adjust the wheel ground pressure for good raking action without damaging the crop. Ground speed affects raking performance. Be sure to operate the rake at recommended raking ground speeds when checking ground pressure.

6) Transport by road

Attention:

When the hay rake arms are lifted, the shape of the hinges carries the weight toward the tractor and makes it possible to decrease the machine dimensions.

Check carefully during the lifting stage to make sure that parts of the machine do not touch parts of the tractor.

Check to make sure that with certain tractors during transport operations, while steering or when moving over uneven ground the hay rake arms do not touch parts of the tractor, with the risk of causing damage to both machines.

If it is possible that there may be contact between parts of the hay rake and parts of the tractor, it is recommended that the angle of the arms be increased before lifting them. This operation brings them farther away from the tractor and creates a situation of greater safety.

Danger: Crushing hazard

Keep a safe distance from machine when raising or lowering arms, or when implement is in transport position.

Lock arms in raised position before transport and before working under this machine.

Before placing the machine into transport position:

Make sure the rotating parts have come to a complete stop. Check and move away any person located in the rake arm pivoting area.

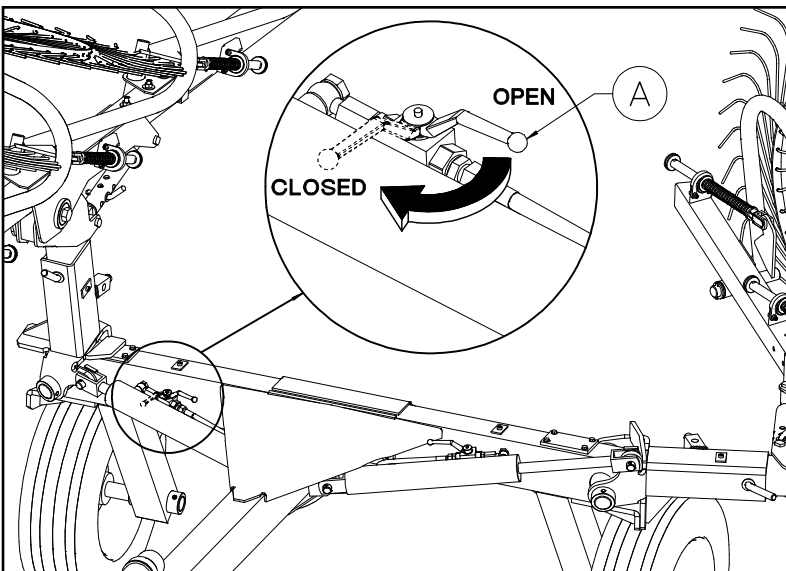

Set the machine into transport position.

From the working position:

- Activate the tractor hydraulics and raise the rake arms until they reach the stops.
- Close the cylinder valve by turning the lever (A).
- Make sure that all safety signs and reflectors are installed, clean and visible.

Please check that there aren't oil's losses these could compromise the machine's stability.

Do not operate tractor hydraulics while in transport position.

Conformity with the road regulations

Before driving the machine on public roads, ensure that the machine meets current highway code regulations. If the machine is over the maximum legal size, follow the local regulations for special transports of oversize equipment.

Check that the reflecting signalling panels are clean and that any lighting equipment functions before going on public roads.

Before going on public roads:

- Make sure rake arms are locked.
- Make sure the hitch pin is installed with the lock pin secured.

Immediately replace any worn or damaged signalling panels or lights.

Instructions for work

DANGER - Before placing machine in work position:
Check that nobody is within the machine pivoting area.
If there is someone, make sure the person moves away.

Setting the machine into work position

From the transport position:

- Stop tractor engine and remove the key.
- Turn the tap lever (A) in open position.
- Get back on the tractor and lower the rake arms to the working position with the hydraulic cylinder.

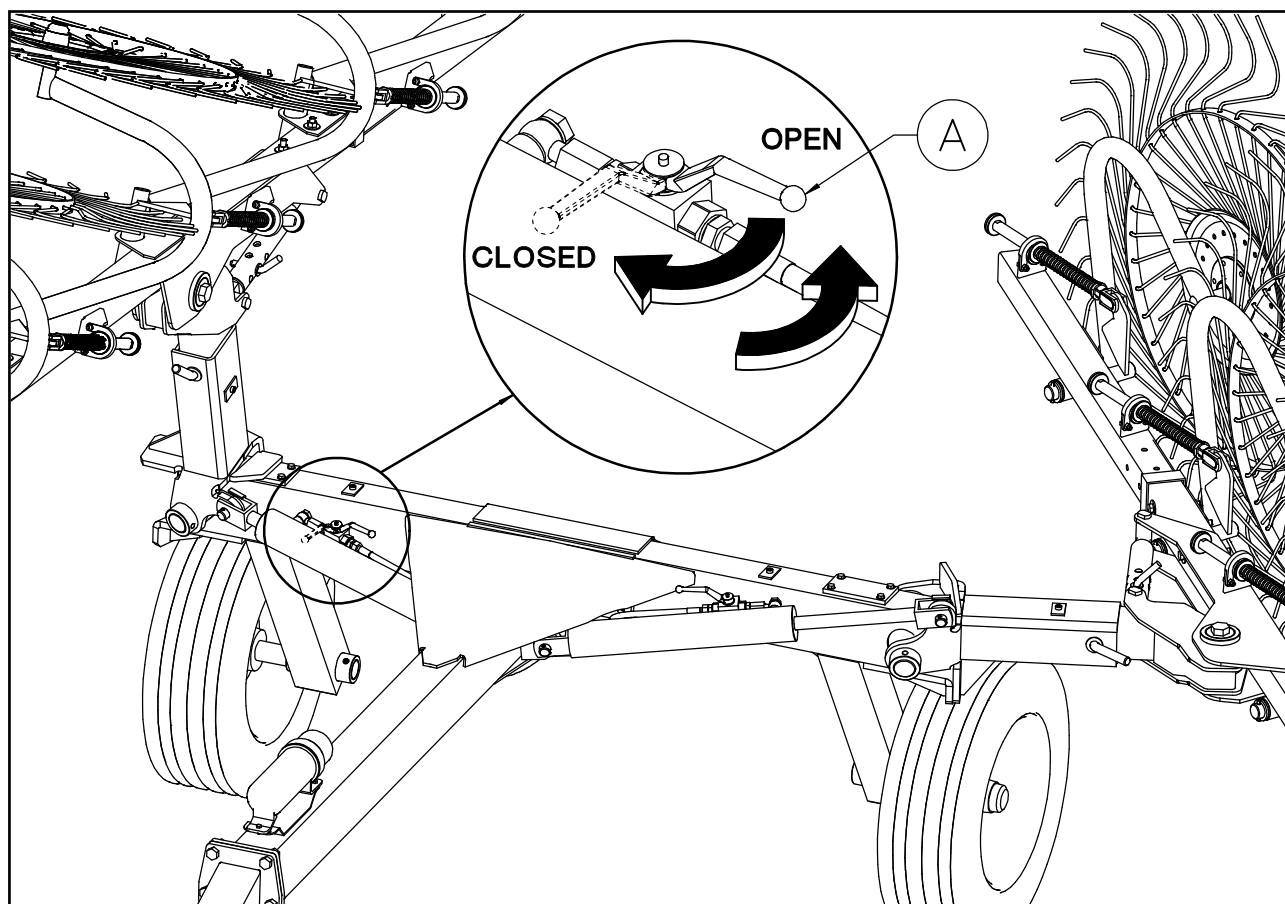

The machine is in working position.

The tractor hydraulics must be set to float mode during operation

Adjustment in work position

Minimum and maximum width and windrow specifications

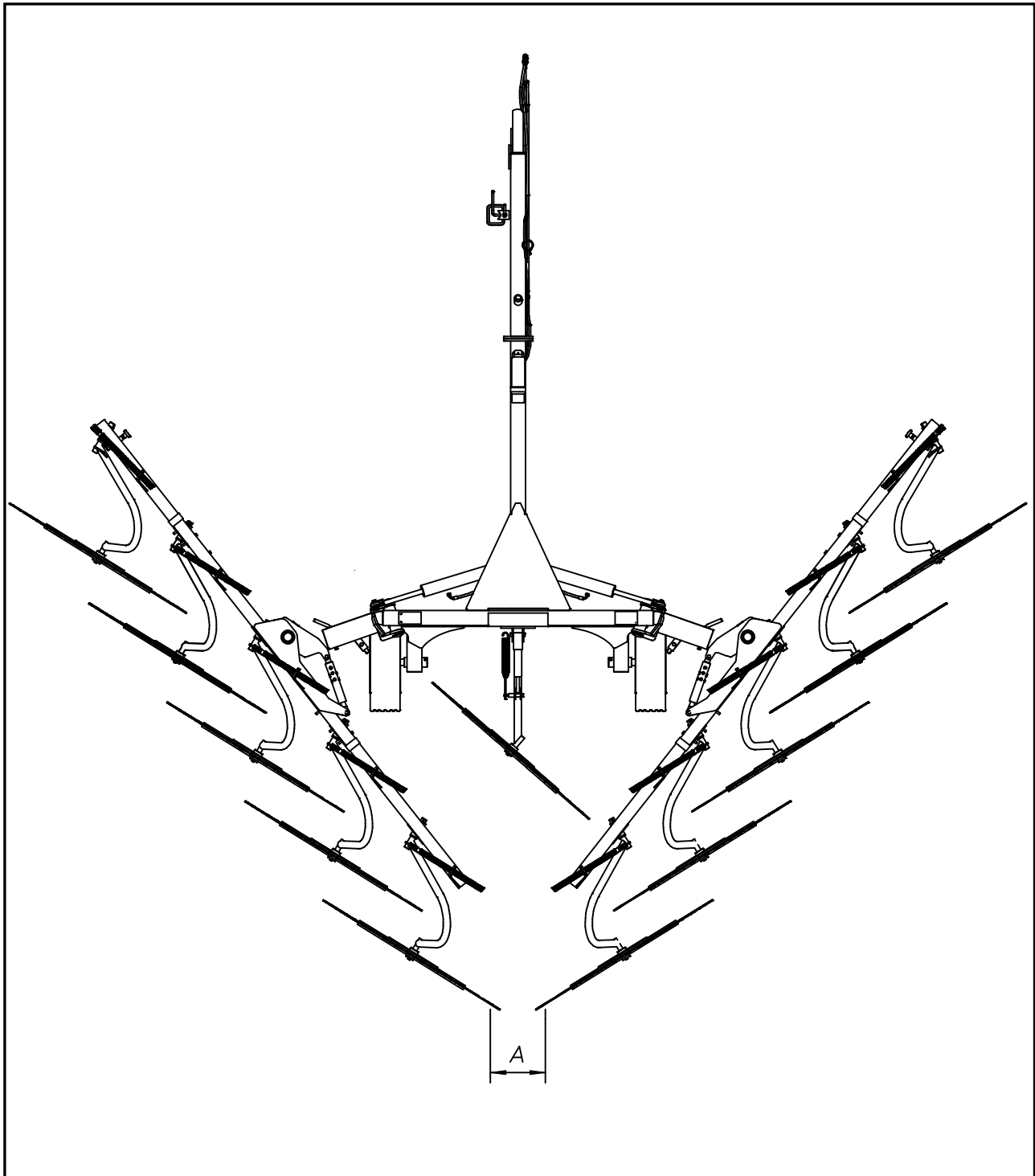

MODEL	QR 8	QR 10	QR 12
Minimum Windrow Width (A)	3' (0,9 m)	3' (0,9 m)	3' (0,9 m)
Maximum Windrow Width (A)	6' 7" (2 m)	6' 7" (2 m)	6' 7" (2 m)
Minimum Working Width	16' 4" (5 m)	19' (5,8 m)	21' 8" (6,6 m)
Maximum Working Width	18' (5,5 m)	21' (6,4 m)	24' 6" (7,5 m)

will vary depending on crop conditions.

DANGER - Before placing machine in work position:
Check that nobody is within the machine pivoting area.
If there is someone, make sure the person moves away.

For raking on one side only

LEFT SIDE ONLY

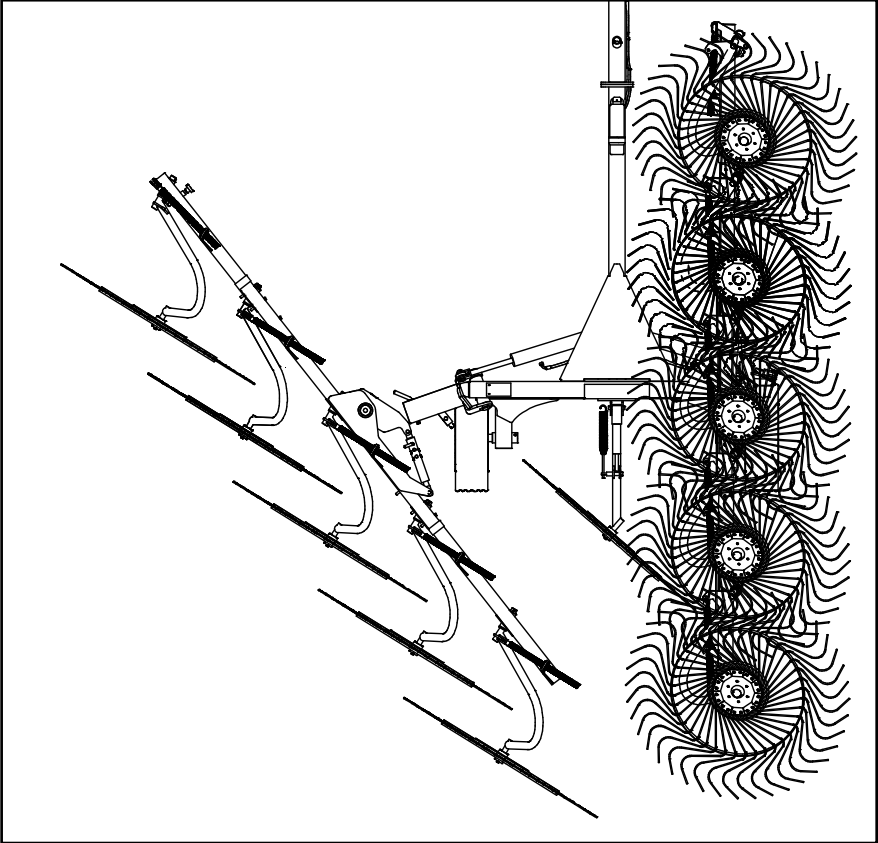

RIGHT SIDE ONLY

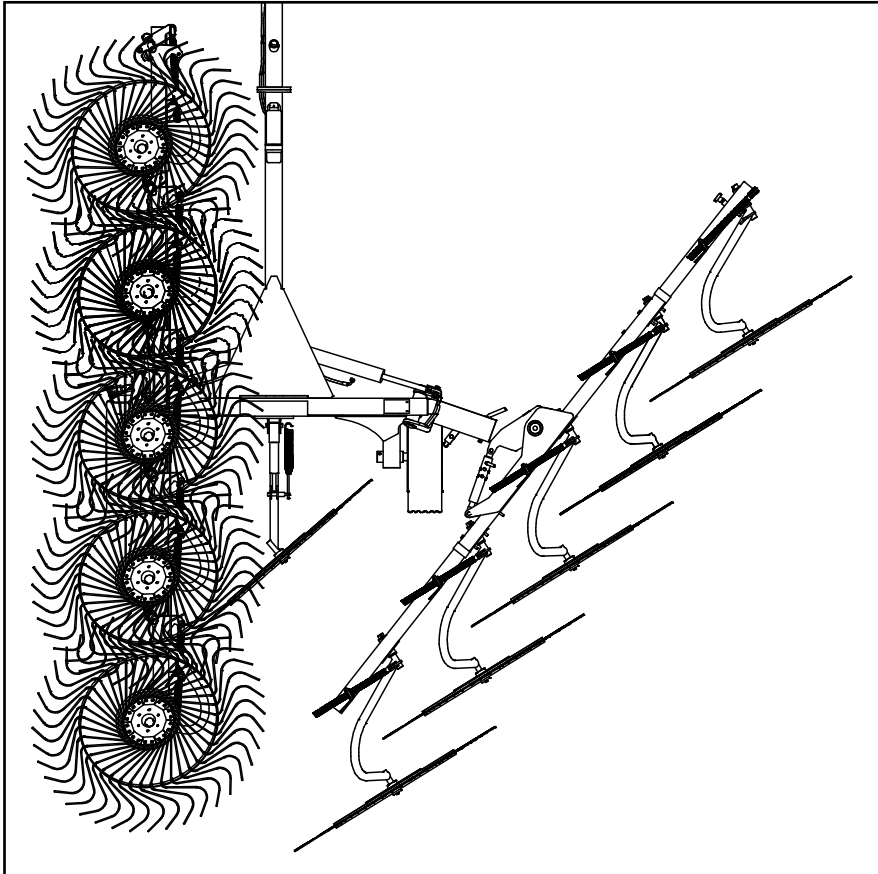

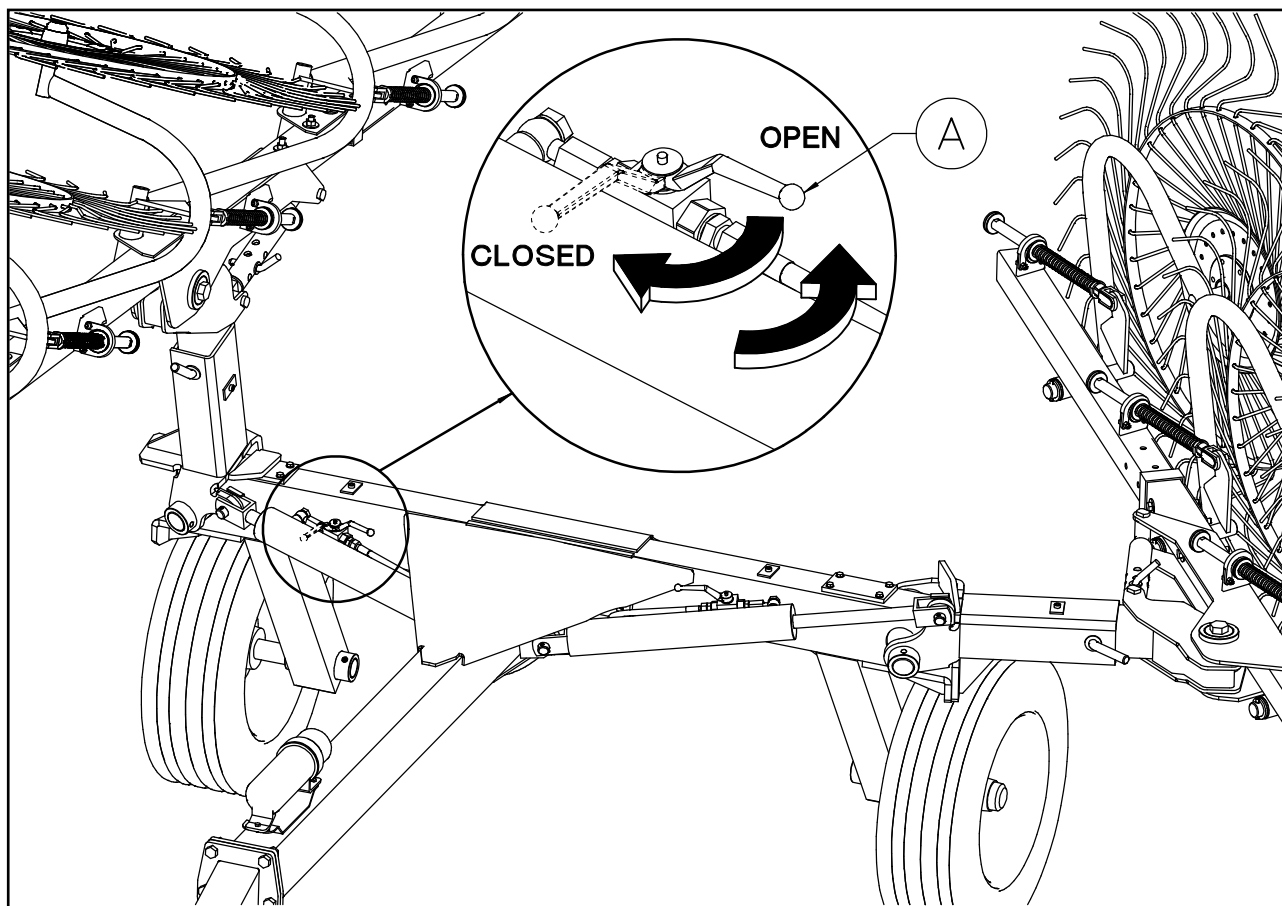

Stop the tractor engine and remove the key.

Close the cock valve (A), on the side on which you not want to work.

Get back on the tractor and lower the hay rake arm with the hydraulic cylinder.

On the side where the cylinder valve was closed, the arm will be raised.

Once the arm has gone over center, place the tractor hydraulics into the float position, allowing the rake arms to finish lowering

The machine is ready to work on one side only.

7) *General maintenance instructions*

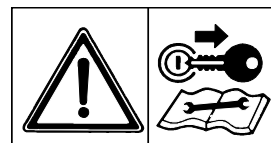
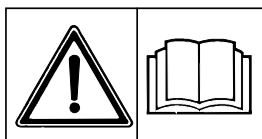
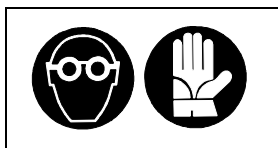

Repair work

Any repair work must be carried out with the machine at rest and disconnected from the tractor.

Do not carry out welding without authorisation and instructions from the manufacturers.

Rest the machine on the ground, release the pressure from the hydraulic circuit and leave the machine to cool down.

Repairs on elements under pressure or tension (springs, pressure accumulators, etc.) must only be carried out by competent persons with regulation equipment. Wear the appropriate protective clothing for the work in hand.

Disconnect the machine from the tractor before any welding work in order not to damage the battery. Always use a protective mask, goggles and gloves when welding, sanding or grinding or when using a hammer or drill.

Always work on the machine out of doors. If you have to operate the machine when connected to the tractor in an enclosed area (for example when testing after repair and/or maintenance), ensure that there is sufficient ventilation so as to prevent noxious exhaust gases accumulating.

In order to acquire the necessary control and to operate in safety, practise various manoeuvres by simulating those required in the workplace with the help of an experienced person.

Laying up for extended periods

At the end of the season, or when an extended period of inactivity is envisaged, it is advisable to:

- 1) clean the machine following instructions and allow it to dry;
- 2) check it carefully and replace any damaged or worn parts;
- 3) thoroughly tighten all screws and bolts;
- 4) grease the machine thoroughly and then cover it completely and lay it up in a dry place.

It is to the users advantage to carry out these operations carefully. In this way, he will have a machine in perfect condition when work is restarted.

On restarting work, repeat all the proper checks so as to be certain of working in conditions of maximum safety.

IMPORTANT

During extended periods of inactivity.

The rods parts remaining outside the cylinder pipe must be carefully protected with a grease layer.

Maintenance direction

All cleaning, lubrication and maintenance operations must be carried out with the machine disconnected from the tractor.

In an emergency with the machine still connected to the tractor, switch off the engine, apply the parking brake, and remove the ignition key from the instrument panel.

Regular, correct maintenance and proper operation are the basic prerequisites for the long-term efficiency and safe operation of the machine.

Pay special attention to all instructions given on signs located on the machine.

All maintenance should be carried out in an area having the proper equipment readily available and in good condition. This area must always be kept clean and dry and must have enough surrounding space to facilitate operations.

Any work must be carried out by trained personnel. Contact the dealer nearest to you.

Respect the warnings and procedure for maintenance and technical assistance given in this manual.

Do not use petrol, solvents or other flammable liquids as detergents.

Use commercial non-flammable and non-toxic solvents, authorised by competent bodies.

Do not use compressed air or water at high pressure to clean the machine. If this is unavoidable, then wear goggles with side protection and limit the pressure as much as possible. When the work is finished, and with the machine disconnected from the tractor, inspect and check the machine completely.

After the first 10 hours of use

Check tightness of all bolt and nuts, particularly on wheels

Tires

Regularly check the tire pressure. Respect manufacturer's recommendations on tire pressure. Assembly, disassembly and repair of wheels and tires must only be carried out by competent persons

Hydraulic circuit

Beware! The hydraulic circuit is under pressure. Maximum pressure at work: 3000 psi (200 bar).

Before connecting hoses to the tractor hydraulics, ensure that tractor and machine circuits are not under pressure. Before disconnecting a hose, depressurize the hydraulic circuit.

To avoid making wrong connections, mark hydraulic couplers and corresponding hoses with colors.

WARNING! Functions could be reversed (for example: lift/lower) and cause accidents.

Regularly check the hydraulic hoses. In case of normal wear, replace the hydraulic hoses every 5 years. Damaged or worn hoses must immediately be replaced. When replacing the hydraulic hoses, make sure to use hoses with the specifications and quality recommended by the manufacturer of the machine.

To locate a leak, use appropriate means. Protect body and hands from liquid under pressure. Use paper or cardboard to check for leaks. Never use your hand. If oil penetrates skin, gangrene or other serious injury could occur. Get immediate medical attention.

Any liquid under pressure (particularly oil from hydraulics) can penetrate the skin and cause severe injury. If injured, see a doctor immediately, there could be danger of infection.

Before any adjustments, maintenance or repairs are carried out, lower the machine on the ground, depressurize the hydraulics, turn off the engine, remove ignition key and wait until all moving parts have come to a complete stop.

SPARE PARTS LIST

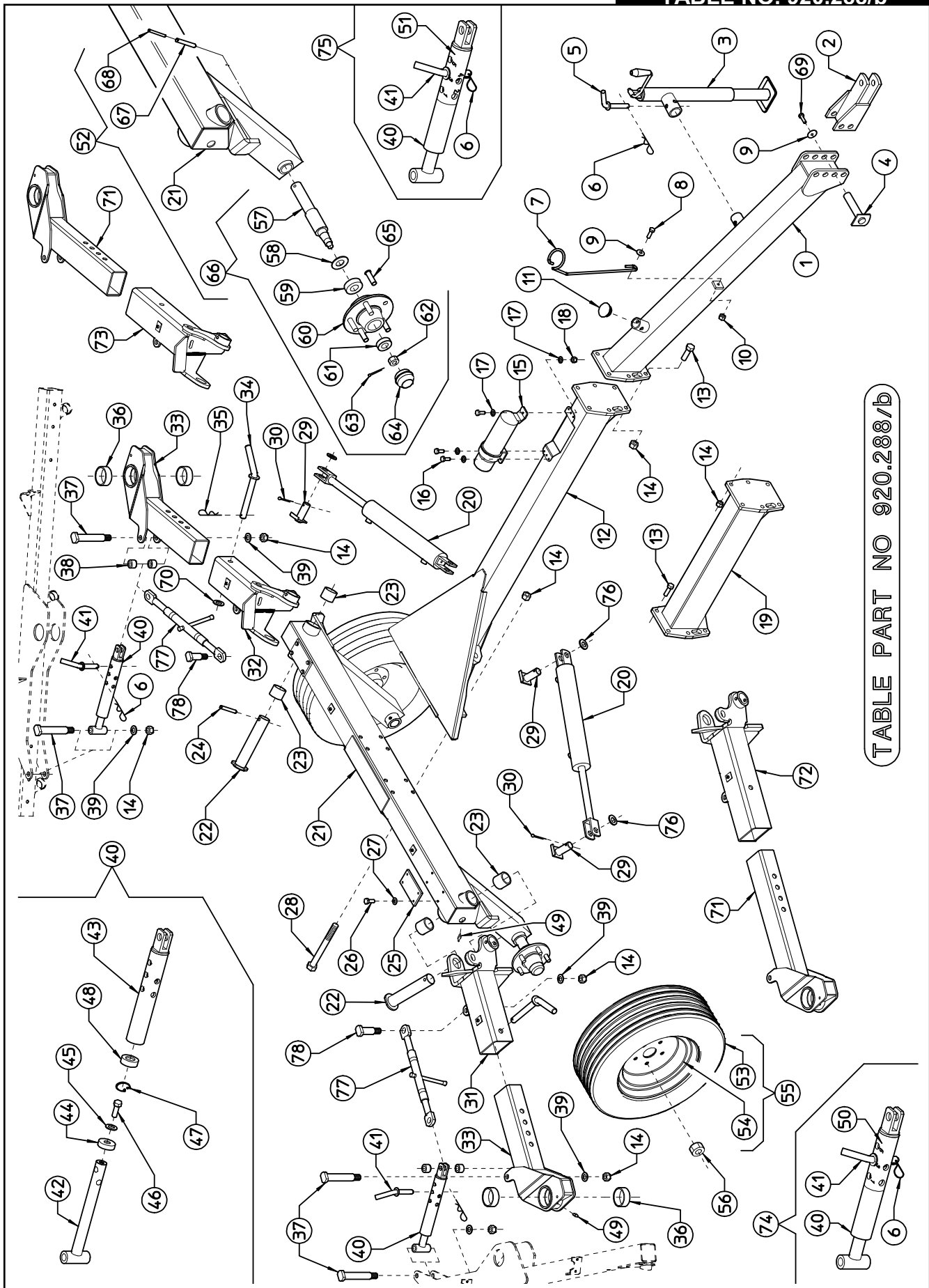

TABLE PART NO 920.288/b

TABLE PART NO 920.288/b						
ITEM	Q.ty QR/8	Q.ty QR/10	Q.ty QR/12	PART NO	DESCRIPTION	NOTE
1	1	1	1	230.787	DRAWBAR	
2	1	1	1	230.370	BRACKET	
3	1	1	1	220.197	PARKING STAND	
4	2	2	2	200.828	PIN	
5	1	1	1	200.222	PIN	
6	3	3	3	600.019	SPLIT PIN ϕ 3	
7	1	1	1	110.105	SUPPORT	
8	1	1	1	600.616	SCREW M12x35 DIN 933 8.8	
9	3	3	3	600.092	WASHER ϕ 12x36	
10	1	1	1	600.077	NUT M12 DIN 980	
11	1	1	1	610.790	PLUG	
12	1	1	1	230.679	DRAWBAR	
13	6	6	12	600.176	SCREW M16x50 DIN 931 8.8	
14	20	20	26	600.080	NUT M16 DIN 980	
15	1	1	1	230.457	CANISTER	
16	3	3	3	630.003	SCREW M6x20 DIN 933	
17	6	6	6	600.135	WASHER ϕ 6,6-18x2 UNI 6593	
18	3	3	3	600.472	NUT M6 DIN 980	
19	*	*	1	230.367	DRAWBAR	Qr 12 only
20	2	2	2	230.717	CYLINDER	
21	1	1	1	230.675	CART FRAME	
22	2	2	2	230.319	PIN	
23	4	4	4	200.199	BUSH	
24	2	2	2	600.656	SPRING PIN ϕ 12x70 DIN 1481	
25	2	2	2	230.506	BLOCK	
26	8	8	8	600.223	SCREW M8x20 DIN 933 8.8	
27	8	8	8	610.185	WASHER ϕ 9-21x2 UNI 6593	
28	8	8	8	600.595	SCREW M16x140 DIN 931 8.8	
29	4	4	4	230.368	PIN	
30	4	4	4	600.038	SPLIT PIN D6x35 DIN 94 3.6	
31	1	1	*	230.686	RH ARM	Qr 8-10 only
32	1	1	*	230.687	LH ARM	Qr 8-10 only
33	2	2	*	230.684	ARM	Qr 8-10 only
34	2	2	2	230.714	PIN	
35	2	2	2	600.308	SPLIT PIN ϕ 4	
36	4	4	4	230.666	BUSH	
37	4	4	4	230.669	PIN	
38	4	4	4	230.377	BUSH	
39	6	6	6	600.031	WASHER ϕ 17 UNI 6592	
40	2	2	2	230.725	TIE ROD, ASSY	

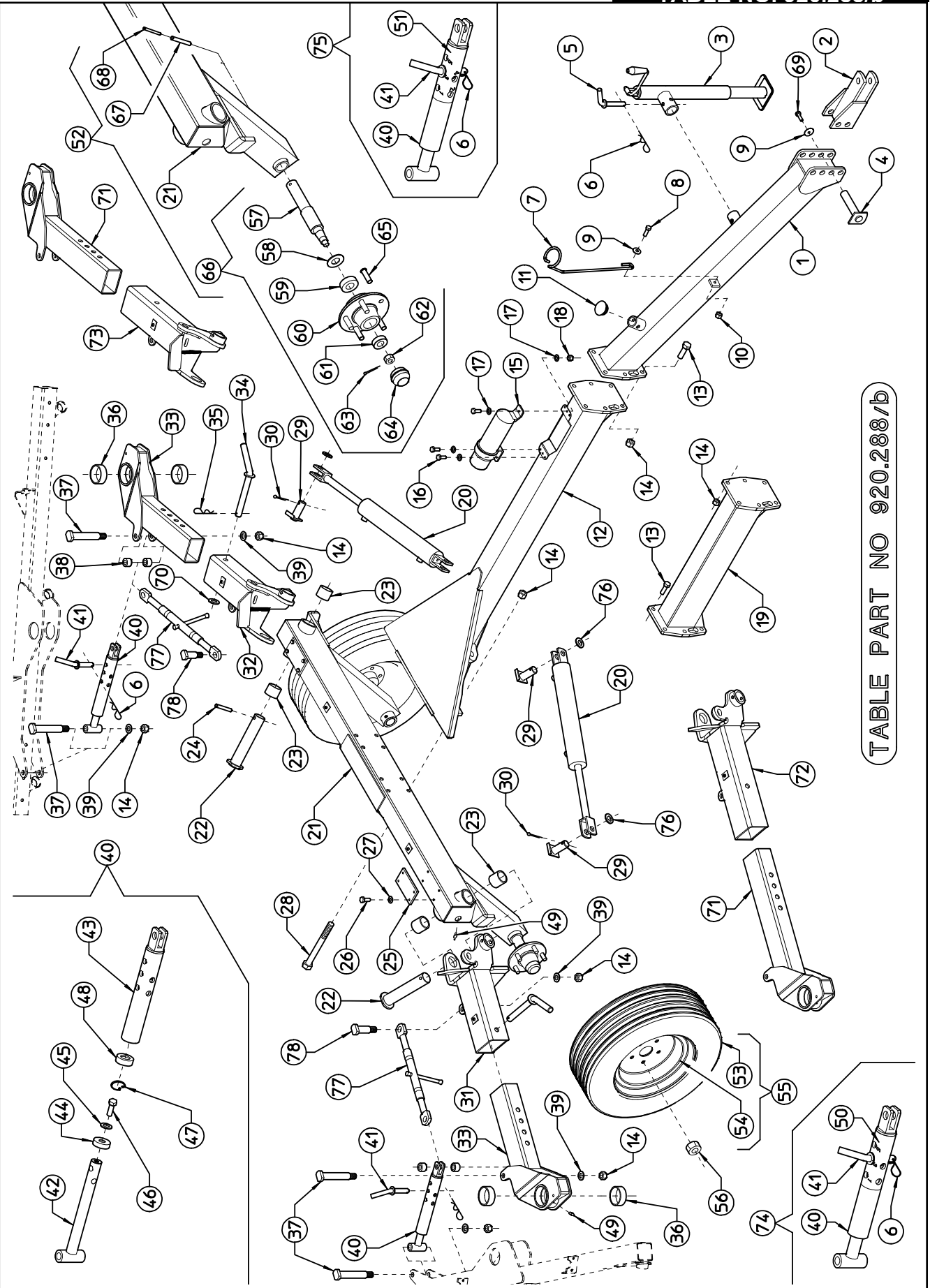

TABLE PART NO 920.288/b

TABLE PART NO 920.288/b						
ITEM	Q.ty QR/8	Q.ty QR/10	Q.ty QR/12	PART NO	DESCRIPTION	NOTE
41	2	2	2	230.715	PIN	
42	2	2	2	230.720	ROD	
43	2	2	2	230.719	BARREL	
44	2	2	2	230.721	WASHER ø11-40x10	
45	2	2	2	600.024	SPRING WASHER ø10,5 DIN 125A	
46	2	2	2	600.227	SCREW M10x20 DIN 933 8.8	
47	2	2	2	600.885	SNAP RING I42 DIN 472	
48	2	2	2	230.722	BUSH	
49	4	4	4	600.034	GREASE NIPPLE M8	
50	1	1	1	001.628	LABEL DX	
51	1	1	1	001.629	LABEL SX	
52	1	1	1	230.814	CART FRAME WITH HUBS	
53	2	2	2	600.303	TIRE	
54	2	2	2	600.304	RIM	
55	2	2	2	600.281	TIRE ASSY	
56	10	10	10	600.289	NUT M16x1,5	
57	2	2	2	225.839	HUB PIN	
58	2	2	2	600.284	DUST COVER	
59	2	2	2	600.285	BEARING 30208	
60	2	2	2	600.286	HUB	
61	2	2	2	600.287	BEARING 30206	
62	2	2	2	600.288	NUT M27x1,5	
63	2	2	2	600.291	SPLIT PIN ø4x40 DIN 94 3.6	
64	2	2	2	600.290	CAP	
65	10	10	10	610.413	SCREW M16x1,5	
66	2	2	2	230.431	HUB ASSY	
67	2	2	2	610.788	SPRING PIN ø12x60 DIN 1481	
68	2	2	2	620.326	SPRING PIN ø7x60 DIN 1481	
69	2	2	2	600.770	SCREW M12x20 DIN 933 8.8	
70	2	2	2	600.632	WASHER ø21 UNI 6592	
71	*	*	2	230.685	ARM	Qr 12 only
72	*	*	1	230.811	RH ARM	Qr 12 only
73	*	*	1	230.812	LH ARM	Qr 12 only
74	1	1	1	230.733	TIE ROD DX, ASSY WITH LABEL	
75	1	1	1	230.734	TIE ROD SX, ASSY WITH LABEL	
76	4	4	4	600.336	WASHER ø25	
77	2	2	2	230.823	TIE ROD	
78	2	2	2	230.713	PIN	

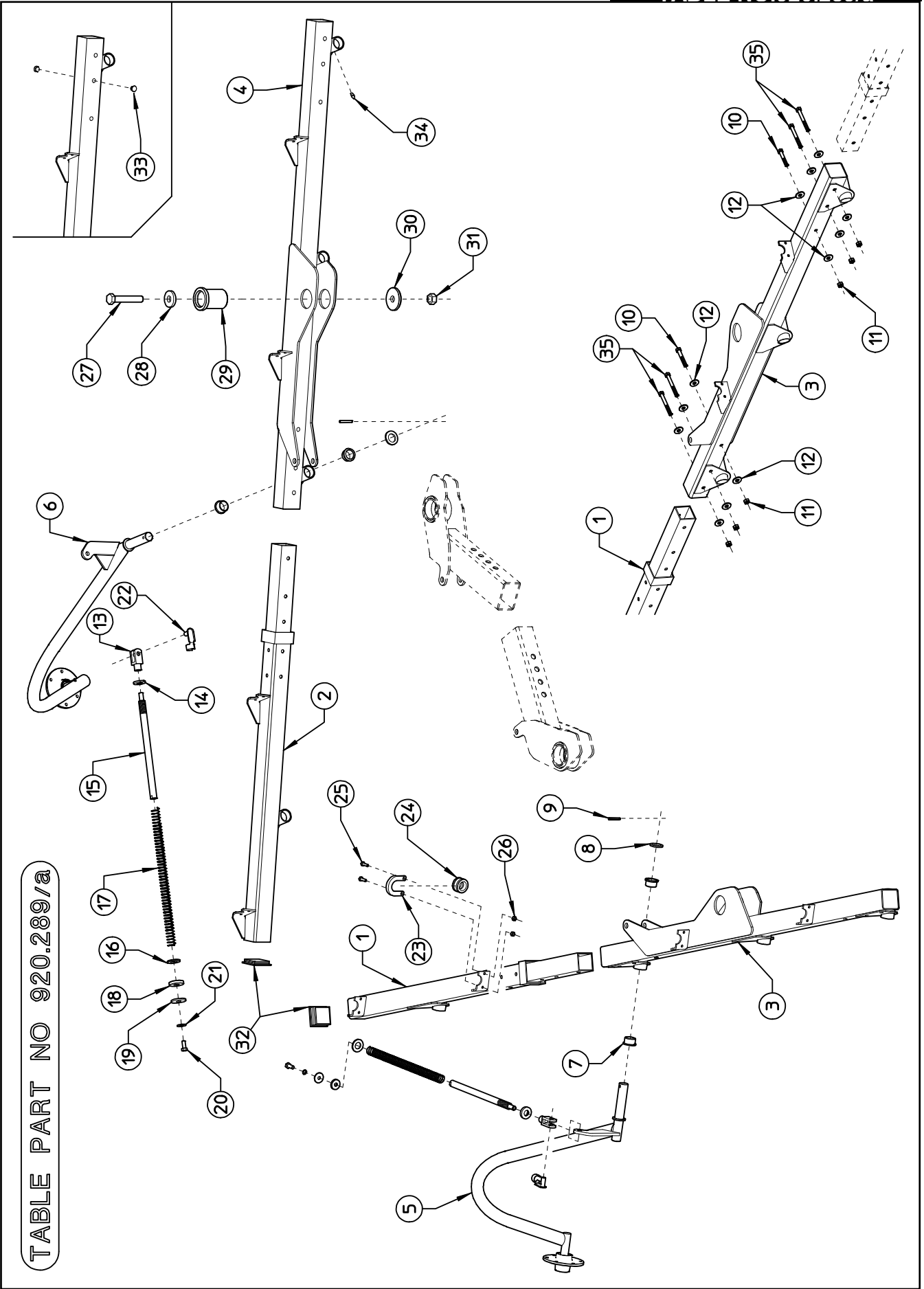

TABLE PART NO 920.289/a

TABLE PART NO 920.289/a						
ITEM	Q.ty QR/8	Q.ty QR/10	Q.ty QR/12	PART NO	DESCRIPTION	NOTE
1	1	1	1	230.710	RH EXTENSION	
2	1	1	1	230.711	LH EXTENSION	
3	1	1	*	230.671	MAIN PIPE, RH	Qr 8-10 only
3a	*	*	1	230.682	MAIN PIPE, RH	Qr 12 only
4	1	1	*	230.672	MAIN PIPE, LH	Qr 8-10 only
4a	*	*	1	230.683	MAIN PIPE, LH	Qr 12 only
5	4	4	5	230.673	WHEEL ARM, RH	
6	4	4	5	230.674	WHEEL ARM, LH	
7	16	20	24	200.029	BUSH	
8	8	10	12	200.028	WASHER $\phi 35,5-50 \times 5$	
9	8	10	12	600.027	SPRING PIN $\phi 8 \times 50$	
10	2	4	4	610.516	SCREW M12x100 DIN 931 8.8	
11	6	12	12	600.077	NUT M12 DIN 980	
12	12	24	24	600.092	WASHER $\phi 12 \times 36$	
13	8	10	12	630.375	FORK M16	
14	8	10	12	230.729	NUT M22	
15	8	10	12	230.658	ROD	
16	8	10	12	230.661	WASHER $\phi 26-55 \times 5$	
17	8	10	12	230.663	SPRING	
18	8	10	12	230.662	WASHER $\phi 23-50 \times 8$	
19	8	10	12	230.709	WASHER $\phi 13-50 \times 4$	
20	8	10	12	600.441	SCREW M12x25 DIN 933 8.8	
21	8	10	12	600.018	SPRING WASHER $\phi 13$ DIN 125A	
22	8	10	12	630.586	PIN	
23	8	10	12	230.664	SUPPORT	
24	8	10	12	230.659	BUSH	
25	16	20	24	600.702	SCREW M8x25 DIN 933 8.8	
26	16	20	24	600.076	NUT M8 DIN 980	
27	2	2	2	630.560	SCREW M24x150 DIN 931 8.8	
28	2	2	2	230.668	WASHER $\phi 25-64 \times 10$	
29	2	2	2	230.665	PIN	
30	2	2	2	230.667	WASHER $\phi 25-90 \times 10$	
31	2	2	2	620.255	NUT M24 DIN 980	
32	4	4	4	630.079	PLUG	
33	12	*	*	620.816	PLUG	Qr 8 only
34	8	10	12	600.124	GREASE NIPPLE M6	
35	4	8	8	600.156	SCREW M12x110 DIN 931 8.8	

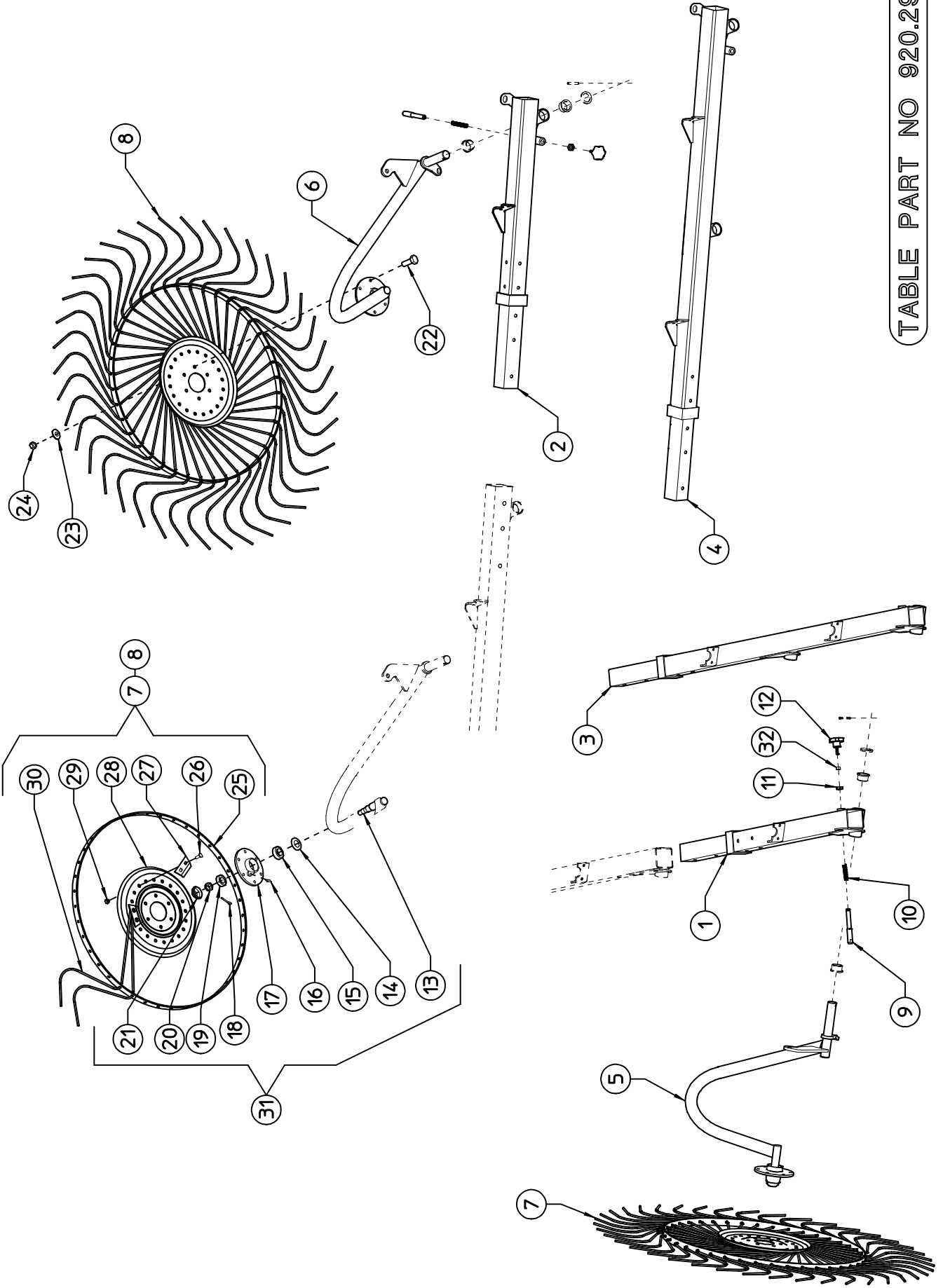
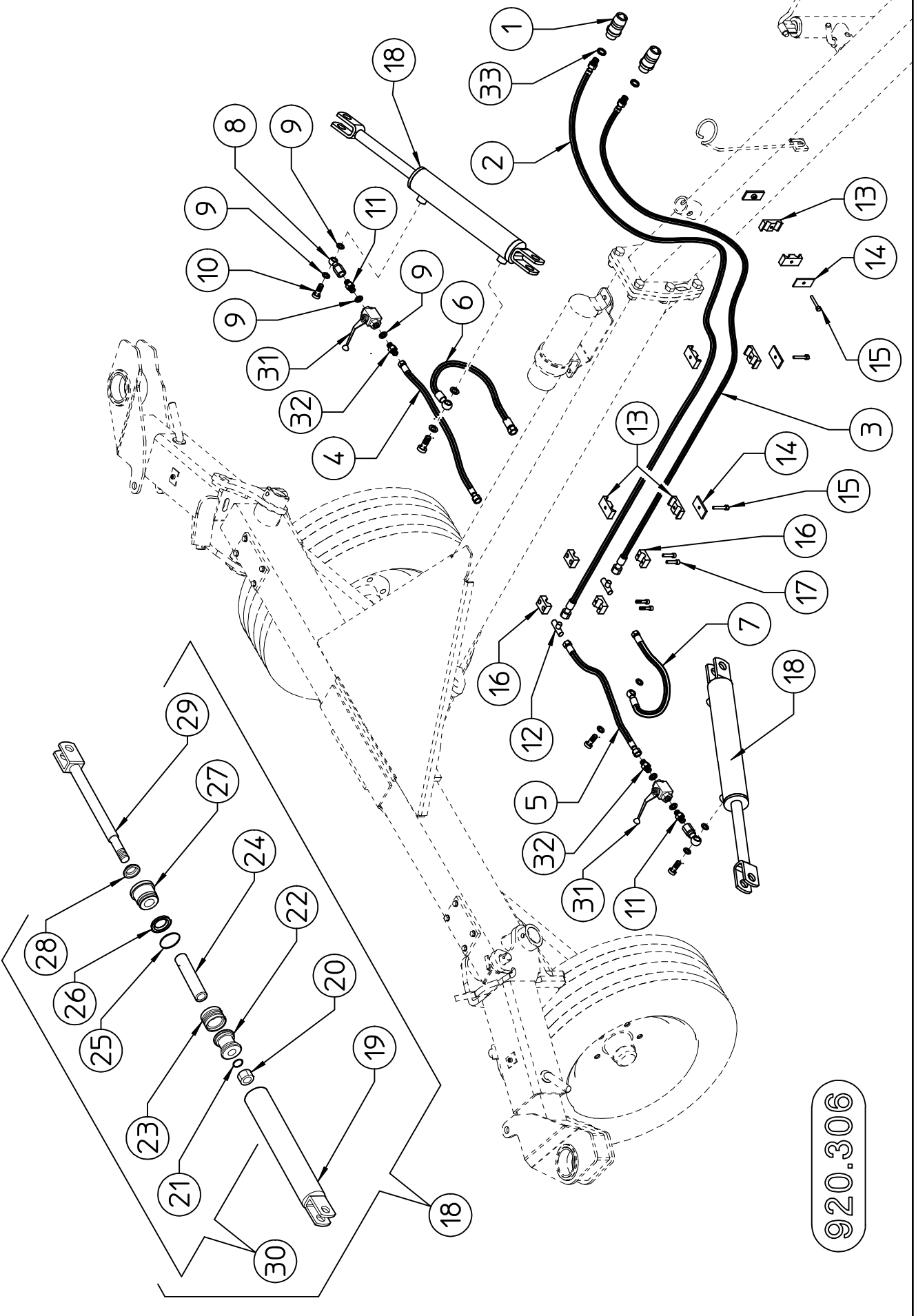
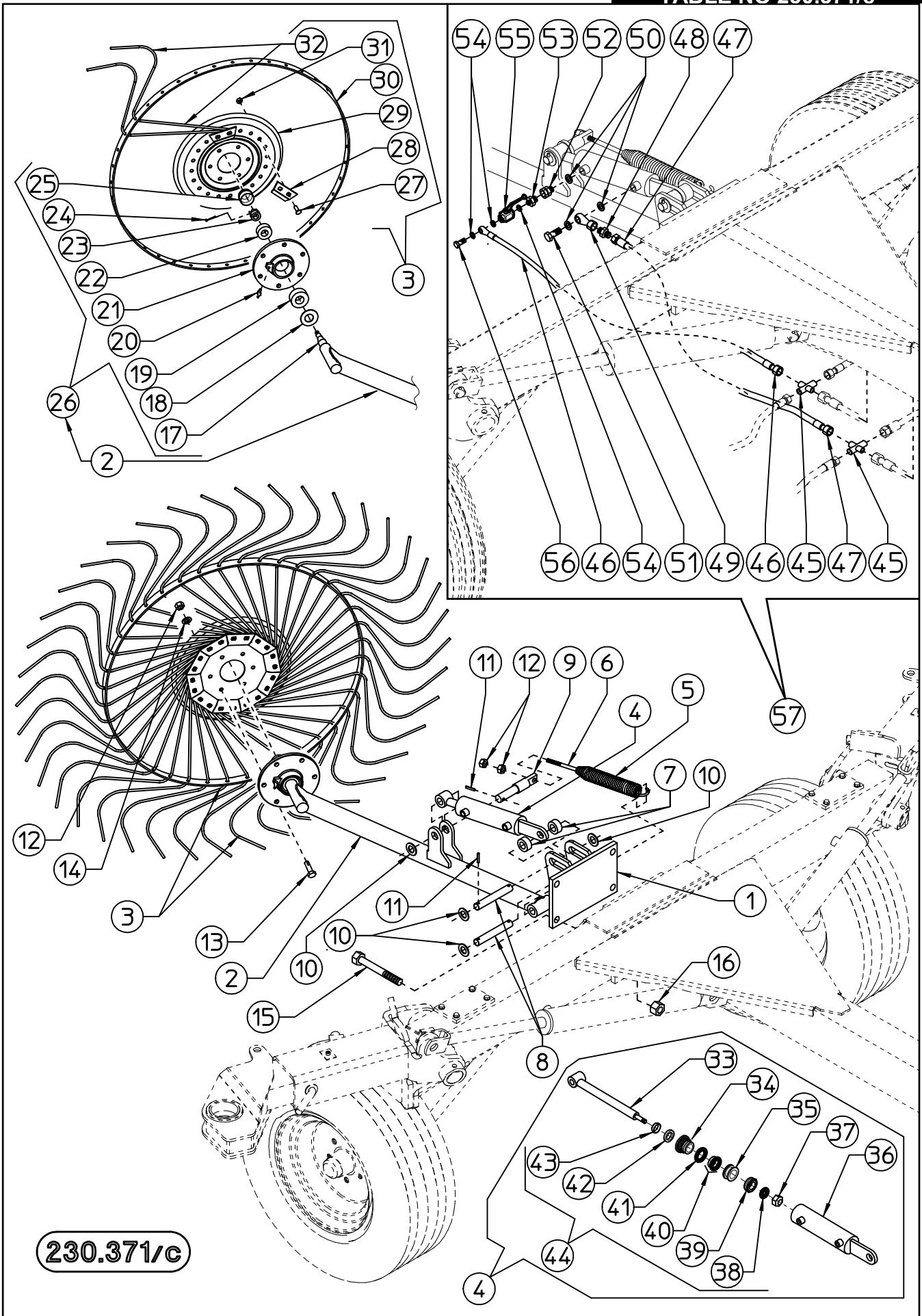

TABLE PART NO 920.290						
ITEM	Q.ty QR/8	Q.ty QR/10	Q.ty QR/12	PART NO	DESCRIPTION	NOTE
1	*	1	*	230.677	RH EXSTENSION	Qr-10 only
2	*	1	*	230.678	LH EXSTENSION	Qr-10 only
3	*	*	1	230.680	RH EXSTENSION	Qr-12 only
4	*	*	1	230.681	LH EXSTENSION	Qr-12 only
5	*	1	1	230.723	WHEEL ARM, RH	
6	*	1	1	230.724	WHEEL ARM, LH	
7	4	5	6	210.180	WHEEL ASSY, RH	
8	4	5	6	210.181	WHEEL ASSY, LH	
9	*	2	2	230.712	PIN	
10	*	2	2	230.716	SPRING	
11	*	2	2	600.082	NUT M16 DIN 936	
12	*	2	2	630.571	KNOB	
13	8	10	12	205.277	PIN	
14	8	10	12	600.011	DUST COVER	
15	8	10	12	600.012	BEARING 30205	
16	8	10	12	600.034	GREASE NIPPLE M8	
17	8	10	12	600.013	WHEEL HUB	
18	8	10	12	600.301	SPLIT PIN ø3x30 DIN 94	
19	8	10	12	600.014	BEARING 30204	
20	8	10	12	600.015	SELF-LOCKING NUT M18x1,5	
21	8	10	12	600.016	SAFETY CAP	
22	48	60	72	600.006	SCREW M10x25 DIN 933 8.8	
23	48	60	72	600.024	SPRING WASHER ø10,5 similar to DIN 127B	
24	48	60	72	600.010	NUT M10 DIN 934-8	
25	8	10	12	200.009	RIM	
26	160	200	240	600.005	SCREW M10x25 DIN 603	
27	80	100	120	200.012	TINE CLAMP	
28	8	10	12	200.010	FLANGE	
29	160	200	240	600.029	NUT M10 DIN 980	
30	320	400	480	210.621	TINE DIA 0,276" (7mm)	
31	8	10	12	205.041	HUB ASSY	
32	*	2	2	600.037	NUT M8 DIN 934	



920.306

TABLE PART NO 920.306				
ITEM	Q.ty	PART NO	DESCRIPTION	NOTE
1	2	600.273	RAPID COUPLING 1/2"	
2	1	630.621	HOSE SAE100 R2AT 1/4" L 4300 FD-MD	For Qr/8-10
2	1	630.625	HOSE SAE100 R2AT 1/4" L 5100 FD-MD	For Qr/12
3	1	630.622	HOSE SAE100 R2AT 1/4" L 4150 FD-MD	For Qr/8-10
3	1	630.626	HOSE SAE100 R2AT 1/4" L 4950 FD-MD	For Qr/12
4	1	630.689	HOSE SAE100 R2AT 1/4" L 420 FD-FD	
5	1	630.690	HOSE SAE100 R2AT 1/4" L 540 FD-FD	
6	1	630.623	HOSE SAE100 R2AT 1/4" L 475 FD-OC	
7	1	630.624	HOSE SAE100 R2AT 1/4" L 420 FD-OC	
8	2	630.315	TURNING FITTING FD-OC	
9	12	620.452	COPPER WASHER 3/8"	
10	4	600.040	FITTING SCREW	
11	2	200.192	NIPPLE 3/8" - 3/8" 0,8	
12	2	600.823	FITTING M-M-M 1/4"	
13	6	630.457	HOSE COLLAR ø16	
14	3	610.164	PLATE	
15	3	610.165	SCREW M8x35 DIN 931	
16	4	610.035	HOSE COLLAR	
17	4	610.037	SCREW M6x25 TCEI	
18	2	230.717	CYLINDER	
19	2	230.727	CYLINDER BARREL	
20	1*	600.879	NUT	*For one cylinder
21	1*	600.983	GASKET	*For one cylinder
22	2	210.227	PISTON	
23	1*	600.984	GASKET	*For one cylinder
24	2	230.726	SPACER	
25	1*	600.982	GASKET	*For one cylinder
26	1*	610.031	GASKET	*For one cylinder
27	2	210.569	CYLINDER HEAD	
28	1*	600.645	GASKET	*For one cylinder
29	2	230.728	ROD	
30	1*	610.340	SET OF GASKET	*For one cylinder
31	2	610.002	VALVE	
32	2	600.270	NIPPLE 3/8" - 3/8"	
33	2	630.048	COPPER WASHER 1/2"	



230.371/c

WHEEL CENTRAL KIT 230.371/c				
ITEM	Q.ty	PART NO	DESCRIPTION	NOTE
1	1	230.306	SUPPORT	
2	1	230.374	ARM	
3	1	200.802	WHEEL ASSY L.H. (TINE DIA 0,276" 7mm)	
4	1	230.375	CYLINDER	
5	1	230.376	SPRING	
6	1	210.173	TIE ROD	
7	2	230.377	SPACER	
8	2	230.378	PIN	
9	1	230.379	PIN	
10	5	600.632	WASHER ø21 DIN 125A	
11	5	600.538	SPING PIN ø6x35 DIN 1481	
12	8	600.010	NUT M10 DIN 934	
13	6	600.006	SCREW M10 x 25 DIN 933	
14	6	600.024	SPRING WASHER D 10,5 similar to DIN 127B	
15	4	600.219	SCREW M16x150 DIN 931	
16	4	600.080	NUT M16 DIN 980	
17	1	205.819	PIN	
18	1	600.011	DUST COVER	
19	1	600.012	BEARING 30205	
20	1	600.034	GREASE NIPPLE M8	
21	1	600.013	WHEEL HUB	
22	1	600.014	BEARING 30204	
23	1	600.015	SELF-LOCKING NUT M18x1,5	
24	1	600.301	SPLIT PIN ø3x30 DIN 94	
25	1	600.016	SAFETY CAP	
26	1	205.777	HUB ASSY	
27	20	600.005	SCREW M10x25 DIN 603	
28	10	200.012	TINE CLAMP	
29	1	200.010	FLANGE	
30	1	200.840	RIM	
31	20	600.029	NUT M10 DIN 980	
32	40	200.841	TINE DIA 0,276" (7mm)	
33	1	230.400	ROD ø20	
34	1	230.398	HEAD ø40/20	
35	1	230.397	PISTON ø40	
36	1	230.399	CYLINDER BARREL ø40/50	
37	1	600.121	NUT M18x1,5 DIN 985	
38	1	630.322	GASKET OR ø12,34x2,62	
39	1	610.028	GASKET DBM 157118	
40	1	630.321	GASKET OR ø36,14x2,62 + BK	
41	1	630.323	GASKET OR ø39,34x2,62	
42	1	630.324	GASKET ø20/28x5,8	
43	1	610.025	GASKET WRM 078110	
44	1	630.325	SET OF GASKET	
45	2	620.978	FITTING 1/4"	
46	1	630.632	HOSE SAE 100R2AT x1/4" L.730-28,74"	
47	1	630.631	HOSE SAE 100R2AT x1/4" L.640-25,20"	
48	1	200.192	NIPPLE 3/8"-3/8" WITH ORIFICE 0,8	
49	1	630.315	FITTING 3/8"	
50	3	620.452	COPPER WASHER 3/8"	
51	1	600.040	FITTING 3/8"	
52	1	600.271	FITTING 3/8" MALE-3/8" FEMALE	
53	1	600.883	NIPPLE 1/4"-3/8"	
54	3	630.376	COPPER WASHER 1/4"	
55	1	620.492	VALVE 1/4" 170 bar	
56	1	600.820	FITTING 1/4"	
57	1	230.344/d	HYDRAULIC KIT	

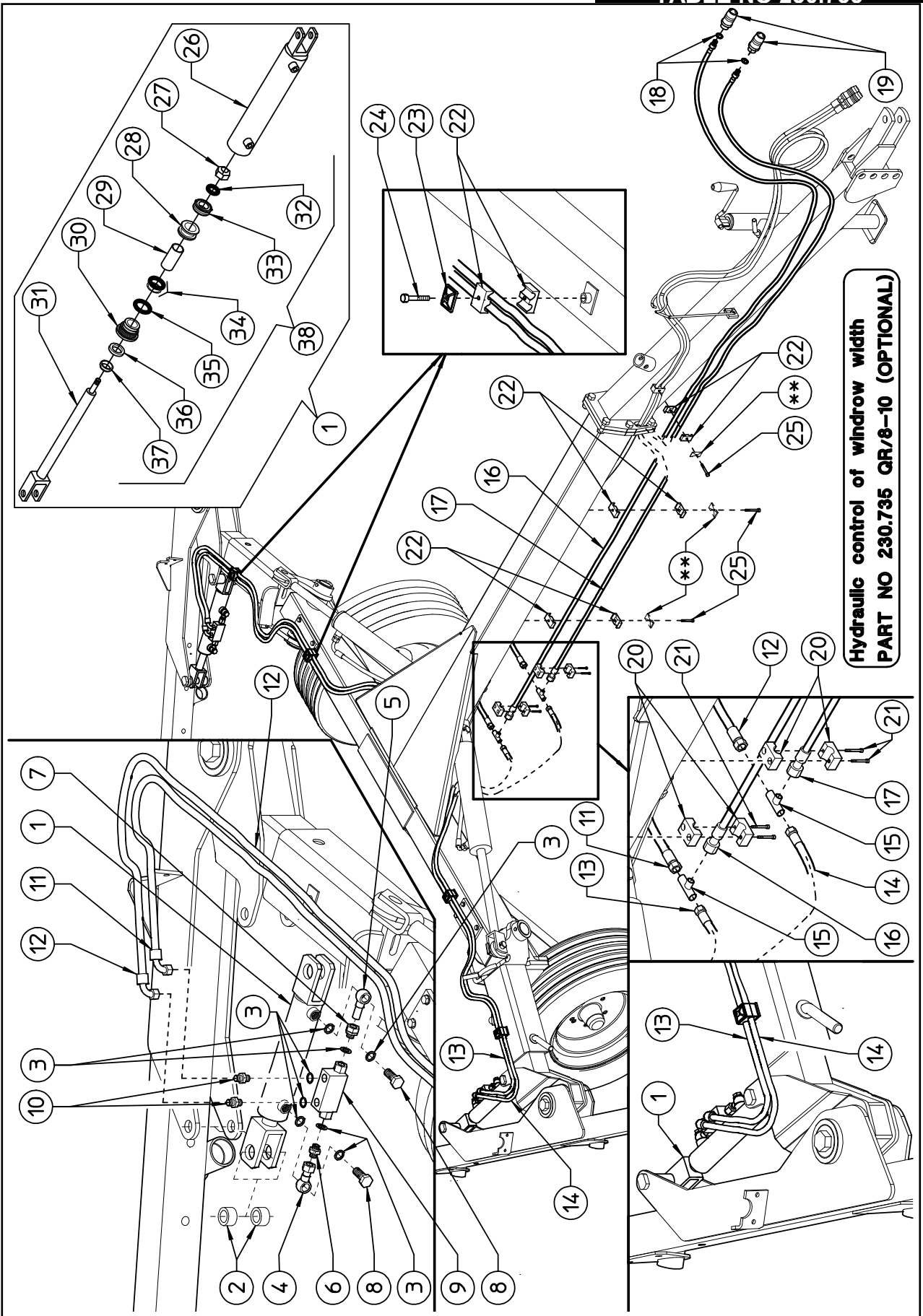

HYDRAULIC CONTROL OF WINDROW WIDTH QR/8-10 - PART NO 230.735 (OPTIONAL)				
ITEM	Q.ty	PART NO	DESCRIPTION	NOTE
1	2	230.383	CYLINDER	
2	4	230.377	BUSH	
3	16	630.376	COPPER WASHER ϕ 1/4"	
4	2	630.332	FITTING 1/4"	
5	2	230.412	TUBE	
6	2	630.331	NIPPLE 1/4"-1/4" WITH ORIFICE 0,6	
7	2	630.334	FITTING MALE 1/4" FEMALE ϕ 12	
8	4	600.820	FITTING 1/4"	
9	2	630.333	LOCK VALVE 1/4"	
10	4	630.320	NIPPLE 1/4"-1/4"	
11	1	630.629	HOSE R2 AT 1/4" LENGHT 1900mm-74,80"	
12	1	630.630	HOSE R2 AT 1/4" LENGHT 2150mm-84,65"	
13	1	630.627	HOSE R2 AT 1/4" LENGHT 2000mm-78,74"	
14	1	630.628	HOSE R2 AT 1/4" LENGHT 2050mm-80,71"	
15	2	600.823	FITTING MALE 1/4"	
16	1	630.621	HOSE R2 AT 1/4" LENGHT 4300mm-169,29"	
17	1	630.622	HOSE R2 AT 1/4" LENGHT 4150mm-163,38"	
18	2	630.048	COPPER WASHER ϕ 1/2"	
19	2	600.273	RAPID COUPLING 1/2"	
20	4	610.035	HOSE COLLAR	
21	4	610.901	SCREW M6x60 DIN 912	
22	14	630.457	DOUBLE HOSE COLLAR	
23	4	610.164	COLLAR CLAMP	
24	4	610.165	SCREW M8x35 DIN 931	
25	3	610.525	SCREW M8x60 DIN 931	
26	2	230.409	CYLINDER BARREL ϕ 40/50	
27	2	600.121	NUT M18x1,5 DIN 985	
28	2	230.397	PISTON ϕ 40	
29	2	230.411	SPACER	
30	2	230.398	HEAD ϕ 40/20	
31	2	230.410	ROD ϕ 20	
32	2	630.322	GASKET OR ϕ 12,34x2,62	
33	2	610.028	GASKET DBM 157118	
34	2	630.321	GASKET OR ϕ 36,14x2,62 + BK	
35	2	630.323	GASKET OR ϕ 39,34x2,62	
36	2	630.324	GASKET ϕ 20/28x5,8	
37	2	610.025	GASKET WRM 078110	
38	2	630.325	SET OF GASKET	
**	USE THE PIECES ALL READY FITTED ON THE MACHINE			

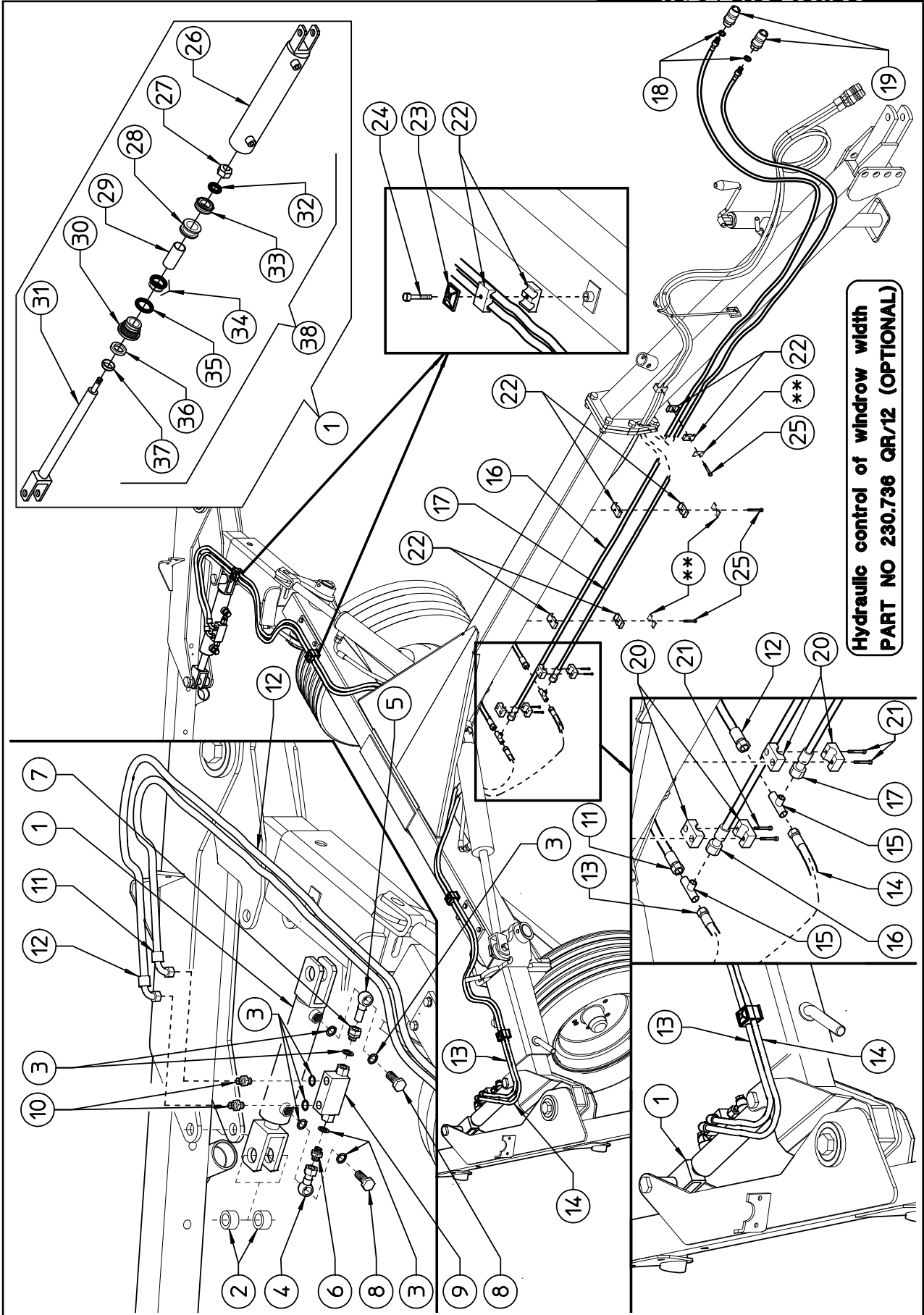

Hydraulic control of windrow width
PART NO 230.736 GR/12 (OPTIONAL)

HYDRAULIC CONTROL OF WINDROW WIDTH QR/12 - PART NO 230.736 (OPTIONAL)				
ITEM	Q.ty	PART NO	DESCRIPTION	NOTE
1	2	230.383	CYLINDER	
2	4	230.377	BUSH	
3	16	630.376	COPPER WASHER ø1/4"	
4	2	630.332	FITTING 1/4"	
5	2	230.412	TUBE	
6	2	630.331	NIPPLE 1/4"-1/4" WITH ORIFICE 0,6	
7	2	630.334	FITTING MALE 1/4" FEMALE ø12	
8	4	600.820	FITTING 1/4"	
9	2	630.333	LOCK VALVE 1/4"	
10	4	630.320	NIPPLE 1/4"-1/4"	
11	1	630.629	HOSE R2 AT 1/4" LENGHT 1900mm-74,80"	
12	1	630.630	HOSE R2 AT 1/4" LENGHT 2150mm-84,65"	
13	1	630.627	HOSE R2 AT 1/4" LENGHT 2000mm-78,74"	
14	1	630.628	HOSE R2 AT 1/4" LENGHT 2050mm-80,71"	
15	2	600.823	FITTING MALE 1/4"	
16	1	630.625	HOSE R2 AT 1/4" LENGHT 5100mm-200,78"	
17	1	630.626	HOSE R2 AT 1/4" LENGHT 4950mm-194,88"	
18	2	630.048	COPPER WASHER ø1/2"	
19	2	600.273	RAPID COUPLING 1/2"	
20	4	610.035	HOSE COLLAR	
21	4	610.901	SCREW M6x60 DIN 912	
22	14	630.457	DOUBLE HOSE COLLAR	
23	4	610.164	COLLAR CLAMP	
24	4	610.165	SCREW M8x35 DIN 931	
25	3	610.525	SCREW M6x60 DIN 931	
26	2	230.409	CYLINDER BARREL ø40/50	
27	2	600.121	NUT M18x1,5 DIN 985	
28	2	230.397	PISTON ø40	
29	2	230.411	SPACER	
30	2	230.398	HEAD ø40/20	
31	2	230.410	ROD ø20	
32	2	630.322	GASKET OR ø12,34x2,62	
33	2	610.028	GASKET DBM 157118	
34	2	630.321	GASKET OR ø36,14x2,62 + BK	
35	2	630.323	GASKET OR ø39,34x2,62	
36	2	630.324	GASKET ø20/28x5,8	
37	2	610.025	GASKET WRM 078110	
38	2	630.325	SET OF GASKET	
**	USE THE PIECES ALL READY FITTED ON THE MACHINE			

CONVERSION KIT QR/8 INTO QR/10 PART NO 230.844

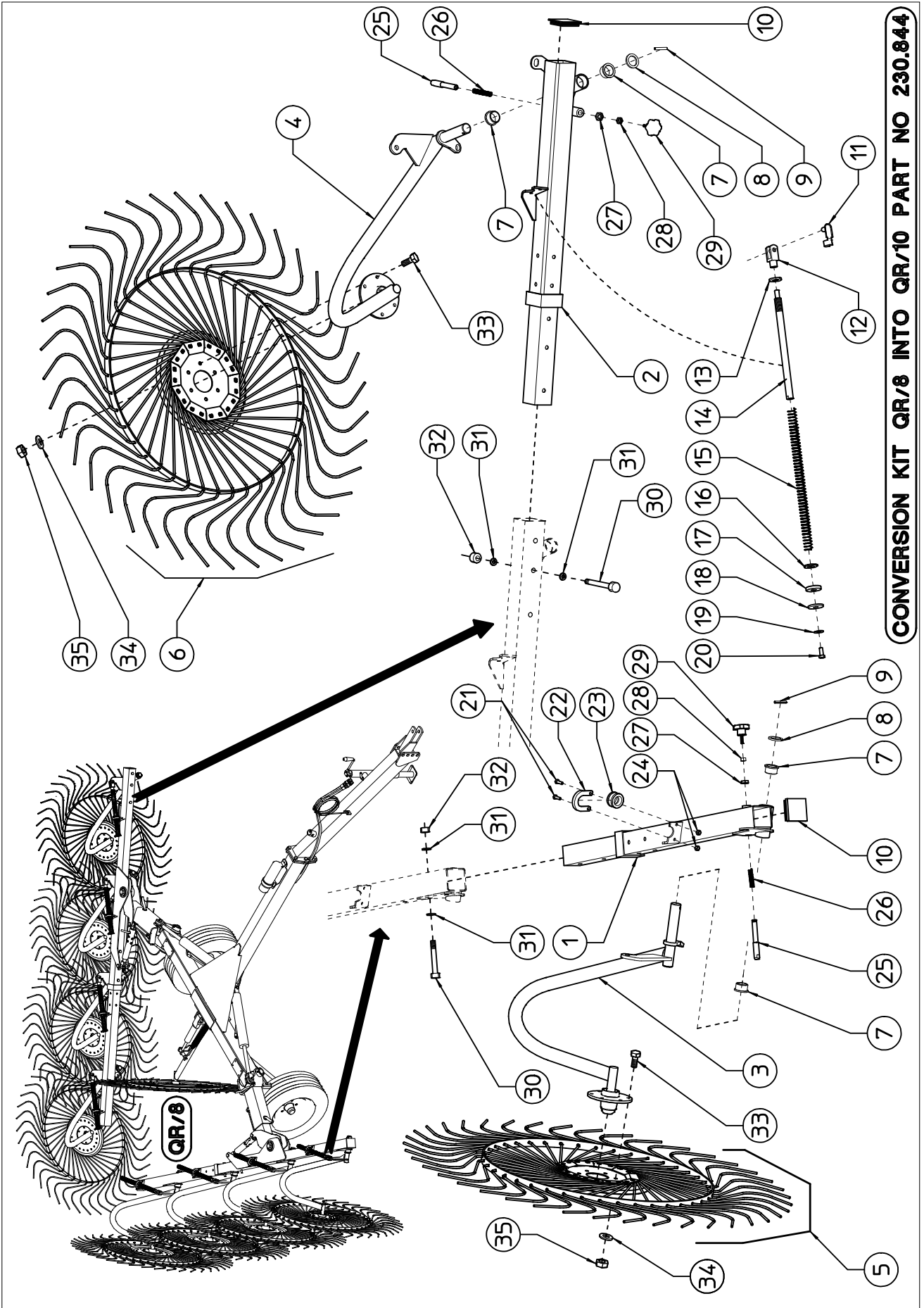

CONVERSION KIT QR/8 INTO QR/10 PART NO 230.844

CONVERSION KIT QR/8 INTO QR/10 - PART NO 230.844				
ITEM	Q.ty	PART NO	DESCRIPTION	NOTE
1	1	230.677	RH EXTENSION	
2	1	230.678	LH EXTENSION	
3	1	230.723	RH ARM	
4	1	230.724	LH ARM	
5	1	210.180	RH WHEEL ASSY	
6	1	210.181	LH WHEEL ASSY	
7	4	200.029	NYLON BUSH	
8	2	200.028	WASHER $\varnothing 35,5/50 \times 5$	
9	2	600.027	SPRING PIN $\varnothing 8 \times 50$	
10	2	630.079	PLUG	
11	2	630.586	PIN	
12	2	630.375	FORK M16	
13	2	230.729	NUT M22	
14	2	230.658	TIE ROD $\varnothing 25$	
15	2	230.663	SPRING	
16	2	230.661	WASHER $\varnothing 26-55 \times 5$	
17	2	230.662	WASHER $\varnothing 23-50 \times 8$	
18	2	230.709	WASHER $\varnothing 13-50 \times 4$	
19	2	600.018	SPRING WASHER $\varnothing 13$ DIN 125A	
20	2	600.441	SCREW M12x25 DIN 933 8.8	
21	4	600.702	SCREW M8x25 DIN 933 8.8	
22	2	230.664	SUPPORT	
23	2	230.659	NYLON BUSH	
24	4	600.076	NUT M8 DIN 980	
25	2	230.712	PIN	
26	2	230.716	SPRING	
27	2	600.082	NUT M16 DIN 936	
28	2	600.037	NUT M8 DIN 934	
29	2	630.571	KNOB	
30	6	610.516	SCREW M12 x 100 DIN 931 8.8	
31	12	600.092	WASHER $\varnothing 12-36$	
32	6	600.077	NUT M12 DIN 980	
33	12	600.006	SCREW M10 x 25 DIN 933 8.8	
34	12	600.024	SPRING WASHER D 10,5	
35	12	600.010	NUT M10 DIN 934	

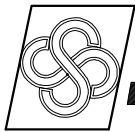

sitrex[®] AGRICULTURAL MACHINERY Spq .

Zona Industriale-Viale Grecia, 8
06018 TRESTINA-(Perugia)-ITALY
Tel. +39.075.8540021-Telefax +39.075.8540523
e-mail: sitrex@sitrex.it www.sitrex.com

