

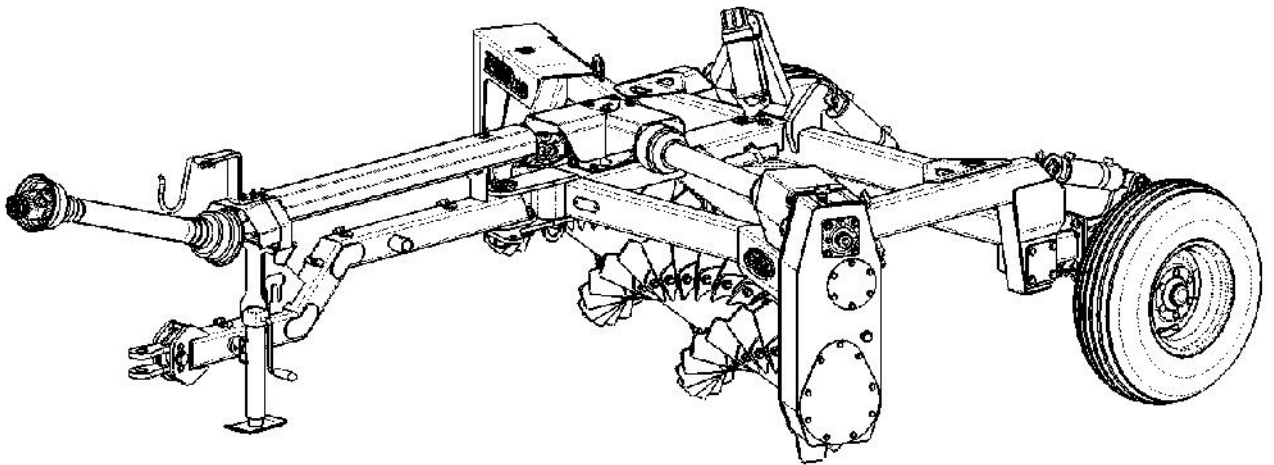

PARTS MANUAL



CAT # R0210-60002

ROCK RAKE PWD-10
R0210-00001



This symbol is the standard safety symbol. You will find it on most of the decals on your equipment. It is also used throughout this manual.

This symbol is used mainly to draw your attention and to warn you of possible dangers and/or potential injuries.

As the owner of this equipment, you are responsible for the safety of its users and those who are responsible for its maintenance. You and any other person using or performing maintenance on this equipment must be familiar with its operation and maintenance, as well as the safety measures contained in this manual. Having safe working practices guarantees a safer work environment.

Do not in any way modify this equipment. Unauthorized modifications could impair the proper functioning and/or safety of this equipment and possibly affect its useful life as well.

General Safety Measures

Read and understand all operating and safety instructions and guidelines contained in this manual prior to using, maintaining or adjusting the equipment.

Ensure all safety guards and shields are properly installed prior to using the equipment.

Always have a first aid kit within reach, and know how to use it.

Always have a fire extinguisher within reach, and know how to use it.

Know how to operate all controls, stop the rock rake and disengage all controls with haste.

Avoid wearing loose, cumbersome or torn clothing when you are near the rock rake.

Be extremely cautious while servicing or while near high pressure hydraulic systems. Ensure all components are fully sealed and in good working order prior to operating the equipment.

Operating Safety

Lower the rock rake, stop the tractor's engine, set controls to neutral, engage the emergency brake, remove the tractor's ignition key and wait for all moving parts to come to a full stop prior to adjusting, detaching or servicing the rock rake.

Keep hands, feet, hair and all clothing away from all moving parts and/or rotating parts.

Do not remove protective guards or shields. Ensure they are in place and properly attached.

Clear the area of all people, especially small children, prior to engaging the rock rake and/or the tractor.

Do not operate and do not leave the engine running in a non ventilated area.

Never perform adjustments, cleaning, and unclogging, greasing or other maintenance rock rake while engine is running.

Stay well away from the rock rake while it is in operation to avoid being hit by a flying rock and/or debris that may be ejected into the air.

Maintenance Safety

Lower the rock rake, stop the tractor's engine, set controls to neutral, engage the emergency brake, remove the tractor's ignition key and wait for all moving parts to come to a full stop prior to adjusting, detaching or servicing the rock rake.

Regularly check to make sure the bolts and screws are tight, and perform regular maintenance to keep the device in good working order.

Carefully examine the device to make certain that there is no damage.

Do not in any way modify this equipment, its components or its intended use. Fabrication S.Houle Inc. will not be held responsible should breakage or injury occur as a result of using any non-approved parts or accessories.

Decals

Here are images of the safety decals you will find on your rock rake. For your safety and protection, please ensure that these decals are always present and legible.

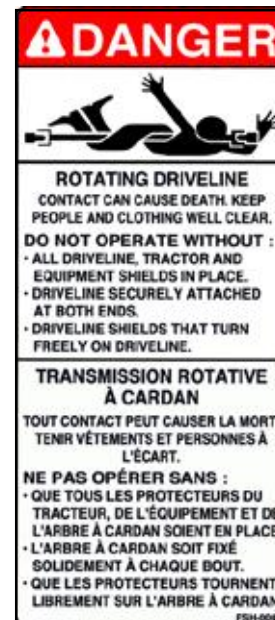



OPERATION

To the New Operator or Owner

The Fabrication SHOULE WD-10B Rock Rakes are designed to efficiently windrow rocks from 2 to 12 inches (50 to 300 mm) diameter. Many of the features incorporated into this machine are the result of suggestions made by customers like you.

It is the owner or operator's responsibility to read this manual carefully to learn how to operate the machine safely and how to set it to provide maximum efficiency. Safety is everyone's business. By following safe operating practices, a safe environment is provided for the operator and bystanders.

By following the operating instructions in conjunction with a good maintenance program, your Rock Rake will provide many years of trouble-free service.

Operation

Familiarize yourself with the various settings of the Rock Rake that are designed to allow the machine to work in a variety of field conditions. Field experience will indicate the combination of machine and operating condition to give a quality job. This section will cover the interaction of the field condition and machine setting

Rock Density

Rate the rock density as light, medium or heavy. Normally the machine ground speed will decrease as the rock density increases to insure that the teeth on the auger have the opportunity to make contact with each rock.

Soil Condition

Dry, firm ground is ideally suited for raking. Soft ground will require adjustments to the angling of the spiral drum to insure that the soil can fall between the teeth on the right end and not be moved into the windrow. Wet soil will ball up with the rocks and can plug the teeth. Give the soil more time to dry before raking.

It is recommended that the teeth on the left end of the drum penetrate the ground about 2 inches (50mm). Soft soil conditions require a lighter floatation; Hard soil a heavier floatation.

Auger RPM

Changing the engine speed changes the auger RPM. It is recommended that the PTO/Auger speed always be run at rated RPM and the ground speed be varied by changing gears in the tractor.

Forward Speed

The recommended ground speed varies from 2 to 6 mph (3,2 - 9,7 km/h) and is determined by rock density and size. When you see that rocks are being missed behind the machine, slow down. Increase the speed when the rock density decreases.

Transporting

Be sure the SMV sign is facing to the rear. Clean the SMV sign, lights, and reflectors

Always use the hazard flashers on the tractor when transporting

Do not exceed 20 mph (32 km/h) when transporting. Never exceed a safe travel speed. Slow down when cornering or on rough roads.



MAINTENANCE

Maintenance

Wipe the grease fittings with a clean cloth before greasing.
Lubricate all greasers for every eight hours of operation.



Verify drive chain tension after first eight hours of operation,
and then once a month. The chain can move 1/2".

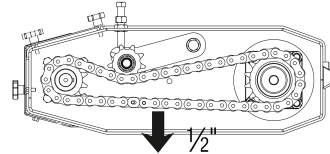

During adjustment of the torque limiter, the springs must be compressed to length of 1 5/16", which should be periodically verified. Warning: if the springs are compressed to a length inferior to 1 5/16", there is a risk of damage to the gearbox and the drive chain components.

1 5/16" → ←

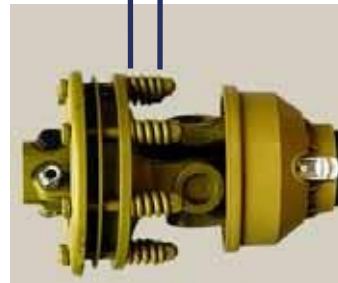

Check the gearbox oil level once a month. Perform oil change once a year, using gear oil grade 80W90.

The auger teeth have been designed to be easily inverted when one side becomes too worn. To invert, remove the bolts. Turn the tooth over and simply bolt it back into place. While facing the rock rake, place the tooth on the left side of its support.



ROCK RAKE PWD-10
R0210-00001

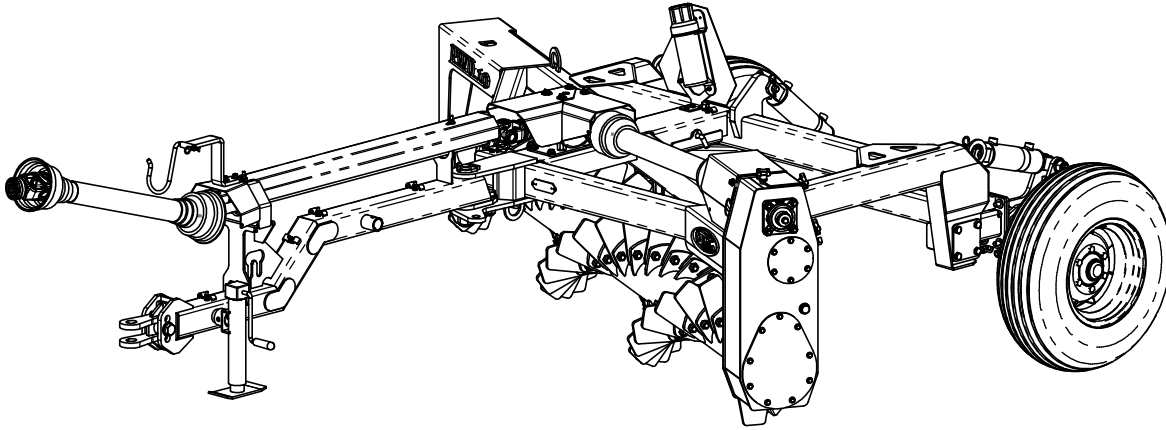

#	P. NUMBER	DESCRIPTION	QTY
1	R0210-03E01	WEEL AND HUB KIT	1
2	R0210-05E01	BODY ASS PWD-10	1
3	R0210-06E01A	DRIVE SYSTEM ASS PWD-10	1
4	R0210-29E01	HYD. HOSES KIT ROCK RAKE PWD	1
5	R0210-31E01	HYDRAULIC KIT ROCK RAKE PWD-10	1



WEEL AND HUB KIT R0210-03E01

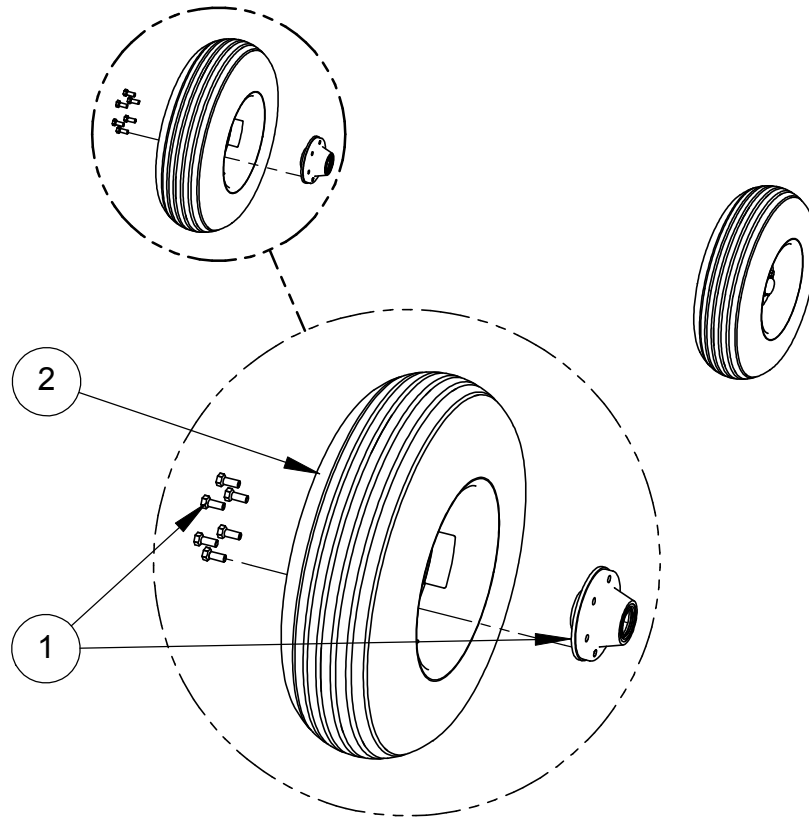

#	P. NUMBER	DESCRIPTION	QTY
1	01002	5000 LBS HUB	2
2	03002	TIRE AND WHEEL 11L-15	2



BODY ASS PWD-10
R0210-05E01

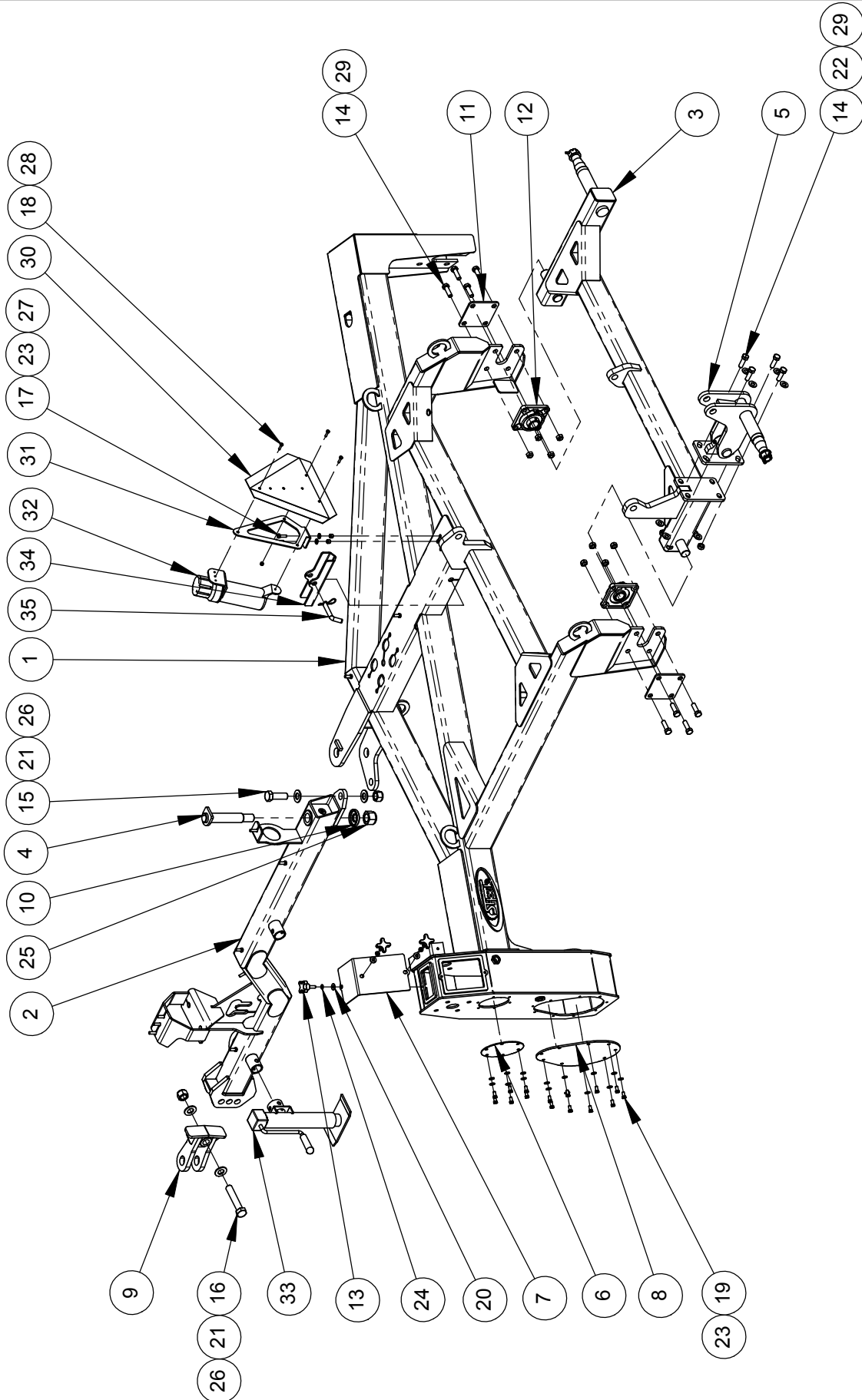



ENS CHASSIS PWD-10 R0210-05E01

#	P. NUMBER	DESCRIPTION	QTY
1	R-05006	FRAME	1
2	S-05007	HITCH POLE	1
3	R-05009	WHEELS SUPPORT	1
4	R-05010	HITCH POLE PIN 1 1/2	1
5	R-05011	WHEEL SUPPORT	1
6	R-05003	COVER	1
7	R-05004	COVER	1
8	R-05005	COVER	1
9	UN-20028	HITCH CLEVIS	1
10	UN-28008-3	COMPRESSION WASHER 2 1/4" IDx 2 3/4"ODx 1/4" (1 5/16")	1
11	UN-34001	FLANGE SUPPORT PLATE	2
12	34006-2	FLANGE BEARING 1 1/2" UCF208-24	2
13	35015	KNOB	3
14	45AA010110200	HEX BOLT 5/8-11NC x 2" GR5	12
15	45AA100080300	HEX BOLT 1-8NC X 3" GR5	1
16	45AA100080508	HEX BOLT 1-8NC x 5 1/2" GR5	1
17	45AA006160104	HEX BOLT 3/8-16NC x 1 1/4" GR5	2
18	45AA004200100	HEX BOLT 1/4-20NC x 1" GR5	3
19	45AC006160012	HEX BOLT FULL TREAD 3/8-16 x 3/4" GR5	15
20	46AA006	FLAT WASHER 3/8"	3
21	46AB100	HARDENED FLAT WASHER 1"	4
22	46AB010	HARDENED FLAT WASHER 5/8	8
23	46AB006	HARDENED FLAT WASHER 3/8"	17
24	46AC006	LOCK WASHER 3/8"	3
25	47AB10407	NYLON NUT 1 1/4-7NC	1
26	47AB10008	NYLON NUT 1-8NC	2
27	47AB00616	NYLON NUT 3/8-16NC	2
28	47AB00420	NYLON NUT 1/4-20NC	3
29	47AC01011	STOVER LOCK NUT 5/8-11NC	12
30	36002	SLOW MOVING VEHICLE SIGN (SMV)	1
31	UN-36001-2	SMV HOLDER	1
32	36001	MANUAL HOLDER 3 1/4"	1
33	43004	JACK 3000 LBS	1
34	UN-43004-04	CYL LOCKING DEVICE (10" X 1 1/2")	1
35	35011	BENT PULL PIN 5/8" X 3"	1



DRIVE SYSTEM ASS PWD-10 R0210-06E01B

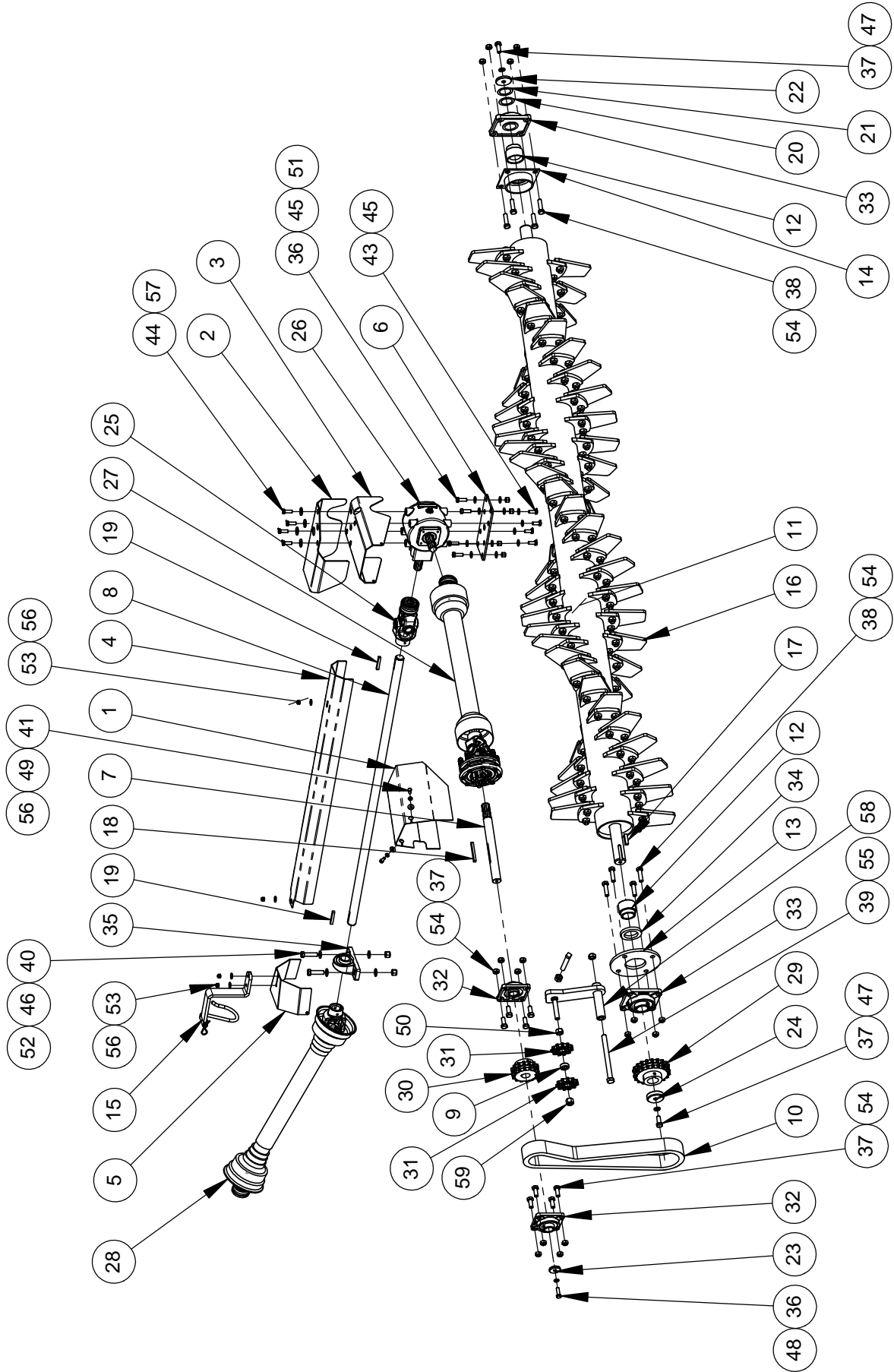



DRIVE SYSTEM ASS PWD-10 R0210-06E01A

#	P. NUMBER	DESCRIPTION	QTY
1	R-04001	TORQUE LIMITER PROTECTOR	1
2	R-04002	PROTECTOR	1
3	R-04003	PROTECTOR	1
4	R-04004	GUARD	1
5	R-04005	GUARD	1
6	R-06002	BASE PLATE	1
7	R-06003	SHAFT	1
8	R-06004	DRIVE SHAFT	1
9	R-06026	SPACER	1
10	R-07009	DRIVE CHAIN 80-2	1
11	R-14001	SPIRAL DRUM	1
12	R-14004	SPACER	2
13	R-14005	OIL SEAL SUPPORT	1
14	R-14006	PROTECTOR	1
15	R-43005	PTO HOLDER	1
16	R0110-14E01	ROCK RAKE TOOTH KIT	1
17	UN-06001-8	KEY 1/2" X 1/2" X 2"	1
18	UN-06001-9	KEY 3/8" X 3/8" X 4" 2RE	1
19	UN-06001-20	KEY 3/8" X 3/8" X 2 11/16" 1RE	2
20	UN-28006-2	SHIM 2" 18GA	1
21	UN-28006-3	SHIM 2" 22GA	1
22	UN-28007-2	WASHER 5/8" ID X 2 3/4" OD X 3/8"	1
23	UN-28007-3	WASHER 1/2" ID X 2" OD X 3/8"	1
24	UN-28008-2	COMPRESSION WASHER 2" IDx 3"ODx 1/2" (5/8")	1
25	06059	UNIVERSEL JOINT 60 SERIE (1 1/2 KEY 3/8_1 3/8-6)	1
26	06029	GEAR BOX COMER T304A 3:1	1
27	06048	PTO-T60 x 34" (1 3/8-6 COLLAR x TORQUE LIMITER F4)	1
28	06053	PTO T60 x 34" (1 1/2 KEY 3/8_1 3/8-6 COLLAR)	1
29	07036-4	SPROCKET D80B19 (2.000)	1
30	07036-3	SPROCKET D80B14 (1.500)	1
31	07040-2	SPROKET (IDLER) 80A11H1	2
32	34006-2	FLANGE BEARING 1 1/2" UCF208-24	2
33	34006-3	FLANGE BEARING 2" UCF211-32	2
34	34011	OIL SEAL 2 1/2" (2.500*3.756*.500	1
35	34017	PILLOW BLOCK 1 1/2"	1
36	45AA008130108	HEX BOLT 1/2-13NC X 1 1/2" GR5	5
37	45AA010110108	HEX BOLT 5/8-11NC x 1 1/2" GR5	10
38	45AA010110204	HEX BOLT 5/8-11NC x 2 1/4" GR5	8
39	45AA012100900	HEX BOLT 3/4-10NC x 9" GR5	1
40	45AA010110208	HEX BOLT 5/8-11NC x 2 1/2" GR5	2
41	45AA006160100	HEX BOLT 3/8-16NC x 1" GR5	2
42	45DB012100408	SQUARE HEAD SET SCREW 3/4"-10NC X 4 1/2"	1
43	45MA12175030	METRIC BOLT M12 X 1.75 X 30 GR 8.8	4
44	45MA12175035	METRIC BOLT M12 X 1.75 X 35 GR 8.8	4
45	46AB008	HARDENED FLAT WASHER 1/2"	12
46	46AB010	HARDENED FLAT WASHER 5/8"	4
47	46AC010	LOCK WASHER 5/8"	2
48	46AC008	LOCK WASHER 1/2"	1
49	46AC006	LOCK WASHER 3/8"	2
50	47AA10014	HEX NUT 1-14NF	2
51	47AB00813	NYLON LOCK NUT 1/2-13 NC	4
52	47AB01011	NYLON NUT 5/8-11NC	2
53	47AB00616	NYLON LOCK NUT 3/8"-16NC	4
54	47AC01011	STOVER LOCK NUT 5/8-11NC	16
55	47AC01210	STOVER LOCK NUT 3/4-10NC	1
56	46AA006	FLAT WASHER 3/8"	6
57	46AA008	FLAT WASHER 1/2"	4
58	R-06001	CHAIN TENSIONER	1
59	47AB10014	NYLON NUT 1-14NF	1



HYDRAULIC KIT ROCK RAKE PWD-10 R0210-31E01

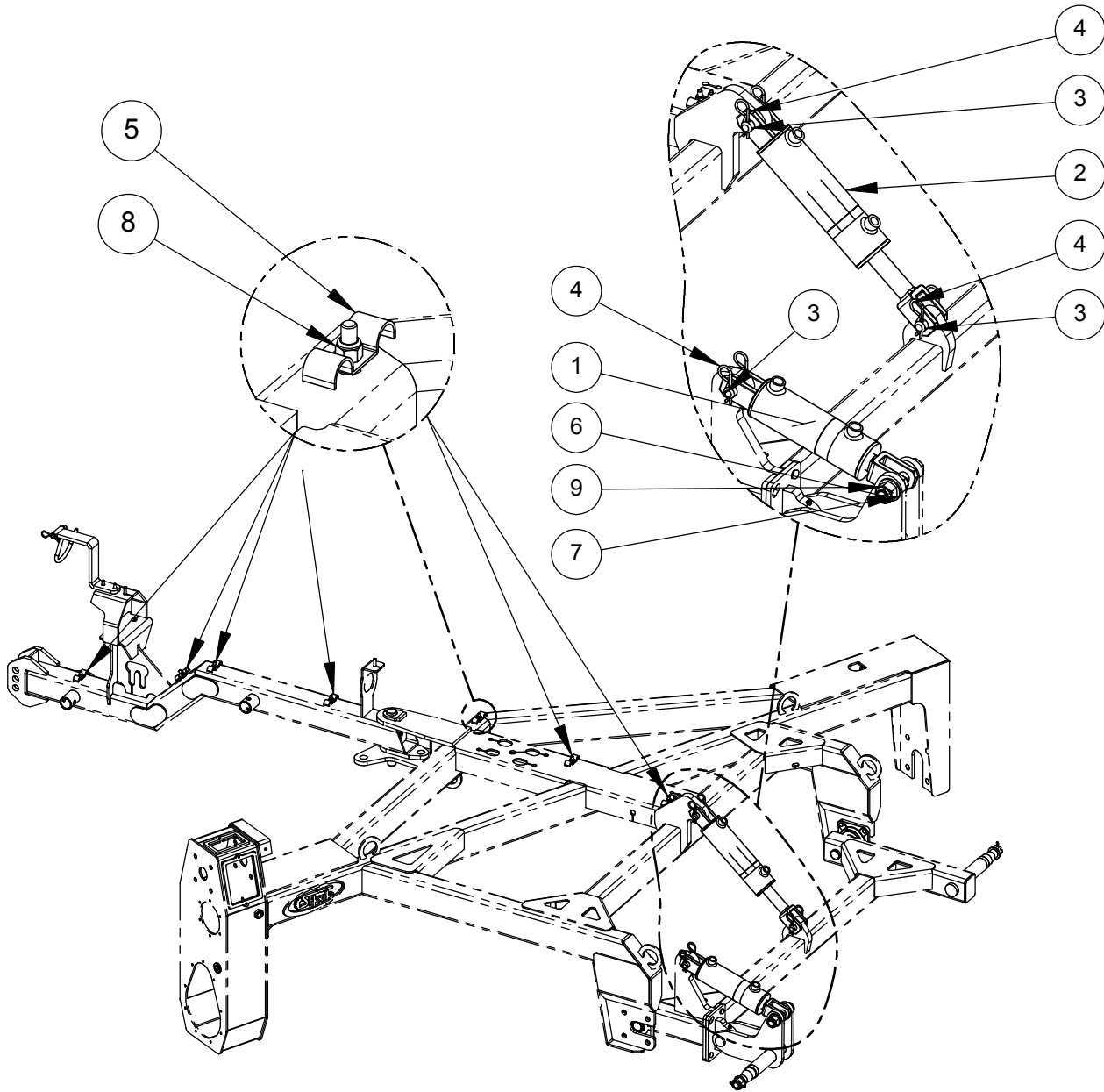

#	P. NUMBER	DESCRIPTION	QTY
1	30002	HYD CYLINDER 3 X 6	1
2	30002-2	HYD CYLINDER 3 X 8	1
3	UN-25001-8	PIN 1" X 3 1/2"	3
4	35014	HITCH PIN CLIPS 3/16" X 3 1/4"	6
5	31015	5/8" DOUBLE HOSE CLAMP	7
6	45AA100080500	HEX BOLT 1-8NC x 5" GR5	1
7	46AB100	HARDENED FLAT WASHER 1"	2
8	47AB00616	NYLON NUT 3/8-16NC	7
9	47AB10008	NYLON NUT 1-8NC	1



ROCK RAKE TOOTH KIT R0110-14E01

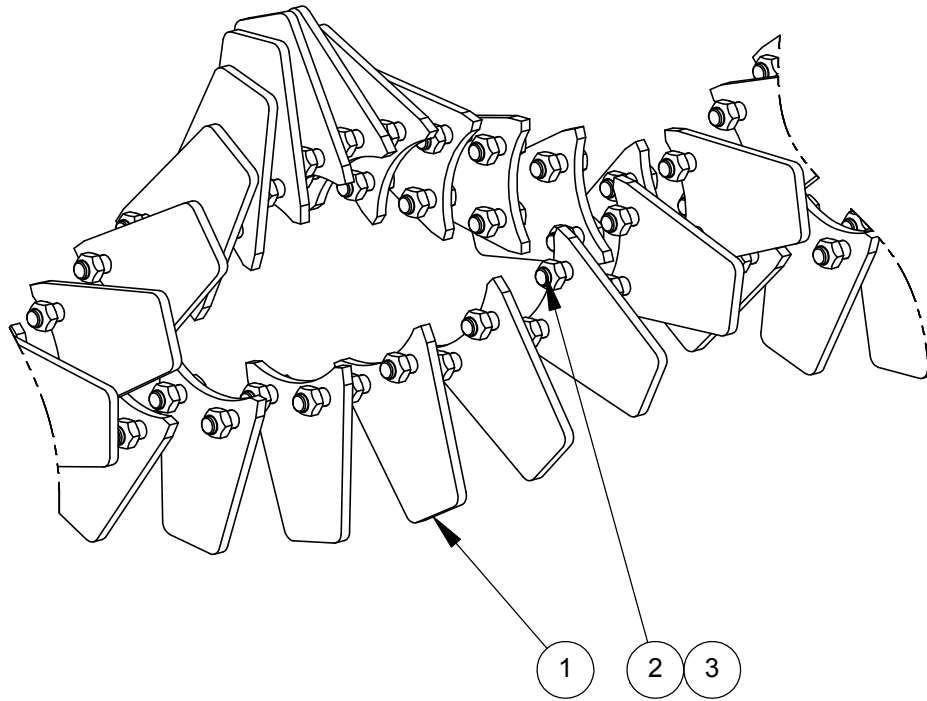

#	P. NUMBER	DESCRIPTION	QTY
1	UN-14002	ROCK RAKE TOOTH	61
2	45AA012160200	HEX BOLT 3/4-16NF x 2" GR5	122
3	47AC01216	STOVER LOCK NUT 3/4-16NF	122



**PTO T60 x 34" (1 1/2 KEY 3/8_1 3/8-6 COLLAR)
06053**

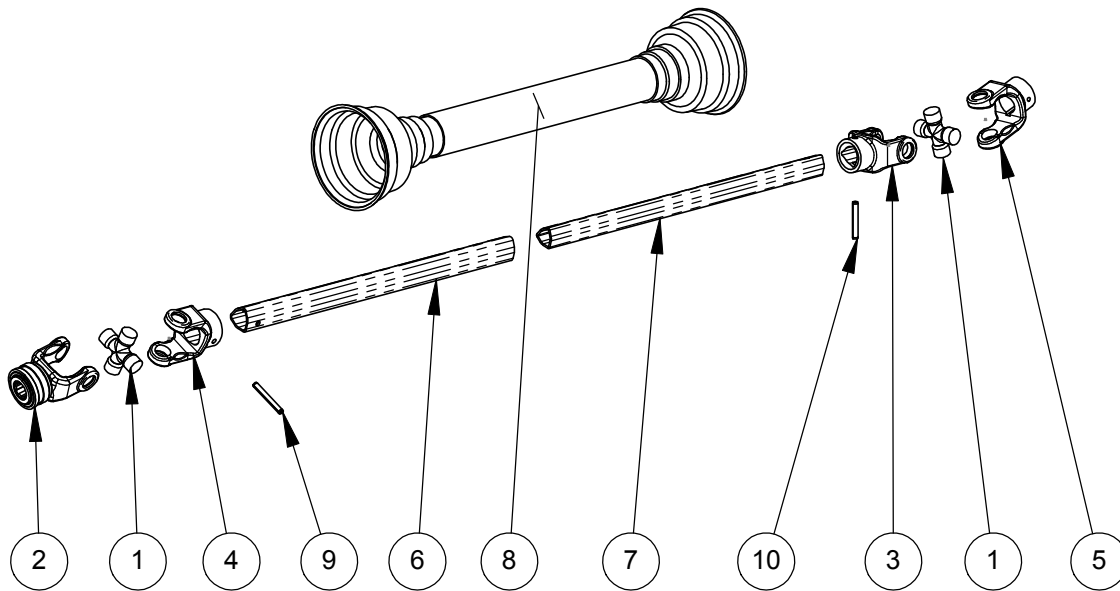

#	P. NUMBER	DESCRIPTION	QTY
1	06012-4	CROSS 60 SERIES	2
2	06013-4	COLLAR YOKE 60 SERIES 1 3/8 -6	1
3	06014-4	INNER TUBE YOKE T60 SERIES	1
4	06015-4	OUTER TUBE YOKE T60 SERIES	1
5	06021-5	YOKE 60 SERIES_1 1/2 KEY 3/8	1
6	06039-4	OUTER TUBE T60 SERIES (27 1/2")	1
7	06040-4	INNER TUBE T60 SERIES (28 1/8")	1
8	06071	COMPLETE GUARD T60 (860mm)	1
9	49AB10080	METRIC SPRING PIN 10 X 80	1
10	49AB10070	METRIC SPRING PIN 10 X 70	1



**PTO-T60 x 36" (1 3/8-6 COLLAR x TORQUE LIMITER F4)
06048**

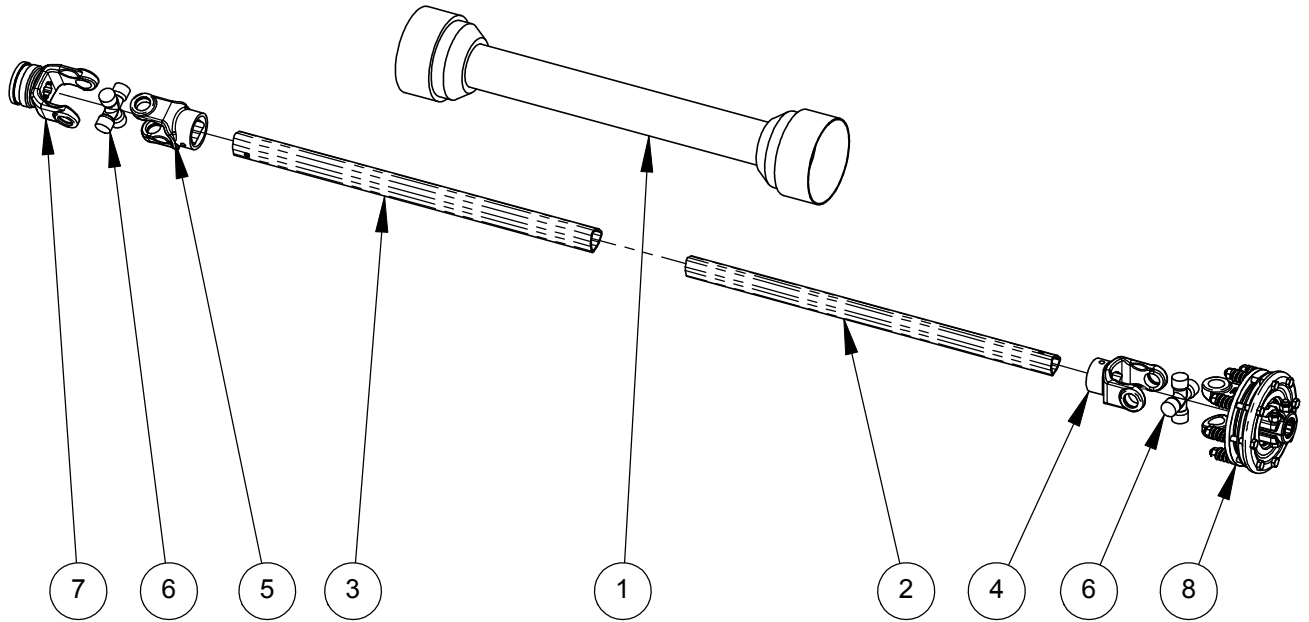

#	P. NUMBER	DESCRIPTION	Qty
1	06044-3	COMPLETE GUARD T60 SERIES (38")	1
2	06040-3	INNER TUBE T60 SERIES (30 1/8")	1
3	06039-3	OUTER TUBE T60 SERIES (29 1/2")	1
4	06014-4	INNER TUBE YOKE T60 SERIES	1
5	06015-4	OUTER TUBE YOKE T60 SERIES	1
6	06012-4	CROSS 60 SERIES	2
7	06013-4	COLLAR YOKE 60 SERIES 1 3/8 -6	1
8	06031	DISC CLUTCH TORQUE LIMITER SERIES 60 F4	1



DISC CLUTCH TORQUE LIMITER SERIES 60 F4 06031

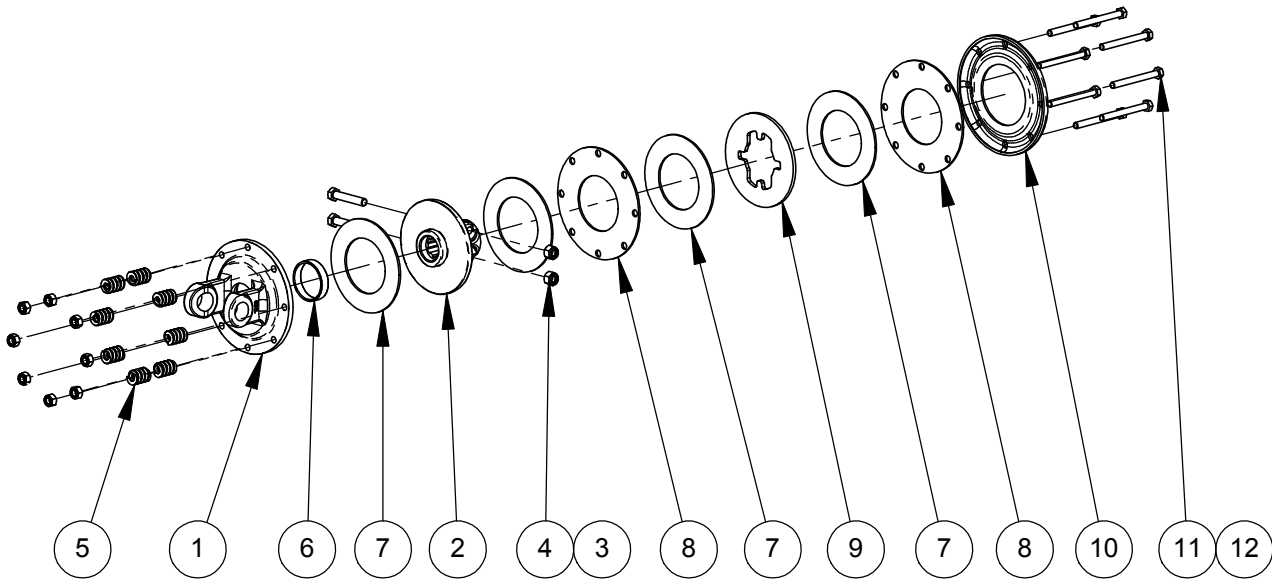

#	P. NUMBER	DESCRIPTION	QTY
1	06031-1	HEAVY DUTY FLANGED YOKE (T-60)	1
2	06031-2	CLUTCH SUPPORT	1
3	06031-3	METRIC BOLT M12 X 1.75 X 65mm	2
4	06031-4	NYLON HEX. NUT M12 X 1.25	2
5	06030-1	SPRING 6MM DIA	8
6	06030-3	BUSHING	1
7	06030-4	LINING RING	4
8	06030-6	INNER PLATE	2
9	06030-7	INTERMEDIATE PLATE	1
10	06030-8	PRESSURE PLATE	1
11	06030-10	BOLT M10 X 1.5 X 100mm	8
12	06031-11	NYLON HEX NUT M10 X 1.5	8



UNIVERSEL JOINT 60 SERIE (1 1/2 KEY 3/8_1 3/8-6) 06059

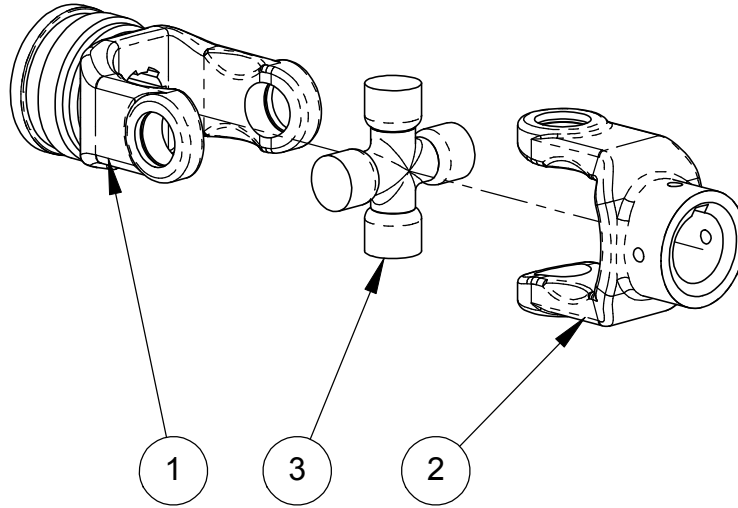

#	P. NUMBER	DESCRIPTION	QTY
1	06013-4	COLLAR YOKE 60 SERIES 1 3/8 -6	1
2	06021-5	YOKE 60 SERIES_1 1/2 KEY 3/8	1
3	06012-4	CROSS 60 SERIES	1



GEAR BOX COMER T304A 3:1 06029

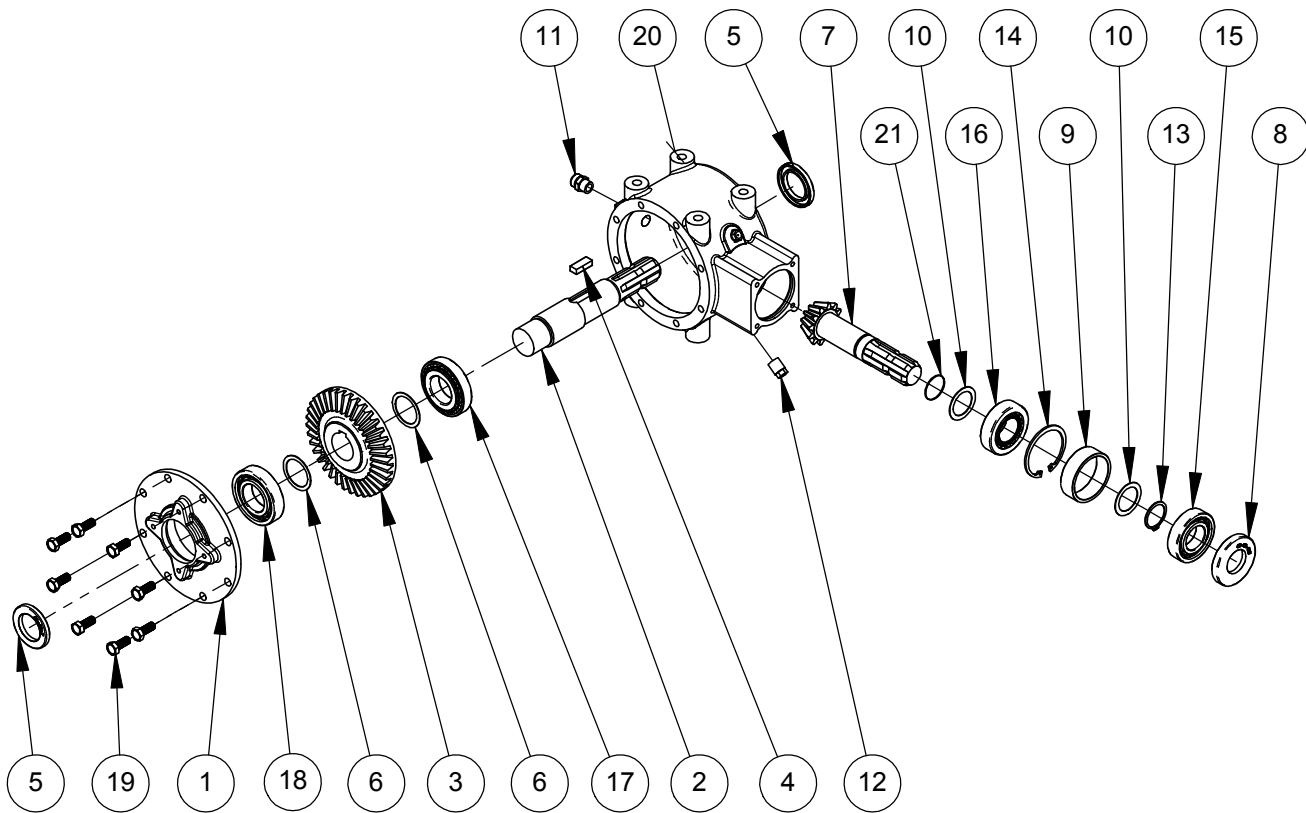

#	P. NUMBER	DESCRIPTION	QTY
1	06029-1	COVER	1
2	06029-2	SHAFT	1
3	06029-3	CROWN WHEEL Z36 - M4 - 35	1
4	06029-4	KEY 12x8x30	1
5	06029-5	OIL SEAL 40x62x7	2
6	06029-6	SHIM 51,5mm	2
7	06029-7	PINION SHAFT Z12 - M4 - 35	1
8	06029-8	OIL SEAL 35x72x10/7	1
9	06029-9	SPACER	1
10	06029-10	SHIM 48mm	2
11	06029-11	OIL FILLER PLUG 3/8"	1
12	06029-12	PLUG 3/8"	2
13	06029-13	CIRCLIP DIN 471 - 35 X 1.5	1
14	06029-14	CIRCLIP DIN 472 - 72 X 2.5	1
15	06029-15	SKF - 6207 - FULL,DE,AC,FULL_68	1
16	06029-16	BEARING SKF - 32207	1
17	06029-17	SKF - 30208 - 16,DE,AC,16	1
18	06029-18	SKF - 6208 - FULL,DE,AC,FULL_68	1
19	06029-19	B18.2.3.2M - FORMED HEX SCREW, M10 X 1.5 X 25 --25CN	8
20	06029-20	CASING T-304A	1
21	06029-21	SHIM 35mm	1



Fabrication SHoule limited guarantee on agricultural and commercial equipment

Fabrication SHoule Inc guarantees every new farm and commercial product of the manufacturer SHoule against any defect of material and manufacturing, within the framework of a normal use, during one year after the date of retail purchase SHoule will guarantee its product for (1) year, on parts and imperfection of manufacturing This Limited

Guarantee will apply only to equipments made by S.Houle

EQUIPMENT AND ACCESSORIES WHICH ARE NOT MADE BY S HOULE ARE GUARANTEED ONLY IN THE MEASURE WHICH THE GUARANTEE OF THE ORIGINAL MANUFACTURER DETERMINES AND APPROVES THAT THERE IS A MANUFACTURING DEFECT

During the period limited by guarantee indicated above, any defect in the material (equipment) or in the manufacturing of any equipment fabricated by S.Houle will be repaired or replaced without responsibility by an authorized independent retailer. An authorized retailer has to make the repair under guarantee or the replacement of parts. The costs of labour must be approved by manufacturing SHoule before beginning (undertaking) the works otherwise these could be totally refused, according to the politics (policy) of working refund (repayment) of S.Houle. SHoule reserves the right to supply parts, for replacement which he (it) considers appropriate.

RESPONSIBILITY OF THE BUYER: This limited guarantee requires (demands) the appropriate maintenance and the overhauls of the agricultural or commercial equipment such as indicated in operator manual supplied with the new equipment. The cost of the regular maintenance or the required services is the responsibility of the buyer. The buyer has to keep his invoices which prove that the maintenance was made.

The limited guarantee may be revoked (dismissed) by Fabrication S.Houle if the above mentioned conditions (requirements) are not respected.

EXCLUSIONS AND LIMITATIONS

Guarantees WILL NOT APPLY on:

- 1 Any defect which was caused (according to the judgment of SHoule by a use other than that normally planned, or by the following causes: (i) accident (ii) a misuse or a carelessness (negligence) (iii) excessive use (iiii) lack of reasonable and appropriate maintenance, (v) incorrect repair or bad installation (vi) or when warehoused (stored away) (vii) modification not authorized by SHoule (viii) natural disasters (ix) vandalism (x) parts, or accessories installed on the equipment which were not made or not installed by the authorized retailer (xi) elements (xii) collision or accidents
- 2 Any agricultural or commercial equipment which the identification number or serial number or the trade names were changed or removed
- 3 Any agricultural or commercial equipment on services of which the required or recommended overhaul were executed by using parts not made, approved or supplied by SHoule or not meeting the specifications, but without limitation, lubricants (oil, grease) and liquids for hydraulics
- 4 The equipment used for rental, industrial work, construction or if the equipment is used for a purpose other than the application in which it was designated (design) for by SHoule
- 5 Any equipment used for field demonstrations by a retailer not approved by S.Houle. The guarantee will be to the discretion of S.Houle or any other demonstration
- 6 Any defect which was caused (according to the judgment of S.Houle) by the operation of the equipment without submitting itself to the standard (in the standard) procedures of exploitation (operation) described in operator manual
- 7 The guarantee on tires is the responsibility of the manufacturer of the respective product
- 8 Cost of the transport, if necessary, to transport to the retailer S.Houle
- 9 In no case the responsibility of S.Houle can exceed the cost of the product
- 10 SHoule will be subjected in no circumstances to compensate, whoever it is, for the loss of income for a discontinued equipment, for a time of the repairs no matter the reason for this breakdown.
- 11 The costs of estimation or the diagnostic and the overtime of work for the repair are not covered under this limited guarantee policy.
- 12 The depreciation caused by the normal wear, the lack of reasonable and appropriate maintenance, the misuse, and/or the lack of protection during warehousing
- 13 Accessories and electronic components which are not of or from S.Houle are guaranteed only under the limited guarantee by this manufacturer.
- 14 Articles of wear which are registered by the group of products below:

Normal wear parts: flow divider, wear plates, the bolts, the nuts, spring blades, the swivel skid shoe, the special bolts of swivelling skid shoe, slide channels, chains and chain attachments, cast iron shoe, hydraulic hoses, swivel, clutch and their components, the gear box, the shaft, ...

EXCLUSION FROM GUARANTEES: SHOULE RESERVES THE RIGHT TO MODIFY, TO CHANGE AND TO IMPROVE THEIR PRODUCTS WITHOUT INCURRING ANY OBLIGATION TO REPLACE PRODUCTS PREVIOUSLY SOLD WITH SUCH A MODIFICATION. NO PERSON IS AUTHORIZED TO GIVE ANOTHER GUARANTEE, OR TO ASSUME ANY ADDITIONAL OBLIGATION ON EQUIPMENTS MADE BY S.HOULE.



Fabrication S.Houle inc.

300 Industrial blvd. P.O. box 750
St-Germain-de-Grantham, Quebec, Canada, J0C 1K0
Phone : 819 395-4380 Fax. : 819 395-5516
Toll free : 1 888-404-4380
E-Mail : info@shoule.com Web : www.shoule.com

Product Registration

Dealer instructions:
Make sure registration is complete and signed.

Product Information :

MACHINE MODEL : _____ DELIVERY DATE : _____ / _____ / _____
mm dd yyyy
SERIAL NUMBER : _____
OPTIONAL EQUIPMENT : _____

Customer Information :

FIRST & LAST NAME : _____ PHONE : _____
MAILING ADDRESS : _____ EMAIL : _____
Civic number and street
City
State / Province Zip Code

Dealer Information :

DEALER NAME : _____ PHONE : _____
MAILING ADDRESS : _____ EMAIL : _____
Civic number and street
City
State / Province Zip Code

Signatures :

Owner or designated representative signature

Authorized dealer signature
Note : Both dealer and owner must sign in order to validate the warranty.

I hereby acknowledge that:

- | | |
|--|--|
| <ol style="list-style-type: none">1. I have received and accepted delivery of equipment described.2. The equipment was checked thoroughly for loose or missing parts and has been adjusted in accordance with the pre-delivery checklist.3. I have been provided with and have carefully read the instruction manual.4. I have read and understand the nature and extent of the warranty and understand clearly that there were and are no other representations or warranties, either express or implied, made by anyone.5. A copy of the present document must be completed and transmitted to Fa- | <ol style="list-style-type: none">6. brication S.Houle as soon as possible, in order to process your warranty.6. I have been advised on proper operation, maintenance and lubrication procedures of this equipment.7. I have been instructed on and do understand the application, limitations and capacities this equipment was designed and recommended for, all as described in the Instruction Manual and other literature published by Fabrication S.Houle inc. |
|--|--|

ONE YEAR WARRANTY COVER PARTS ONLY, EFFECTIVE WHEN THIS FORM HAS ALL APPLICABLE INFORMATION COMPLETED, IS SIGNED BY BOTH THE OWNER AND THE DEALER AT THE TIME OF DELIVERY, THEN FORWARDED TO **FABRICATION S.HOULE INC.** WARRANTY SERVICE MAY BE DENIED IF THIS FORM CONTAINS FALSE INFORMATION OR IS INCOMPLETE.



Fabrication S.Houle inc.

300 boul. Industriel, boîte postale 750
St-Germain-de-Grantham, Québec, Canada, J0C 1K0
Tél : 819 395-4380 Téléc. : 819 395-5516
Sans frais : 1 888-404-4380
Courriel : info@shoule.com Site : www.shoule.com

Fabrication S.Houle inc.

300 Industrial blvd, C P 750
St-Germain-de-Grantham, Québec, Canada, J0C 1K0T
Phone : 819 395-4380 Fax. : 819 395-5516
Toll free : 1 888-404-4380
E-mail : info@shoule.com Web : www.shoule.com