

OPERATOR'S MANUAL
AND
SET-UP INSTRUCTIONS
FOR THE

**HD-100 Series
Chain Harrow**

All Models

version: MM-0201(10-16)
Starting at Serial Number 17876

TO THE OWNER AND OPERATORS

Before assembling or operating this unit, READ THIS MANUAL THOROUGHLY. To obtain the best performance of the unit, familiarize yourself with each component and adjustment. Store this manual where it can be readily available for future reference. In the event that the harrow or any part of the unit should be sold, be sure that the new owner receives a copy of this manual for their reference.

TABLE OF CONTENTS

INTRODUCTION	3
LIMITED WARRANTY	3
SAFETY	4
CONTACT INFORMATION.....	5
LIGHTING AND MARKING.....	6
SAFETY SIGN CARE	7
TIRE SAFETY.....	7
BEFORE OPERATION.....	7 - 8
DURING OPERATION	8 - 9
FOLLOWING OPERATION	9
HIGHWAY AND TRANSPORT OPERATIONS	9 - 10
PERFORMING MAINTENANCE	10
MAINTENANCE AND SERVICE SCHEDULE	11
OPERATING SUGGESTIONS.....	11
ASSEMBLY SUGGESTIONS.....	12
ASSEMBLY INSTRUCTIONS	13 – 23
FINAL ADJUSTMENTS	23
TROUBLESHOOTING.....	24
BOLT TORQUE SPECIFICATIONS	APPENDIX A
PARTS DIAGRAMS AND LISTS	APPENDIX B
LAYOUT DIAGRAMS.....	APPENDIX C
WARRANTY REGISTRATION FORM.....	LAST PAGE

INTRODUCTION

Thank you for purchasing your new McFarlane transport cart and harrow sections. We know that you will get many years of dependable service from this modernly designed unit.

You may have had a particular application in mind when you purchased this unit. There are actually many uses for the McFarlane harrow including incorporation of herbicides and pesticides, leveling and smoothing tilled soil, and covering of broadcast seeds. Contact your dealer if you would like more information or have questions concerning these or other applications.

LIMITED WARRANTY

FULL ONE - YEAR WARRANTY OF HD-100 Series

If within one year from the date of purchase, this transport cart and/or its accompanying harrow sections fail due to defect in material or workmanship, McFarlane Mfg. Co., Inc. will repair it, free of charge.

Warranty service is available by simply contacting the nearest McFarlane dealership throughout the United States or Canada.

This warranty applies only while this product is used in the United States or Canada.

This warranty gives you specific legal rights, and you may have other rights which vary from state to state.

McFarlane Mfg. Co., Inc., Sauk City, Wisconsin 53583

SAFETY

TAKE NOTE! THIS SAFETY ALERT SYMBOL FOUND THROUGHOUT THIS MANUAL IS USED TO CALL ATTENTION TO INSTRUCTIONS INVOLVING YOUR PERSONAL SAFETY AND THE SAFETY OF OTHERS. FAILURE TO FOLLOW THESE INSTRUCTIONS CAN RESULT IN INJURY OR DEATH.



THIS SYMBOL MEANS

- **ATTENTION!**
- **BECOME ALERT!**
- **YOUR SAFETY IS INVOLVED!**

SIGNAL WORDS:

Note the use of the signal words DANGER, WARNING, and CAUTION with the safety messages. The appropriate signal word for each has been selected using the following guidelines:

DANGER: Indicates an imminently hazardous situation that, if not avoided, will result in death or serious injury.

WARNING: Indicates a potentially hazardous situation that, if not avoided, could result in death or serious injury.

CAUTION: Indicates a potentially hazardous situation that, if not avoided, may result in minor or moderate injury.

CONTACT INFORMATION

If you have questions not answered in this manual, require additional copies, or the manual is damaged, please contact your local dealer or:

McFarlane Mfg. Co., Inc.
1330 Dallas Street
P.O. Box 100
Sauk City, WI 53583

PHONE: (608) 643-3322
TOLL FREE: (888) 627-8569
FAX: (608) 643-3976
INTERNET: www.flexharrow.com
EMAIL: info@flexharrow.com



SAFETY FIRST!



Equipment Safety Guidelines

Safety of the operator is one of the main concerns in designing and developing a new piece of equipment. Designers and manufacturers build in as many safety features as possible. However, every year many accidents occur which could have been avoided by a few seconds of thought and a more careful approach to handling equipment. You, the operator, can avoid many accidents by observing the following precautions. To avoid personal injury, study the following precautions and insist that those working with you, or for you, follow them.

Replace any CAUTION, WARNING, DANGER, or instruction safety decal that is not readable or missing.

Do not attempt to operate this equipment under the influence of drugs or alcohol.

Review the safety instructions with all users annually.

This equipment is dangerous to children and persons unfamiliar with its operation. The operator should be a responsible adult familiar with farm machinery and trained in this equipment's operations. **Do not allow persons to operate or assemble this unit until they have read this manual and have developed a thorough understanding of the safety precautions and of how it works.**

To prevent injury, use a tractor equipped with a Roll Over Protective System (ROPS). Do not paint over, remove, or deface any safety signs or warning decals on your equipment. Observe all safety signs and practice the instructions on them.

Never exceed the limits of the transport cart or the harrows. If their ability to do a job, or to do so safely, is in question - **DO NOT TRY IT.**



Lighting and Marking

It is the responsibility of the customer to know the lighting and marking requirements of the local highway authorities and to install and maintain the equipment to provide compliance with the regulations. Add extra lights when transporting at night or during periods of limited visibility.

Lighting kits are available from your dealer.



Safety Sign Care

- Keep safety signs clean and legible at all times.
- Replace safety signs that are missing or have become illegible.
- Replacement parts that display a safety sign should display the same sign.
- Safety signs are available from your Distributor, Dealer Parts Department, or the factory.

How to Install Safety Signs:

- Be sure that the installation area is clean and dry.
- Decide on the exact position before you remove the backing paper.



Tire Safety

- Failure to follow proper procedures when mounting a tire on a wheel or rim can produce an explosion which may result in serious injury or death.
- Do not attempt to mount tires unless you have the proper equipment and experience to do the job.
- Inflating or servicing tires can be dangerous. Whenever possible, trained personnel should be called to service and/or mount tires.
- Always order and install tires and wheels with appropriate capacity to meet or exceed the weight of the unit. Be sure to inflate tires to tire manufacturer's specifications
- Tires that are provided by the manufacturer are designed for speeds LESS THAN 20mph. Do Not exceed or tire failure will occur.



Remember:

Your best assurance against accidents is a careful and responsible operator. If there is any portion of this manual or function you do not understand, contact your local authorized dealer or the manufacturer.



Before Operation:

- Carefully study and understand this manual.
- Do not wear loose fitting clothing which may catch in moving parts.
- Always wear protective clothing and substantial shoes.
- It is recommended that suitable protective hearing and (eye protection) sight protectors be worn.
- Keep wheel lug nuts or bolts tightened.
- Assure that the tires are inflated evenly.
- Give the unit a visual inspection for any loose bolts, worn parts, or cracked welds, and make necessary repairs. Follow the maintenance safety instructions included in this manual.
- Before using the hydraulics on the cart, be sure all fittings and connections are tight.
- Be sure that there are no tools lying on the unit.
- Make sure that the area is clear of children, animals, and other obstacles before using.
- Don't hurry the learning process or take the unit for granted. Ease into it and become familiar with your new equipment. Practice operation of your new unit. Completely familiarize yourself and other operators with its operation before using.

- Securely attach to towing unit. Use a high strength, appropriately sized hitch pin with a mechanical retainer and attach safety chain.
- Do not allow anyone to stand between the tongue or hitch and the towing vehicle when backing up to the equipment.



During Operation:

- **SAFETY CHAIN** - If equipment is going to be transported on a public highway, a safety chain should be obtained and installed. Always follow state and local regulations regarding a safety chain when towing farm equipment on a public highway. Be sure to check with local law enforcement agencies for your own particular regulations. Only a safety chain (not an elastic or nylon/plastic tow strap) should be used to retain the connection between the towing and towed machines in the event of separation of the primary attaching system.
- Install the safety chain by crossing the chains under the tongue and secure to the draw bar cage or hitch or bumper frame.
- Beware of bystanders, **particularly children!** Always look around to make sure that it is safe to start the engine of the towing vehicle or move the unit. This is particularly important with higher noise levels and quiet cabs, as you may not hear people shouting.
- **NO PASSENGERS ALLOWED** - Do not carry passengers anywhere on, or in, the tractor or equipment, except as required for operation.
- Keep hands and clothing clear of moving parts.
- Do not clean, lubricate, or adjust your equipment while it is moving.
- When altering operation, even periodically, set the tractor or towing vehicle brakes, shut off the engine, and **remove the ignition key.**
- Do not operate the hydraulic cylinders without the flow restrictors installed; the free falling harrow sections may cause serious injury.
- Pick the levellest possible route when transporting across fields. Avoid the edges of ditches or gullies and steep hillsides.
- Periodically clear the equipment of brush, twigs, or other materials to prevent buildup of dry combustible materials.
- Maneuver the tractor or towing vehicle at safe speeds.
- Avoid overhead wires or other obstacles. Contact with overhead lines could cause serious injury or death.
- Allow for unit length when making turns.
- Do not walk or work under raised wings unless securely positioned in wing rests.
- Keep all bystanders, pets, and livestock clear of the work area, particularly when raising or lowering harrow sections.
- Operate the towing vehicle from the operator's seat only.
- As a precaution, always recheck the hardware on equipment periodically. Correct all problems. Follow the maintenance safety procedures.



Following Operation:

- When disconnecting, stop the tractor or towing vehicle, set the brakes, secure the wings in the wing rests, relieve hydraulic fluid pressure, shut off the engine and **remove the ignition keys**. Make sure all jack and support stands are in place before removing hitch pins.
- Store the unit in an area away from human activity on a hard level surface.
- Do not park equipment where it will be exposed to livestock for long periods of time. Damage and livestock injury could result.
- Do not permit children to play on or around the stored unit.



Highway and Transport Operations:

- Make sure all transport lock provisions are in place and jack/parking stands are in their storage position before transporting the unit.
- Adopt safe driving practices:
 - Keep the brake pedals latched together at all times. **NEVER USE INDEPENDENT BRAKING WITH MACHINE IN TOW AS LOSS OF CONTROL AND/OR UPSET OF UNIT MAY RESULT.**
 - Always drive at a safe speed relative to local conditions and ensure that your speed is low enough for an emergency stop to be safe and secure. Keep speed to a minimum.
 - Reduce speed prior to turns to avoid the risk of overturning.
 - Avoid sudden uphill turns on steep slopes.
 - Always keep the tractor or towing vehicle in gear to provide engine braking when going downhill. Do not coast.
 - Do not drink and drive!
- Comply with state and local laws governing highway safety and movement of farm machinery on public roads.
- Use approved accessory lighting flags and necessary warning devices to protect operators of other vehicles on the highway during daylight and nighttime transport. Various safety lights and devices are available from your dealer.
- The use of flashing amber lights is acceptable in most localities. However, some localities prohibit their use. Local laws should be checked for all highway lighting and marking requirements.
- When driving the tractor and equipment on the road or highway under 20 mph at night or driving during the day, use flashing amber warning lights and a slow moving vehicle (SMV) identification emblem.
- Remember, tires supplied by the manufacturer are designed to operate LESS THAN 20mph. Do Not exceed or tire failure will occur.
- Be a safe and courteous driver. Always yield to oncoming traffic in all situations, including narrow bridges, intersections, etc. Plan your route to avoid heavy traffic.

- Be observant of bridge loading ratings. Do not cross bridges rated lower than the gross weight at which you are operating.
- Watch for obstructions overhead and to the side while transporting.
- Always operate equipment in a position to provide maximum visibility at all times. Make allowances for increased length and weight of the equipment when making turns, stopping, etc.



Performing Maintenance:

- Good maintenance is your responsibility. Poor maintenance is an invitation to trouble.
- Before working on this machine, stop the tractor or towing vehicle, set the brakes, lower into field position, relieve the hydraulic fluid pressure, shut off the engine and **remove the ignition keys**.
- **Always** use safety support and block the wheels. When performing maintenance, never use a jack to support the machine. Assist the jack with blocks or other adequate support.
- Use extreme caution when making adjustments.
- When disconnecting hydraulic lines, shut off hydraulic supply and relieve all pressure.
- Never use hands to locate a hydraulic leak on attachments. Use a piece of cardboard or wood. Hydraulic fluid escaping under pressure can penetrate the skin.
- Openings in the skin and minor cuts are susceptible to infection from hydraulic fluid. **If injured by escaping hydraulic fluid, see a doctor at once. Gangrene can result. Without immediate medical treatment, serious infection and reactions can occur.**
- When installing, replacing, or repairing hydraulic system cylinders or parts, make sure that the entire system is charged and free of air before resuming operations. Failure to bleed the system of all air can result in improper machine operation, causing severe injury.
- After servicing, be sure all tools, parts, and service equipment are removed.
- Never replace hex bolts with less than grade five bolts unless otherwise specified.
- Where replacement parts are necessary for periodic maintenance and servicing, genuine factory replacement parts must be used to restore your equipment to original specifications. The manufacturer will not claim responsibility for damages as a result of the use of unapproved parts and/or accessories.
- If equipment has been altered in any way from original design, the manufacturer does not accept any liability for injury or warranty.

MAINTENANCE AND SERVICE SCHEDULE

- Prior to each use, check for loose bolts and replace lost or worn parts.
- Grease hinge pins before each use when necessary.
Note: Clean grease fittings and replace those that are broken or missing.
- Inspect and repack wheel bearings at the beginning of each year.
- Remove dirt and debris from the harrow sections before storage.
- Parts diagrams and listings for service and repair references may be found in appendix B.

OPERATING SUGGESTIONS

There are some important points to remember in order to obtain the best possible results from your McFarlane harrow.

- To maximize the harrow's performance, it should be towed at speeds ranging from six to nine (6 - 9) mph. This keeps the field debris moving through the harrow sections and avoids clogging. The best results will be obtained after the paint has been scoured from the teeth.
- Choose the angle of attack of the harrow teeth based on field conditions. For more information, see the section titled Angle of Attack.
- Getting the unit ready for transport includes the following steps:
 1. Rotate the harrow sections up.
 2. Swing the wings forward and lock them into the wing rests.
- Getting the unit ready for field use includes the following steps:
 1. Unlock the wings from the wing rests and swing the wings out.
 2. Rotate the harrow sections down while slowly moving forward, so that the sections lay out behind the unit properly.
- If the wing cables are not tight, adjust the attachment point to the Main Frame to tighten them. Follow the instructions in the section titled Attach the Wing Cables.

ASSEMBLY SUGGESTIONS

- You will find the machine is easier to assemble if the set-up instructions are followed in the order given in the manual.
- Before beginning, sort the various bolt bags, hardware bags and hydraulic bags according to what part of the unit that is being setup. Refer to the end of the parts listing in appendix B. Only open the bag or bags that are required as the setup instructions are followed.
- Whenever the terms “left” and “right” are used, it should be understood to mean when standing behind and facing the unit. This is also known as the “driver’s left” and the “driver’s right.”
- The term “field position” refers to the position the harrows are in when the unit is being used in the field - that is, with the wings out and the harrow sections down.
- The term “transport position” refers to the position the harrows would be in when the unit is being transported from place to place - that is, with the harrows up and the wings folded and secured in the wing rests.
- When assembling this unit, make sure that the parts are securely held before proceeding to the next step.
- Bolt torque specifications are given in appendix A.
- The hydraulic cylinder and hose requirements are listed in the parts listing in appendix B. It is not recommended that other size cylinders or hoses be substituted. Hoses are marked with the part number near the ends. The last three digits indicate the hose length in inches. Fittings with a restrictor are marked with an ‘R’.
- A dual acting hydraulics supply is required.
- Tire requirements are also listed in the parts listing in appendix B.
- Layout diagrams for each unit may be found in appendix C. Mark the page with the diagram that refers to your unit, it will be referred to periodically throughout the manual.

STEP - BY - STEP ASSEMBLY INSTRUCTIONS

Main Frame Assembly

1. Bolt the Hitch Tube to the Main Frame using 1 x 8 bolts and lock nuts. Note that there are different positions for the Hitch Tube.
2. Insert the Hub and Spindle into the Main Frame and secure using $\frac{1}{2}$ x 3 $\frac{1}{2}$ bolts and lock nuts. Install the 11L tires.
3. Attach the jack to the front of the Main Frame.

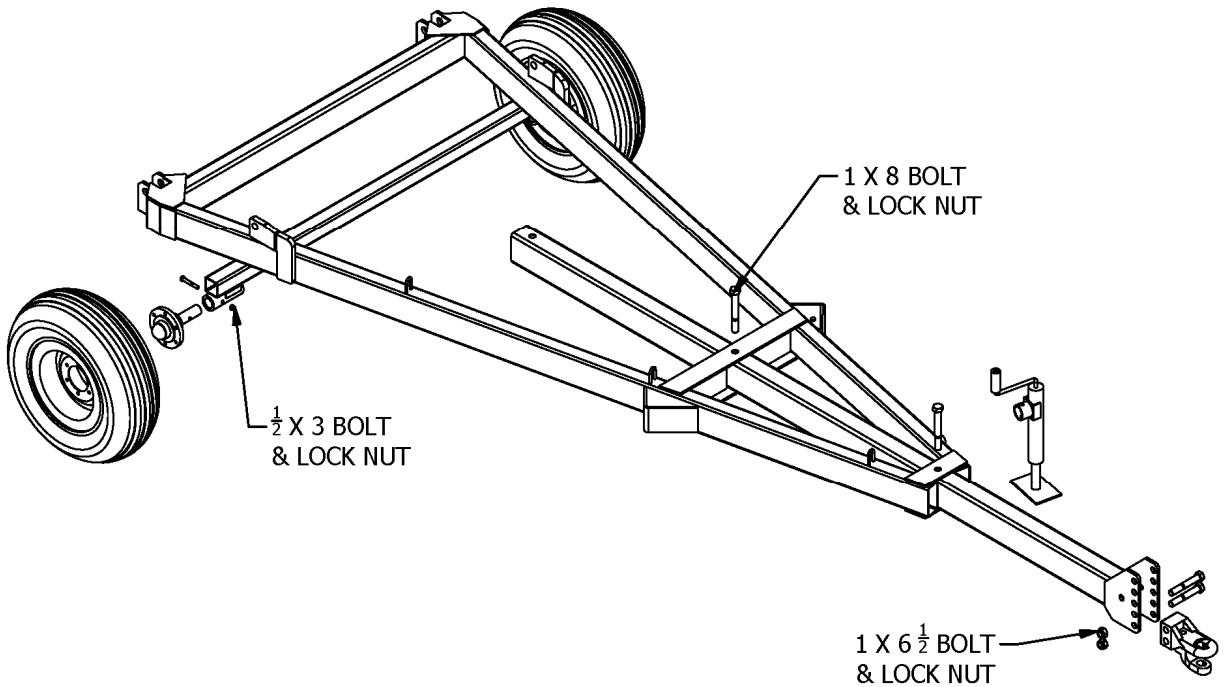

Figure 1

4. Assemble either a clevis hitch (figure 2) or a pintle hitch (figure 3) as required by the tractor or towing vehicle. Note the opposite orientation of the base hitch for each hitch type. Attach the hitch assembly to the Main Frame with two 1" x 6 $\frac{1}{2}$ " bolts and locking nuts.

Note: Parts have been provided to assemble a clevis hitch or a pintle hitch. Not all the included parts will be needed to assemble either type of hitch. Be sure to store the extra parts in a safe place; they will be needed if one requires the use of the other hitch type.

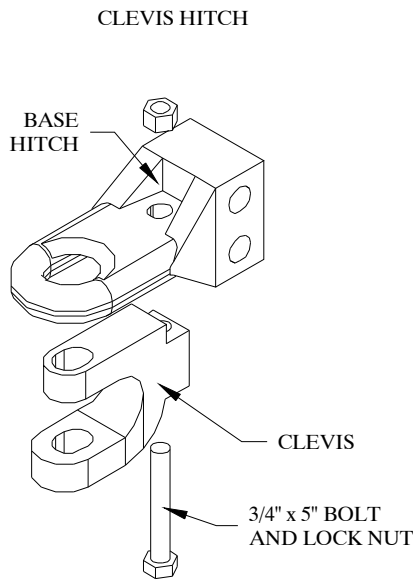

Figure 2

OR

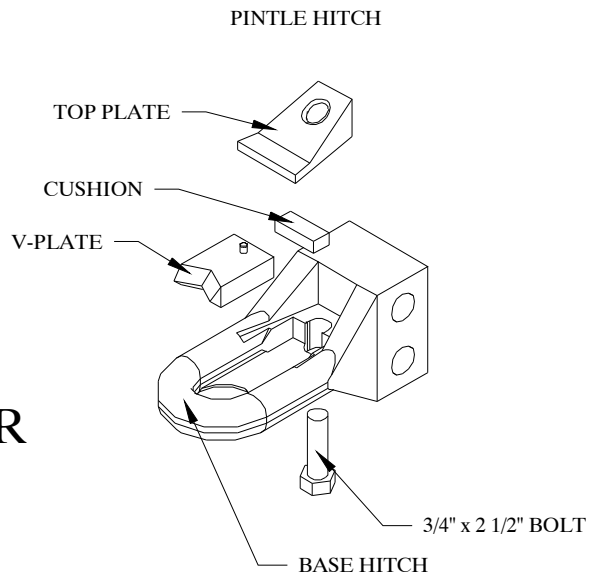

Figure 3

Attach the Center Bar

1. Attach the Center Bar to the Main Frame using 1 1/4 x 5 1/2 bolts and nylon jam nuts. Install the 4 x 8 cylinders as shown. Note that the 116 through 130 models are not trussed.

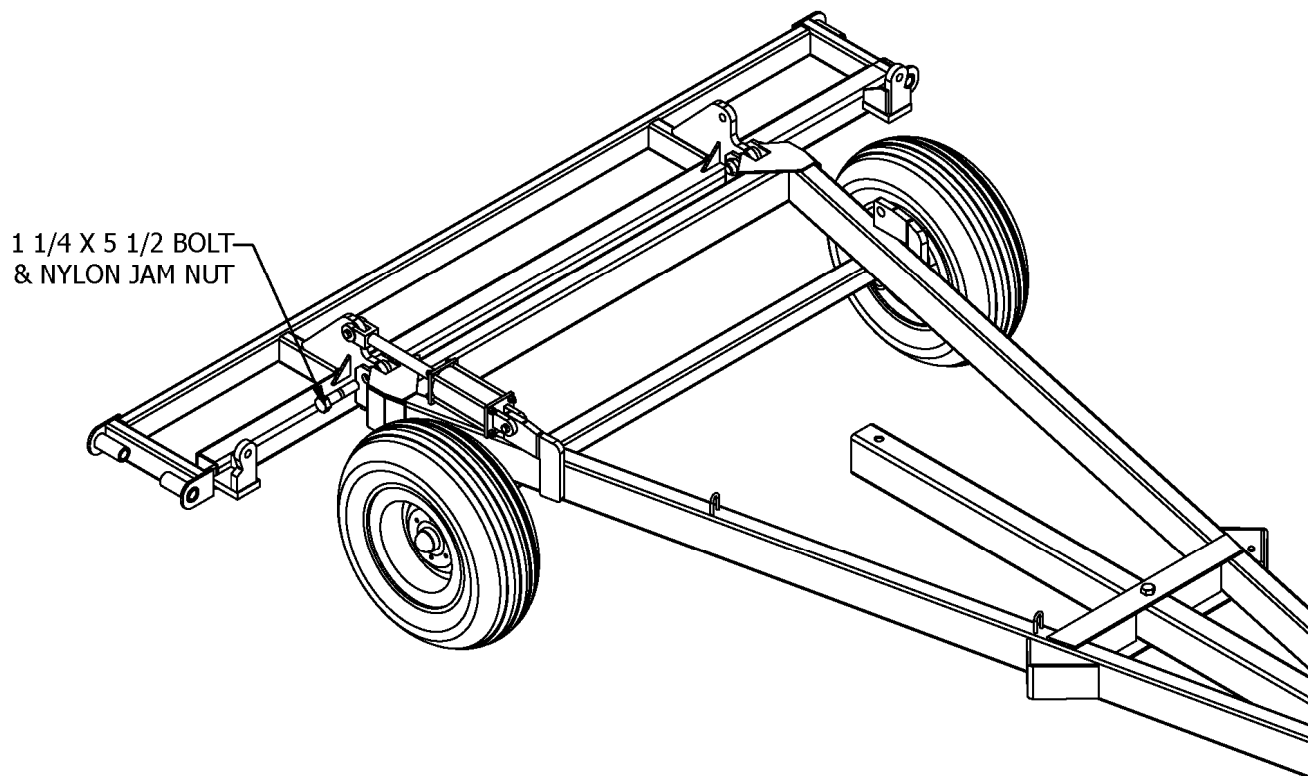

Figure 4

Attach and Assemble the Wing Frame

1. Attach the Wing Frame to the Center Bar using the 1 ¼ Hinge Pins and ½ x 3 bolts and lock nuts.
2. Insert a Hub and Spindle into the tube on the end of the Wing and secure using a ½ x 3 ½ bolt and lock nut. Install the 9.5L tires.
3. Attach the 14” cylinders between the Center Bar and Wing Frame, making sure the ports face towards the front of the unit. Note that the 116 through 130 models are not trussed.

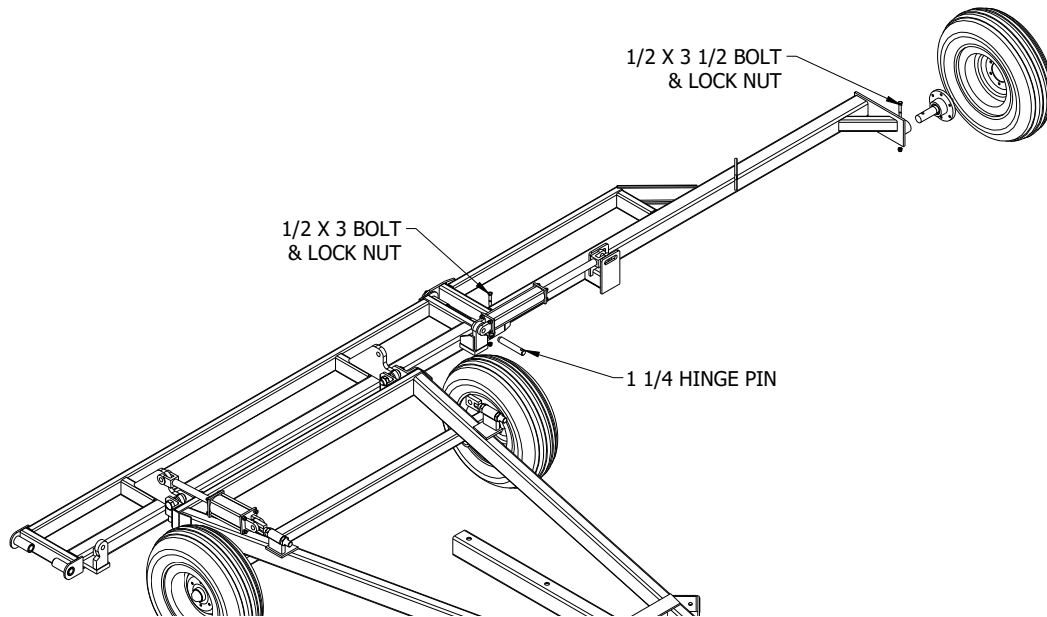

Figure 5

Install the Hydraulics System

Refer to the hydraulic system diagram in appendix B for details. For each step, refer to the diagrams for correct orientation.

1. Insert a male tee (o-ring fitting in center position) into both ports on the 4 x 8 cylinders on the right side of the Main Frame. Insert a tee (one female position) into both of the tees just installed.
2. Insert a male tee (o-ring fitting in side position) into both ports on the 4 x 8 main lift cylinders on the left side of the unit.
3. Insert a male elbow (with restrictor) into both ports of each 14” wing fold cylinders.
4. Attach two 43” (116 through 130 models) or 57” (132 through 140 models) hoses from both ports on one 4 x 8 cylinder to the other one.
5. Attach two 63” (116 through 130 models) or 80” (132 through 140 models) hoses from the base end of the 4 x 8 cylinders to the base end of the 14” wing fold cylinders.
6. Attach two 69” (116 through 130 models) or 90” (132 through 140 models) hoses from the rod end of the 4 x 8 cylinders to the rod end of the 14” wing fold cylinders.

7. Attach the 265" (116 through 122 models), 312" (124 through 130 models) or 360" (132 through 140 models) to the rod end of the 4 x 8 cylinder on the right hand side of the unit. Attach the 276" (116 through 122 models), 324" (124 through 130 models) or 372" (132 through 140 models) hose to the base end. Run both hoses to the hitch.
8. Secure all hoses to the frame to prevent damage between moving parts or from contacting the ground.

Attach the Lift Arms

1. Refer to the appropriate layout diagram in appendix C. Note the dimensions for the lift arm locations. Place a mark on the center bar and wings at the locations for each of the lift arms. Be sure the dimensions are for your unit.
2. Center a lift arm on each of these marks and secure using 5/8 x 6 bolts and lock nut.
3. Bolt a 6-link chain to the front pull point using a 1/2 x 1 3/4 bolt and lock nut. Note that some location may require a skew extension. See the next step for assembly instructions.
4. Attach the brace angles as shown using 7/16 x 1 1/4 bolts, flat washers and lock nuts.
5. Do Not bolt the rear lift chain on. Refer to this figure only after the rear lift chain has been attached to the section as shown in figure 9.

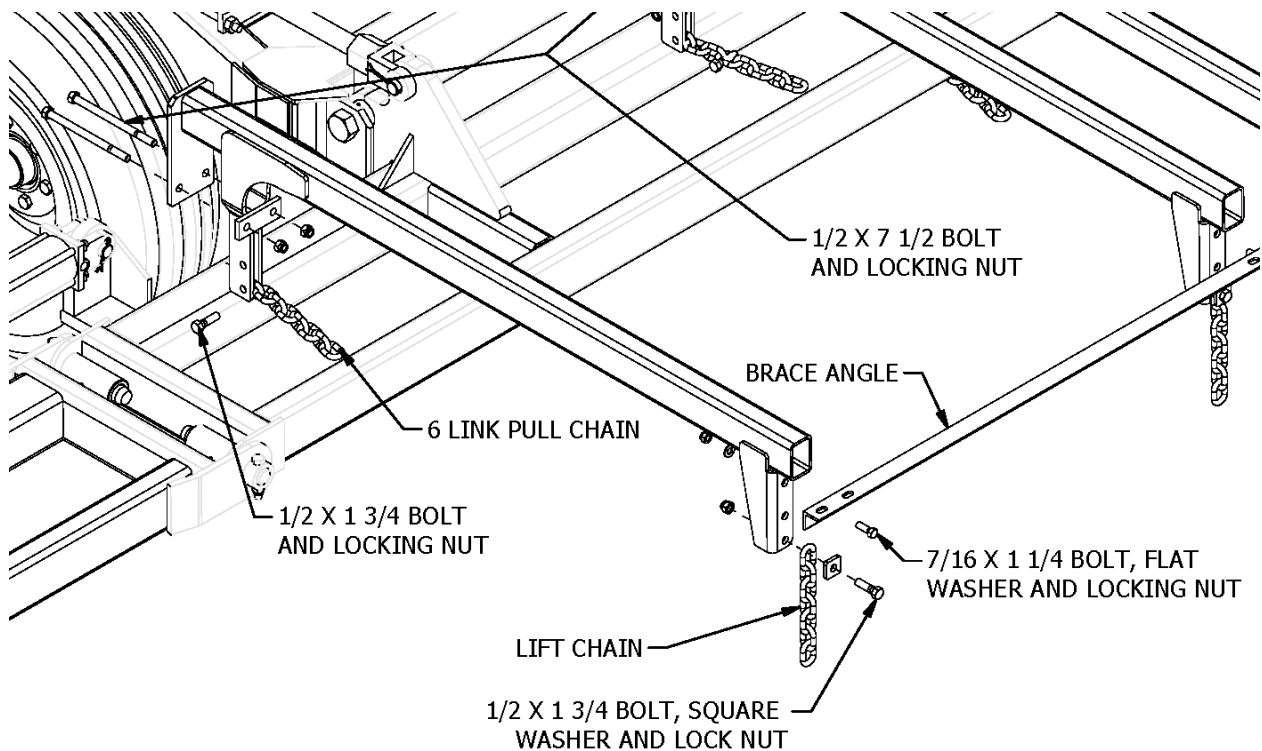

Figure 6

Attach the Pull Tubes

1. Refer to the layout diagram in appendix C and place the pull tubes behind the pull points. Bolt them to the pull chains using a 1/2" x 1 1/2" bolt, lock washer and hex nut for each pull chain.

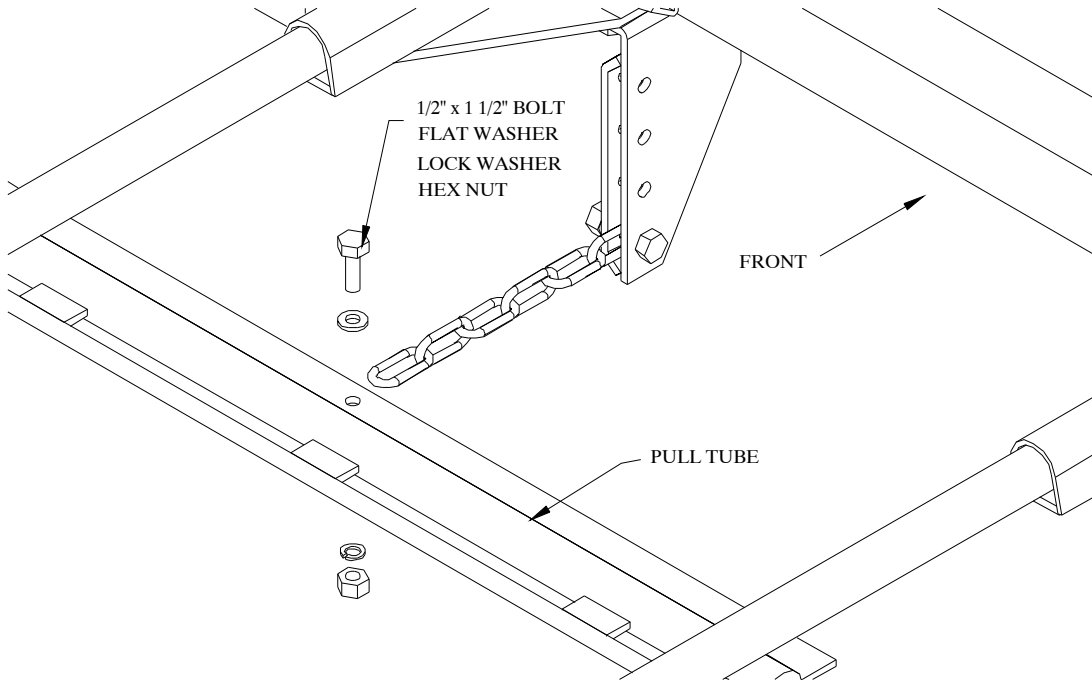

Figure 7

Attach the Front of the Harrow Sections

1. Hook the hooks on the front of the harrow sections between the pull tubes main tube and rear pull rod. Refer to the diagram in appendix C for harrow section placement.

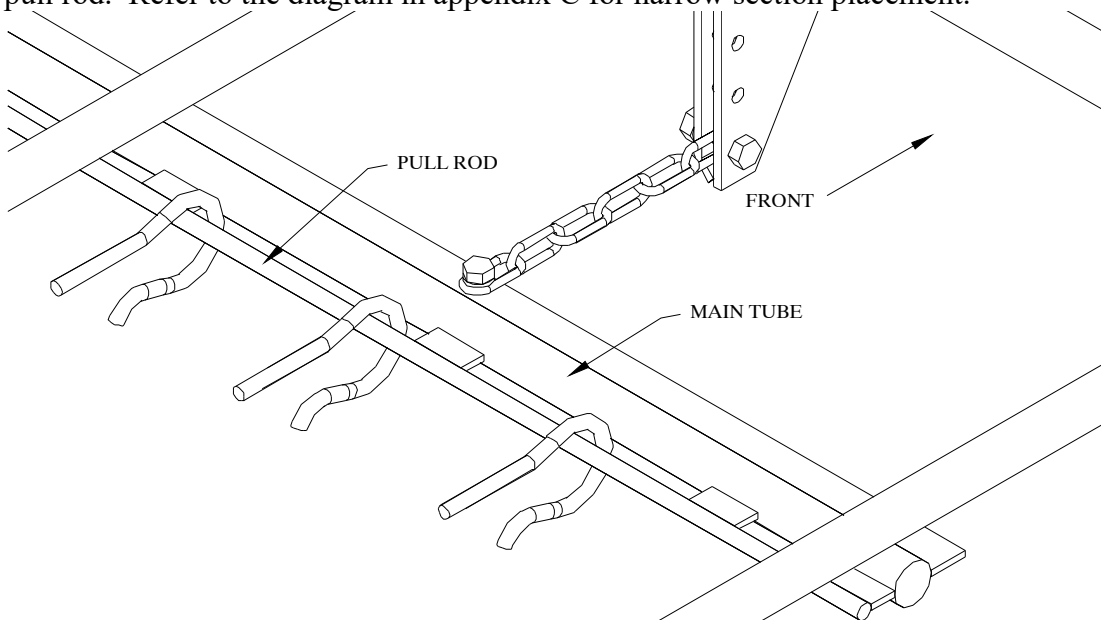

Figure 8

Attach the Lift Chains

1. Refer to figure 18 below. Wrap the 16-link lift chains around the second to last cross piece below and in front of the end of the lift tube and feed the chain back through the large 1-1/2" ring at the end of the chains.
2. Bolt the free end of the chain to the rear lift point using a 7/16 x 1 3/4 bolt, square washer, flat washer and lock nut. The square washer goes between the bolt head and the chain. Refer to figure 6 above.

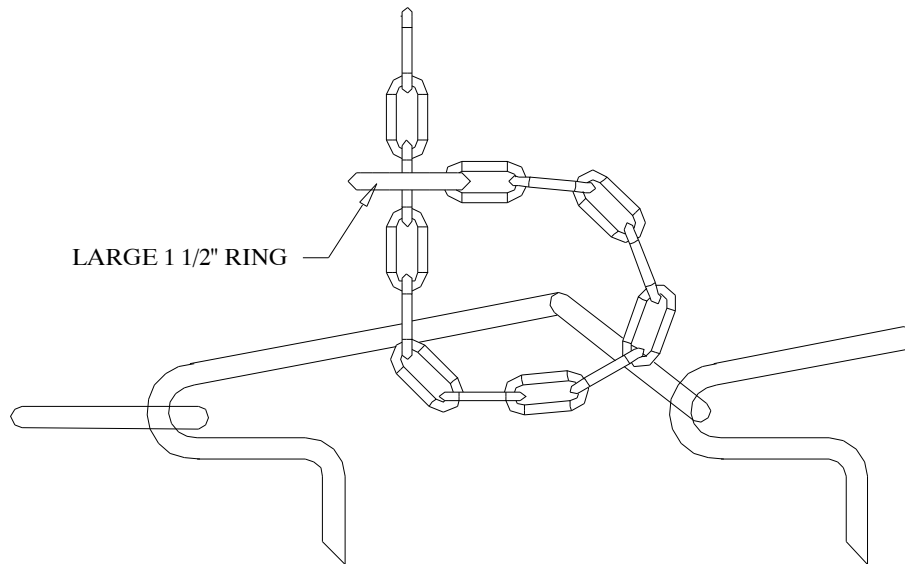

Figure 9

For the next steps you will need enough room to lower both wings completely. **Be sure the unit is attached to a tractor of adequate size before actuating the hydraulics!**

Attach the Wing Cables

1. Attach one end of the Wing Cable to the 5/8 x 8 eye-bolt with a shackle. Secure the eye-bolt to the bracket on the Main Frame with lock nuts.
2. Attach the Wing Cable to the Wing Cable Pull Brackets using the shackle.
3. Attach the Wing Cable Pull Brackets to the wings using the 5/8-11 x 4x 5.5 U-Bolts and the 5/8-11 Top Lock Nuts. Be sure to pull the Wing Cable tight.
4. Adjust the Eye Bolt so that the cables are tight.

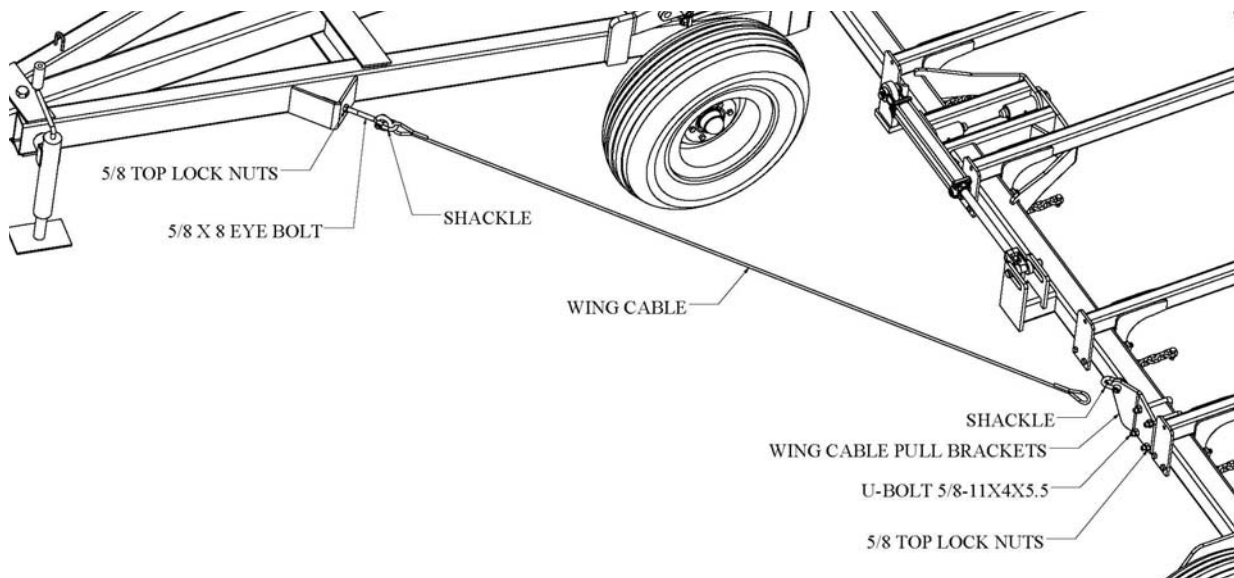

Figure 11

Attach the Wing Cable Lift Assembly

1. Bolt the Cable Lift Bracket to the Main Frame approximately 24" from the front of the frame side tube. Use two ½ x 3 x 7 U-bolts and lock nuts. Do *not* tighten yet.
2. Bolt the Cable Lift Angle to the Cable Lift Bracket. Use the 5/8 x 4 bolt and lock nut.
3. Attach the Cable Lift Spring to the tabs on the Cable Lift Bracket and the Cable Lift Angle by placing a lock clip on each end of the spring. Use 7/16 x 1 ½ bolts and lock nuts to fasten the lock clips and spring to the tabs.
4. Attach the ¼ x 15-link lift chain to the Cable Lift Angle with a small shackle.
5. Adjust the assembly so that the chain on the Cable Lift Angle hangs directly above the cable when the cart is in the field position and the cable is pulled tight.
6. Using a small shackle, attach the lift chain to the Wing Cable.
7. Rotate the wings into the transport position. If the cables are touching the ground, the cable lift bracket assembly needs to be moved until the cable is clear of the ground. When properly adjusted, tighten all bolts.

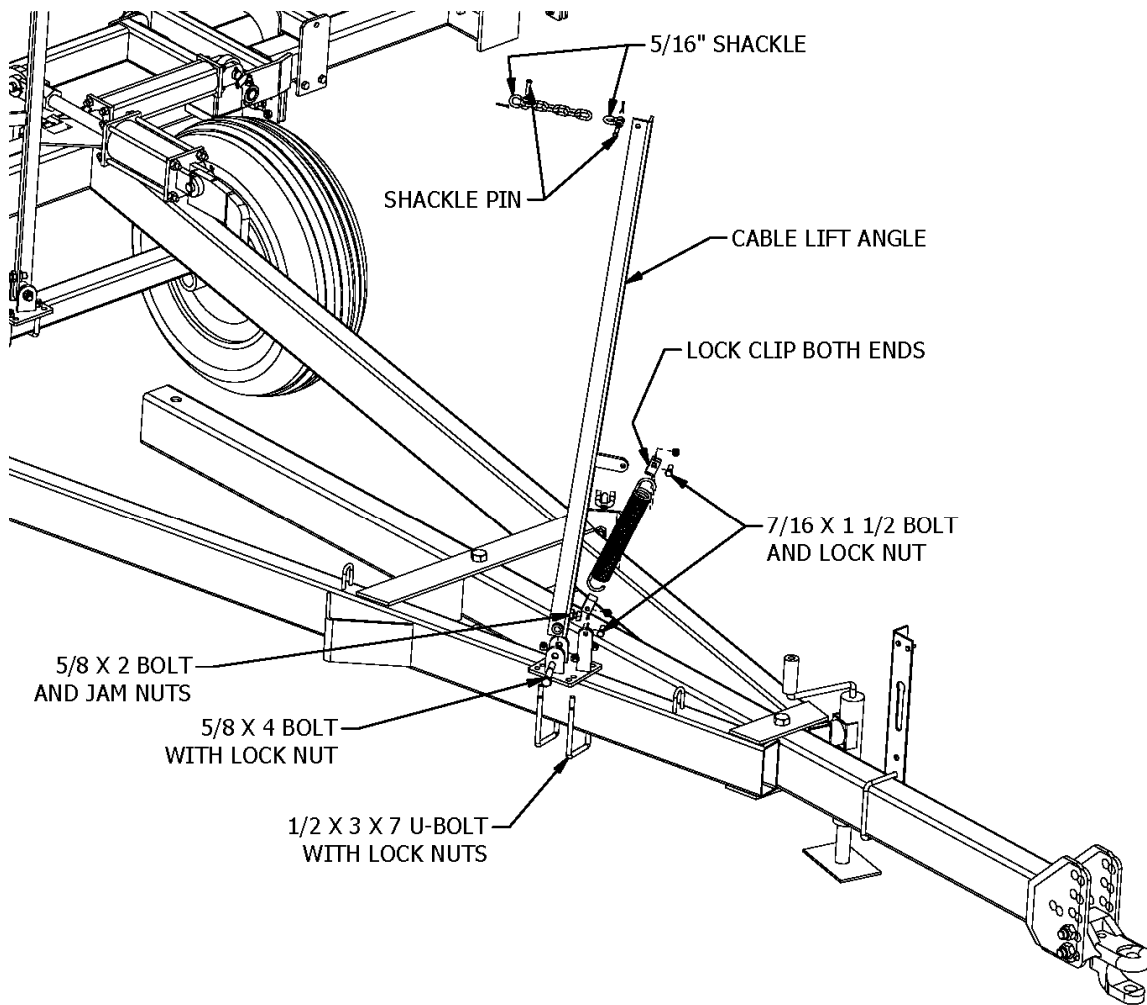

Figure 12

Attach the Wing Rests

1. Place the Wing Rests approximately 18" ahead of the cylinder post on the Main Frame. Bolt firmly in place using the 5/8 x 6 x 4 U-bolts and lock nuts. Do *not* tighten yet. Refer to Final Adjustments step 2 regarding Stroke Control Collar and Wing Rest location adjustments.

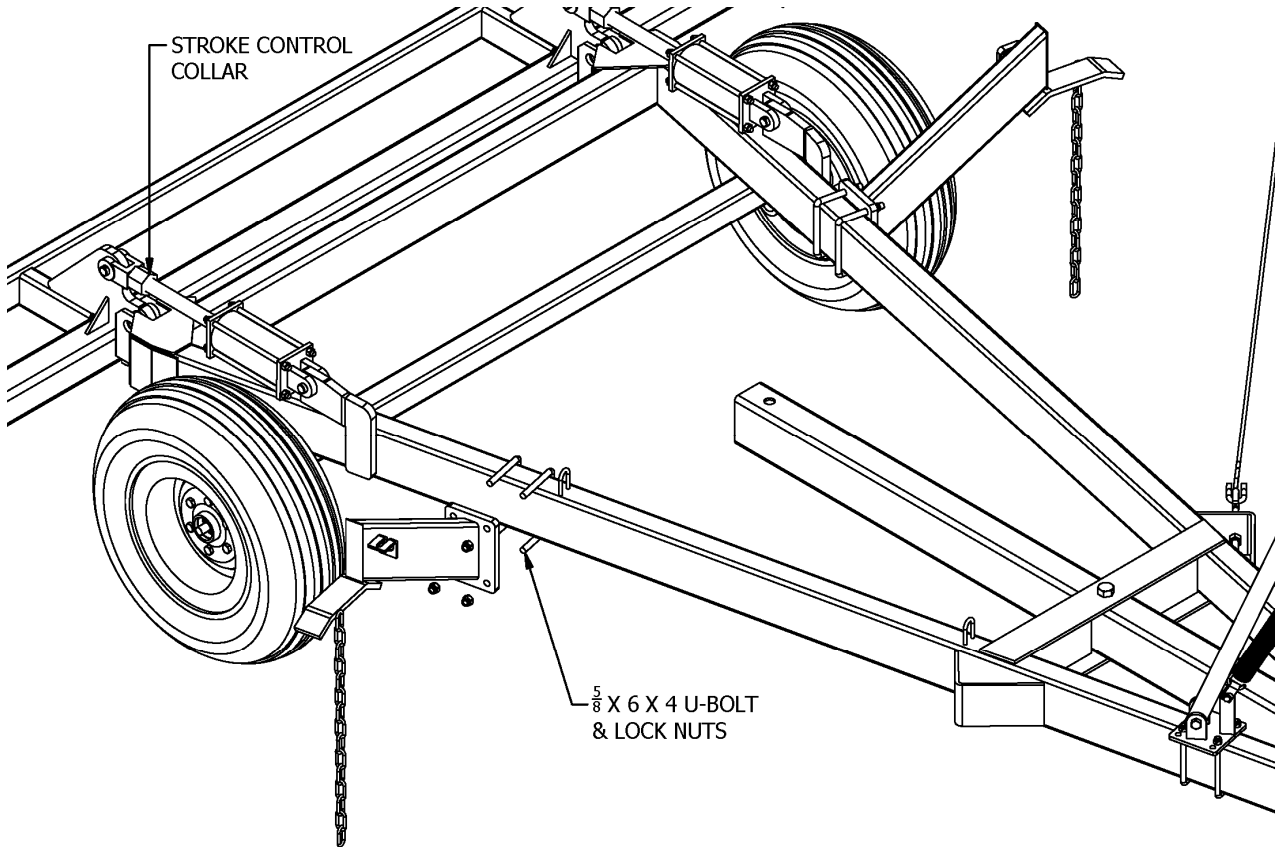

Figure 13

Install the Lighting Package

1. With the unit in field position, lay out the wire harness wishbone. The wishbone has a four pin plug in the middle of it and is split with three pin plugs on each end. The three pin plug connects to the lights. Lay the wishbone out on the tool bar, following across to the first lift arm of each wing. Do not attach to the frame yet.
2. Lay out the wire harness extension with the seven pin connector. Start by plugging it into the wire harness wishbone that is laid out on the tool bar. Work towards the hitch, following along the center bar tube to the main lift hydraulic cylinder and then along the hydraulic hoses up to the main frame as shown in the diagram. Do not attach yet. Make sure there is plenty of slack to connect to the towing vehicle. The wire harness may need to be pulled towards the hitch and the rear connection point moved to one side.
3. If the lights are not already mounted into the mounting brackets, attach them now using the 1/4 x 1 1/4 bolts, flat washers, lock washers and hex nuts.

4. Attach the light assemblies to the first lift arm on the wings using the 3/8 x 2 – 3 3/4 U-Bolts, lock washers and hex nuts. Do not tighten yet. You may have to adjust the location later. The lights must be attached so that the red and yellow lens will be facing towards the center of the unit with the yellow light towards the rear of the unit. The single yellow lens will be facing away from the center of the unit. Connect the free end of the wishbone to the lights.
5. Now that the lights have been mounted and the wires run, attach wire harnesses to the frame and hydraulic hoses with zip ties. Be sure to leave slack at the hinge points to prevent the wire harness from becoming entangled. Also, securely attach the wire harness to the lift arm and next to the light assembly.
6. Tighten the light assemblies to the lift arms.
7. Check to make sure that all the plugs are properly and securely connected and the wire harnesses will not become entangled during operation or when the unit is folded into transport position.
8. Attach the unit to a tractor and plug in the lights. Check to make sure that they are working properly and that the wires do not pull or get caught when folding the unit into the transport position. With the unit in transport position, the red and yellow lights should be visible from the rear. The red light should be closest to the ground.

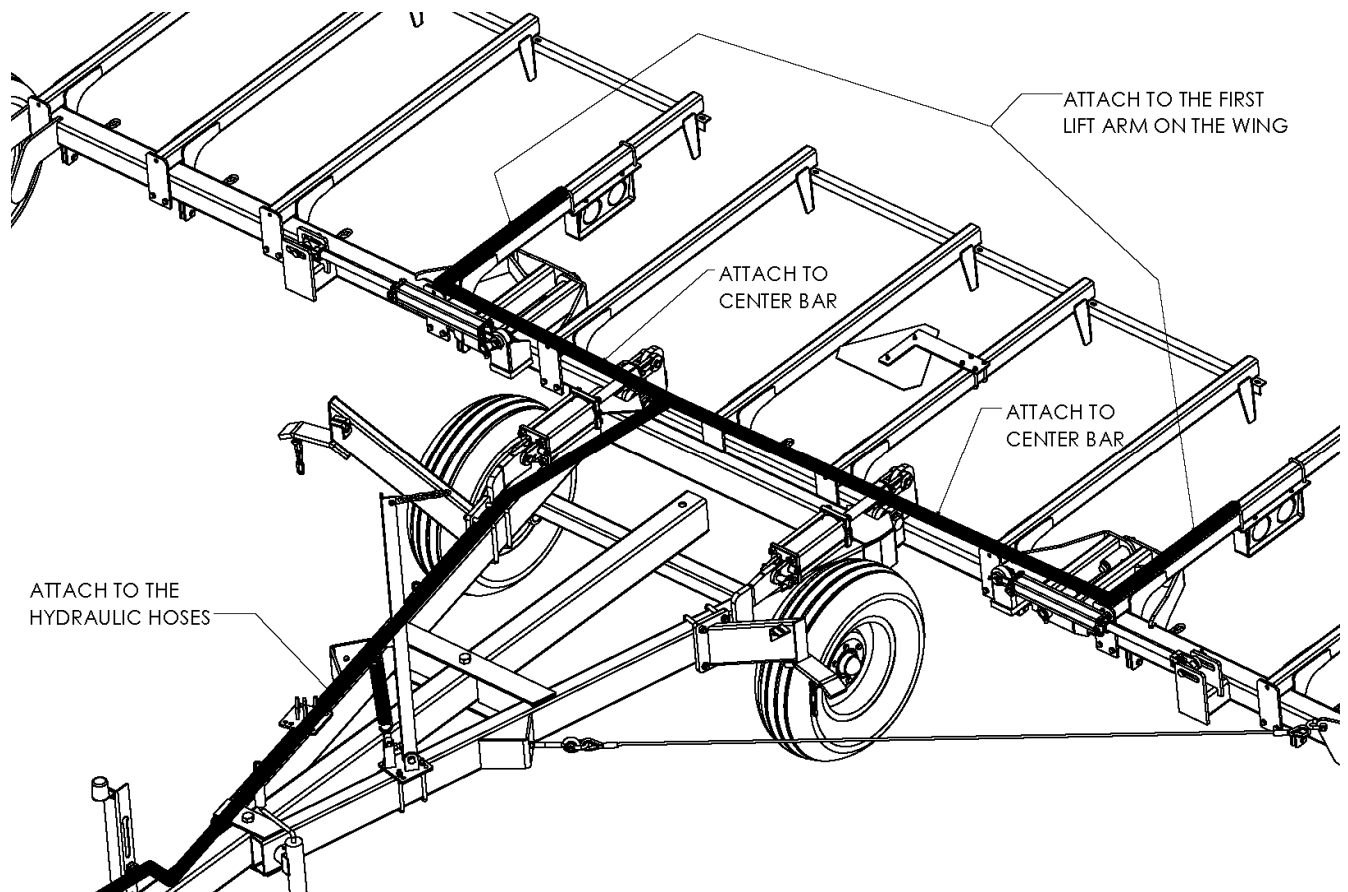

Figure 14

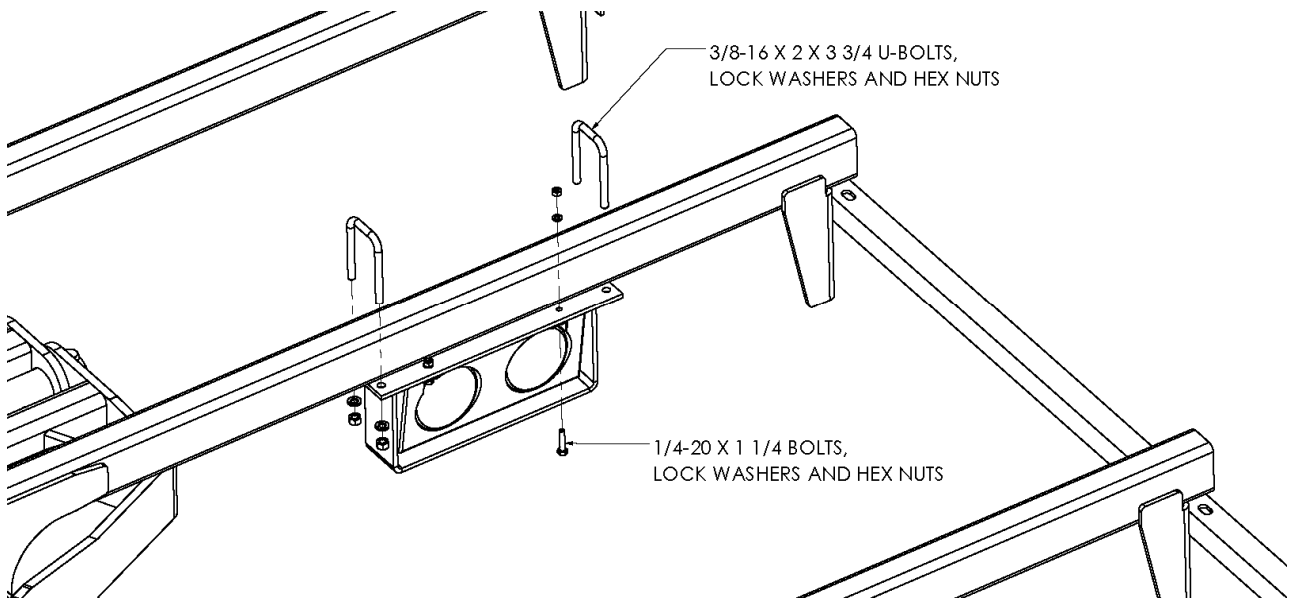

Figure 15

Attach the Hitch Storage Bracket

1. Attach the Hitch Storage Bracket (4) to the front of the Hitch Pole using the 1/2 x 6 U-bolt (1), lock washers (2) and nuts (3). Attach the Light Plug Storage receptacle (8) using 1/4 x 1 bolts (5), lock washers (6) and nuts (7).

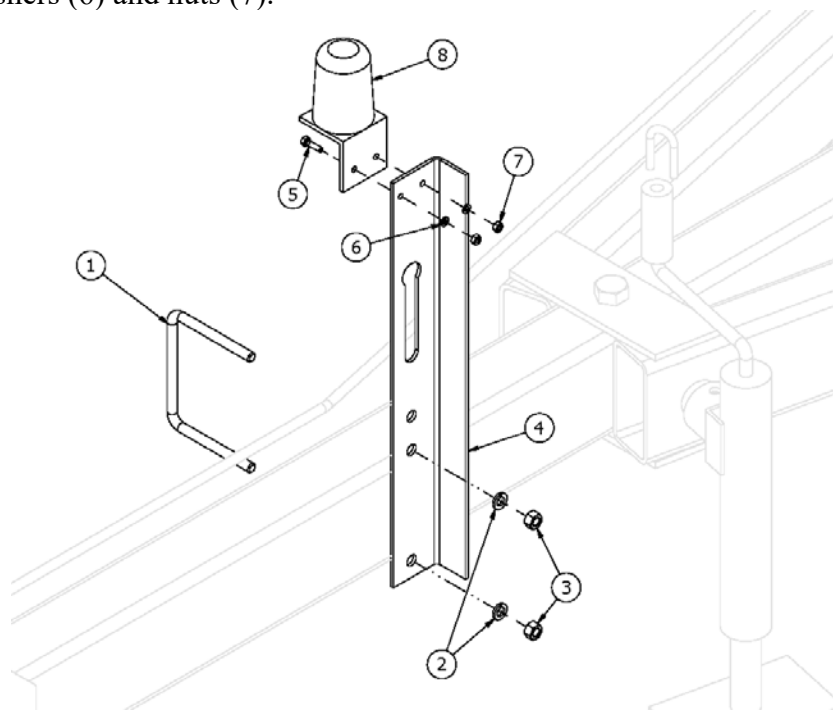

Figure 16

Attach the Slow Moving Vehicle sign

1. Attach the SMV sign Mounting Bracket (1) to the first lift arm left of center as shown in Figure 16, using 3/8 X 2 X 3 3/4 U-bolts (2) and locking nuts (3). Attach the SMV sign (4) to the Mounting Bracket (1) using 1/4 x 1 bolts (5), and locking nuts (6).
When the unit is folded in transport position, be sure the SMV sign is aligned between the harrow section bars so that it is visible from the rear.

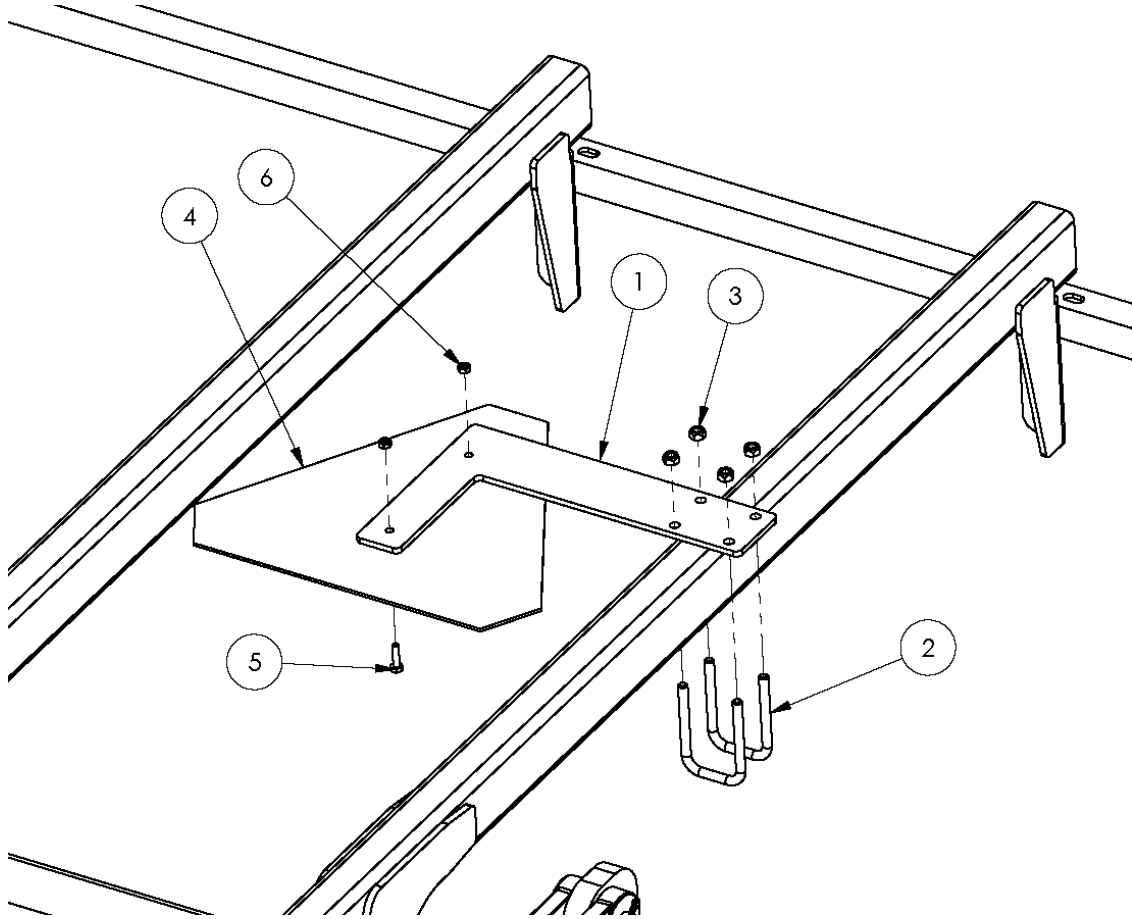

Figure 17

Final Adjustments

1. Unfold the unit into the field position and fully extend all cylinders.
2. Slowly fold the unit into the transport position. Be sure the Wing Frames engage the ramp on the Wing Rest and fully sit on it. It may be necessary to adjust the Wing Rest back/forward. It may also be necessary to adjust the stroke control collar on the 4x8 main lift cylinders. If the wings are too low, extend the collar until the wings engage the Wing Rest ramp and secure the lock collar with the snap ring.
3. Unfold the unit into field position and pull the completed unit ahead a few feet to check that everything is properly assembled and that nothing is binding or misaligned. Check to make sure that all fasteners are tight.
4. Be sure to wrap the chains around the wing tubes for security during transport.
5. With the unit in the transport position, attach the red and amber reflectors at the widest visible points. The red reflectors should be visible from the rear of the unit, and the amber reflectors should be visible from the front of the unit.
6. Do not detach the unit from the tractor unless the jack stand is down and the wings are secured in the wing rests.
7. After the first few hours of operation, check all fasteners and tighten if necessary. Include wheel lugs.

This completes the assembly of your harrow and transport cart. Before using the unit, double check that all components have been assembled properly. If there are any questions regarding any of the assembly steps, contact your local dealer for an explanation. Do not operate this or any equipment unless you are sure that all components operate as they were designed to operate.

TROUBLESHOOTING

PROBLEM	POSSIBLE CAUSE	SOLUTION
Hydraulics actuate too rapidly	Hydraulic restrictors not installed	Install hydraulic restrictors
Wings will not slide into wing rests	Wing rests improperly positioned	Reposition wing rests
Excessive clogging during operations	Angle of attack too steep	Pull harrow sections from the other end
	Ground speed too low	Increase ground speed to 6 - 9 mph

BOLT TORQUE SPECIFICATIONS

Coarse Thread Series			Fine Thread Series		
Nut Size and Threads per Inch	Nut Tightening Torque (lb.ft.)		Nut Size and Threads per Inch	Nut Tightening Torque (lb.ft.)	
Grade C Nuts			Grade C Nuts		
	Max.	Min.		Max.	Min.
1/4 - 20	14.7	10	1/4 - 28	14.7	10
5/16 - 18	22.3	15.2	5/16 - 24	23.4	18.4
3/8 - 16	39	28	3/8 - 24	41	30
7/16 - 14	60	44	7/16 - 20	60	44
1/2 - 13	88	63	1/2 - 20	98	70
9/16 - 12	134	98	9/16 - 18	134	98
5/8 - 11	172	127	5/8 - 18	176	127
3/4 - 10	295	218	3/4 - 16	295	218
7/8 - 9	440	317	7/8 - 14	440	317
1 - 8	651	506	1 - 14	703	610

HUB AND TIRE SPECIFICATIONS

Tire Size	Play Rating	Tire Pressure	Lug Size	Lug Tightening Torque (lb.ft.)	
				Max.	Min.
9.5L-15	8	44	1/2"	90	80
11L-15	8	36	1/2"	90	80

HD-116 through HD-140 HARROW CART PARTS DIAGRAM

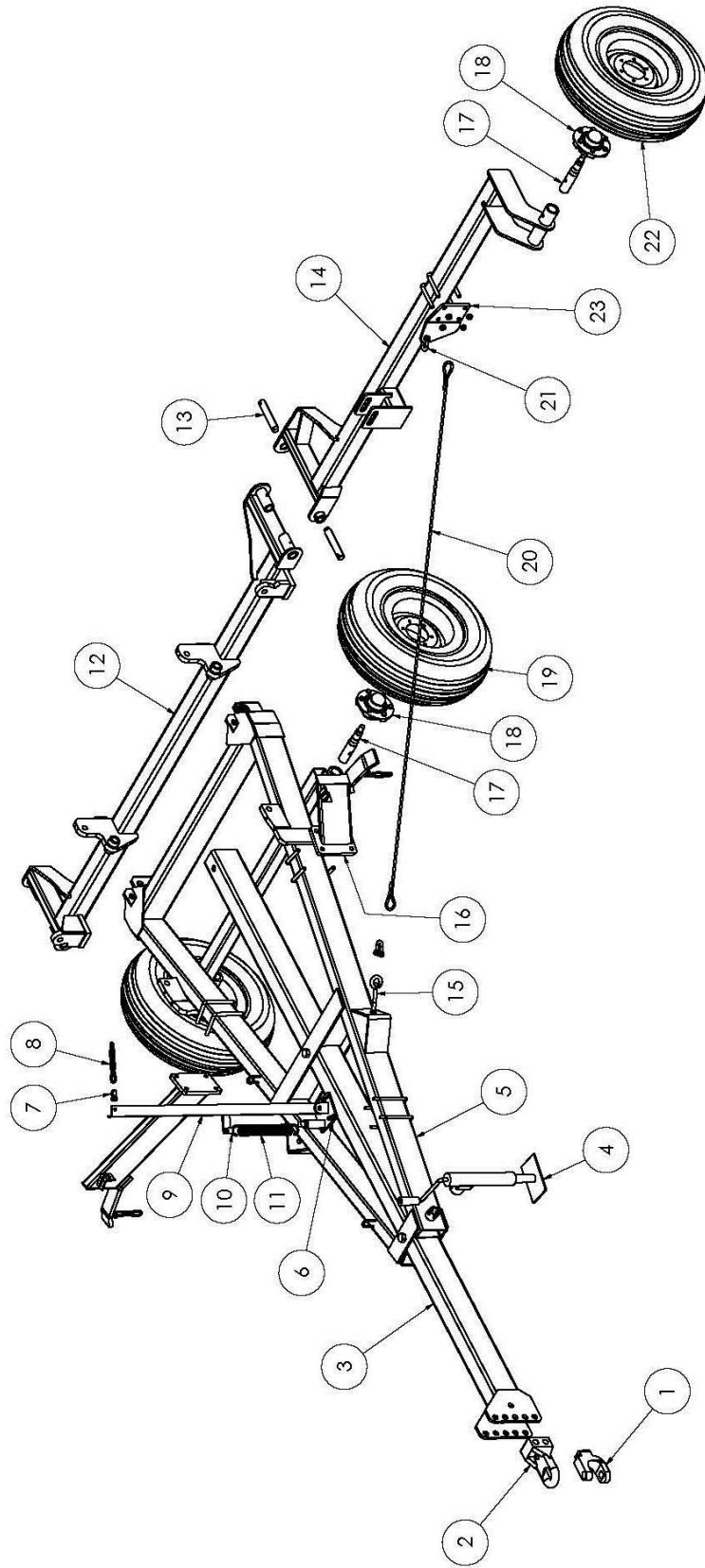

HD-116 through HD-140 HARROW CART PARTS LIST

Always order by Part Number - *Not* by Key Number

KEY	PART #	DESCRIPTION	QTY.
1	PPI-208	CLEVIS	1
2	PPI-300	BASE HITCH	1
**	HDL-201	HITCH POLE – 12' (116 – 122 models)	1
3	HDL-278	HITCH POLE – 16' (124 – 140 models)	1
4	HD-1151	JACK STAND (10")	1
5	HDL-227	MAIN FRAME	1
**	HDL-2540	CABLE LIFT BRACKET, RT	1
6	HDL-2541	CABLE LIFT BRACKET, LT	1
7	AL-030	5/16 SHACKLE	4
8	CH-1406	¼ X 6 LINK CHAIN	2
9	HDL-228	CABLE LIFT ANGLE	2
10	N-021	LOCK CLIP	4
11	PH-10	CABLE LIFT ARM SPRING	2
**	HDL-233	CENTER BAR (132 – 140 models)	1
12	HDL-230	CENTER BAR (116 – 130 models, non-trussed)	1
13	RT-2124	WING HINGE PIN – 1 ¼ X 7 ½	4
14	***	WING FRAME (note 116 – 130 modes are not trussed)	2
15	EB-5808	EYE BOLT, 5/8 X 8	2
16	HDL-2522	WING REST (LEFT HAND)	2
16	HDL-2529	WING REST (RIGHT HAND)	2
17	WDL-2505	MAIN FRAME AXLE SPINDLE	2
18	HD-1371	HUB (6-hole hub)	2
**	HD-1360	GREASE SEAL (6-hole hub)	2
**	HD-1362	INNER BEARING (6-hole hub)	2
**	HD-1361	HUB WITH RACES (6-hole hub)	2
**	HD-1363	OUTER BEARING (6-hole hub)	2
**	HD-1364	SPINDLE FLAT WASHER (6-hole hub)	2
**	HD-1365	SPINDLE HEX NUT (6-hole hub)	2
**	CP-1517	COTTER PIN	2
**	HD-1367	DUST CAP (6-hole hub)	2
19	11L-15 8T	MAIN FRAME TIRE	2
	HD-1368	RIM (15" x 8" 6-hole) for 11L-15 tire	2
20	WC-8105	WING CABLE	2
21	HDL-219	WING CABLE SHACKLE, 5/16	2
22	9.5L-15 8T	WING FRAME TIRE	2
	HD-1370	RIM (15" x 6" 6-hole) for 9.5L-15 tire	2
23	HDL-235	WING CABLE PULL BRACKET, LEFT	1
**	HDL-236	WING CABLE PULL BRACKET, RIGHT	1
**		Unnumbered items are not pictured.	
***		Please specify model number when ordering these parts.	

McFarlane Manufacturing reserves the right to change specifications of design at any time without obligation to modify previous products.

CHAIN HARROW SECTION LIFT ARMS PARTS DIAGRAM & LIST

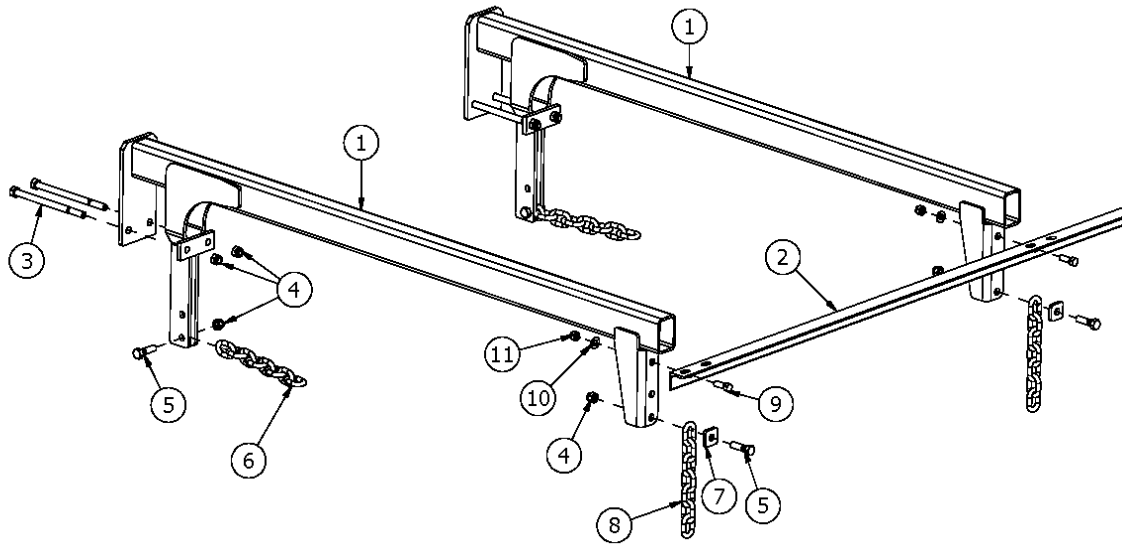

Always order by Part Number - *Not* by Key Number

KEY	PART #	DESCRIPTION	QTY.
1	HDL-237	CHAIN HARROW LIFT ARM	*
2	***	BRACE ANGLE	*
3	BH-5075	1/2 X 7 1/2 HEX BOLT	*
4	NLT-5013	1/2 LOCK NUT	*
5	BH-5018	1/2 X 1 3/4 HEX BOLT	*
6	CH-0706	7/0 X 6 LINK PULL CHAIN	*
7	HDD-016	1/2 SQUARE WASHER	*
8	CH-1516	16 LINK LIFT CHAIN W/RING	*
9	BH-4413	7/16 X 1 1/4 HEX BOLT	*
10	FW-0044	7/16 FLAT WASHER	*
11	NLT-4414	7/16 FLAT WASHER	*

* Quantity depends on harrow sections used.

** Unnumbered items are not pictured.

*** Please specify model number when ordering these parts.

McFarlane Manufacturing reserves the right to change specifications of design at any time without obligation to modify previous products.

HD-116 through 140 HARROW CART HYDRAULICS DIAGRAM & LISTING

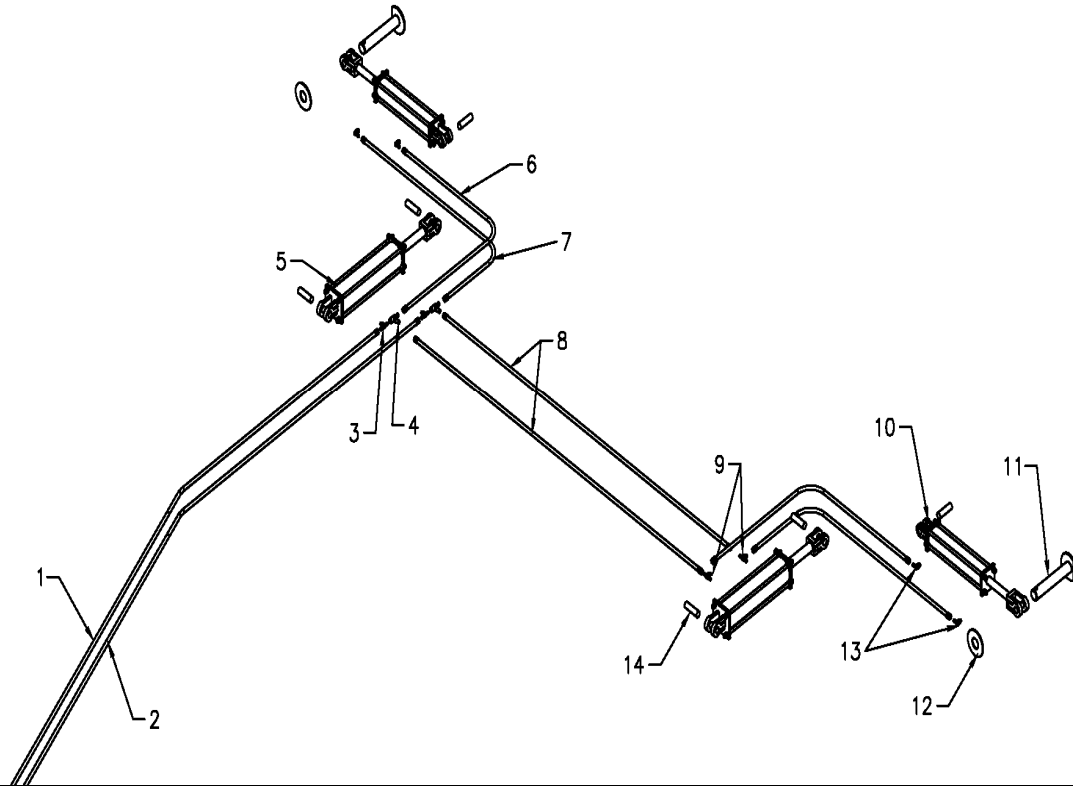

KEY	PART #	DESCRIPTION	QTY.
1	HYH-9265	3/8" X 265" HYD HOSE with one 1/2" end (116 – 122)	1
	HYH-9312	3/8" X 312" HYD HOSE with one 1/2" end (124 – 130)	1
	HYH-9360	3/8" X 360" HYD HOSE with one 1/2" end (132 – 140)	1
2	HYH-7276	3/8" X 276" HYD HOSE with restrictor (116 – 122)	1
	HYH-7324	3/8" X 324" HYD HOSE with restrictor (124 – 130)	1
	HYH-7372	3/8" X 372" HYD HOSE with restrictor (132 – 140)	1
3	HYF-1809	TEE (3/8"m – 1/2"o - 3/8"m)	2
4	HYF-1188	TEE (3/8"f – 3/8"m - 3/8"m)	2
5	HYA-4008	4 X 8 ASAE HYDRAULIC CYLINDER	2
6	HYH-8063	3/8" x 63" HYDRAULIC HOSE (116 – 122)	2
	HYH-8080	3/8" x 80" HYDRAULIC HOSE (132 – 140)	2
7	HYH-8069	3/8" x 69" HYDRAULIC HOSE (116 – 122)	2
	HYH-8090	3/8" x 90" HYDRAULIC HOSE (132 – 140)	2
8	HYH-8043	3/8" x 43" HYDRAULIC HOSE (116 – 122)	2
	HYH-8057	3/8" x 57" HYDRAULIC HOSE (132 – 140)	2
9	HYF-1089	TEE (1/2"o – 3/8"m - 3/8"m)	2
10	HYC-32014	2 X 14 HYDRAULIC CYLINDER	2
11	CL-1005	1" X 5" CLEVIS PIN	2
12	FW-0010	1" FLAT WASHER	4
13	HYF-2821	ELBOW (3/8"m – 1/2"o-ring) with restrictor	4
14	HYO-2103	1" x 3 1/2" CLEVIS PIN	8

HITCH STORAGE BRACKET

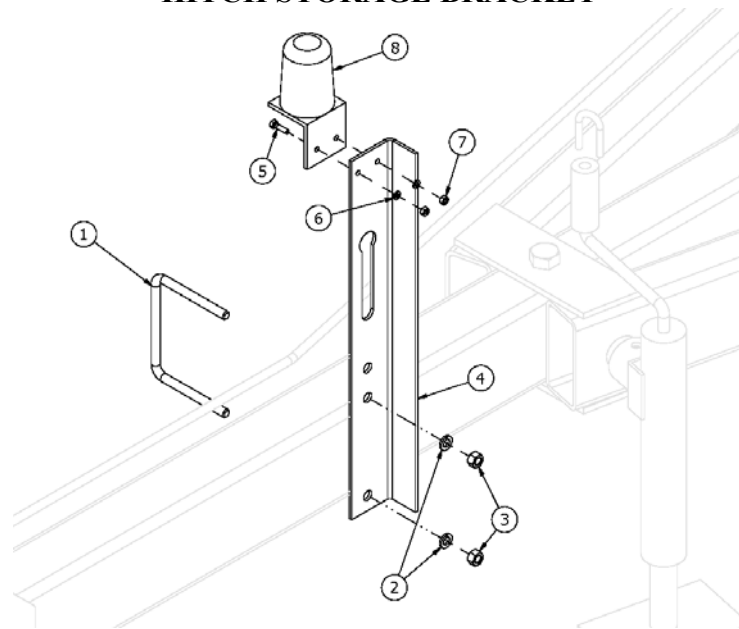

KEY	PART #	DESCRIPTION	NOTES
1	BU-1265	U-BOLT, 1/2" X 6 X 5	
2	LW-0050	1/2" LOCK WASHERS	
3	NH-5013	1/2" HEX NUT	
4	LB-1105	HITCH STORAGE BRACKET	
5	BH-2510	1/4" - 20 X 1 GRADE 5 HEX BOLT	
6	LW-0025	1/4" LOCK WAHSERS	
7	NH-2520	1/4" HEX NUT	
8	LB-1110	LIGHT PLUG STORAGE	

LIGHTING AND SMV COMPONENTS

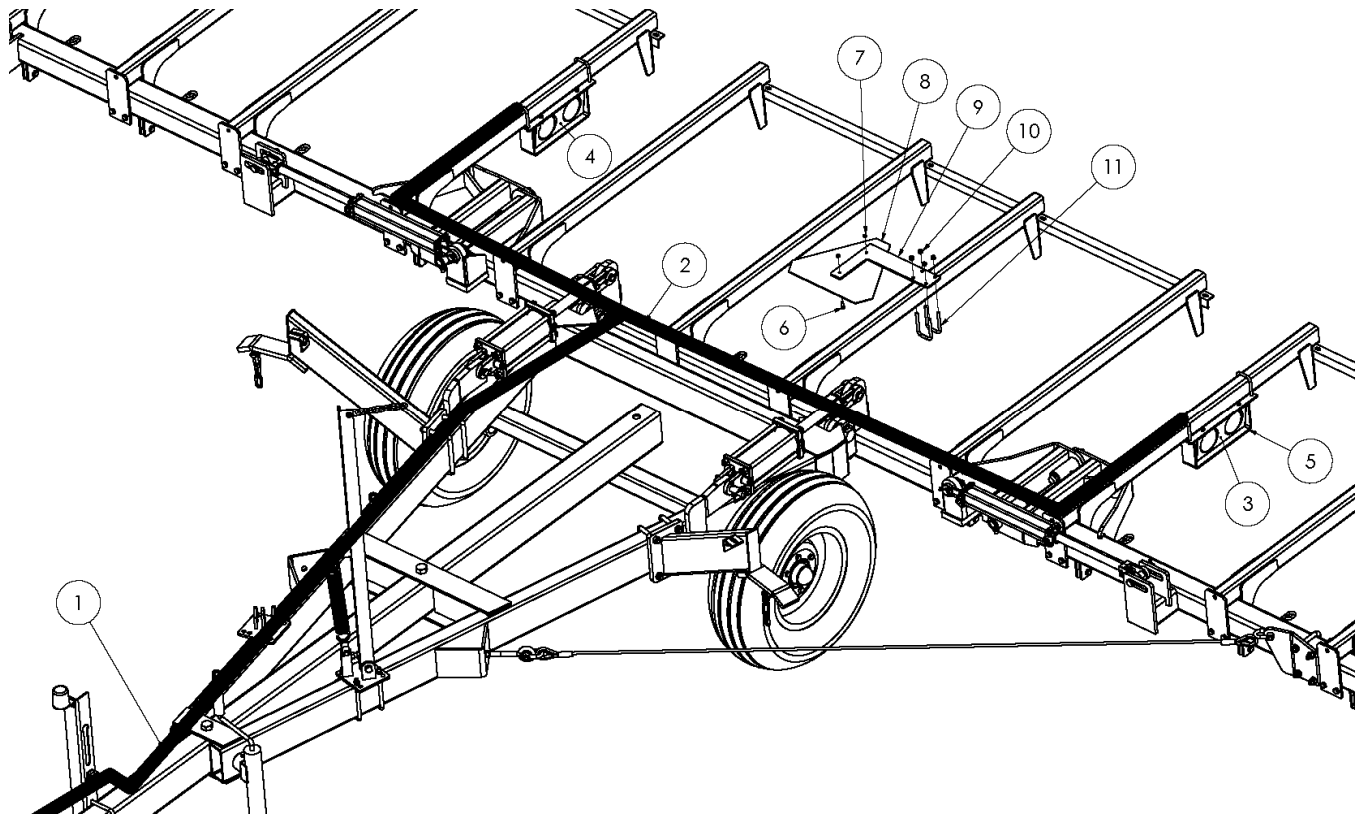

KEY	PART #	DESCRIPTION	QTY.
1	LB-1325	25' WIRE HARNESS EXTENSION	1
2	LB-1420	20' WIRE HARNESS WISHBONE (10' EACH DIRECTION)	1
3	LB-1101	LIGHT – LEFT HAND	1
4	LB-1101	LIGHT – RIGHT HAND	1
5	LB-1200	LIGHT BRACKET MOUNT	2
6	BH-2510	1/4 X 1 HEX BOLT	2
7	NLT-2520	1/4-20 TOP LOCK HEX NUT	2
8	MM-1300	SMV SIGN	1
9	LB-1207	SMV MOUNT BRACKET 2"	1
10	NLT-3816	3/8-16 TOP LOCK HEX NUT	4
11	BU-3824	U-BOLT, 3/8-16X2X3.75	2

HD-120-U LAYOUT DIAGRAM

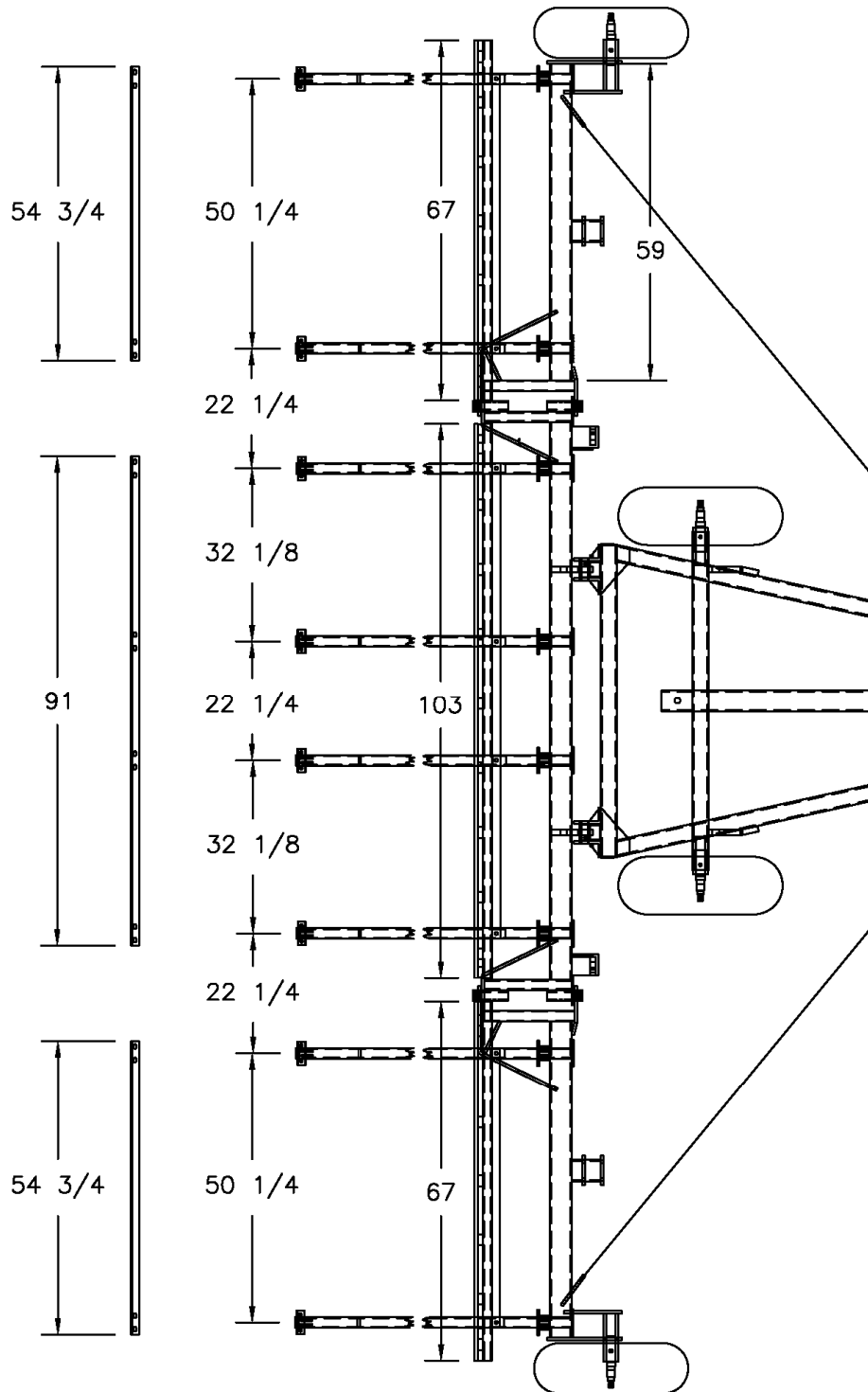

HD-124-U LAYOUT DIAGRAM

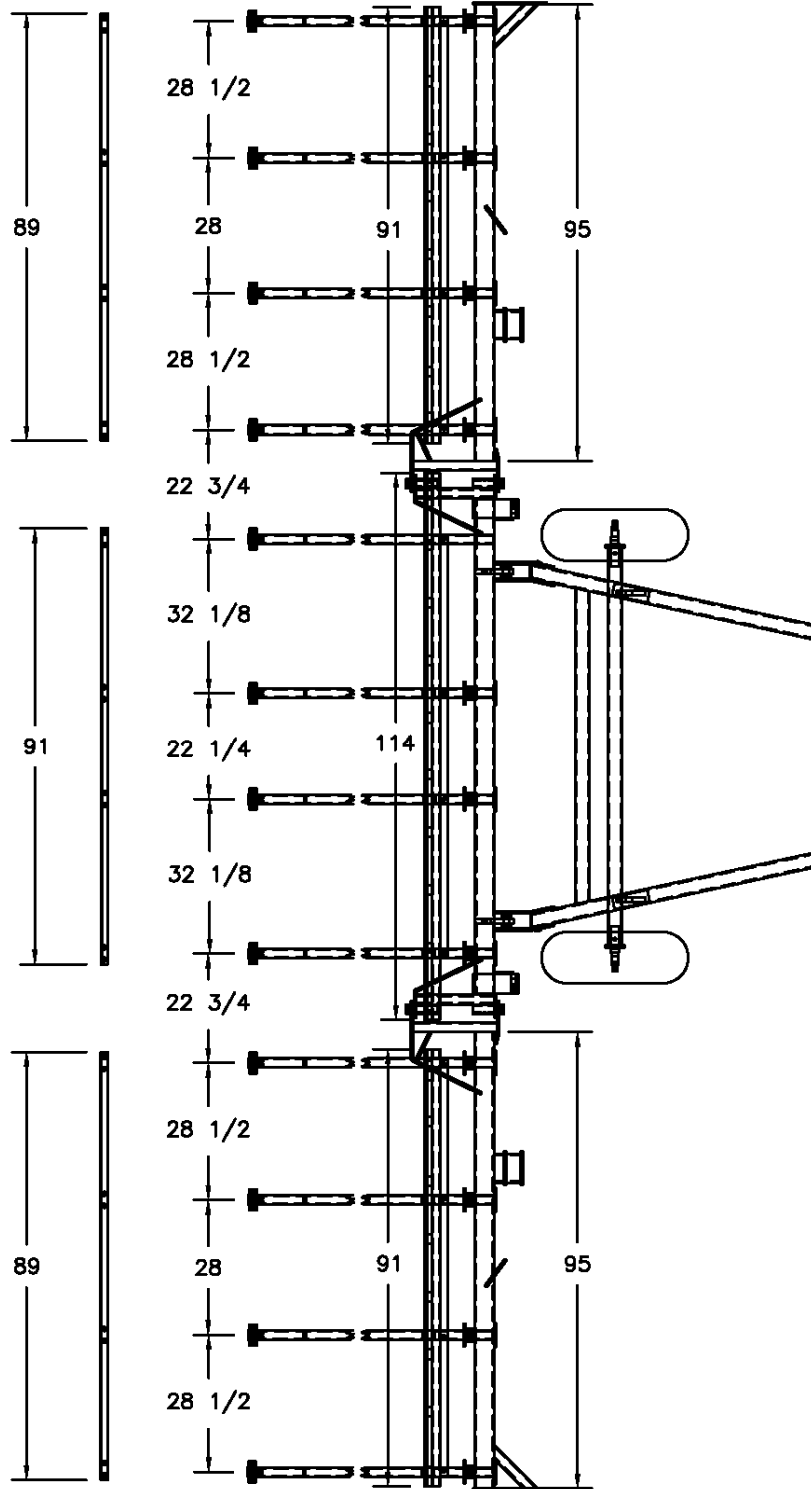

HD-130-U LAYOUT DIAGRAM

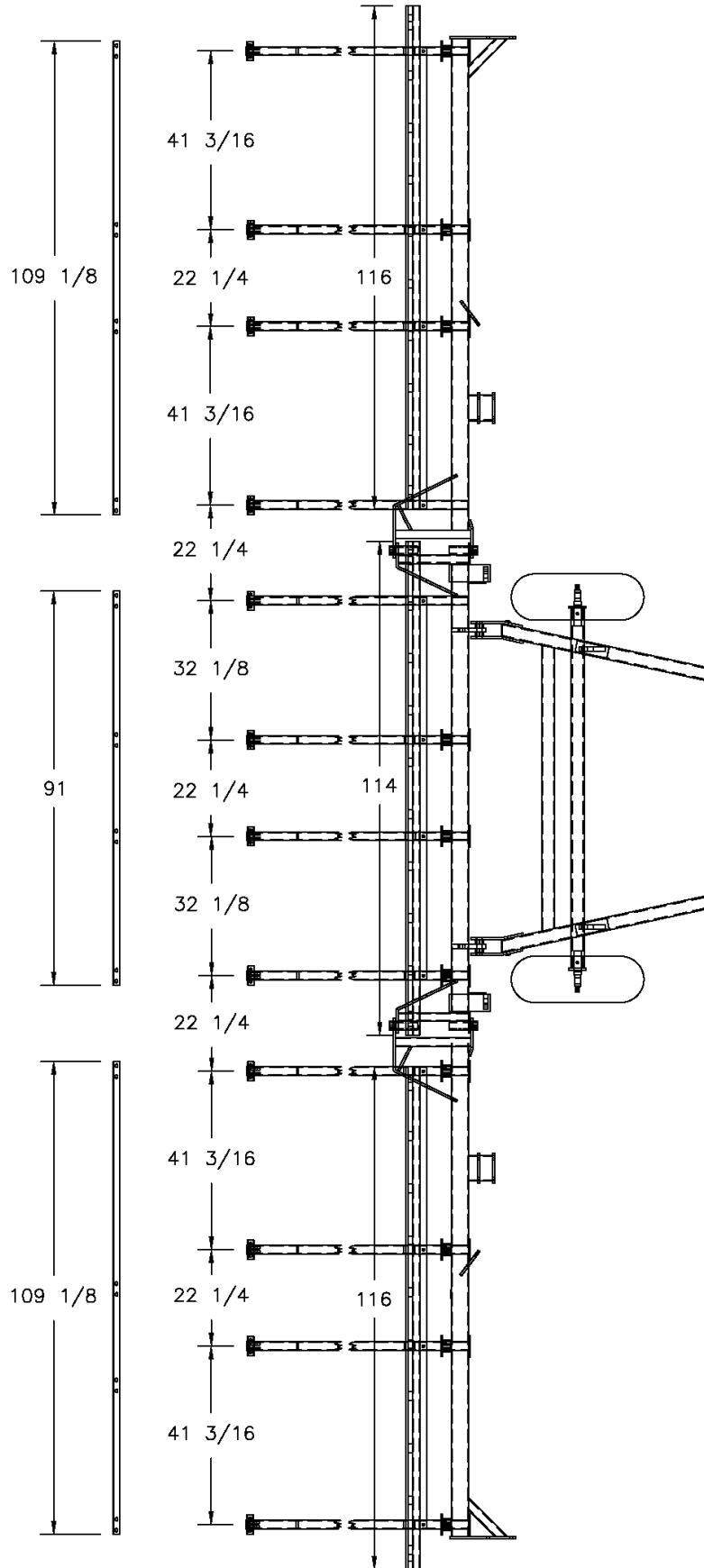

HD-132-T LAYOUT DIAGRAM

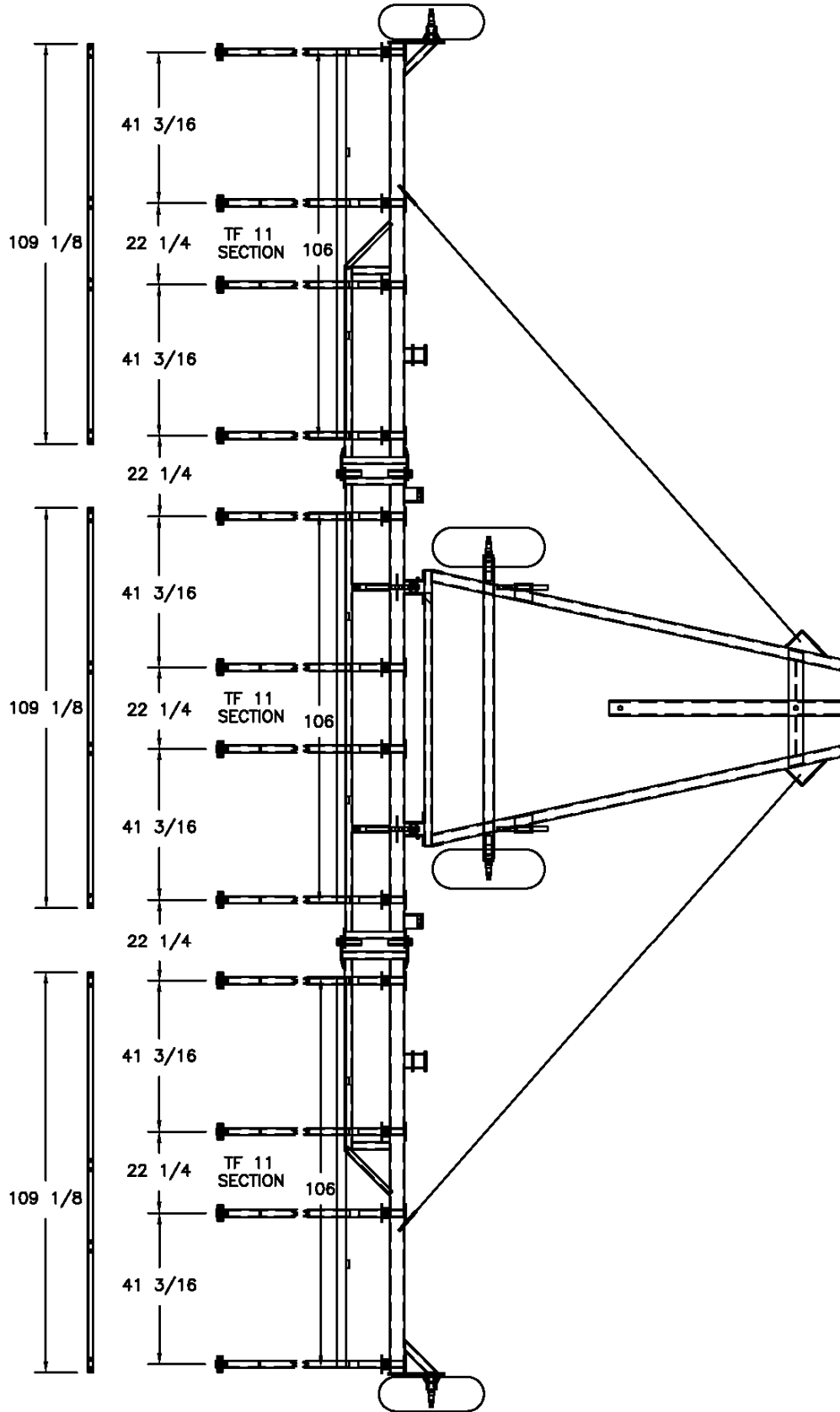

HD-132-U LAYOUT DIAGRAM

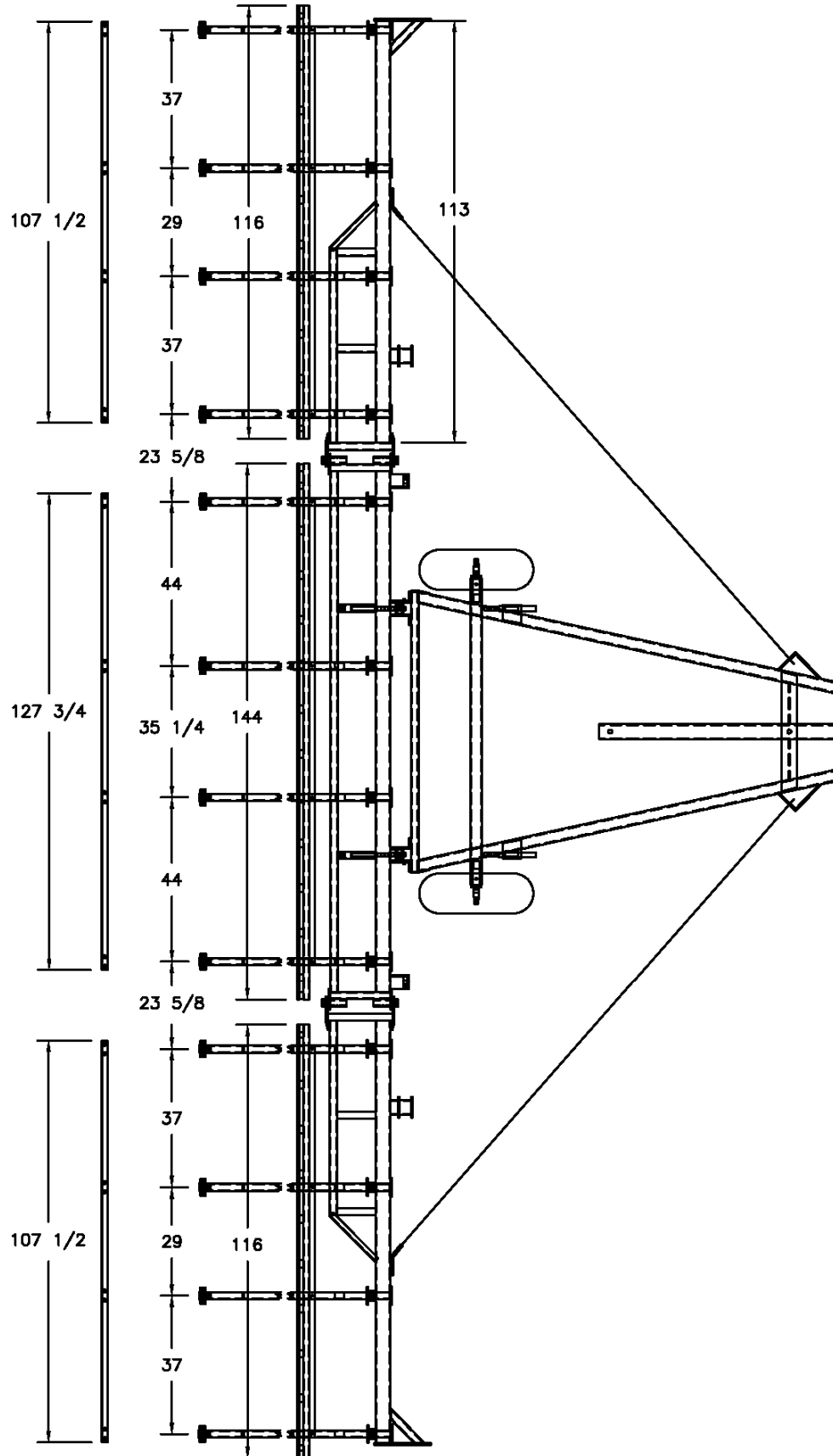

HD-136-U LAYOUT DIAGRAM

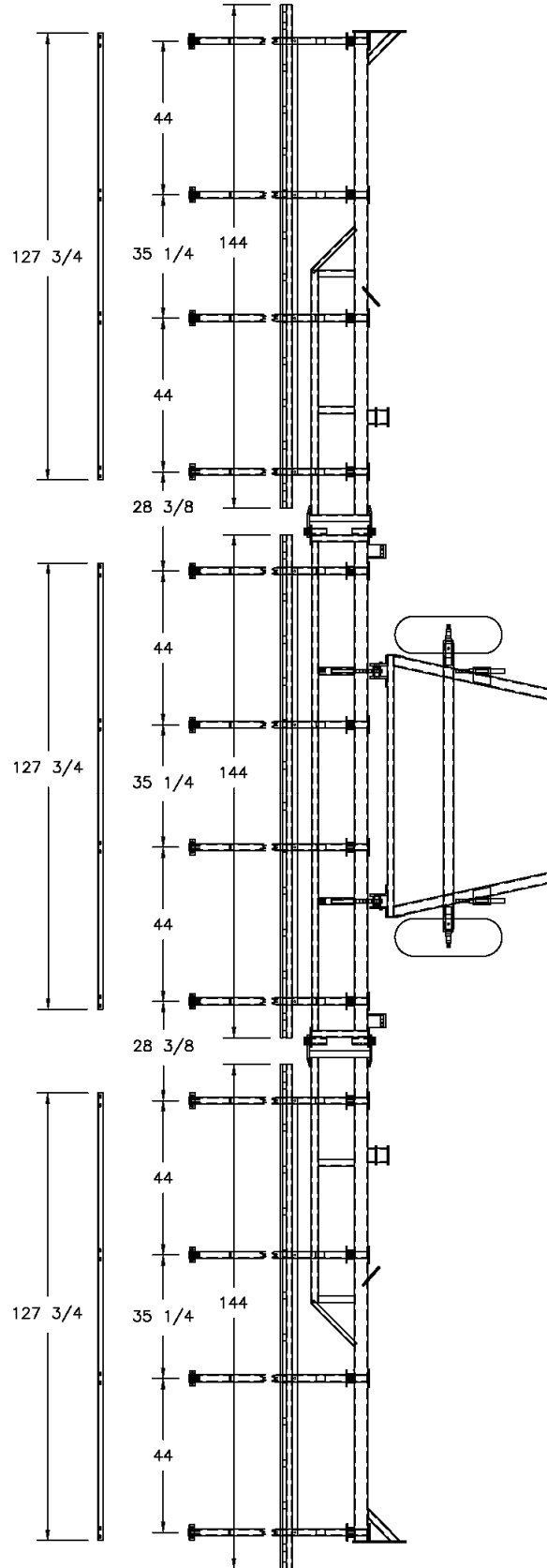

HD-140-U LAYOUT DIAGRAM

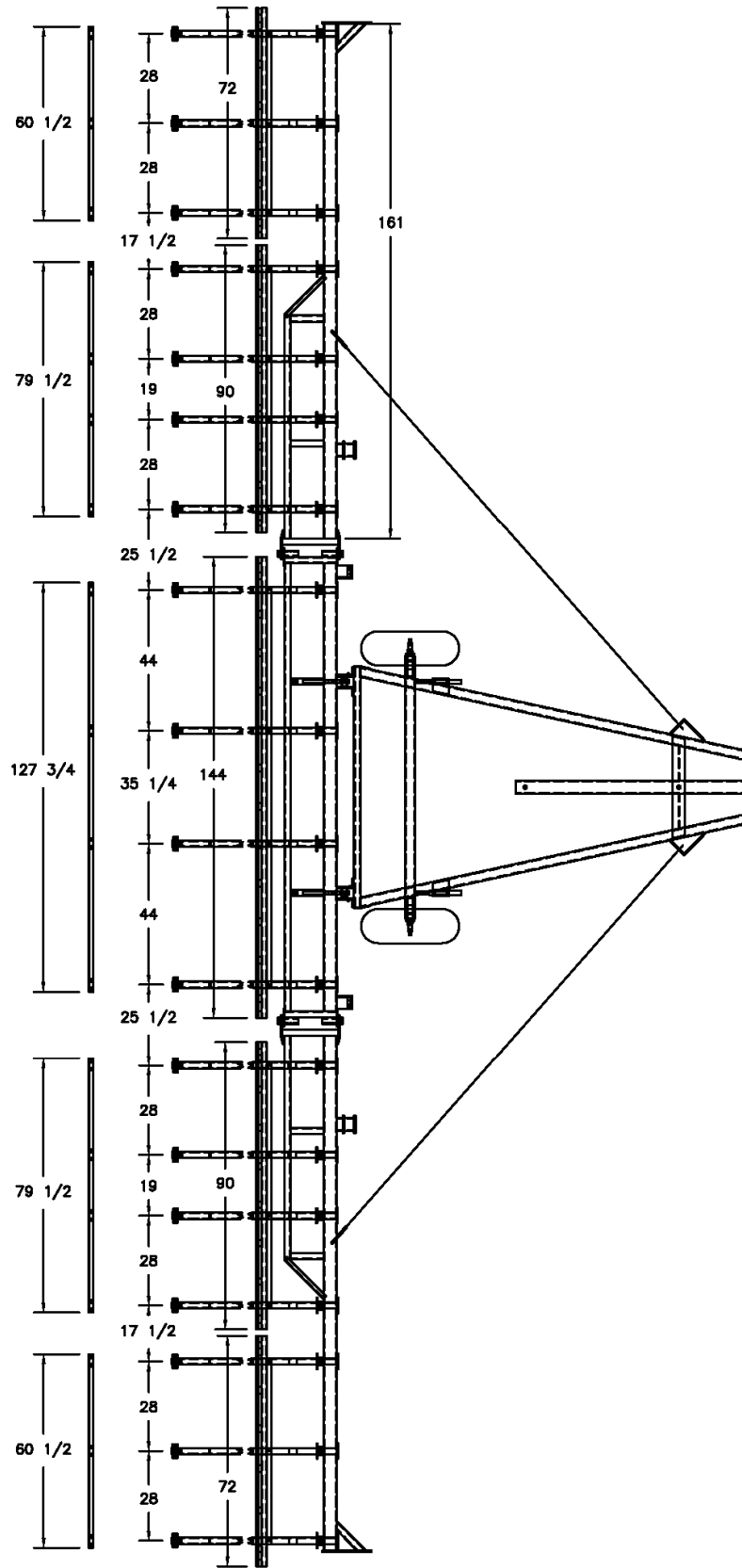

HD-140-T LAYOUT DIAGRAM

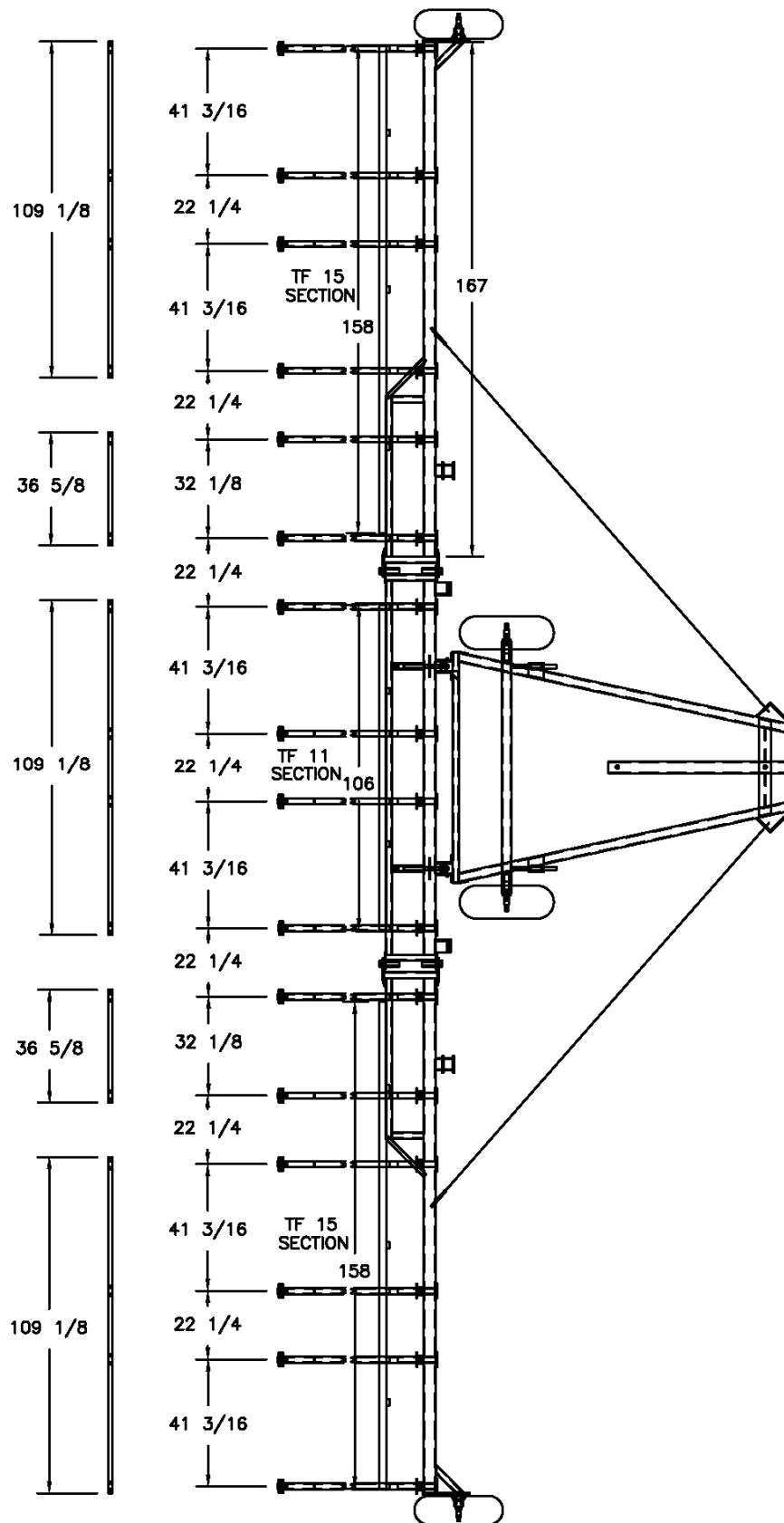

WARRANTY REGISTRATION FORM

This form must be filled out by the dealer and owner and sent to: McFarlane Mfg. Co., Inc., 1330 Dallas Street, P.O. Box 100, Sauk City, WI 53583.

WARRANTY REGISTRATION FORM & INSPECTION REPORT

WARRANTY REGISTRATION

This form must be filled out by the dealer and signed by both the dealer and customer at the time of delivery.

Customer Name _____ Dealer Name _____

Address _____ Address _____

City, state, code _____ City, state, code _____

Phone number (____) _____

Model _____ Serial Number _____ Delivery Date _____

DEALER INSPECTION REPORT

_____ Wheel bolts tight
_____ Fasteners tight
_____ Hydraulic hoses free
_____ Hydraulic fittings tight
_____ Arms free
_____ Check tire pressures
_____ Lubricate machine

SAFETY

_____ All decals installed
_____ Review operating and safety instructions

I have thoroughly instructed the buyer on the above described equipment; review included the operator's manual content, equipment care, adjustments, safe operation and applicable warranty policy.

Date _____ Dealer's signature _____

The above equipment and operator's manual have been received by me and I have been thoroughly instructed as to care, adjustments, safe operation, and applicable warranty policy.

Date _____ Owner's signature _____

Dealer Contact Information

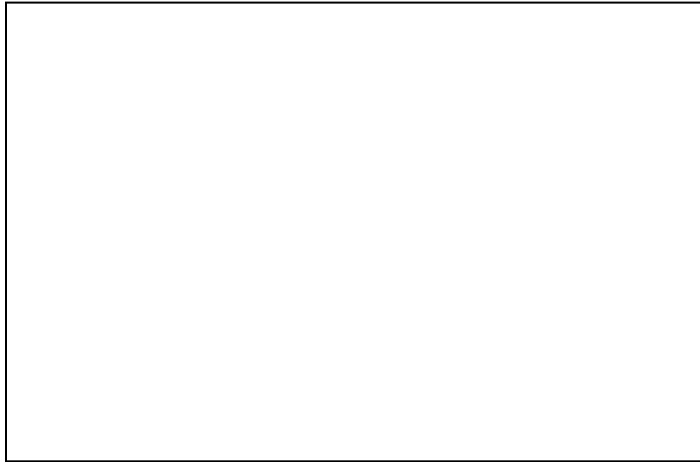

McFARLANE MANUFACTURING CO. INC.
1330 DALLAS STREET, P.O. BOX 100
SAUK CITY, WISCONSIN 53583
PHONE: (608) 643-3322
TOLL FREE: (888) 627-8569
FAX: (608) 643-3976
WEB: www.flexharrow.com