

AGRICULTURAL MACHINERY

sitrex®
Spa

**ASSEMBLING
USE AND MAINTENANCE
SPARE PARTS LIST**

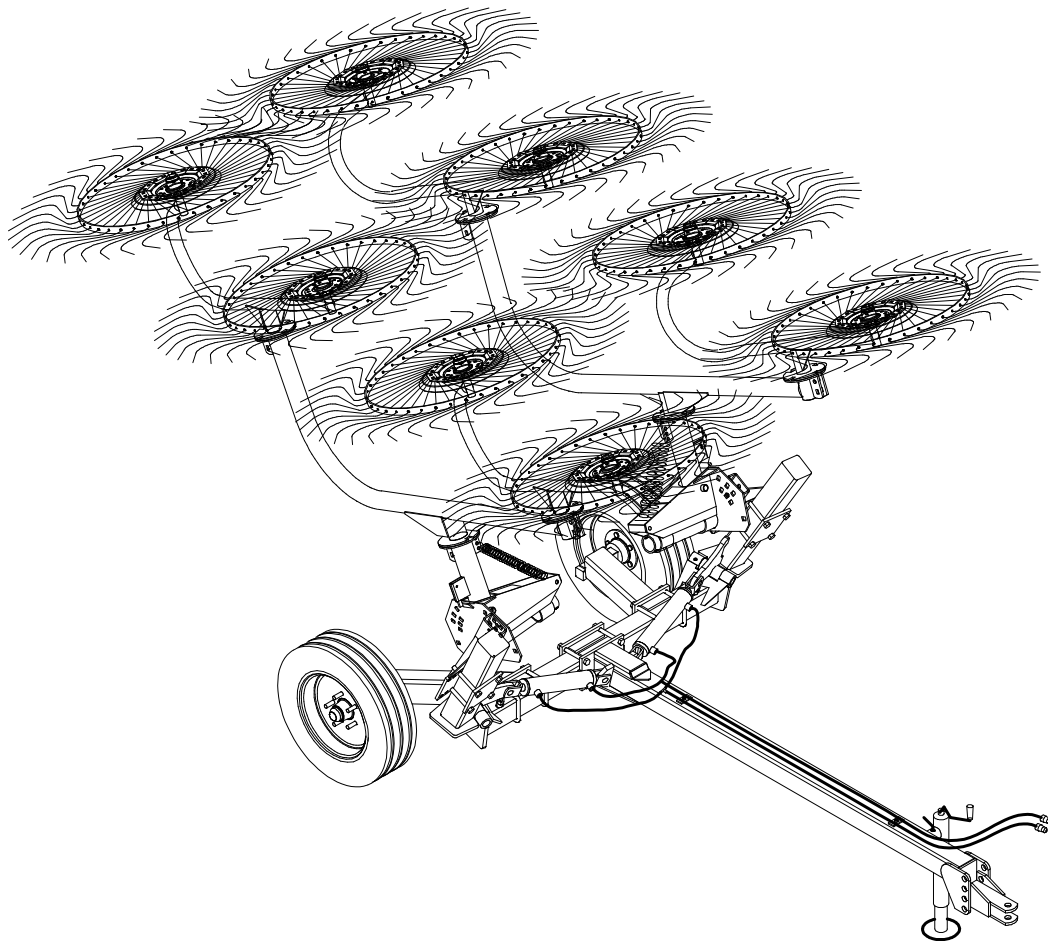

H/90-V **8**
10
12

Warranty

The manufacturer warrants new machinery to be free from defects in material and workmanship at the time of delivery to the original purchaser if correctly set up and operated according to this Operator's Handbook.

The manufacturer undertakes to repair or replace free of charge any defective part which should be returned by the purchaser (freight prepaid) and found to be defective on inspection authorised by the manufacturer during the warranty period.

This warranty shall be valid for 12 (twelve) months from the delivery of the goods to the original purchaser.

If the customer is unable to return the defective part to the manufacturer, the manufacturer cannot be held responsible for any cost due for repair or replacement of any part of the machine. He shall only supply the part(s) required for such repair and/or replacement.

The warranty shall be considered null and void when it is evident that the machine has been improperly used or at least repaired without authorisation.

The manufacturer shall not be held responsible for any obligation or agreement reached by any employers, agents or dealers who do not comply with the above warranty. The manufacturer cannot be held responsible for the subsequent damages. This warranty replaces any other warranty, either explicit or implied, as well as any other obligation of the manufacturer.

NOTE:

ALL WARRANTY WORK OR REPAIRS MUST BE APPROVED BY THE MANUFACTURER BEFORE WORK BEGIN.

ANY WORK OR REPAIRS MADE BEFORE APPROVAL MAY NOT BE COVERED UNDER WARRANTY.

PLEASE NOTIFY YOUR SALES & SERVICE DEPARTMENT OF THIS POLICY.

ASSEMBLY

1) Attach the tractor hitch (35) to the drawbar (1) using the two pins (37), fastening with the screws (40) and washers (26).

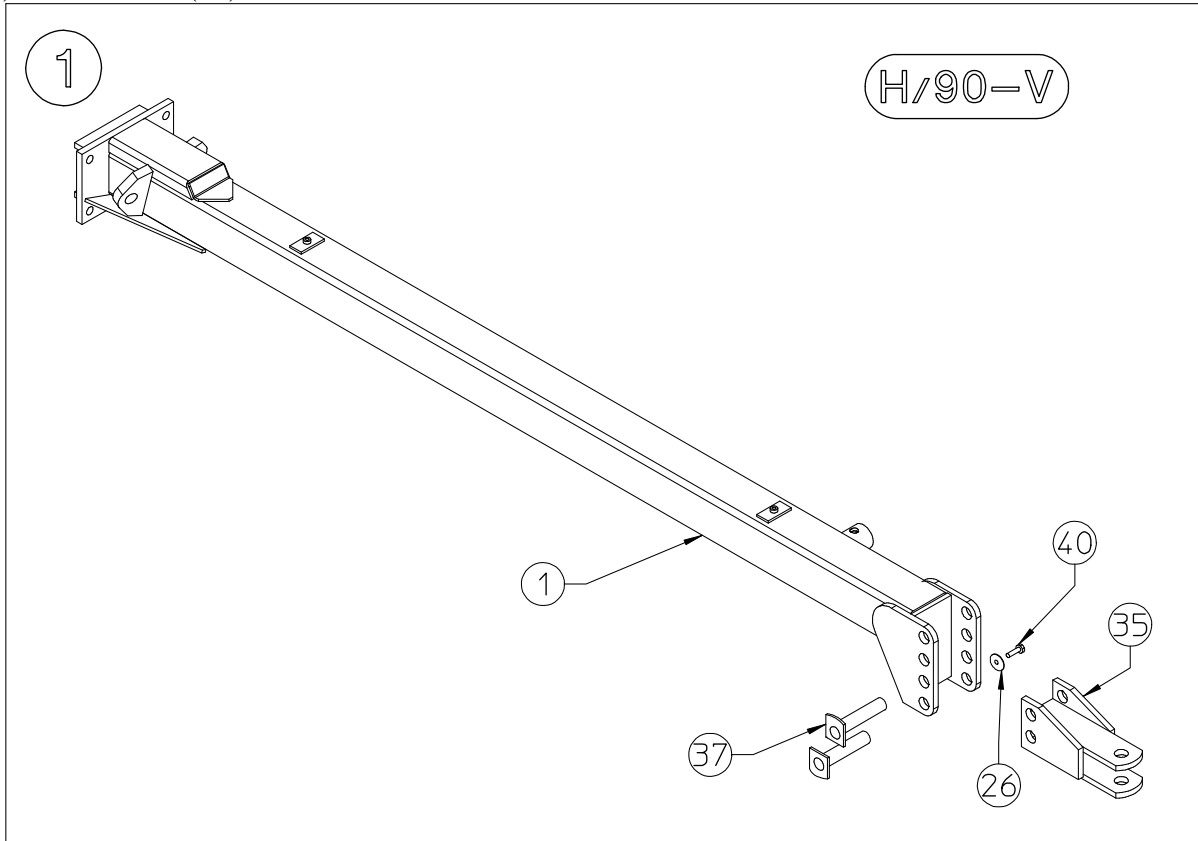

2) Attach the drawbar (1) to the frame (2) centering it between plates (A) and fastening it with the plate (7), screws (27) and nuts (29).

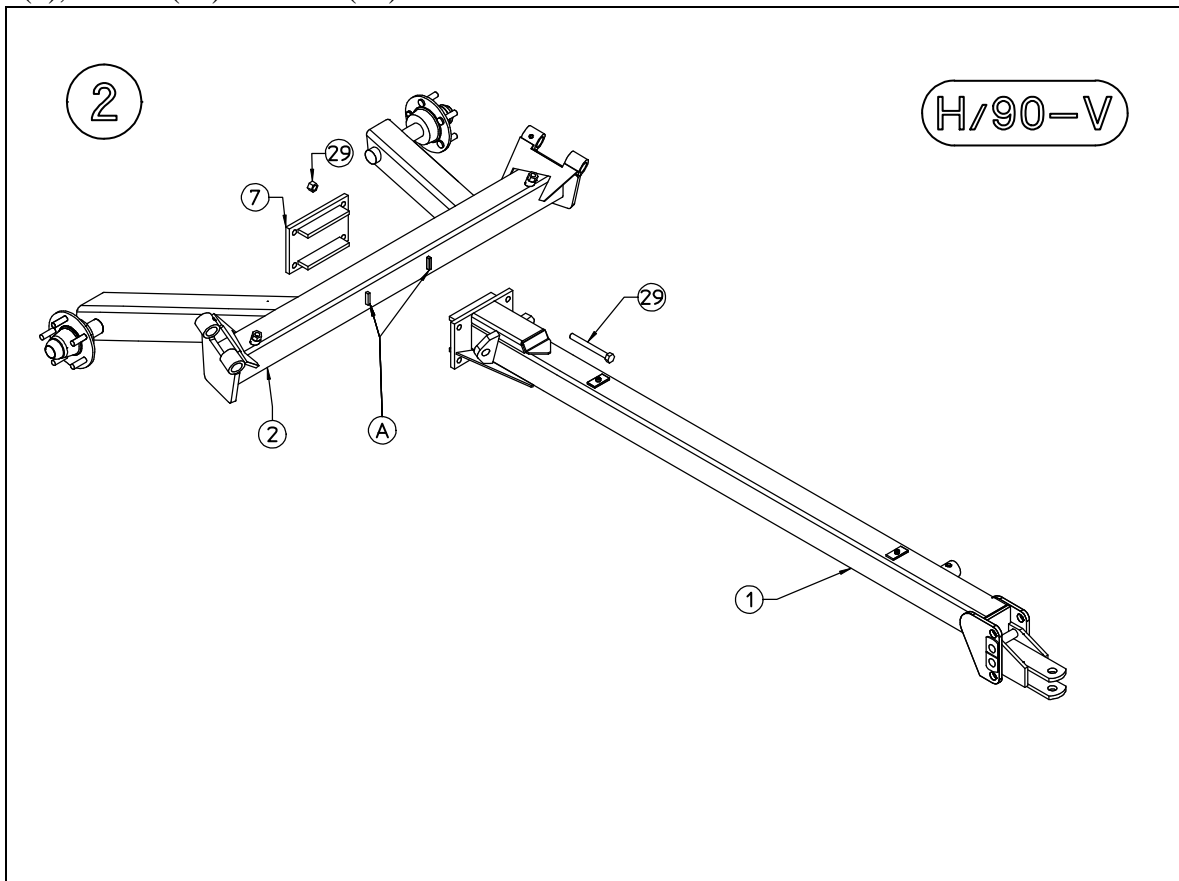

3) Mount wheels (53) to hubs (B) on frame (2) using nuts (47).

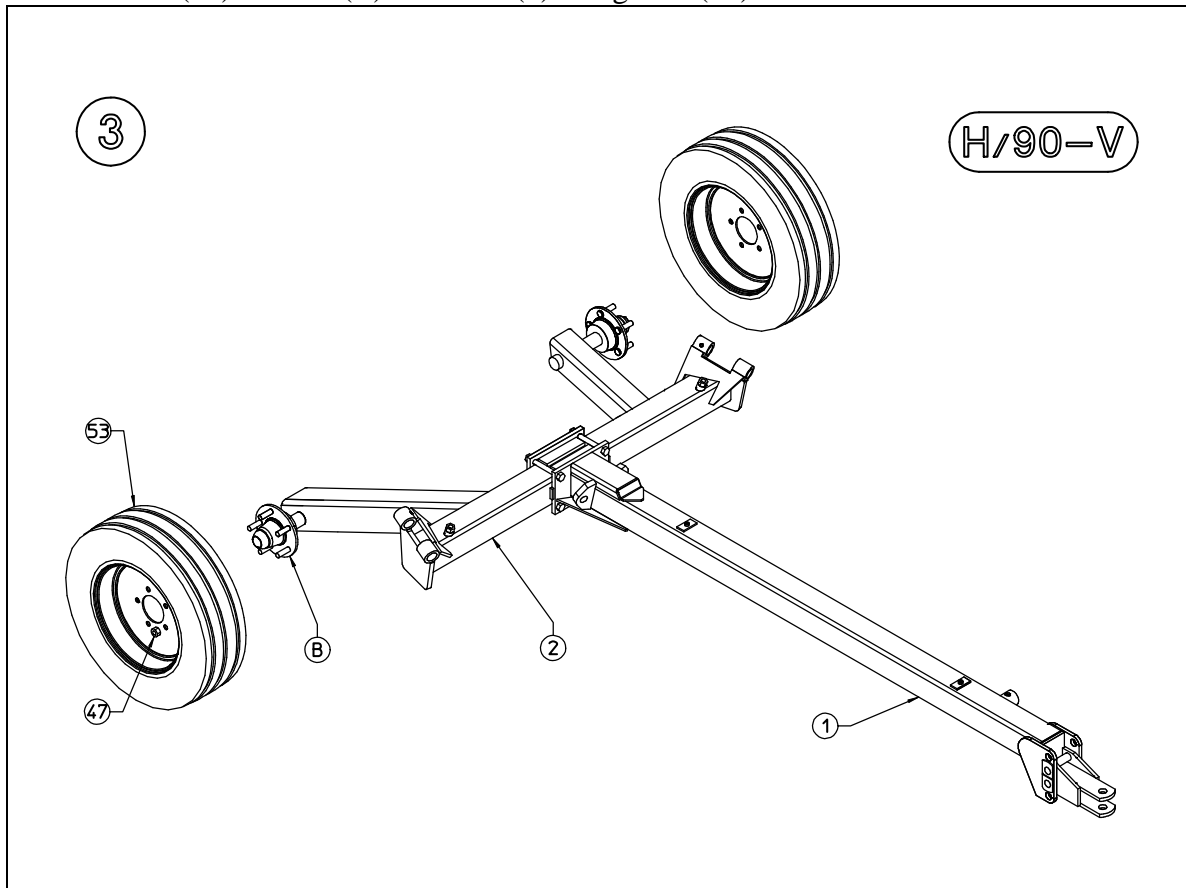

4) Attach mount (D) of the drawbar parking stand (11) to pin (C) on drawbar (1) and fasten with pins (14) - (39)

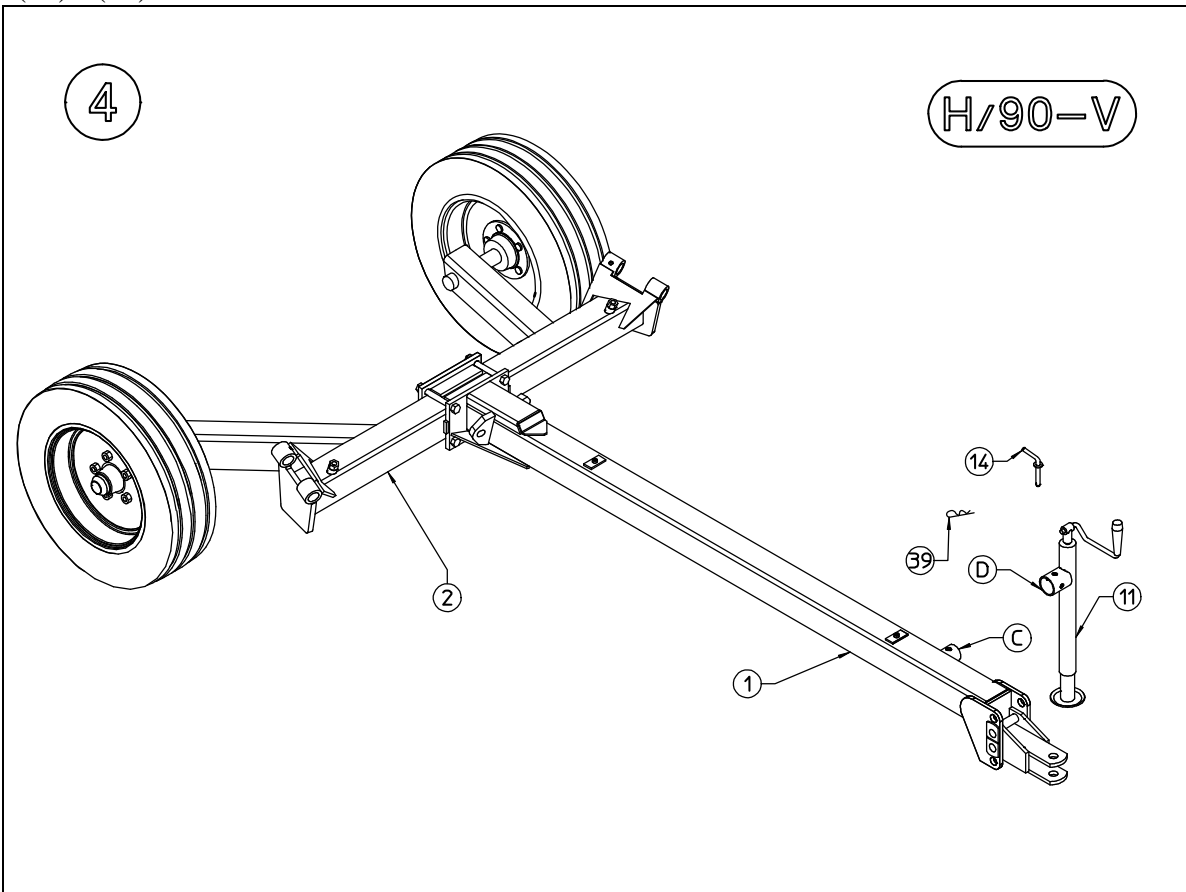

5) Insert pins (12) into holes (E) on the cart and holes (F) on the arms (3) - (4), so that arms (3) - (4) are hinged to the cart. Fasten pins (12) with pins (33).

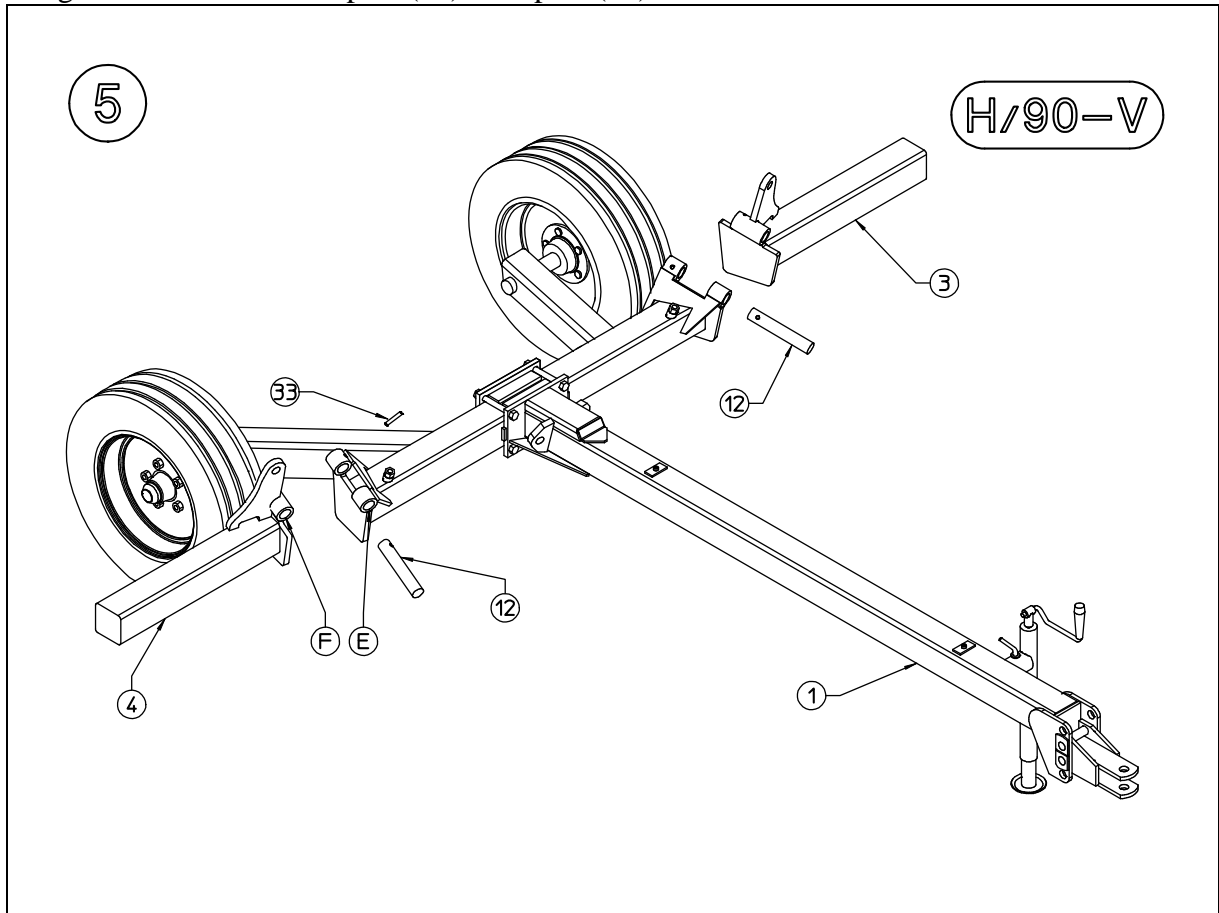

6) Attach the cylinders (25) to the lugs (G) and (H) using pins (13) and pins (32)

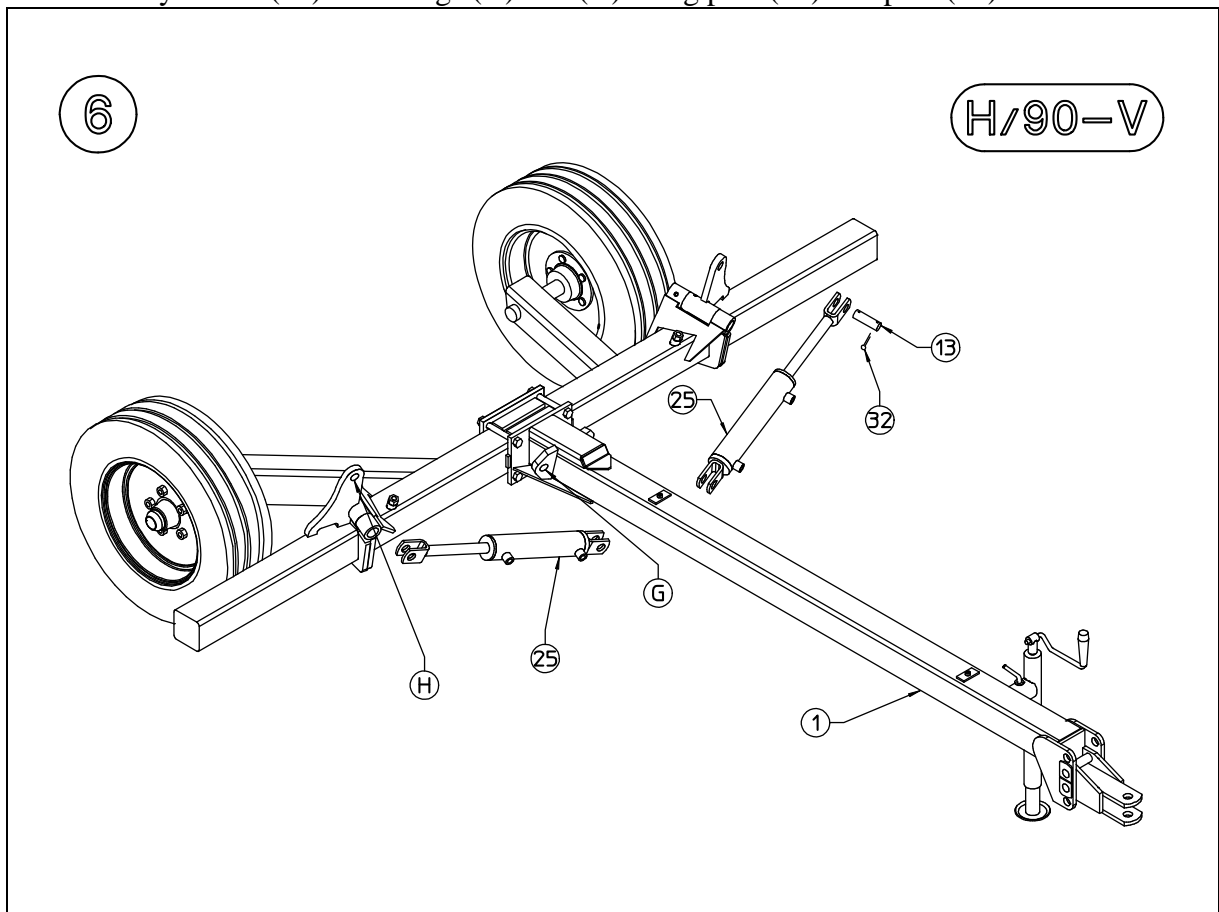

HYDRAULIC SYSTEM ASSEMBLY

- a) Attach washers (18) and the reducer nipples (19) at holes V on cylinders (25). If the reducer nipple (19) is an “A” type, attached the side with the reduced hole towards hole V on cylinders (25). If nipple (19) is a “B” type, either side can be connected (See detail).
- b) Attach the curved end of pipes (16) to the reducer nipples (19) and join them at them at center with pipe union (22).
- c) Attach washer (18) and the normal hole nipple (20) at holes X on cylinder (25).
- d) Attach washer (18) the rotating union (21) and union (22) to hole (Z) on the other cylinder (25).
- e) Connect the curved end of pipe (17) to nipple (20) and the straight end to union (22)
- f) Connect the rotating female ends of pipes (15) to union (22)
- g) Place washers (23) and connect the quick-release coupling (24) to the straight male ends of pipes (15)
- h) Check to make sure that all connections are correctly fastened.
- i) Attach the hose collar (54) to the lugs on drawbar, fastening on correctly position (see step 9)

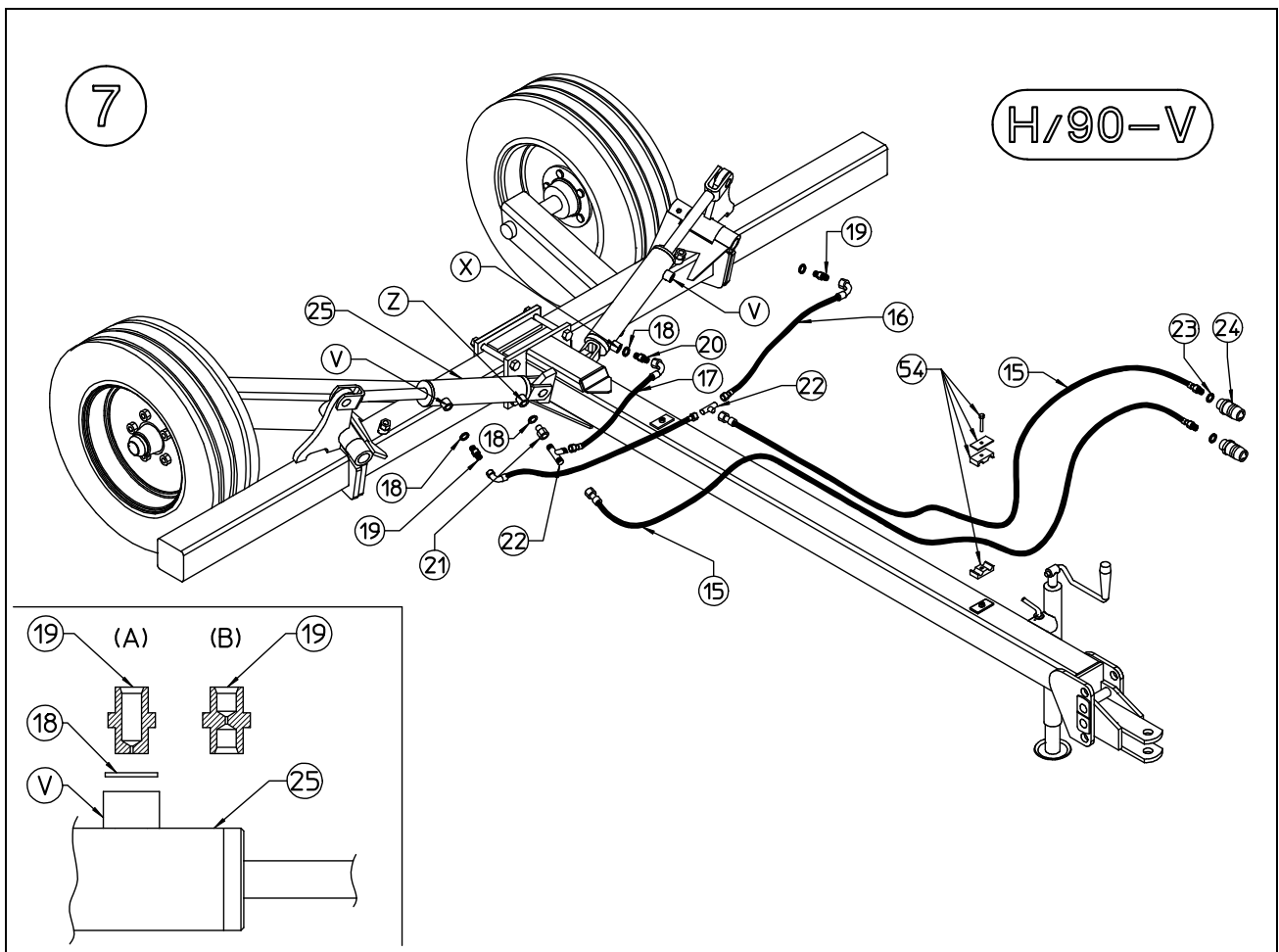

8/1) Fasten supports (8) and (10) to the frame using plates (34), screws (27) and nuts (29). Supports (8) and (10) can also be attached by passing the screws through slot (M). This position is useful in particular for model V/8.

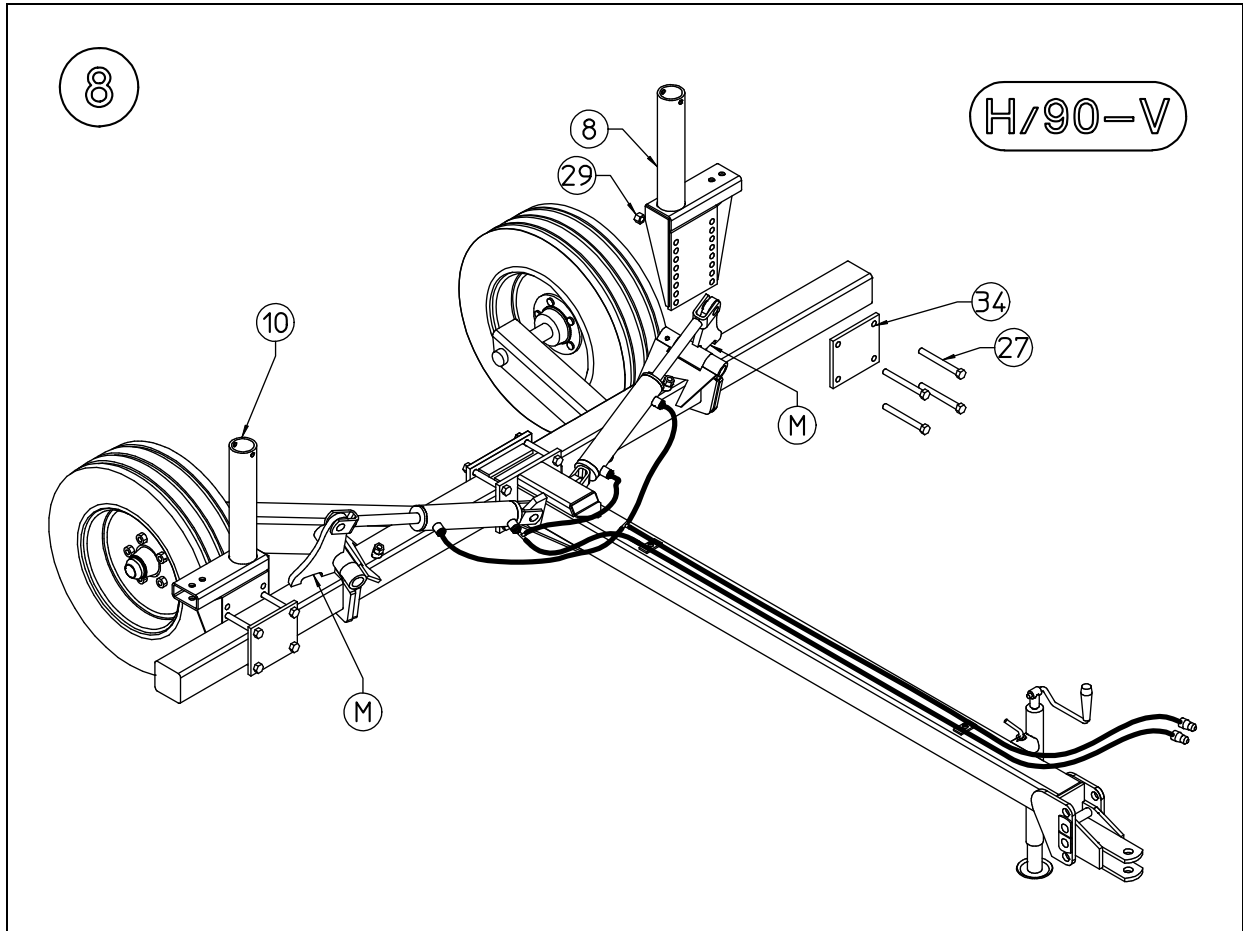

9) The H/90 cart is now completely assembled and we can begin the assembly of the hay rakes.

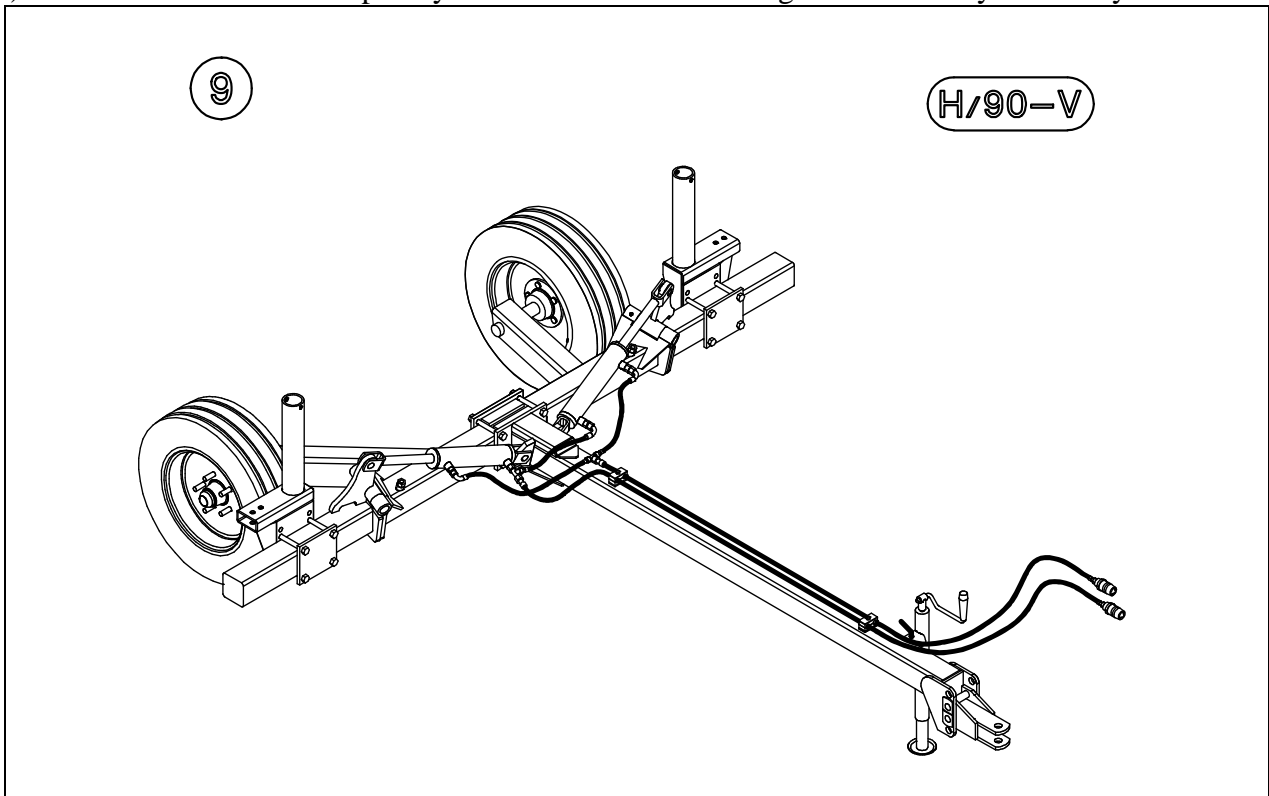

10) Place the pivoting bracket 2-2a (LH-RH, looking at the machine from the rear) over support (8), fastening it with the bushing (9) and the spring pin (29).

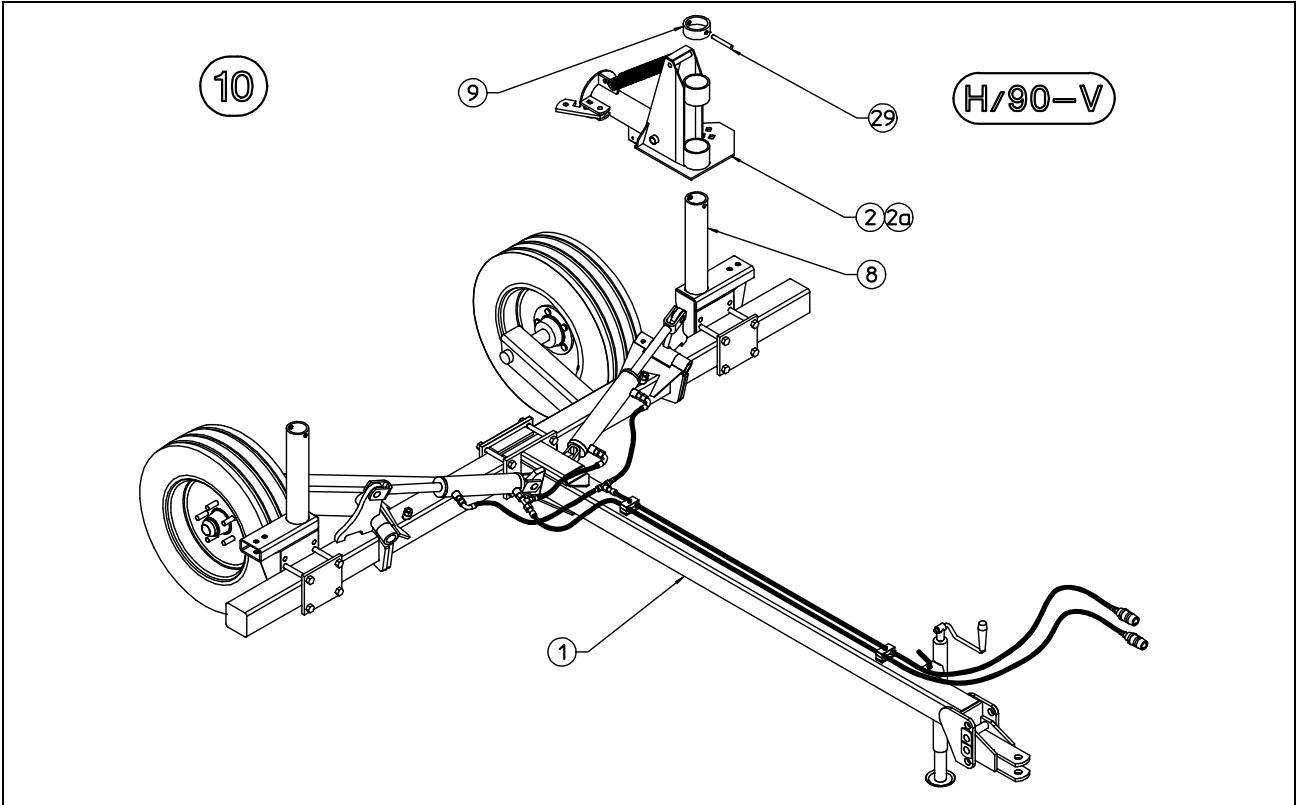

11) Attach arm (3) to the pivoting bracket (2) and fasten with lever (7) and pin (4). Shown in the illustration is the V/10 hay rake; the same procedure applies to the V/8 and V/12.

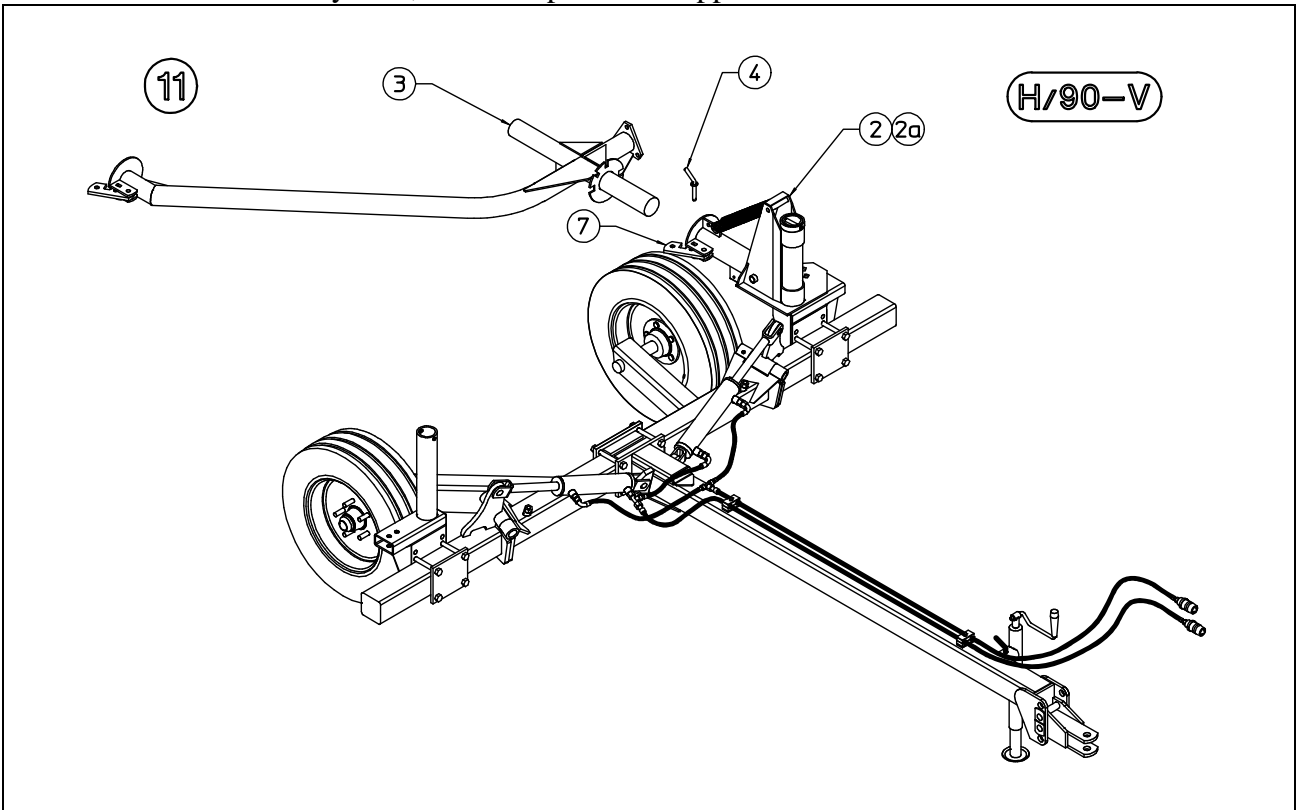

12) Attach arm (4) to arm (3) using screws (5) and nuts (6). (V/10 and V/12 only)

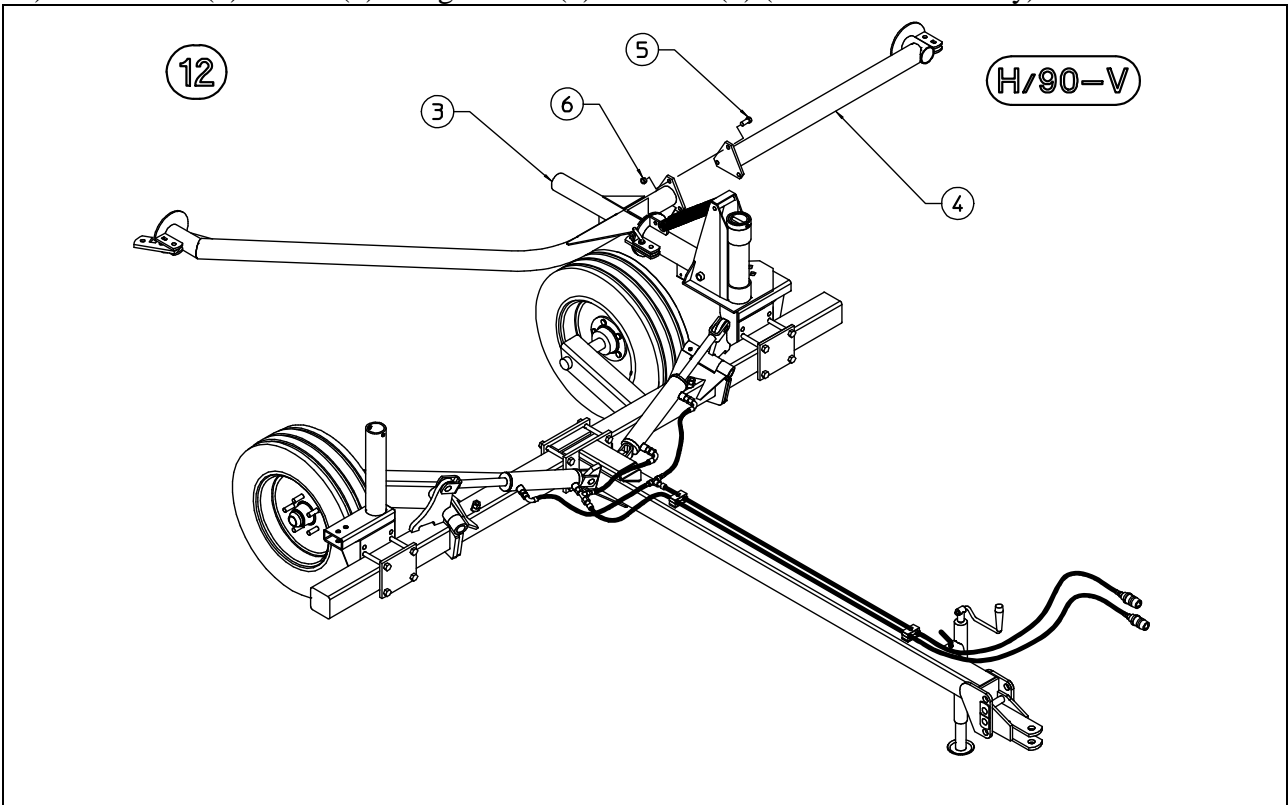

13) Attach brackets (5) to arms (3) and (4), fastening with levers (6) and pins (7). Attach bracket (8) with screws (9) and nuts (10).

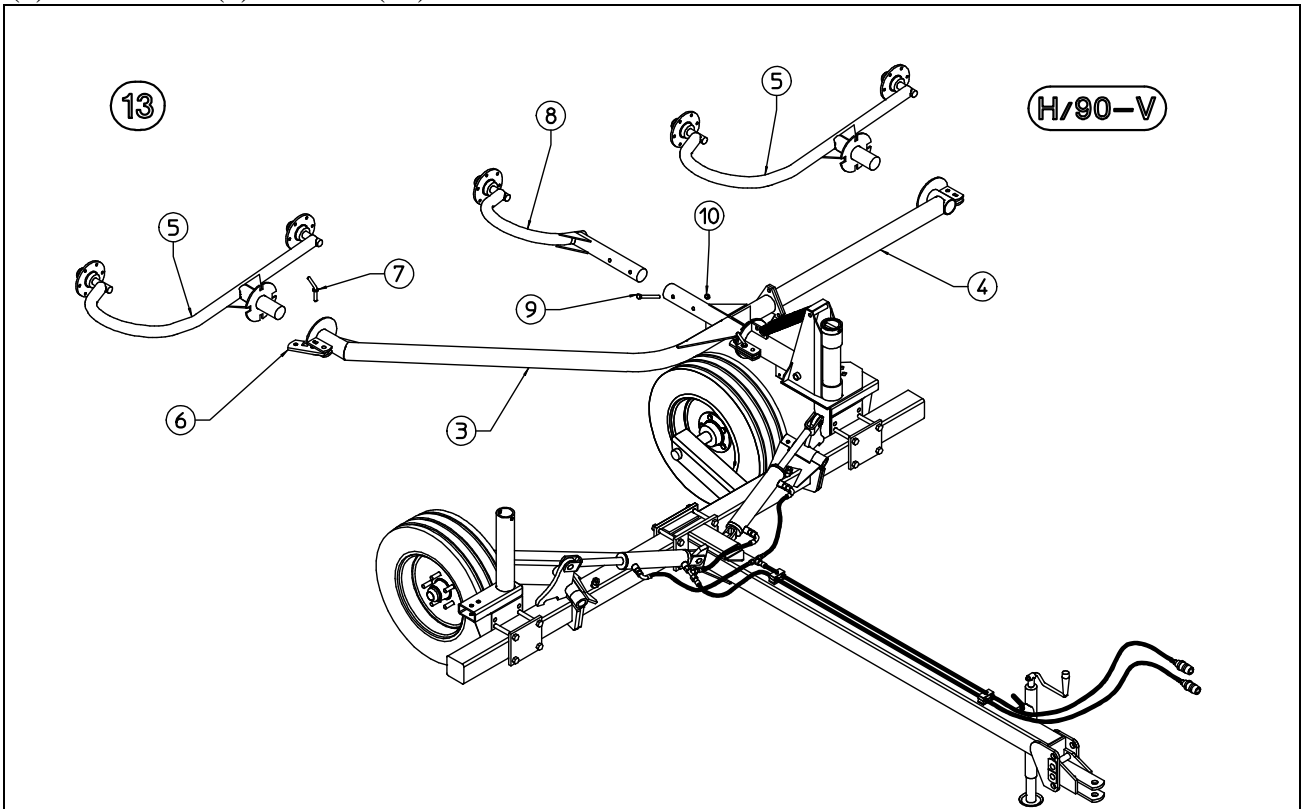

14) Position the hay rake arm so that pin (12) can be inserted in one of the holes on the quadrant (11), then attach the rake wheels (13) to the hubs (14) using screws (15), washers (17) and nuts (16).

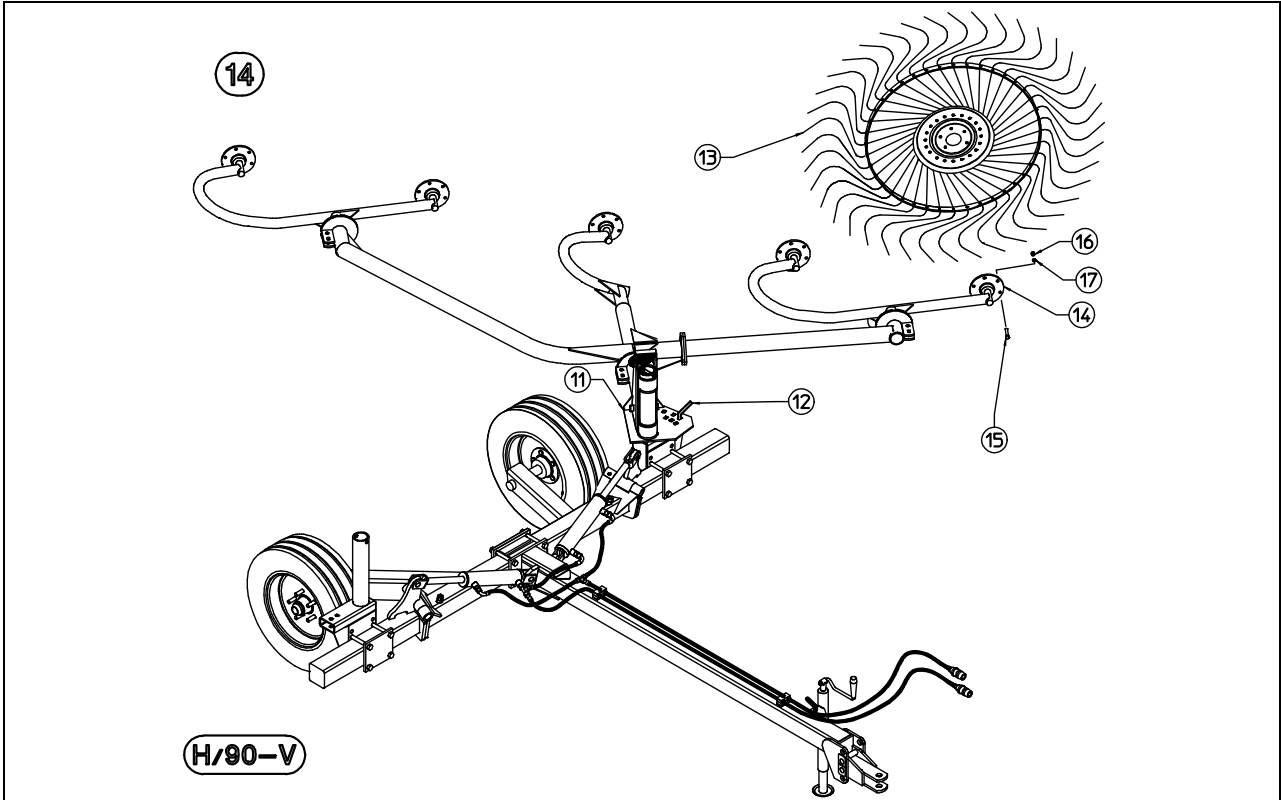

15) Repeat the procedures for steps 10 to 14 on the right side of the machine to complete the H/90-V cart. Shown in the illustration is the V/10 model

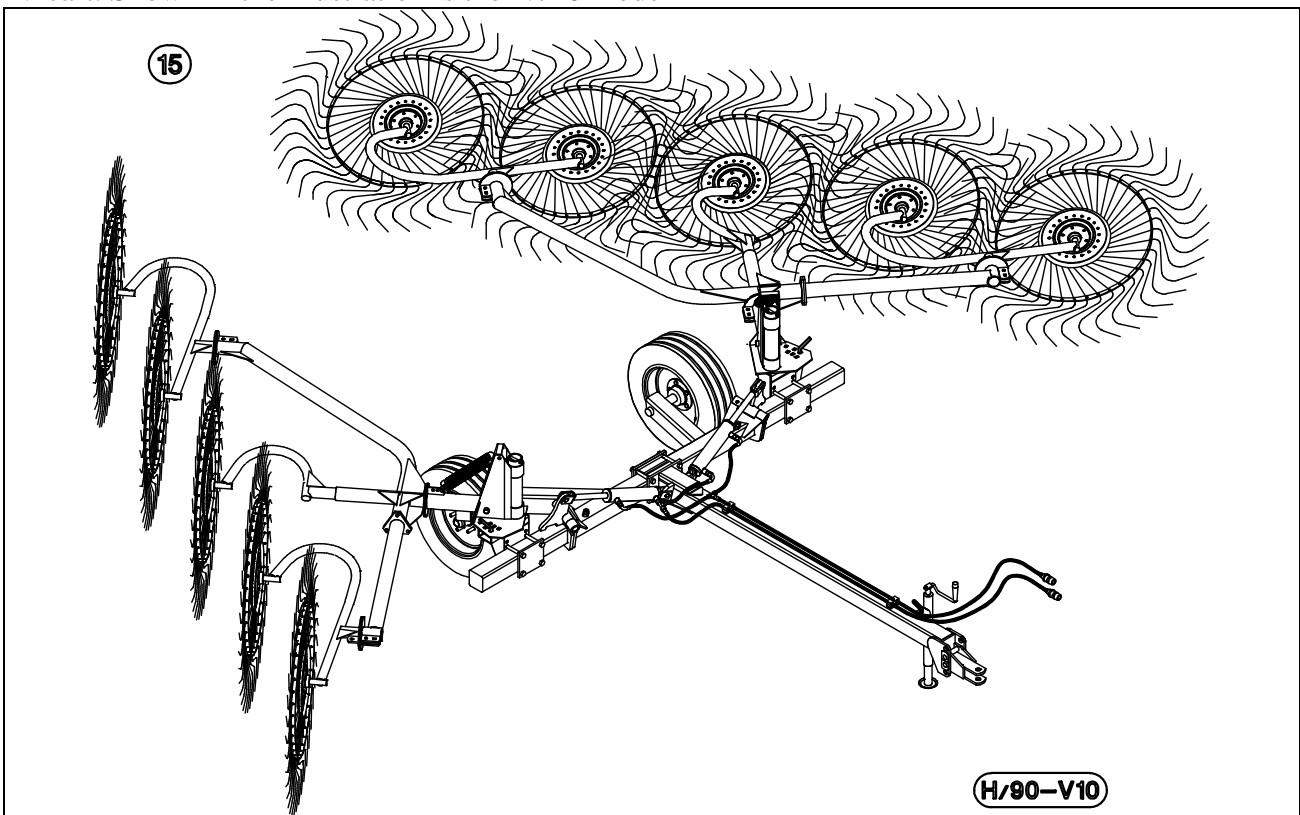

ADJUSTMENTS FOR MACHINE USE

The machine must be adjusted according to the specific work requirements. Thus the various adjustment possibilities will be described, so you can choose that which best suits your work requirements.

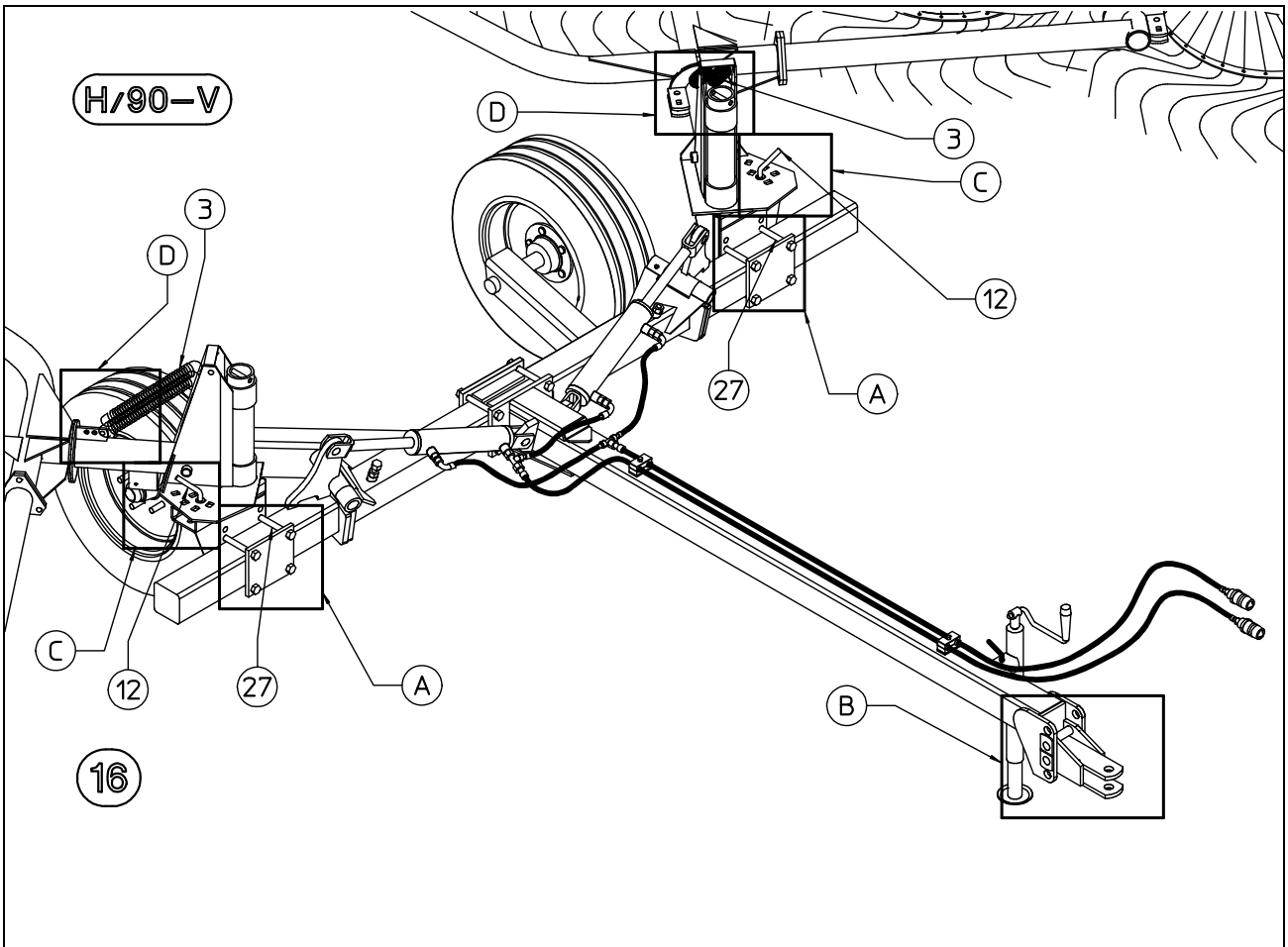

- A) The hay rake supports can be adjusted vertically and horizontally by inserting the screws (27) into the different holes on the support and by sliding the support lengthwise along the frame.
- B) The tractor hitch must be adapted to the tow hook on the tractor and adjusted according to the pressure of the rake wheels on the ground.
- C) The hay rake arms can be pivoted and locked into different positions using pin (12).
- D) The pressure of the rake wheels on the ground can be regulated also by means of the suspension springs (3), which can be set in different positions.

17) The support arms (8) and (10) can be adjusted in height by placing the screws (27) in the different holes (R) and in width by sliding the support along the frame before tightening the screws. The narrowest position is with the screws passing through the slot. The adjustments depend on the pressure of the rake wheels on the ground and the desired swath width. For the V/8 it is best to set all supports at the low position.

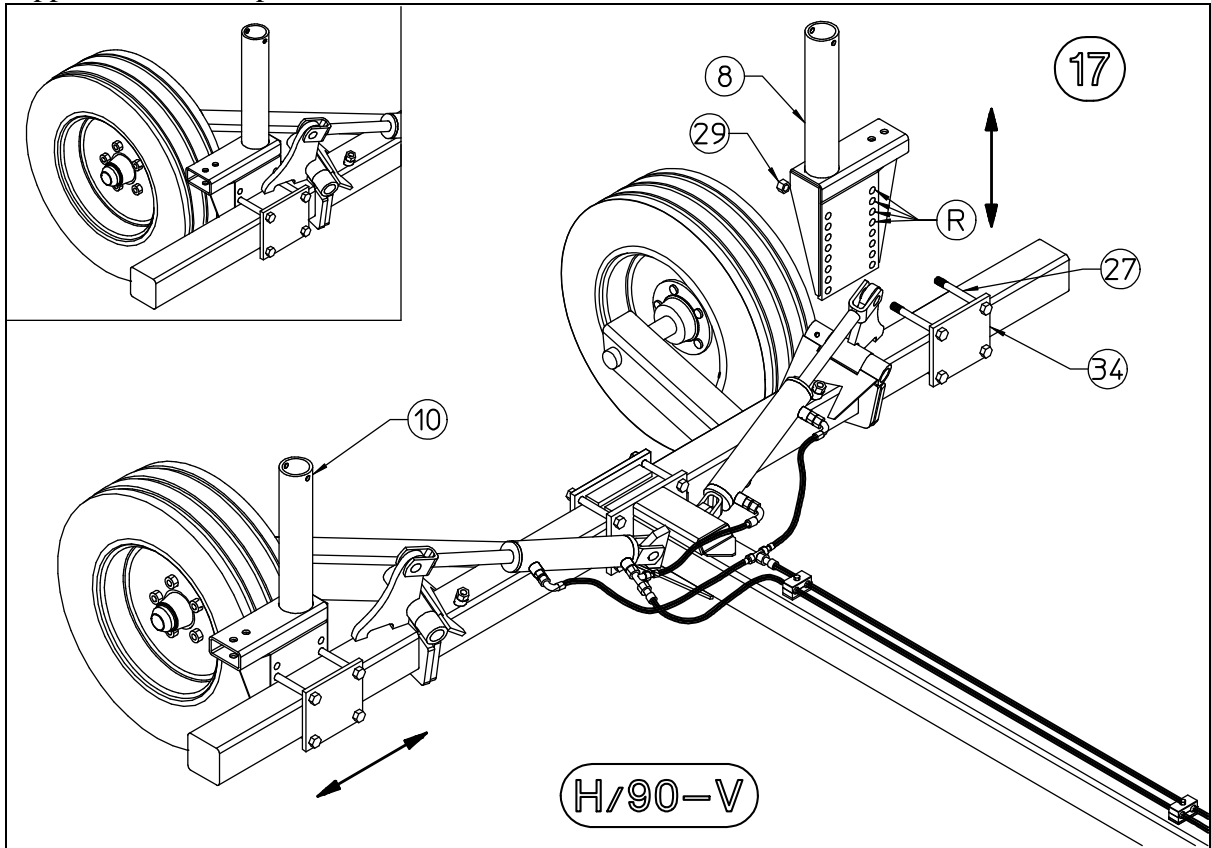

18) The tractor hitch (35) can be set in different positions, using holes (36), to allow coupling to all tractor types. By turning the hitch upside-down from (A) to (B), additional settings are available.

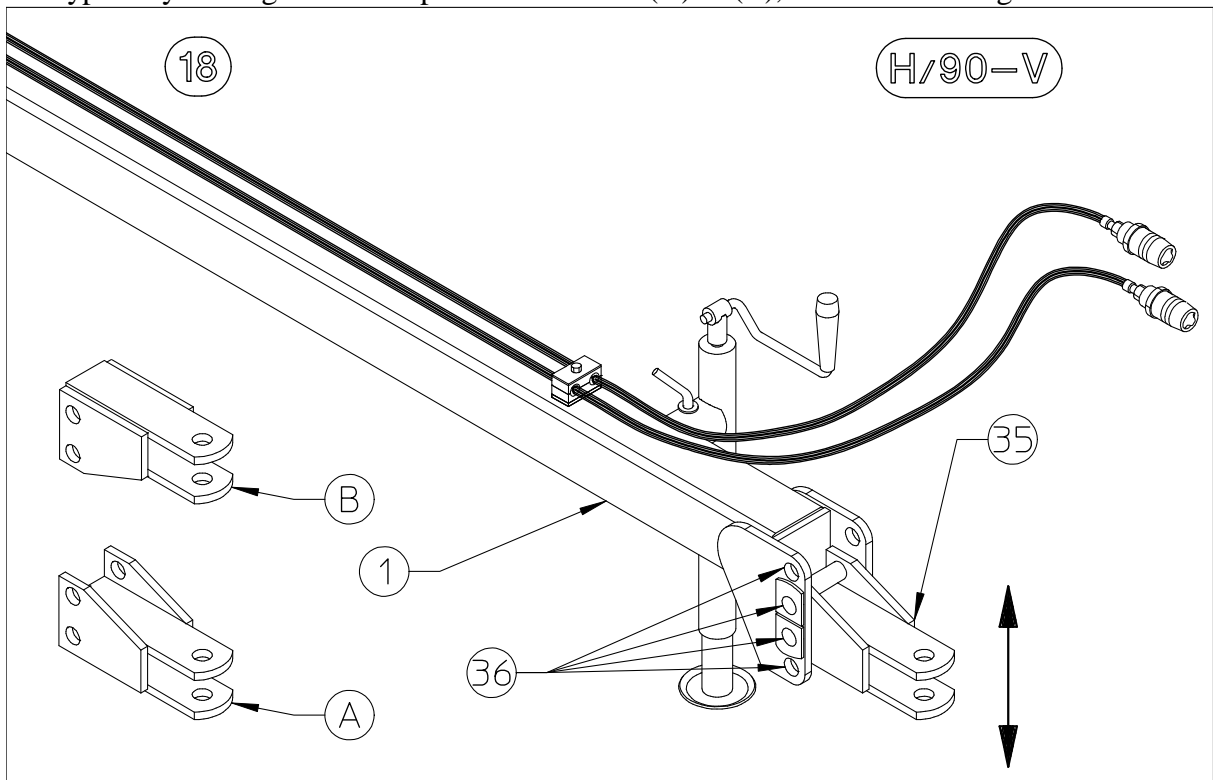

19) The hay rake arm can be pivoted to obtain a different working angle and further variation of the swath. Pin (12) is inserted in the different holes in quadrant (2) and fastened with the clip (3). The central position is the best for most working conditions.

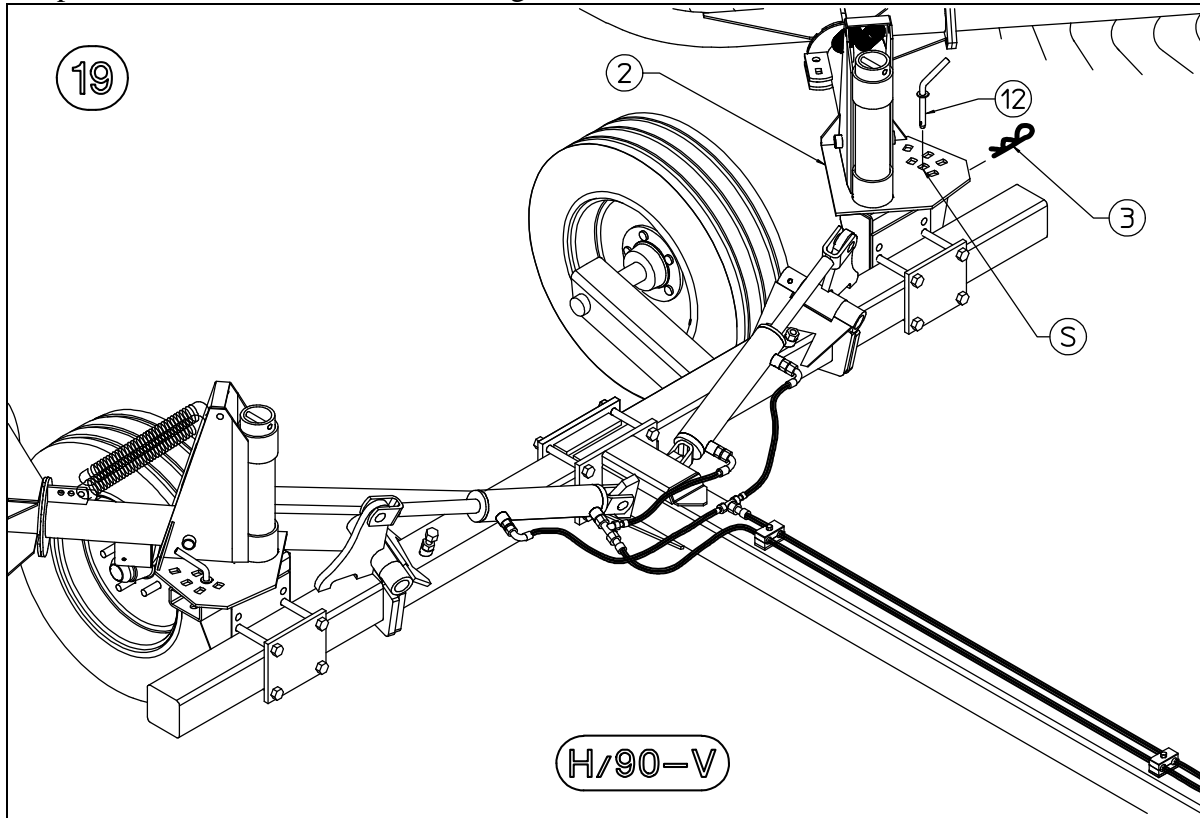

20) The springs (3) should normally be attached as shown in the large illustration and in the detail at the upper left (attached at the second hole). They can be attached to the other three holes to obtain a different rake wheel pressure on the ground.

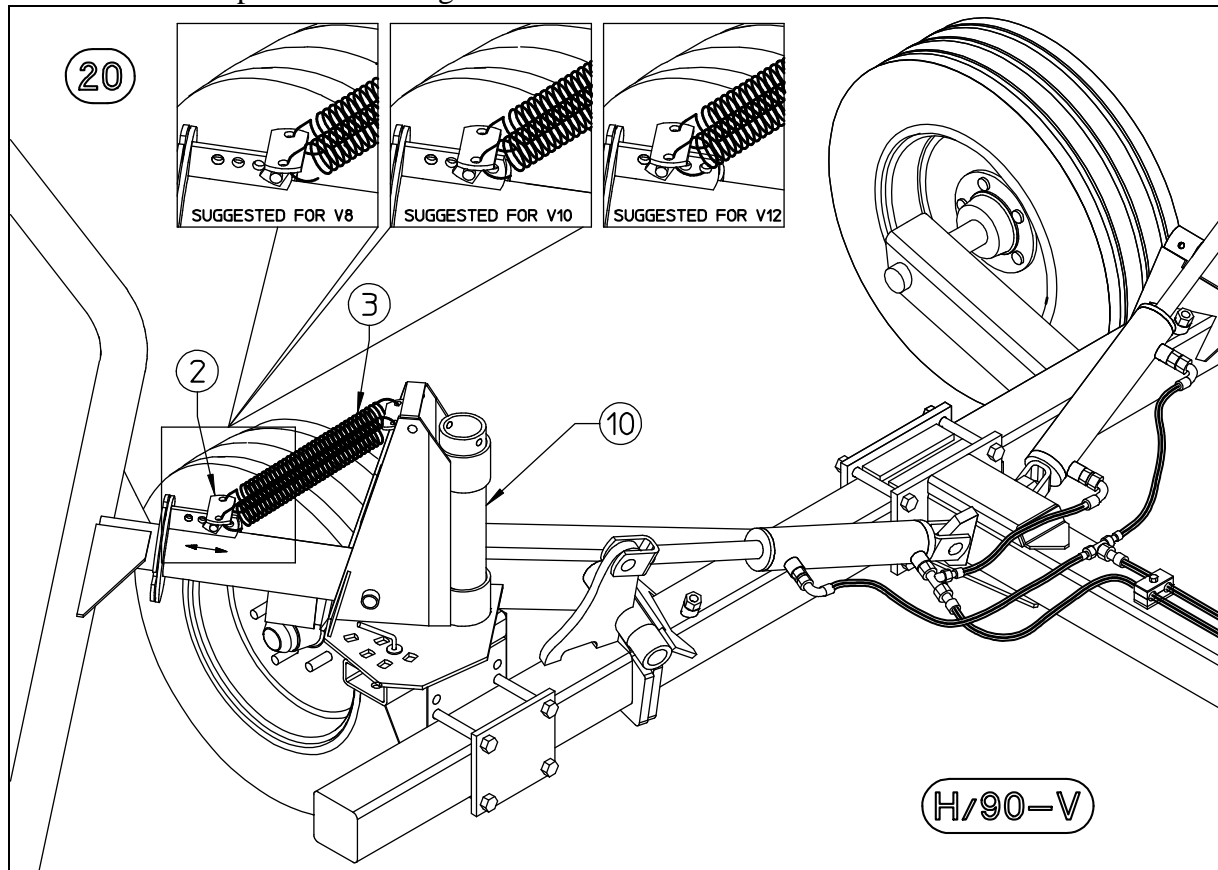

Here we indicate the approximate measurements for the assembly of the RP/8 - RP/10 - RP/12 and the corresponding swaths sizes.

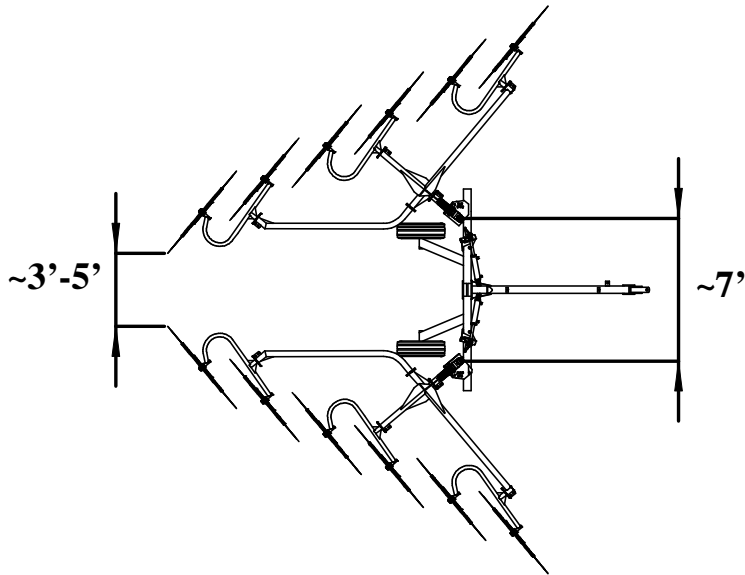

H90 - V12

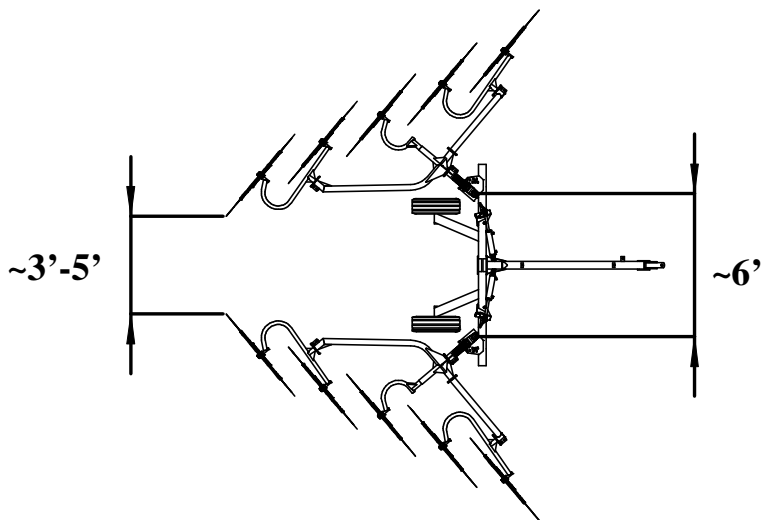

H90 - V10

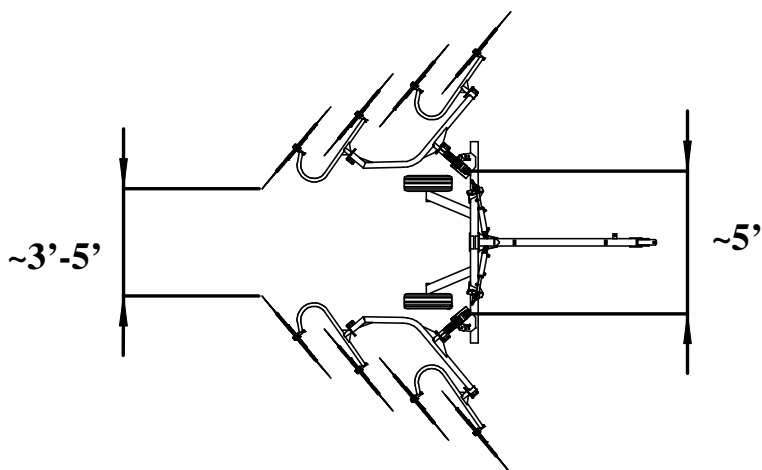

H90 - V8

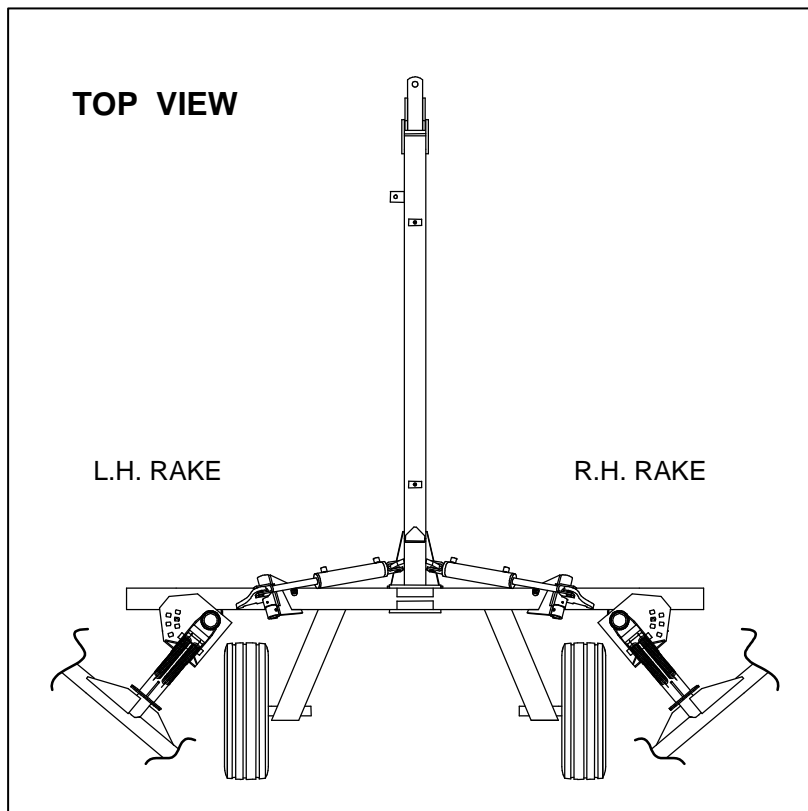
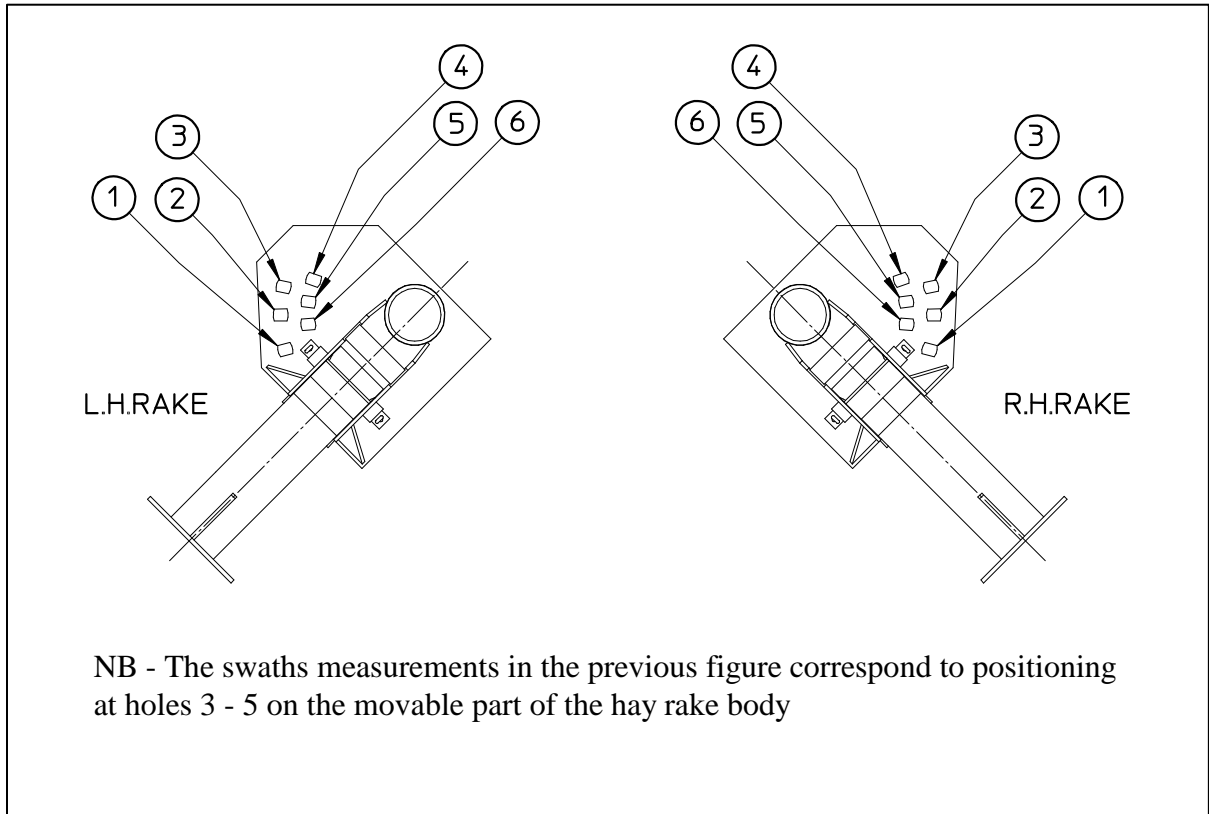

23) To transport the machine, the safety locks must be locked (see picture), raise the hay rakes, which can be done from the tractor using the distributor lever. It is not necessary to move the hay rakes from the working position in order to raise them.

For safety reasons, after raising the side arms attach the chain (55) to the two supports (8) and (10) by connecting the hooks (56) and (57) to the welded chain ring (T).

Warning: The chain **MUST** be removed before putting the arms back into the working position.

When moving a short distance in the field, it is not necessary to lock the hay rakes with the chain (55); however, when leaving the field, the safety locks **must be used**.

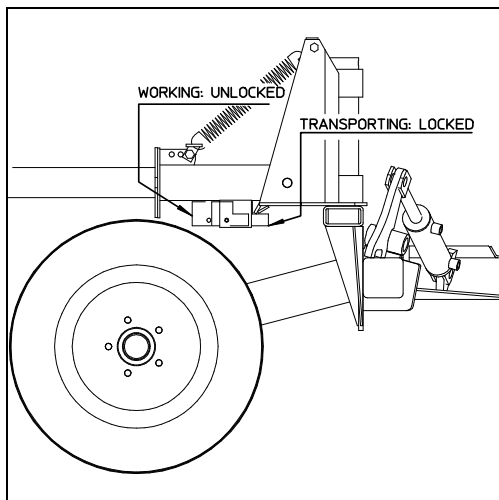
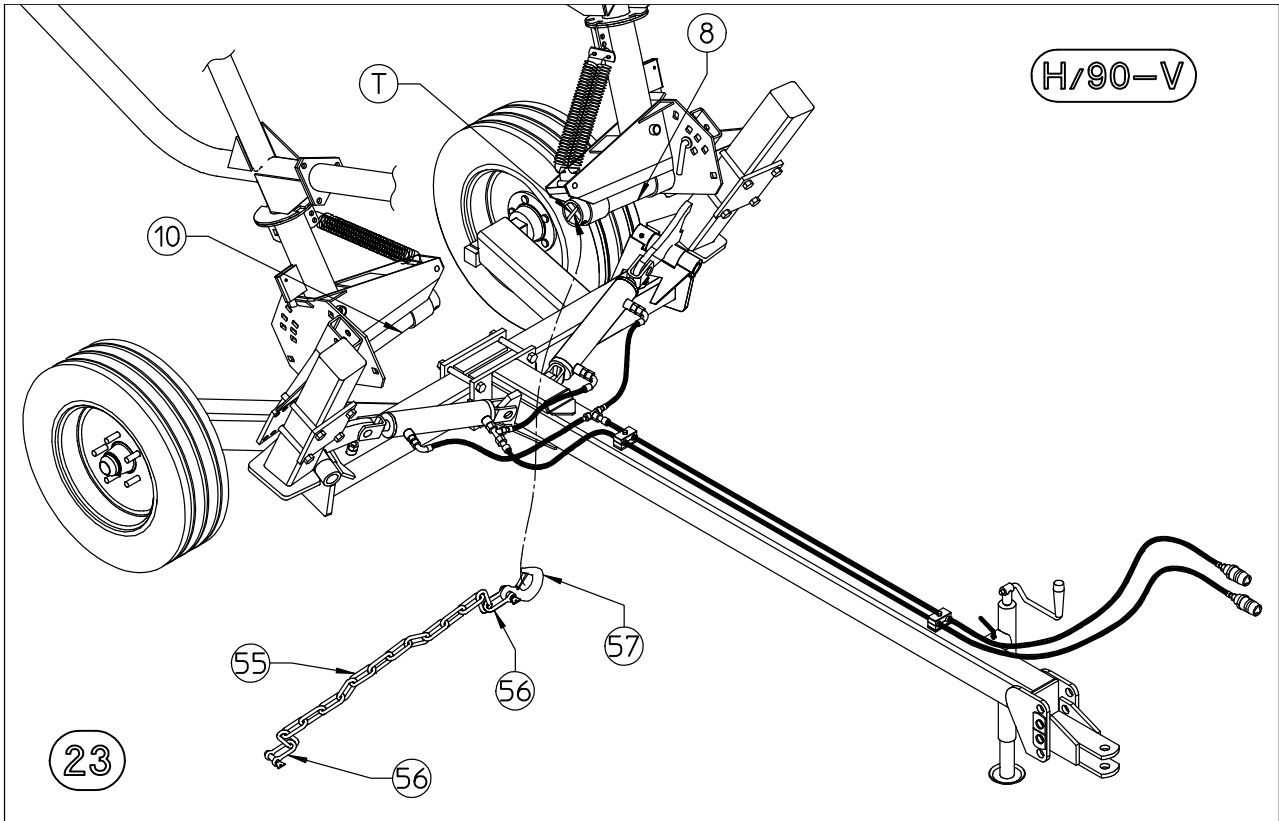

While transporting the machine, the safety locks must always be locked, and while working, the safety locks must always be unlocked

TROUBLES	CAUSES	REMEDIES
1) Wheel does not unload hay.	1) New tine, too much paint on it.	1) Have the wheels be turning on gravelly soil until the tine is clean again.
	2) Mud on tine point due to moist soil.	2) The wheels are too close to the ground.
2) Tine failure.	1) Going backwards with wheels not lifted.	1) Lift the wheels before going backwards.
	2) Too much pressure on the wheels.	2) Lightly lift the rake.
	3) Tine rusted.	3) Protect it by oiling.
3) The rake does not collect the hay.	1) Tine worn out.	1) Replace it. We recommend to replace all tines for uniform height.
4) Too much floating of wheels.	1) Wheels too far from ground.	1) Lightly lower the rake.
5) Bent tine.	1) Going backwards with the wheels not lifted.	1) Lift the wheels before going backwards.
	2) Too much speed on rough soil.	2) Reduce speed.
	3) Going across deep and narrow ditches or prominences.	3) Reduce speed.
	4) Too much weight on the wheels.	4) Lightly lift the rake.

MAINTENANCE

The machine has only two greasing points as shown in relevant picture. No maintenance is required for all bearings, wheel hubs (equipped with 1st quality taper roller bearings and protected with a dust cover) and all setting operations. No special tools are therefore required for servicing.

However, when the season is over, we recommend to clean the implement, to protect it from rust by oiling and store it until next season.

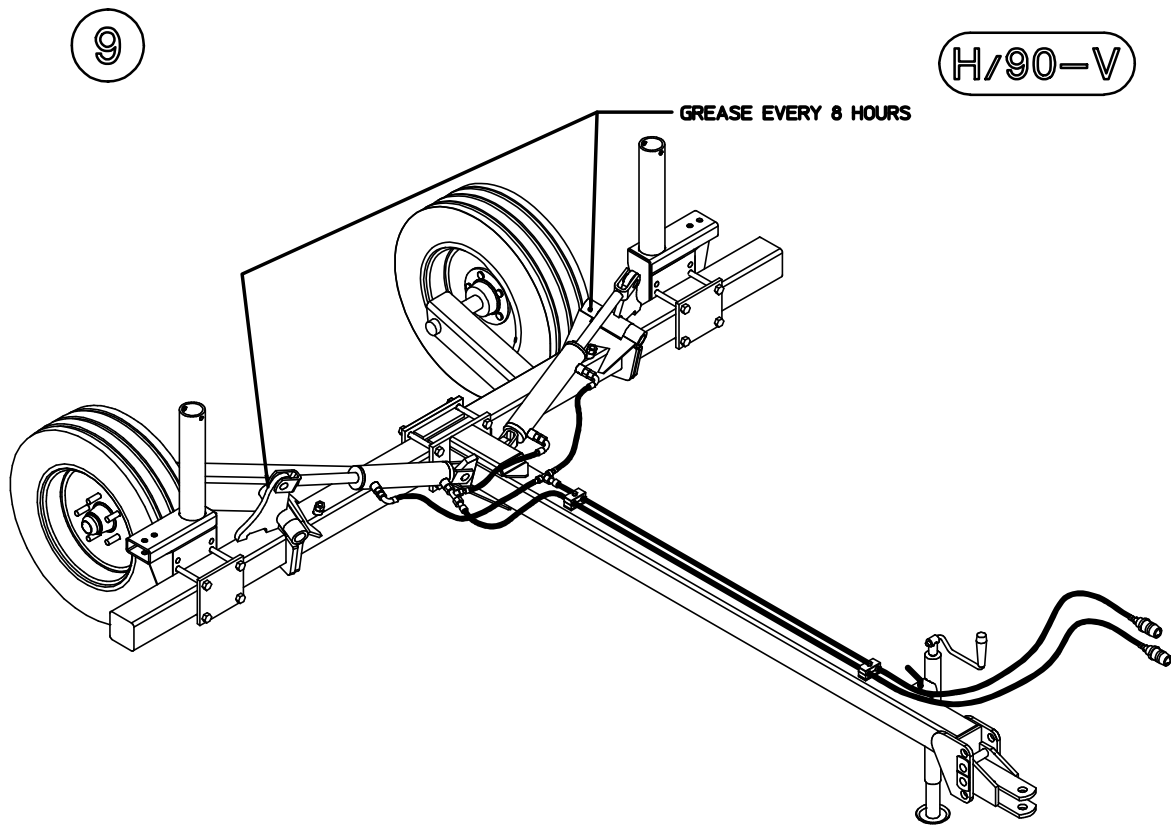

TABLE NO. 920.091

H90-V

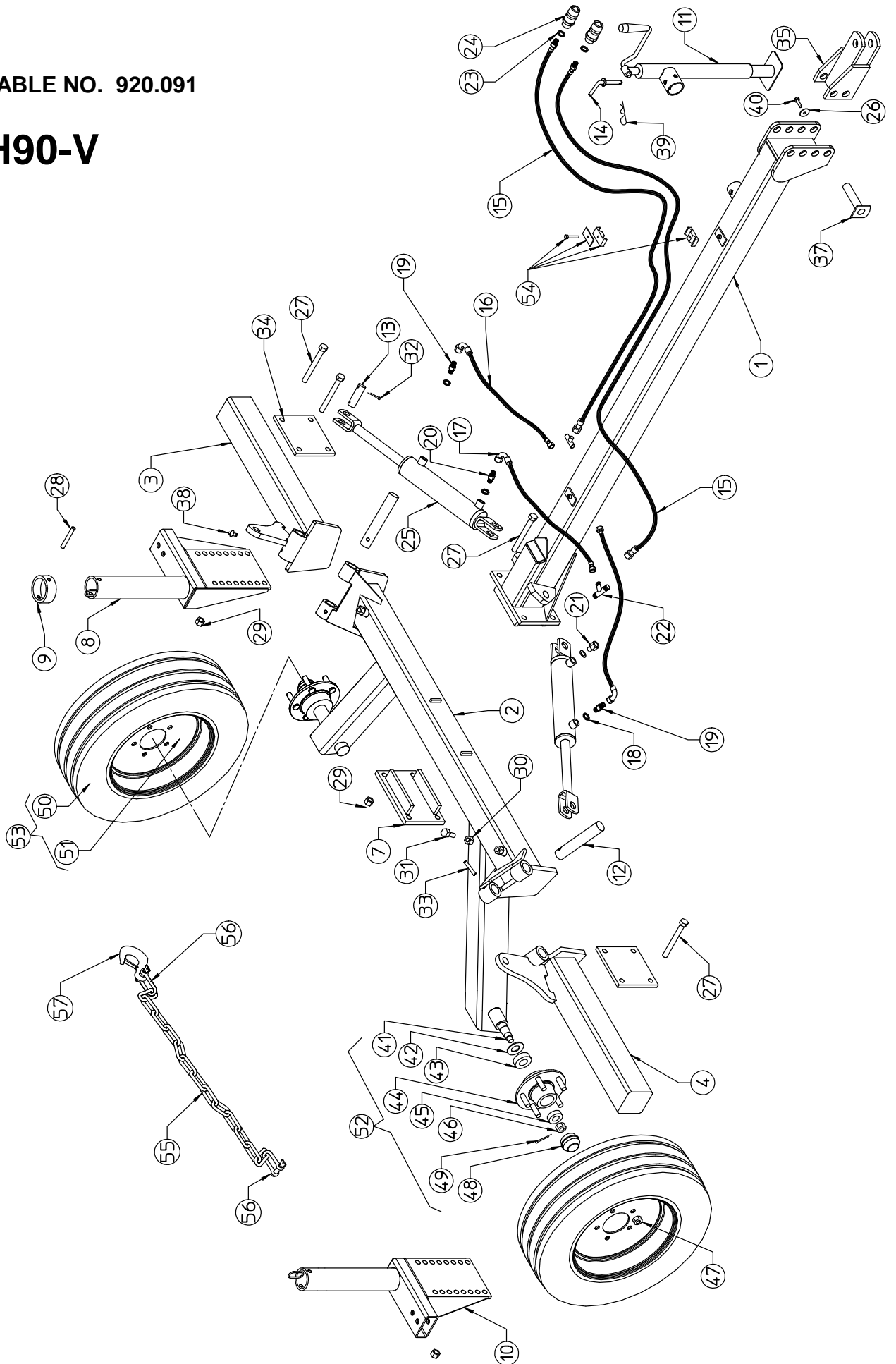

TABLE NO. 920.091

H/90-V

ITEM	Q.ty	PART/NO	DESCRIPTION	NOTE
1	1	210.534	Drawbar	
2	1	210.533	Cart frame	Old style
2	1	220.049	Cart frame	New style
3	1	200.163	L. H. Arm	
4	1	200.164	R. H. Arm	
7	1	210.538	Plate	
8	1	210.532	L.H. base	
9	2	210.539	Bush	
10	1	210.540	R.H. base	
11	1	220.197	Parking stand	
12	2	200.202	Hinge pin	
13	4	200.032	Cylinder pin	
14	1	200.222	Pin	
15	2	600.276	Hose SAE100 R1AT 3/8 FD 3/8 - M 1/2	
16	2	600.275	Hose SAE100 R1AT 3/8 FD 3/8 - F90 3/8	
17	1	600.274	Hose SAE100 R1AT 3/8 FD 3/8 - F90 3/8	
18	4	600.039	Copper washer 3/8"	
19	2	200.192	Nipple 3/8" - 3/8" 0,8	
20	1	600.270	Nipple 3/8" - 3/8"	
21	1	600.271	Turning fitting M-F 3/8"	
22	2	600.272	Fitting MM-M 3/8"	
23	2	600.269	Copper washer 1/2"	
24	2	600.273	Rapid couplig 1/2"	
25	2	210.570	Cylinder	
*	*	610.340	Set of gasket	
26	2	600.092	Washer D12 X36	
27	12	600.219	Screw M16 X150 DIN 931 8.8	
28	2	610.269	Spring washer D 12 X 90 DIN 1481	
29	12	600.080	Nut M16 DIN 980	
30	2	600.082	Nut M16 DIN 936 - 8	
31	2	600.035	Screw M16 X 40 DIN 933 8.8	
32	8	600.038	Split pin D 6 X 35 DIN 94 3.6	
33	2	600.027	Spring pin D 8 X 50 DIN 1481	
34	2	215.210	Plate	
35	1	210.542	Bracket	
37	2	200.828a	Pin	
38	2	600.034	Grease nipple M8	
39	1	600.019	Split pin	
40	2	600.770	Screw M12 X 20 DIN 933 8.8	
41	2	205.276	Hub pin	Old style
41	2	215.803	Hub pin	New style
42	2	600.284	Dust cover	
43	2	600.285	Bearing 30208	
44	2	600.286	Hub	
45	2	600.287	Bearing 30206	
46	2	600.288	Nut M27X1,5	
47	10	600.289	Nut M16 X1,5	
48	2	600.290	Cap	
49	2	600.291	Split pin D 4 X 40 DIN 94 3.6	
50	2	600.233	Tire	
51	2	610.290	Rim	
52	2	205.213	Hub assy	Old style
52	2	215.804	Hub assy	New style
53	2	610.270	Tire assy	
54	2	610.050	Hose collar	
55	1	210.842	Chain	
56	2	610.118	"D" Shackles	
57	1	610.970	Eye Hook	

RP/4

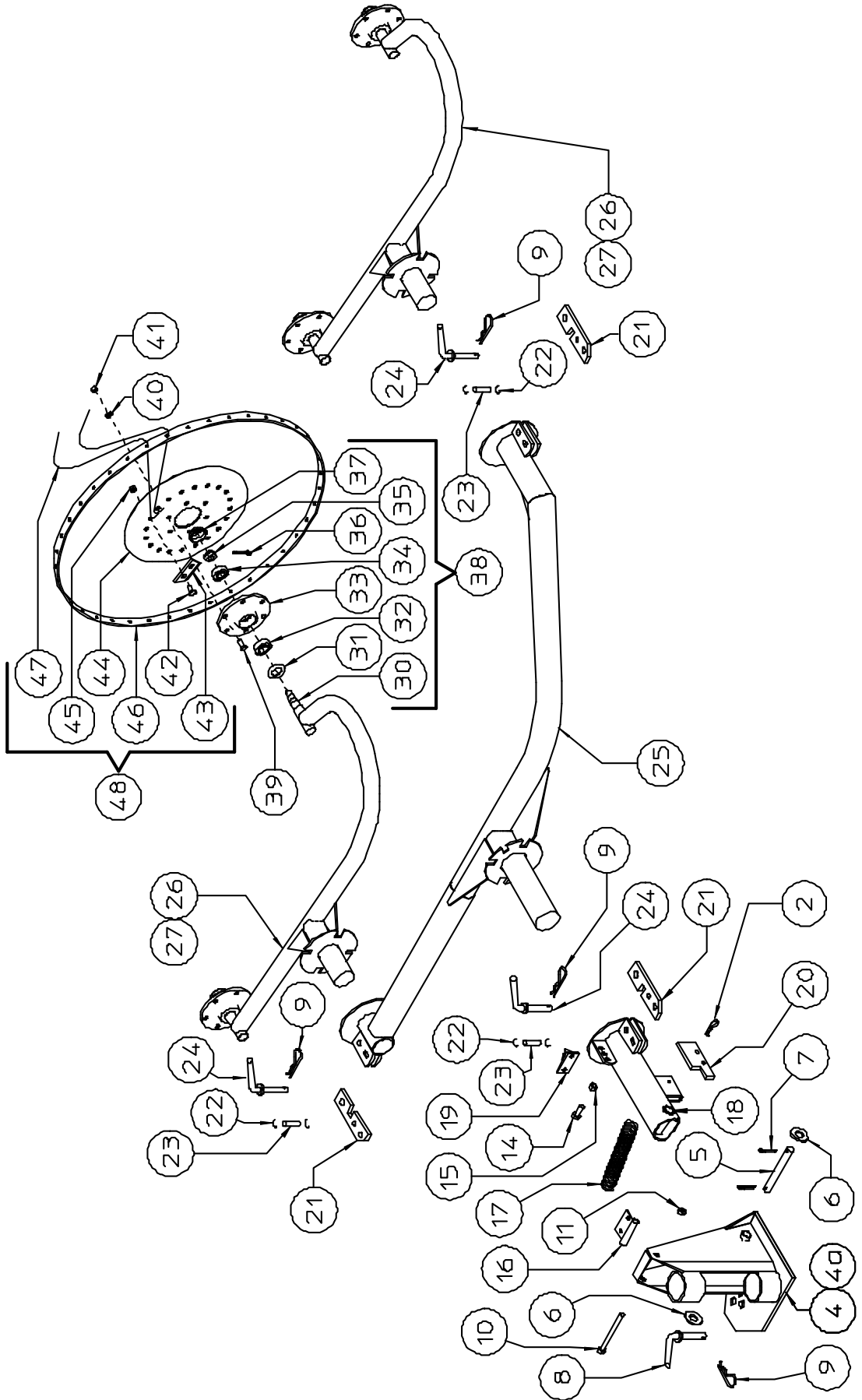

TABLE NO.920.130				
RP/4				
ITEM	Q.ty	PART NO	DESCRIPTION	NOTE
2	2	600.020	SPLIT PIN	
4	1	220.077	SUPPORT R.H.	
4a	1	220.078	SUPPORT L.H.	
5	2	200.067	PIN	
6	4	600.021	WASHER D 23 DIN 125A	
7	4	600.022	SPLIT PIN D6 X 35 DIN 94 3.6	
8	2	200.222	PIN	
9	6	600.019	SPLIT PIN	
10	2	610.018	SCREW M14 X120 DIN 931 8.8	
11	2	600.075	NUT M14 DIN 980	
14	2	600.004	SCREW M12 X 30 DIN 933 8.8	
15	2	600.008	NUT M12 DIN 934 - 8	
16	2	200.068	UPPER LINKAGE, SPRING	
17	4	200.069	SPRING	
18	2	200.071	SWINGING PIPE	
19	2	200.070	LOWER LINKAGE, SPRING	
20	2	200.072	LOCK DEVICE	
21	6	200.073	LEVER	
22	12	600.023	SNAP RING E 15 DIN 471	
23	6	200.074	PIN	
24	6	200.075	PIN	
25	2	210.068	MAIN PIPE	
26	2	200.077	WHEEL ARM, R.H.	
27	2	200.078	WHEEL ARM, L.H.	
30	8	205.277	PIN	
31	8	600.011	DUST COVER	
32	8	600.012	BEARING 30205	
33	8	600.013	WHEEL HUB	
34	8	600.014	BEARING 30204	
35	8	600.015	SELF-LOCKING NUT M18X1,5 - 6	
36	8	600.301	SPLIT PIN D 3 X 30 DIN 94 3.6	
37	8	600.016	SAFETY CAP	
38	8	205.041	HUB ASSY.	
39	48	600.006	SCREW M10 X 25 DIN 933 8.8	
40	48	600.024	SPRING WASHER D 10.5 DIN 127B	
41	48	600.010	NUT M10 DIN 934 - 8	
42	160	600.005	SCREW M10 X 25 DIN 603 6.8	
43	80	200.012	TINE CLAMP	
44	8	200.010	FLANGE	
45	160	600.029	NUT M10 DIN 980	
46	8	200.009	RIM	
47	320	210.621	TINE DIA. 0.276"(7 mm)	
48	8	210.180	WHEEL ASSY., R.H. (TINE DIA.0.276"- 7mm)	
48	8	210.181	WHEEL ASSY., L.H. (TINE DIA.0.276"- 7mm)	

TABLE NO. 920.115

RP/5

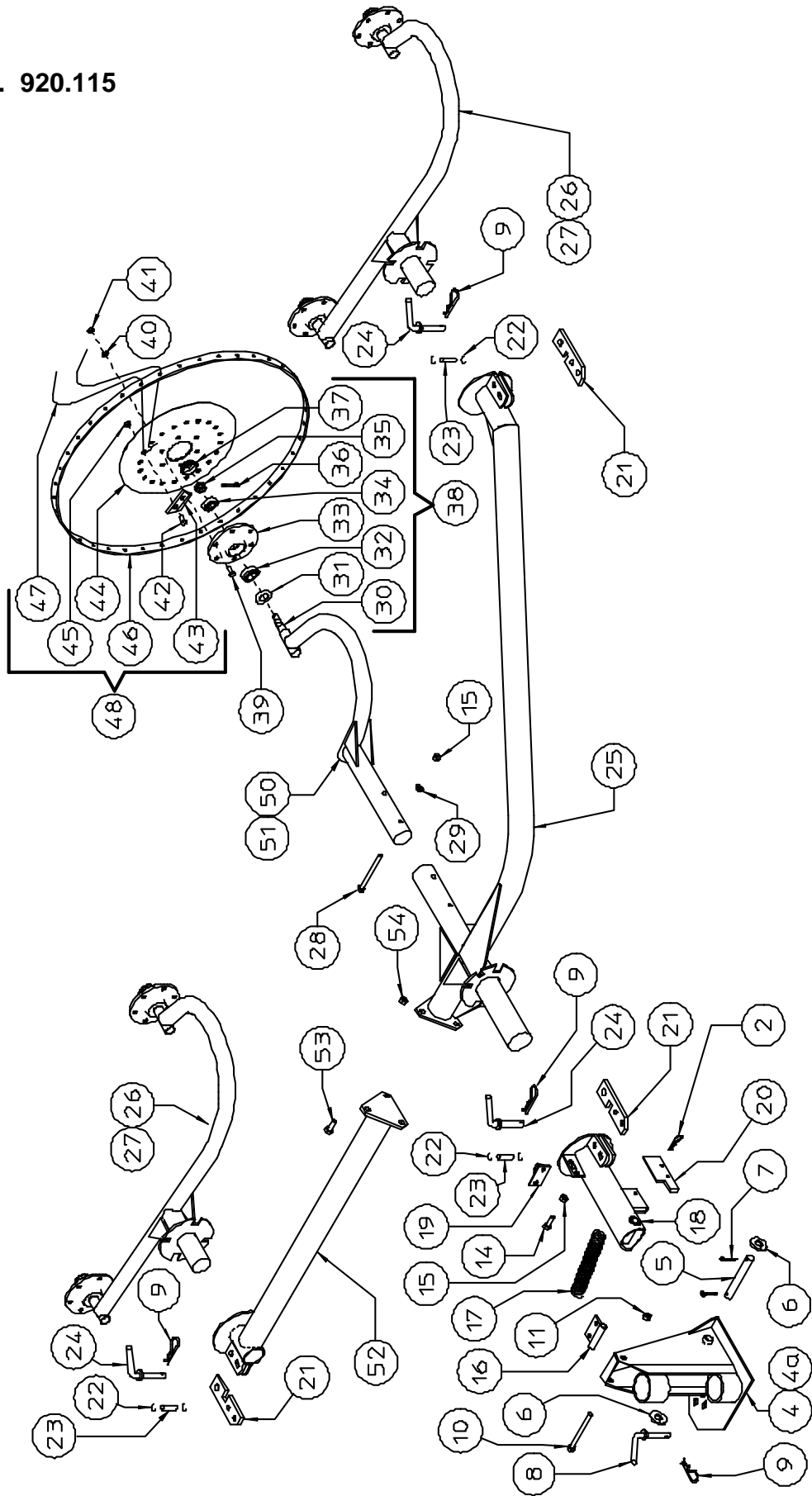

TABLE NO.920.115				
RP/5				
ITEM	Q.ty	PART NO	DESCRIPTION	NOTE
2	2	600.020	SPLIT PIN	
4	1	220.077	SUPPORT R.H.	
4a	1	220.078	SUPPORT L.H.	
5	2	200.067	PIN	
6	4	600.021	WASHER D 23 DIN 125A	
7	4	600.022	SPLIT PIN D 6 X 35 DIN 94 3.6	
8	2	200.222	PIN	
9	8	600.019	SPLIT PIN	
10	2	610.018	SCREW M14 X120 DIN 931 8.8	
11	2	600.075	NUT M14 DIN 980	
14	2	600.004	SCREW M12 X 30 DIN 933 8.8	
15	6	600.008	NUT M12 DIN 934 - 8	
16	2	200.068	UPPER LINKAGE, SPRING	
17	4	200.069	SPRING	
18	2	200.071	SWINGING PIPE	
19	2	200.070	LOWER LINKAGE, SPRING	
20	2	200.072	LOCK DEVICE	
21	6	200.073	LEVER	
22	12	600.023	SNAP RING E 15 DIN 471	
23	6	200.074	PIN	
24	6	200.075	PIN	
25	2	210.199	MAIN PIPE	
26	2	200.077	WHEEL ARM, R.H.	
27	2	200.078	WHEEL ARM, L.H.	
28	4	600.007	SCREW M12 X 85 DIN 931 8.8	
29	4	600018	SPRING WASHER D 13 DIN 127B	
30	10	205.277	PIN	
31	10	600.011	DUST COVER	
32	10	600.012	BEARING 30205	
33	10	600.013	WHEEL HUB	
34	10	600.014	BEARING 30204	
35	10	600.015	SELF-LOCKING NUT M18X1,5 - 6	
36	10	600.301	SPLIT PIN D 3 X 30 DIN 94 3.6	
37	10	600.016	SAFETY CAP	
38	10	205.041	HUB ASSY.	
39	60	600.006	SCREW M10 X 25 DIN 933 8.8	
40	60	600.024	SPRING WASHER D 10.5 DIN 127B	
41	60	600.010	NUT M10 DIN 934 - 8	
42	200	600.005	SCREW M10 X 25 DIN 603 6.8	
43	100	200.012	TINE CLAMP	
44	10	200.010	FLANGE	
45	200	600.029	NUT M10 DIN 980	
46	10	200.009	RIM	
47	400	210.621	TINE DIA.0.276" (7 mm)	
48	10	210.180	WHEEL ASSY, RH (TINE DIA.0.276" 7 mm)	
48	10	210.181	WHEEL ASSY, LH (TINE DIA.0.276" 7 mm)	
50	1	200.079	ARM,RH	
51	1	200.080	ARM, L.H.	
52	2	210.198	PIPE	
53	6	600.310	SCREW	
54	6	600.075	NUT M14 DIN 980	

TABLE NO. 920.129

RP/5

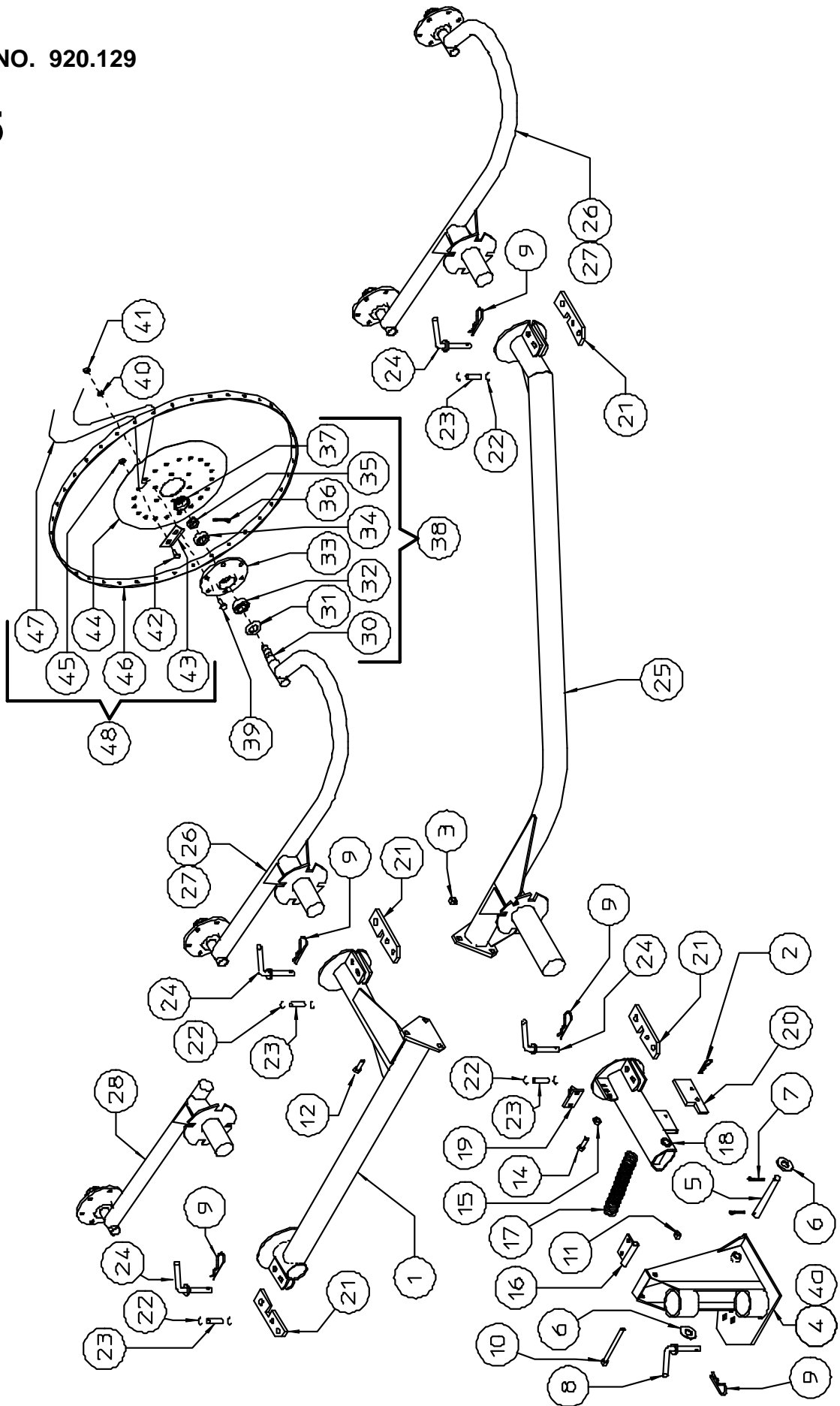

TABLE NO.920.129				
RP/5				
ITEM	Q.ty	PART NO	DESCRIPTION	NOTE
1	1	210.575	PIPE	
2	2	600.020	SPLIT PIN	
3	8	600.075	NUT M14 DIN 980	
4	1	220.077	SUPPORT R.H.	
4a	1	220.078	SUPPORT L.H.	
5	2	200.067	PIN	
6	4	600.021	WASHER D 23 DIN 125A	
7	4	600.022	SPLIT PIN	
8	2	200.222	PIN	
9	10	600.019	SPLIT PIN	
10	2	610.018	SCREW M14 X120 DIN 931 8.8	
12	6	600.310	SCREW M14 X 40 DIN 933 8.8	
14	2	600.004	SCREW M12 X 30 DIN 933 8.8	
15	2	600.008	NUT M12 DIN 934 - 8	
16	2	200.068	UPPER LINKAGE, SPRING	
17	4	200.069	SPRING	
18	2	200.071	SWINGING PIPE	
19	2	200.070	LOWER LINKAGE, SPRING	
20	2	200.072	LOCK DEVICE	
21	8	200.073	LEVER	
22	16	600.023	SNAP RING E 15 DIN 471	
23	8	200.074	PIN	
24	8	200.075	PIN	
25	2	210.576	MAIN PIPE	
26	2	200.077	WHEEL ARM, R.H.	
27	2	200.078	WHEEL ARM, L.H.	
28	2	210.067	ARM	
30	10	205.277	PIN	
31	10	600.011	DUST COVER	
32	10	600.012	BEARING 30205	
33	10	600.013	WHEEL HUB	
34	10	600.014	BEARING 30204	
35	10	600.015	SELF-LOCKING NUT M18X1,5 - 6	
36	10	600.301	SPLIT PIN	
37	10	600.016	SAFETY CAP	
38	10	205.041	HUB ASSY.	
39	60	600.006	SCREW M10 X 25 DIN 933 8.8	
40	60	600.024	SPRING WASHER D 10.5	
41	60	600.010	NUT M10 DIN 934 - 8	
42	200	600.005	SCREW	
43	100	200.012	TINE CLAMP	
44	10	200.010	FLANGE	
45	200	600.029	NUT M10 DIN 980	
46	10	200.009	RIM	
47	400	210.621	TINE DIA.0.276" (7 mm)	
48	10	210.180	WHEEL ASSY., R.H.(TINE DIA.0.276" 7 mm)	
48	10	210.181	WHEEL ASSY., L.H.(TINE DIA.0.276" 7 mm)	

TABLE PART NO 920.247

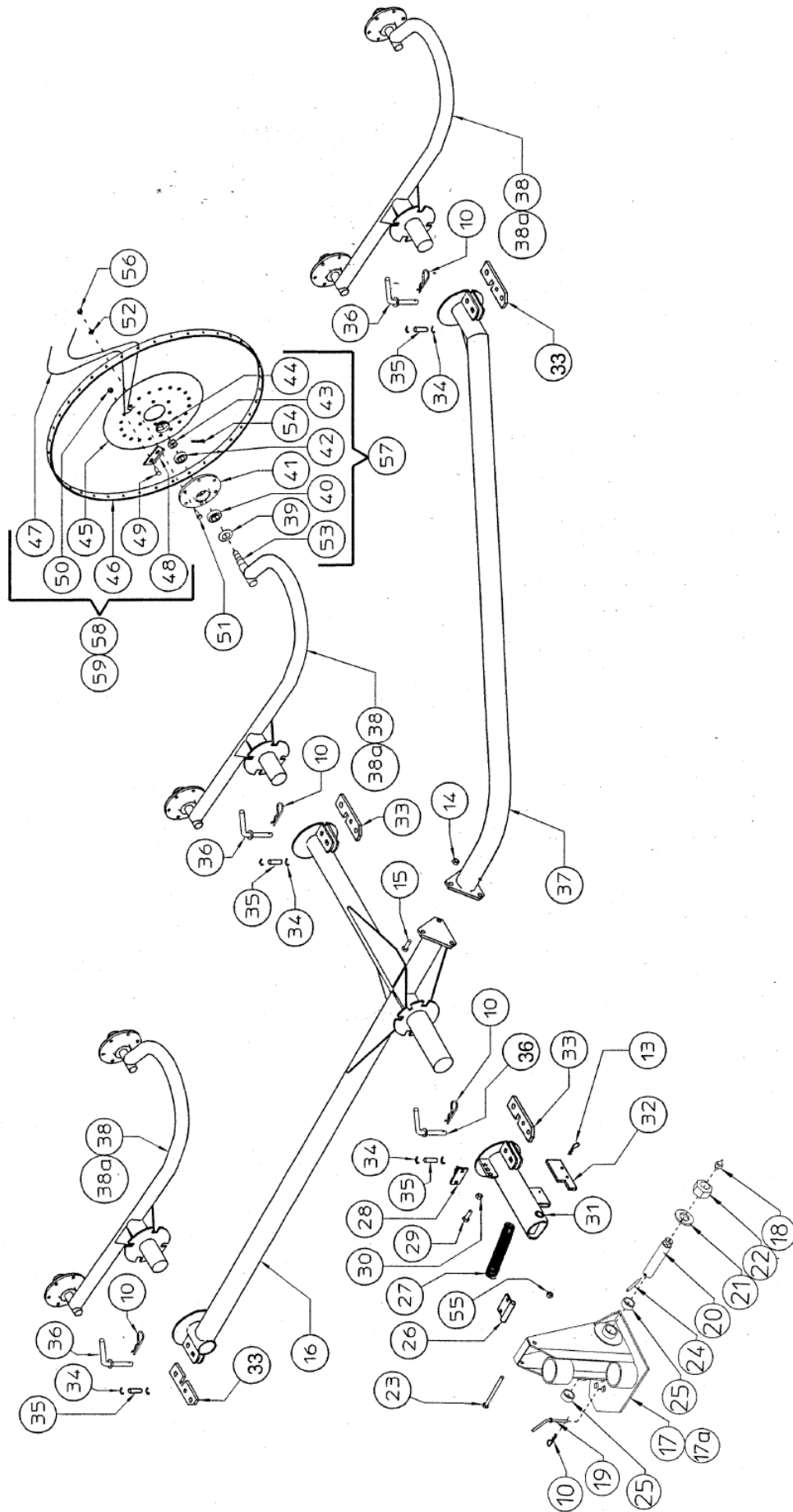

TABLE PART NO 920.247				
ITEM	Q.ty	PART NO	DESCRIPTION	NOTE
10	10	600.019	SPLIT PIN	
13	2	600.020	SPLIT PIN	
14	6	600.075	NUT M14 DIN 980	
15	6	600.310	SCREW M14x40 DIN 933 8.8	
16	2	210.613	PIPE	
17	1	230.172	RH SUPPORT	
17a	1	230.173	LH SUPPORT	
18	2	600.034	GREASE NIPPLE M8	
19	2	200.222	PIN	
20	2	230.203	PIN	
21	2	600.245	WAHER ø25	
22	2	600.725	NUT M24	
23	2	610.018	SCREW M14x120 DIN 931 8.8	
24	2	620.629	SPRING PIN ø8x55	
25	4	600.808	BUSH	
26	2	200.121	UPPER LINKAGE, SPRING	
27	4	300.015	SPRING	
28	2	200.122	LOWER LINKAGE, SPRING	
29	2	600.004	SCREW M12x30 DIN 933 8.8	
30	2	600.052	NUT M12 DIN 934	
31	2	230.171	SWINGING PIPE	
32	2	200.072	LOCK DEVICE	
33	8	200.073	LEVER	
34	16	600.023	SNAP RING E 15 DIN 471	
35	8	200.074	PIN	
36	8	200.075	PIN	
37	2	210612	MAIN PIPE	
38	3	200.077	RH WHEEL ARM	
38a	3	200.078	LH WHEEL ARM	
39	12	600.011	DUST COVER	
40	12	600.012	BEARING 30205	
41	12	600.013	WHEEL HUB	
42	12	600.014	BEARING 30204	
43	12	600.015	NUT M18x1,5	
44	12	600.016	SAFETY CAP	
45	12	200.010	FLANGE	
46	12	200.009	RIM	
47	480	210.621	TINE ø0,276"-7 mm	
48	120	200.012	TINE CLAMP	
49	240	600.005	SCREW M10x25 DIN 603 6.8	
50	240	600.029	NUT M10 DIN 980	
51	120	600.006	SCREW M10x25 DIN 933 8.8	
52	120	600.024	SPRING WASHER ø10,5 DIN 127B	
53	12	205.277	PIN	
54	12	600.301	SPLIT PIN	
55	2	600.075	NUT M14 DIN 980	
56	120	600.010	NUT M10 DIN 934	
57	12	205.041	HUB ASSY	
58	6	210.180	RH WHEEL ASSY (TINE ø0,276")	
59	6	210.181	LH WHEEL ASSY (TINE ø0,276")	

ASSEMBLY KIT TO ATTACH RP/1 TO CART H90

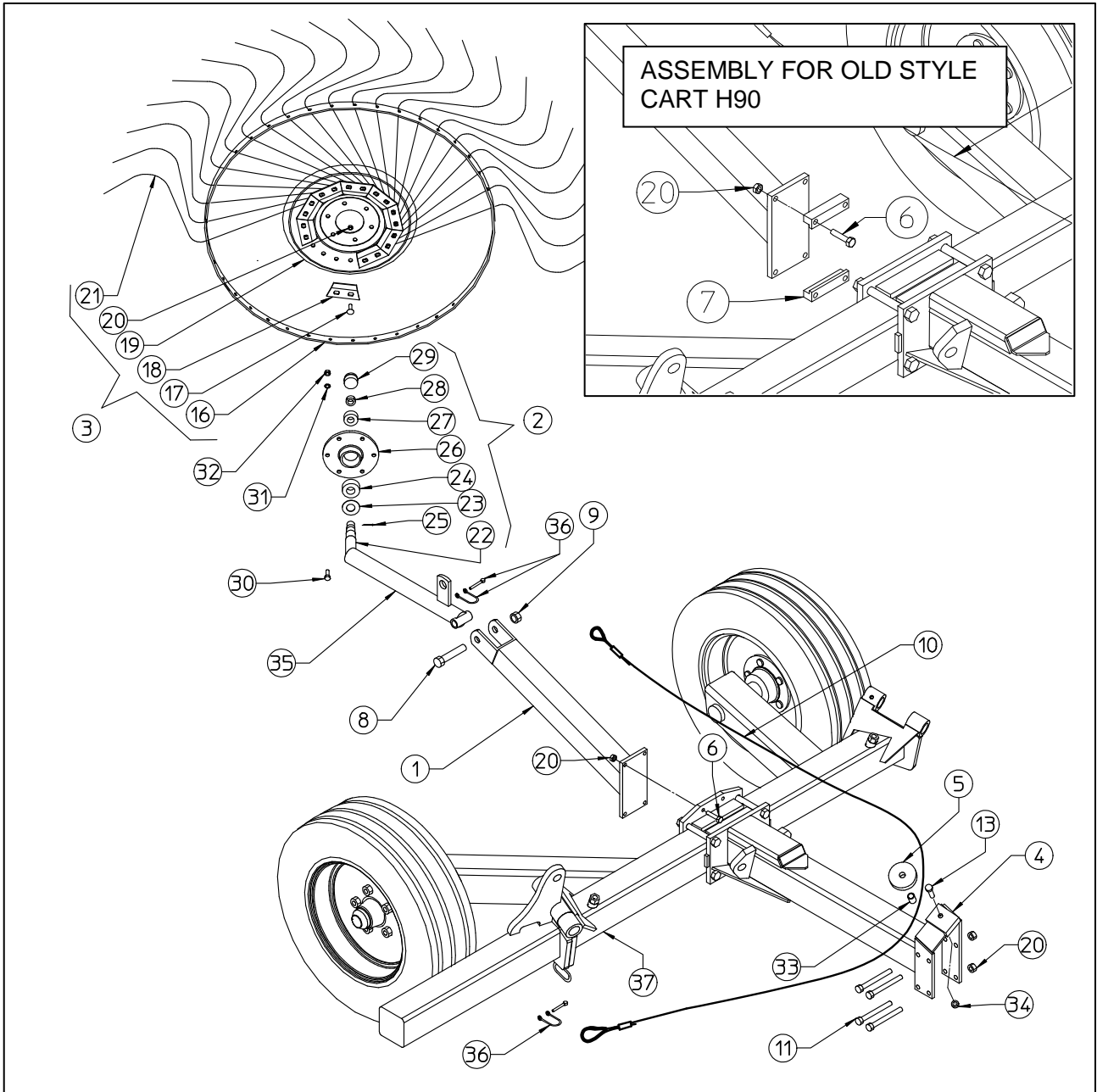
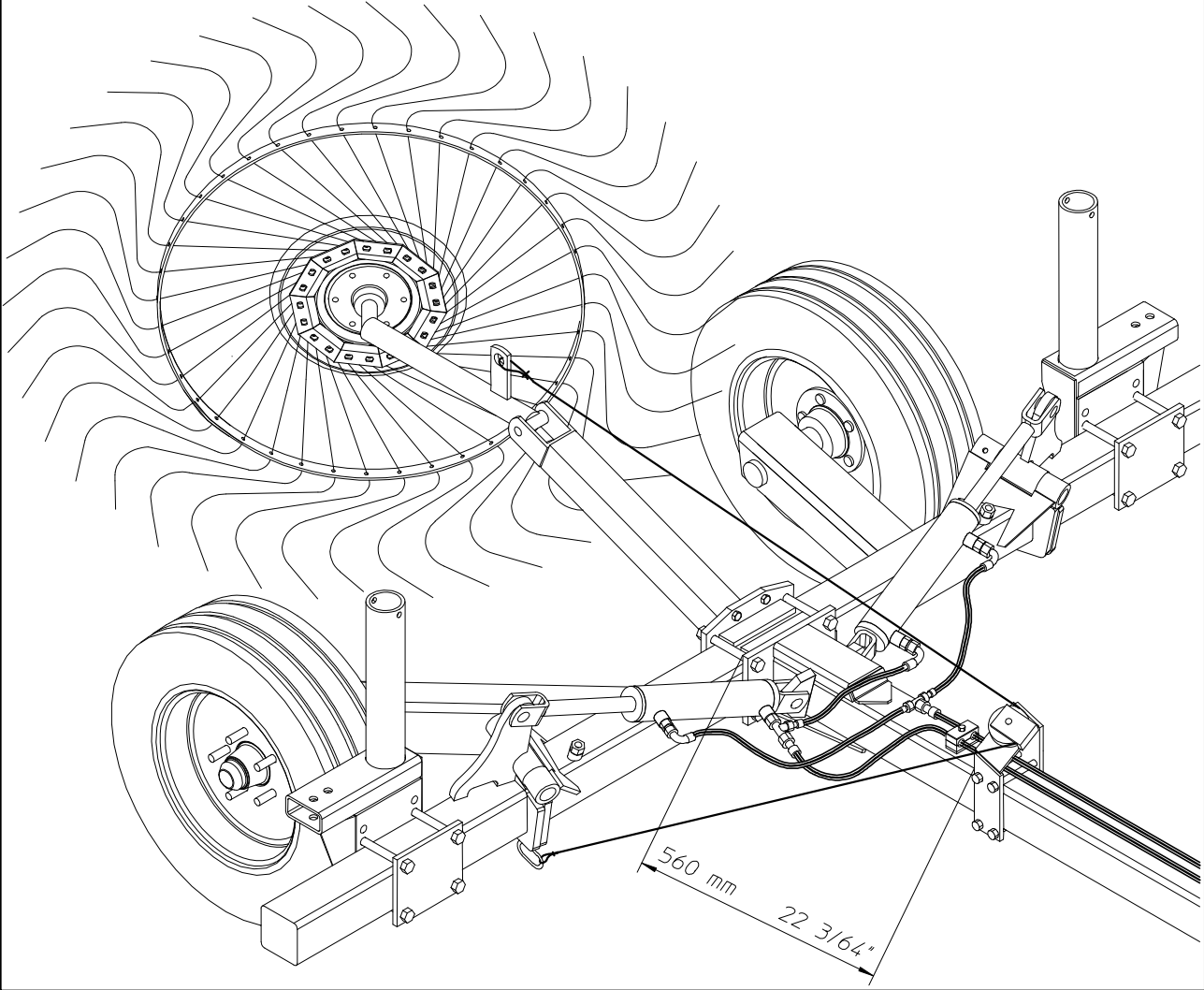

TABLE NO. 920.133 CENTRAL WHEEL KIT				
ITEM	Q.ty	PART NO	DESCRIPTION	NOTE
1	1	220.446	ARM	
2	1	205.041	HUB ASSY	
3	1	210.181	WHEEL ASSY, LH	
4	1	210.580	BRACKET	
5	1	200.741	PULLEY	
6	4	600.439	SCREW M10	
7	2	220.445	WHEEL SUPPORT HITCH	
8	1	600.265	SCREW M18 X100 UNI 5737	
9	1	600.078	NUT	
10	1	200.748	STEEL CABLE	
11	4	610.282	SCREW M10 X130 UNI 5737	
13	1	600.754	SCREW M12 X 55 UNI 5737	
16	1	200.009	RIM	
17	20	600.005	SCREW	
18	10	200.012	TINE LOCK	
19	1	200.010	FLANGE	
20	24	600.029	NUT M10 DIN 980	
21	40	200.011	TINE	
22	1	205.277	PIN	
23	1	600.011	DUST COVER	
24	1	600.012	BEARING	
25	1	600.301	SPLIT PIN	
26	1	205.291	HUB	
27	1	600.014	BEARING	
28	1	600.015	NUT	
29	1	600.016	CAP	
30	6	600.006	SCREW	
31	6	600.024	WASHER	
32	6	600.010	NUT	
33	1	210.581	BUSHING	
34	1	600.077	NUT	
35	1	210.578	HOOK	
36	1	600.761	FORK ASSY	
*	*	210.577	COMPLETE KIT	





AGRICULTURAL MACHINERY
sitrex® Spq .

Zona Industriale-Viale Grecia, 8
06018 TRESTINA-(Perugia)-ITALY
Tel. +39.075.8540021-Telefax +39.075.8540523
e-mail: sitrex@sitrex.it www.sitrex.com

