

ELSTON

Gopher Getters



Parts List for GA-300

Please Contact Us for Parts and Service:

Another Quality Product of:



ELSTON MANUFACTURING INC.

706 N Weber
Sioux Falls, SD 57103
www.elstonmfg.com
1-800-845-1385

Revision C
Updated 2015

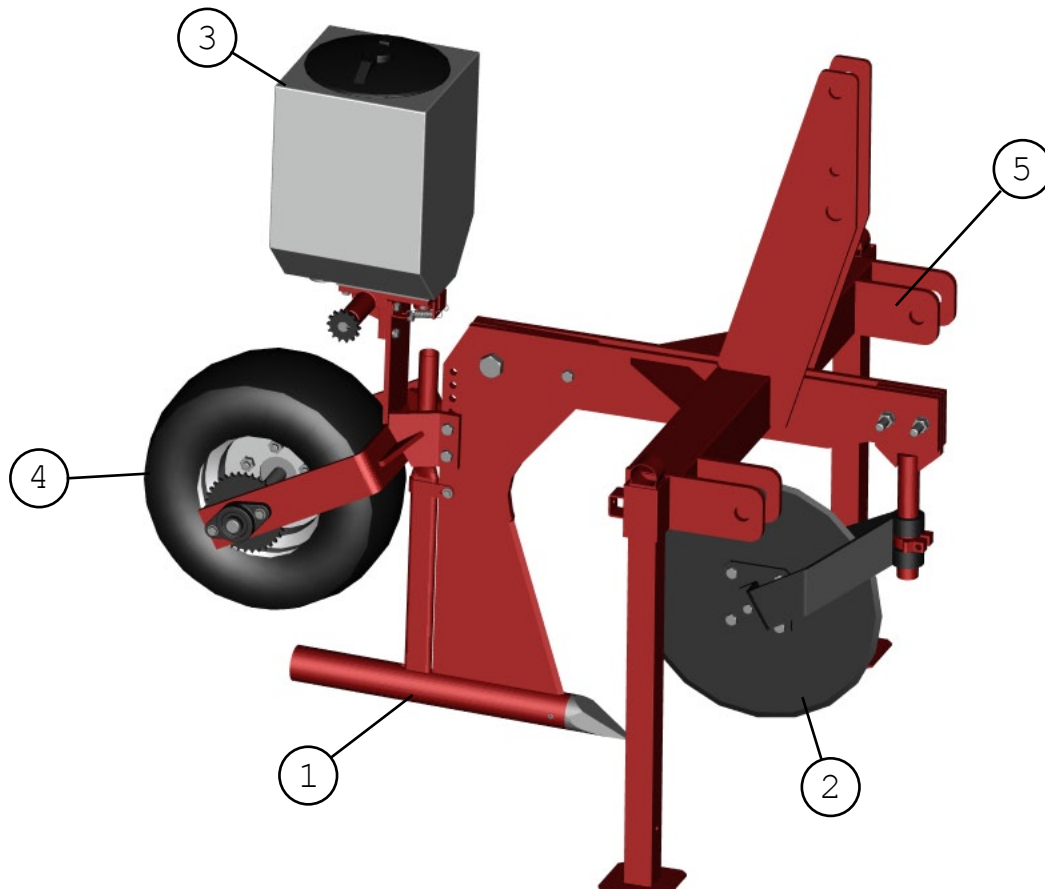

Assemblies

Common Parts

Ref #	Name	Page #	Name	Part #	Page #
1	Knife Assembly	1-2	Torpedo Point	G1-105	1-2
2	Coulter Assembly	1-3	Coulter Blade - 20"	G2-370-20	1-3
3	Seeder Assembly	1-4	Tire	G8-301	1-5
4	Packer Wheel Assembly	1-5	Tripper	G4-269	1-4
5	Frame Assembly	1-6	Knife Assembly (Complete)	G8-100	1-2

Please Call Elston Manufacturing for information on purchasing gopher bait (poison).

Parts List for GA-300

Knife Assembly

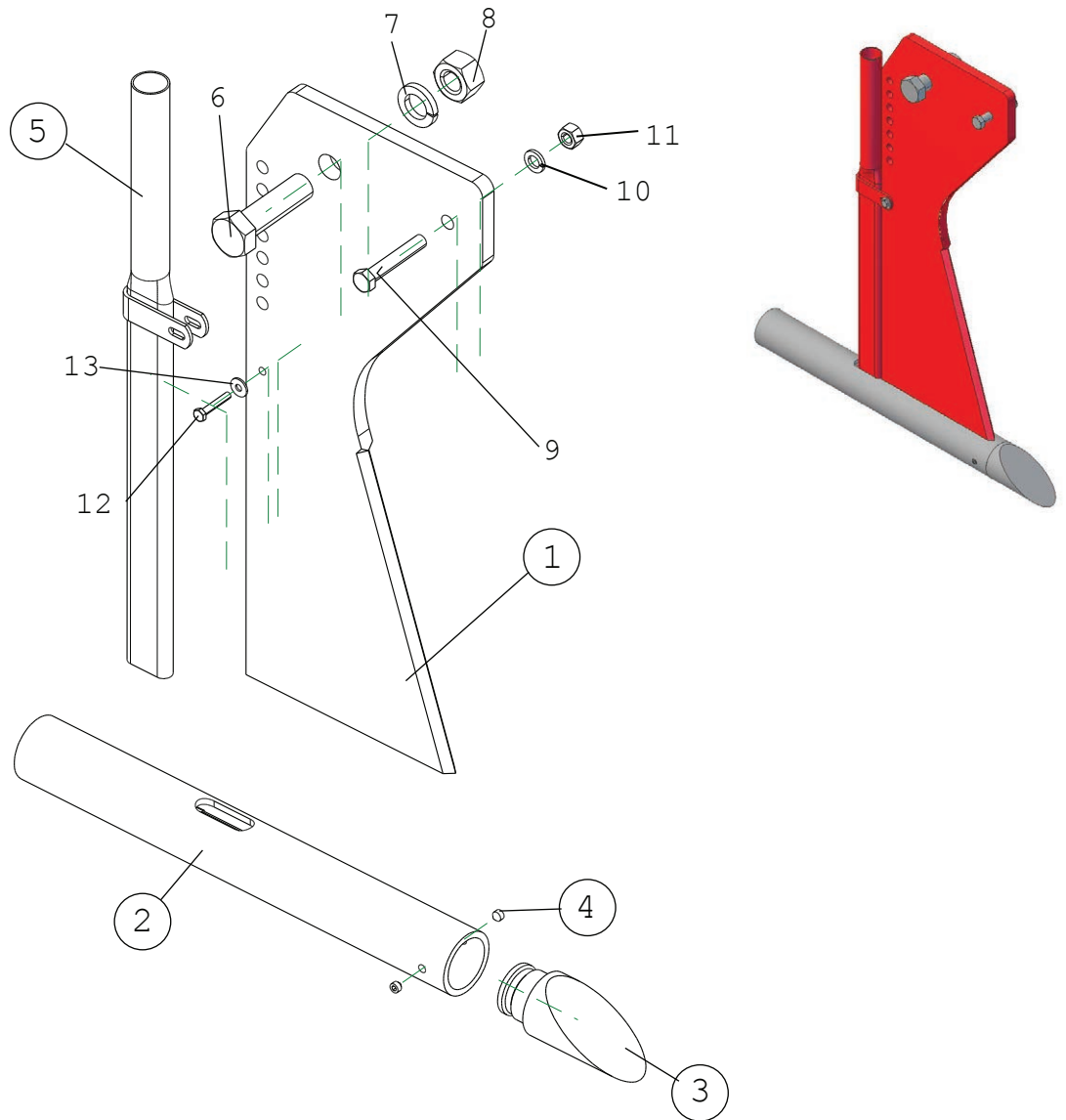

Ref #	Name	Part #	Ref #	Description
1	Knife	G8-101	6	1" x 3 1/2" Hex Head Bolt
2	Torpedo Tube w/ Liner	G8-102	7	1" Lock Washer
3	Torpedo Point	G1-105	8	1" Hex Nut
4	3/8" x 3/8" Set Screw	G1-143	9	1/2" x 3" Hex Head Bolt (Grade 2)*
5	Seeder Tube	G8-103	10	1/2" Lock Washer
1-5, 12-15	Knife Assembly (complete)	G8-100	11	1/2" Hex Nut
			12	1/4" x 1 1/2" Hex Head Bolt
			13	1/4" Flat Washer (One Not Shown)
			14	1/4" Lock Washer (Not Shown)
			15	1/4" Hex Nut (Not Shown)

* This bolt must be grade 2 (or softer). It is designed as a shear bolt to prevent damage when hitting underground obstructions. Using a harder bolt could result in expensive repairs.

All hardware listed is coarse thread (UNC) and Grade 5 or better unless otherwise noted.

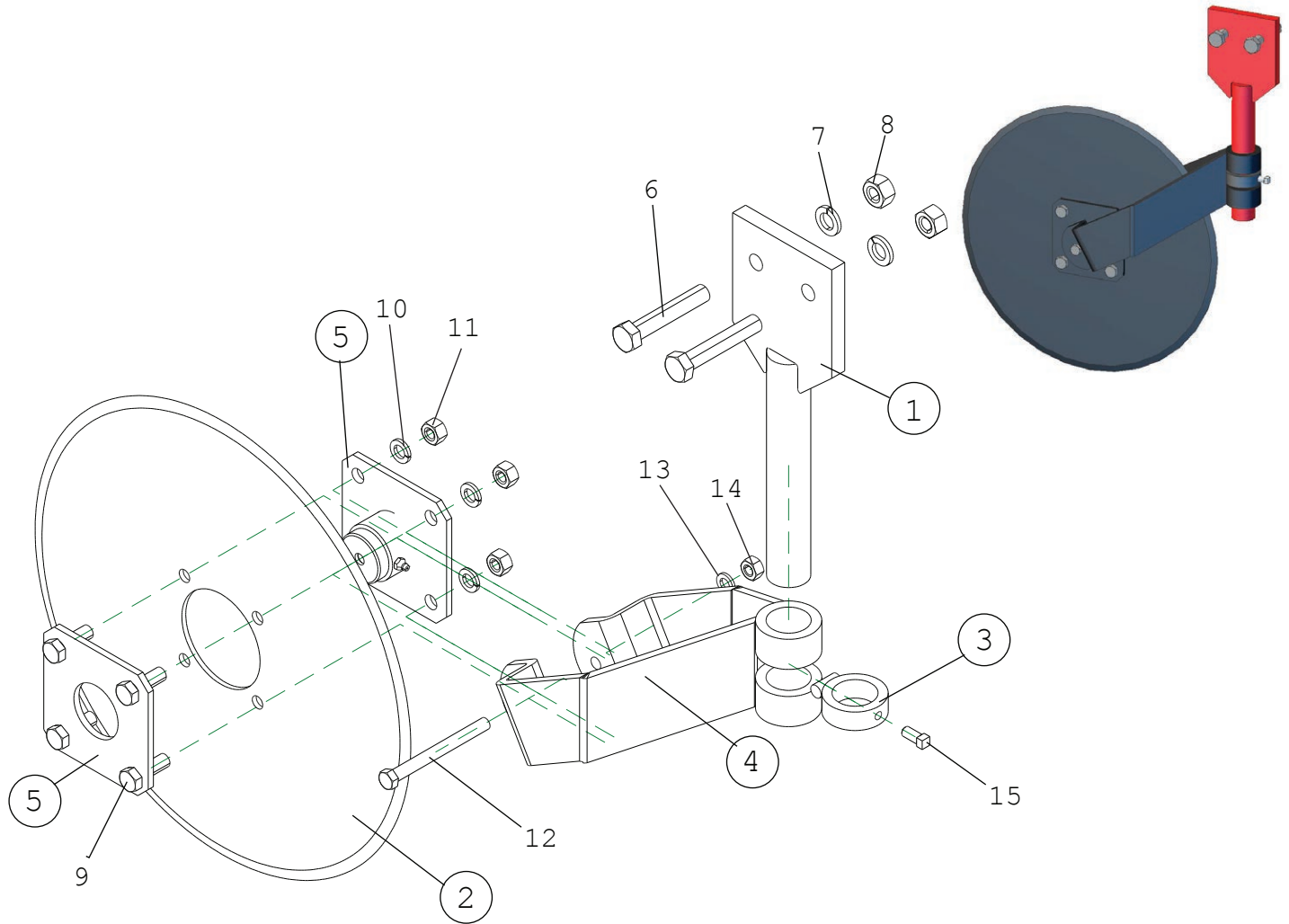

Ref #	Name	Part #	Ref #	Description
1	Coulter Shank	G8-201	6	5/8" x 2 1/2" Hex Head Bolt
2	Coulter Blade - 18"	G2-370-18	7	5/8" Lock Washer
	Coulter Blade - 20"	G2-370-20	8	5/8" Hex Nut
	Coulter Blade - 22"	G2-370-22	9	1/2" x 1 1/2" Hex Head Bolt
3	Coulter Clamp	G2-375	10	1/2" Lock Washer
4	Coulter Side - 18"	G2-380-18	11	1/2" Hex Nut
	Coulter Side - 20"	G2-380-22	12	7/16"-20 4 1/2" Hex Head Bolt
	Coulter Side - 22"	G2-380-22	13	7/16" Lock Washer
5	Coulter Blade Hub	see p. 2-1	14	7/16" Hex Nut
5,9-14	Coulter Hub Assembly	G2-379	15	3/8"-16 x 1" Square Hd Set Screw
2,5,9-14	Coulter Blade and Hub Assembly	18" G2-390-18 20" G2-390-20 22" G2-390-22		
2-5,9-15	Coulter Assembly	18" G2-100-18 20" G2-100-20 22" G2-100-22		

All hardware listed is coarse thread (UNC) and Grade 5 or better unless otherwise noted.

Parts List for GA-300

Seeder Assembly

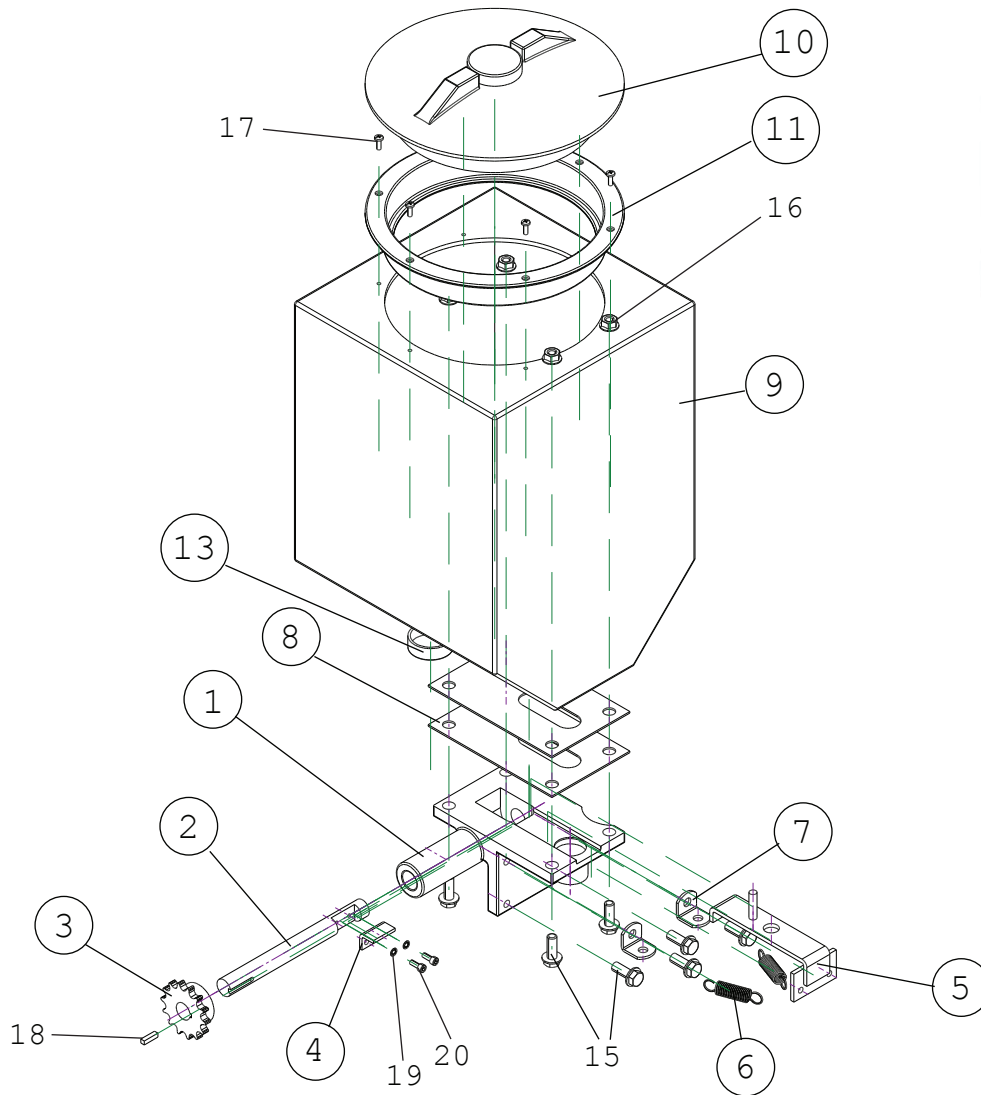

Ref #	Name	Part #
1	Seeder Casting	G4-200
2	Seeder Axle	G4-201
3	Drive Gear	G4-203
4	Tripper	G4-269
5	Seeder Slide - 5/8" Hole for 7/8" Hole use G4-208A	G4-208
6	Seeder Slide Spring	G4-215
7	Spring Holder Clip	G4-278
8	Guide Plate - Long Slot Short Slot	G4-286 G4-286A
9	Seeder Box	G4-230P
10	Seeder Box Lid	G4-234P
12	Lid Retaining Strap (Not Shown)	G4-233P
10-12	Seeder Box Lid Assembly	G4-231P

Ref #	Name	Part #
13	Drain Cap	G4-221P
14	Plastic Hose (Not Shown)	G4-122
9-13,17	Seeder Box Assembly	G4-235P
1-20	Seeder Assembly	G4-100P

Ref #	Description
15	3/8"-16 x 1" Wislock Hex Bolt
16	3/8"-16 Wislock Hex Nut
17	#8 1/2" Sheet Metal Screw
18	9/16" of 3/16" Square Key Stock
19	#10 Internal Locking Washer
20	#10-24 1/2" Allen Screw (Use LocTite)

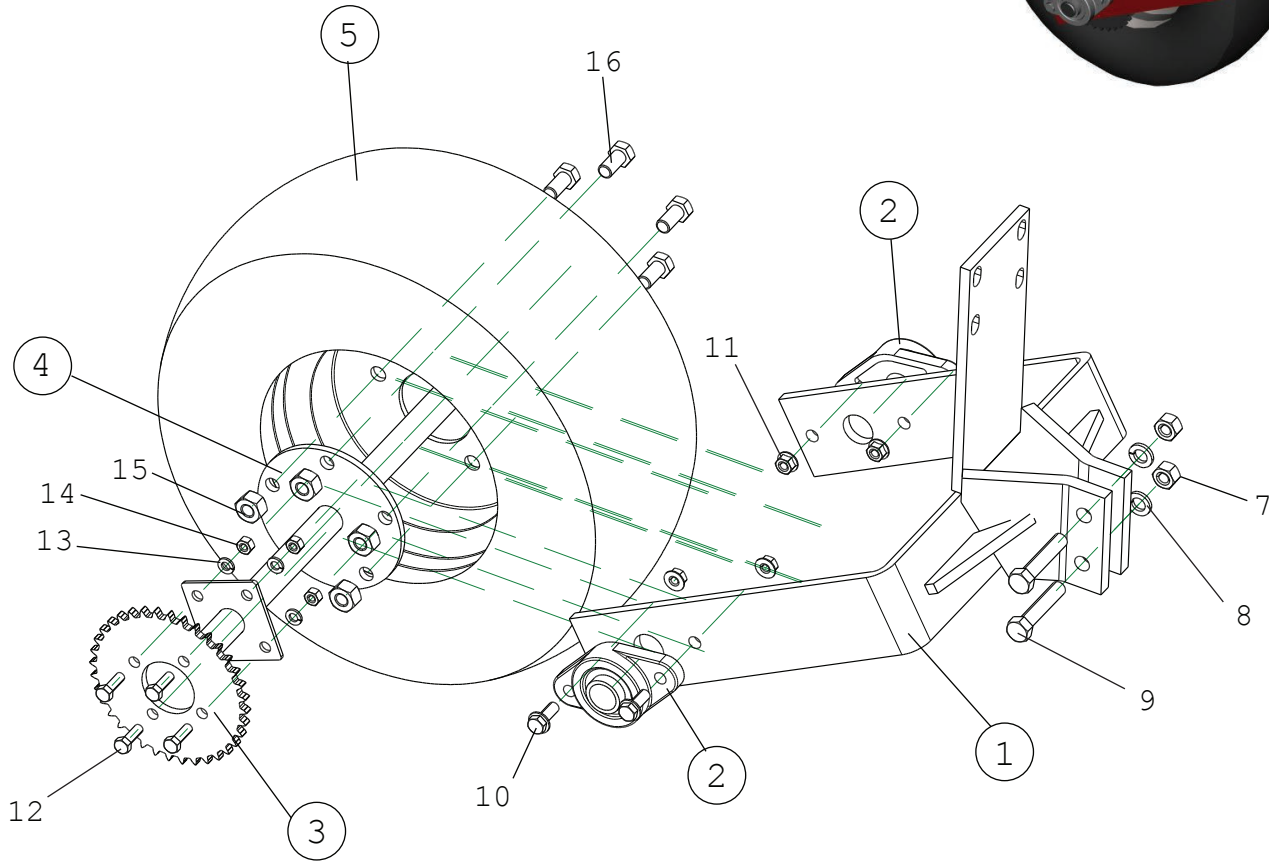
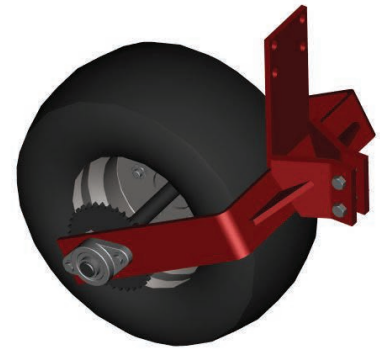

Ref #	Name	Part #	Ref #	Description
1	Packer Wheel Bracket	G8-305	7	1/2" Hex Nut
2	Packer Wheel Bearing	G8-303	8	1/2" Lock Washer
3	Large Sprocket	G8-306	9	1/2" x 2 1/2" Hex Head Bolt
4	Packer Wheel Inner Axle Assy	G8-302	10	3/8" x 1" Wislock Hex Head Bolt
5	Packer Wheel (Tire and Rim) - 18.5 x 8.5 - 8 LRC	G8-301	11	3/8" Wislock Hex Nut
6	Chain (Not Shown)	G8-304	12	5/16" x 1" Hex Head Bolt
1-6, 10-16	Packer Wheel Assembly	G8-300	13	5/16" Lock Washer
			14	5/16" Hex Nut
			15	Wheel Nut
			16	1/2" UNF x 1" Hex Head Bolt

All hardware listed is coarse thread (UNC) and Grade 5 or better unless otherwise noted.

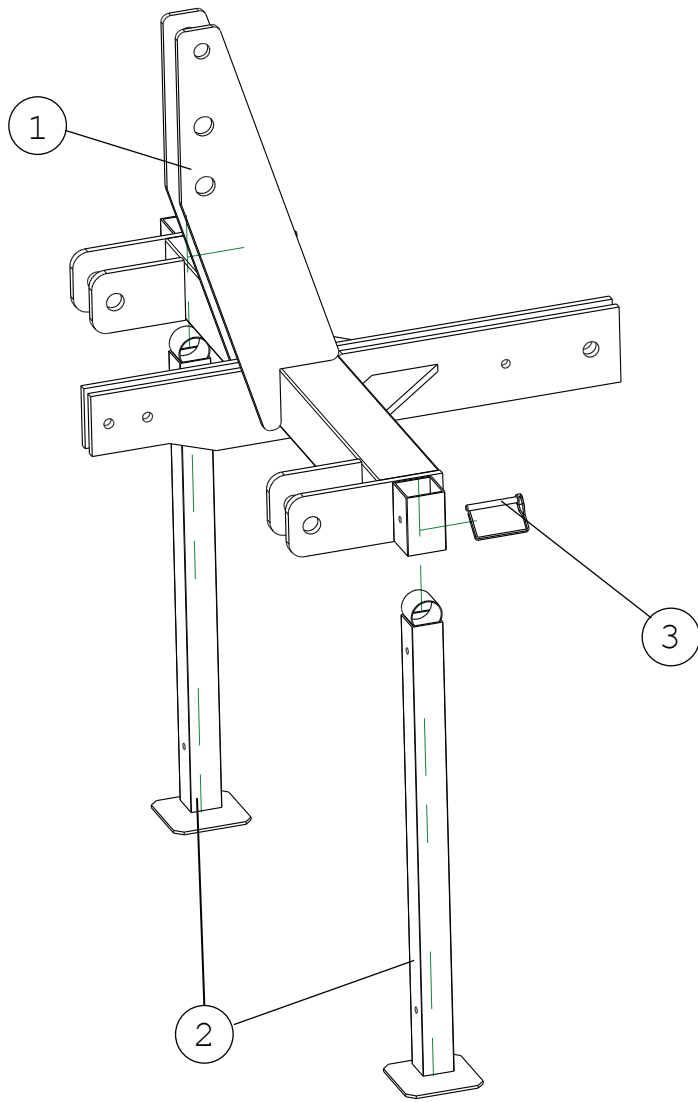

Ref #	Name	Part #	Ref #	Description
1	Frame	G8-501		
2	Leg	G8-502		
3	Snap Pin	G7-526		

Coulter Blade Hub

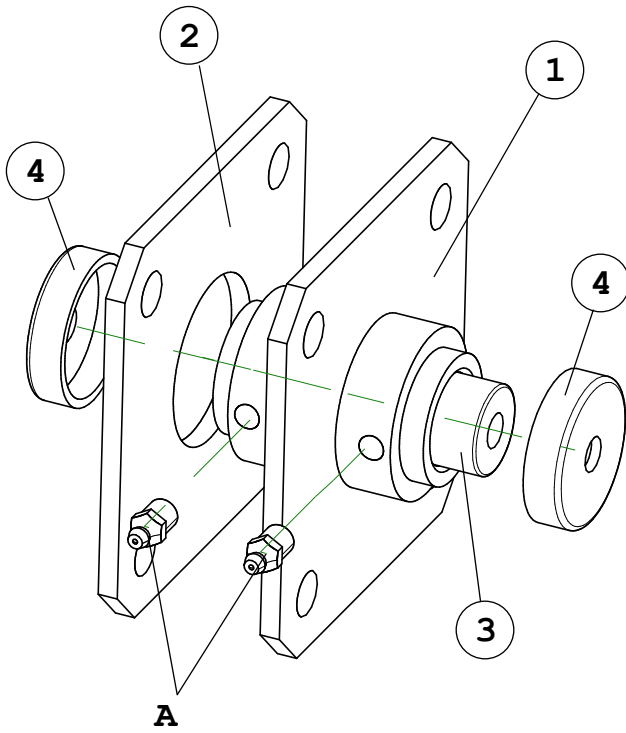

Label	Name	Part #
1	Blade Flange w/ Hub	G2-381
2	Blade Flange	G2-382
3	Inner Bearing	G2-383
4	Bearing Cap	G2-384
A	1/4"-28 SAE-LT Grease Fitting	N/A*

*Not Available Separately