



DANUSER®

Agricultural and Industrial Attachments

EP AUGER SYSTEM

EP

615 • 1020 • 1530 • 2035



"Good enough won't do - it must be right." - K.B. Danuser, Founder 1910

**GENERAL
IMPLEMENT**
DISTRIBUTORS

1-800-368-3688

DRIVE UNITS

EP615			
Output Speed		Output Torque	
GPM	RPM	PSI	FT.-LBS.
6	36	2500	1267
		3000	1520
		3500	1774
8	48	2500	1267
		3000	1520
		3500	1774
10	60	2500	1267
		3000	1520
		3500	1774
12	73	2500	1267
		3000	1520
		3500	1774
14	85	2500	1267
		3000	1520
		3500	1774
15	91	2500	1267
		3000	1520
		3500	1774

Max. Auger Dia: 24"
Hyd. Flow: 6-15 GPM
Max. Hyd. PSI: 3500

Gearbox Ratio: 3.86:1
2" Hex
No Case Drain Req'd.

EP1020			
Output Speed		Output Torque	
GPM	RPM	PSI	FT.-LBS.
10	48	2500	1587
		3000	1904
		3500	2222
12	58	2500	1587
		3000	1904
		3500	2222
14	68	2500	1587
		3000	1904
		3500	2222
15	72	2500	1587
		3000	1904
		3500	2222
18	87	2500	1587
		3000	1904
		3500	2222
20	97	2500	1587
		3000	1904
		3500	2222

Max. Auger Dia: 30"
Hyd. Flow: 10-20 GPM
Max. Hyd. PSI: 3500

Gearbox Ratio: 3.86:1
2" Hex
No Case Drain Req'd.



EP AUGERS



FAB (Light-Duty)

Light to Moderate Ground Conditions
Available Diameters

4", 6", 8", 9", 10", 12", 15", 16", 18",
20", 24", 30", 36"



CAST (Heavy-Duty)

Difficult Ground – Fracturable Rock, Asphalt,
Frozen Ground, Heavy Clay, & Compacted Soils
Available Diameters

6", 8", 9", 10", 12", 15", 16", 18", 20", 24",
30", 36", 42", 48"



BULLET ROCK

Solid Rock, Concrete, Fracturable Rock,
Asphalt, Frozen Ground, & Compacted Soils
Available Diameters

4.5", 6", 8", 9", 10", 12", 15", 18", 24", 30", 36"

NOTE: As with all rock augers, performance depends upon down force and torque applied to the auger.

MOUNTING OPTIONS

To see all mounting options, visit www.danuser.com.



Skid-Steer / Front-End Loader
Quick Attach
Center & Offset



Offset Quick Attach
Front-End Loader Mounts
John Deere 200-500 Series (shown
above), & Euro/Global



Mini-Skid-Steer
Mounts



Backhoe & Excavator
Quick Attach
Mounting Kits



Backhoe & Excavator
Pin-On Mounting



Kits Bolt-On
Bucket

Hose kits and couplers available.

Yellow-shaded areas indicate recommended operating ranges.
 Output speed and torque specifications are based on theoretical values and are provided for comparative purposes only.



EP1530			
Output Speed		Output Torque	
GPM	RPM	PSI	FT.-LBS.
15	49	2500	2342
		3000	2811
		3500	3279
18	59	2500	2342
		3000	2811
		3500	3279
20	65	2500	2342
		3000	2811
		3500	3279
24	78	2500	2342
		3000	2811
		3500	3279
28	92	2500	2342
		3000	2811
		3500	3279
30	98	2500	2342
		3000	2811
		3500	3279

Max. Auger Dia: 36"
 Hyd. Flow: 15-30 GPM
 Max. Hyd. PSI: 3500

Gearbox Ratio: 3.86:1
 2" Hex
 No Case Drain Req'd.

EP2035			
Output Speed		Output Torque	
GPM	RPM	PSI	FT.-LBS.
20	48	2500	3161
		3000	3794
		3500	4426
24	58	2500	3161
		3000	3794
		3500	4426
28	68	2500	3161
		3000	3794
		3500	4426
30	73	2500	3161
		3000	3794
		3500	4426
35	85	2500	3161
		3000	3794
		3500	4426

Max. Auger Dia: 36"
 Hyd. Flow: 20-35 GPM
 Max. Hyd. PSI: 3500

Gearbox Ratio: 3.86:1
 2" Hex
 No Case Drain Req'd.

SPECIALTY AUGERS



ROCK DRILL

Pilot holes or setting posts up to 2" O.D. in solid rock



TREE

Tree and Shrub Planting
 Available Diameters
 18" - 9", 24" - 12", 30" - 15"
 36" - 18"



WOBBLE AUGER

Danuser's patented Wobble Auger digs through tough ground conditions without leaving a dirt pile mess at the top or bottom of the hole.

Pushes Through

Dirt Asphalt Embedded Rock
 Sand Compacted Rock Frozen Ground
 Clay

Available Diameters

4", 6", 9"

NOTE: We recommend the 9" Wobble Auger be used on a skid-steer with an Operating Load or Rated Operating Capacity of 2250 lbs. or greater, utilizing an auger drive with 2000 ft. lbs. of torque or greater.

FISHTAIL POINTS



D

HF

C

TEETH

GAGE
 Fab & Cast
 (Outside)



D

HF

WISDOM
 Fab
 (Inside)



D

HF

C

CHISEL
 Cast
 (Inside)



D

HF

C

Dirt = D Hardfaced = HF Carbide = C



AUGER SYSTEM

- ☪ The New EP is built with a Danuser planetary, manufactured to our engineering design, creating a planetary with up to 42% more output torque strength than the competition.
- ☪ Compatible with 2" hex auger bits.
- ☪ Hoses routed out the top of the drive unit, secured with bulkhead nuts, allow for deeper digging in tighter spots with better hose protection. All drive units ship with 45° fittings installed.
- ☪ Mounts available for skid-steer, mini-skid-steer, front-end loader, backhoe, and excavator.
- ☪ A single skid-steer quick attach mount fits both skid-steers and front-end loaders. Hose holder spring kit included on skid-steer mount and offset tractor loader mounts.
- ☪ All quick attach mounts offer an adjustable cradle with two positions for transporting at 15° or 30° angles.
- ☪ Comes with five-year warranty on drive unit and lifetime warranty covering output spindle pullout.

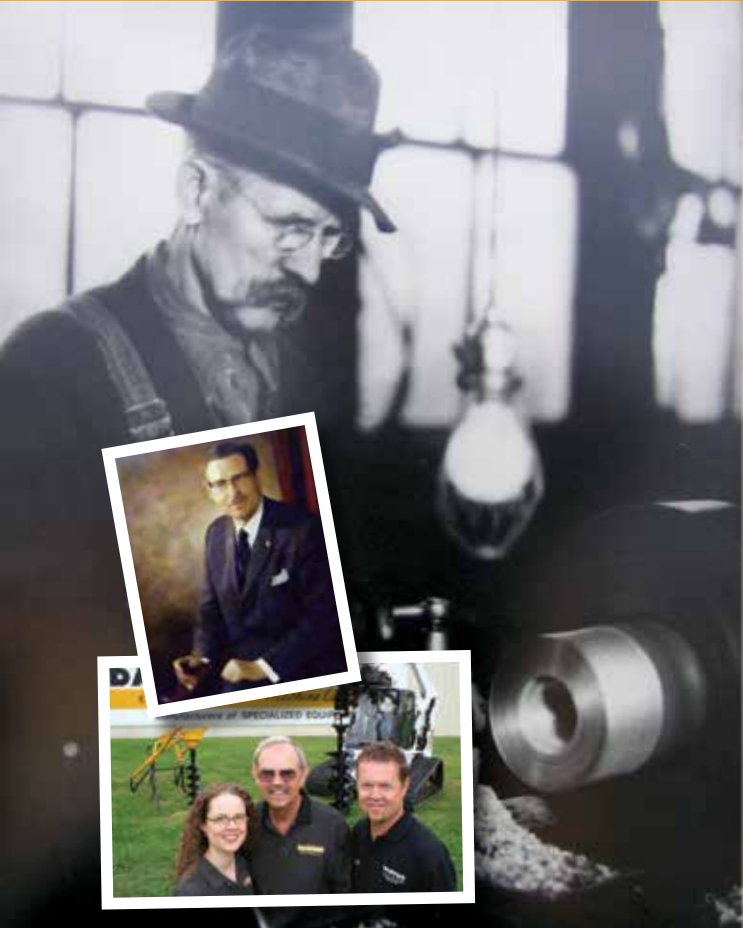

A HISTORY OF INNOVATION

Established in 1910, DANUSER has been family owned and operated by four generations. We have manufactured auger systems since the mid-1940's. With decades of design and manufacturing experience, our machines have stood the test of time. Today our commitment to our customer remains to design and build products that are the benchmark of quality, reliability, and longevity. In the words of our founder K.B. Danuser, "Good enough won't do – it must be right."

DANUSER manufactures several attachments for various equipment, serving several industries worldwide. Please visit www.danuser.com to see our full line of attachments.

Danuser reserves the right to make changes in design, specifications, and prices without notice and without incurring any obligation relating to such changes.

Patent: www.danuser.com/patents





EP AUGER SYSTEMS PRICE SHEET

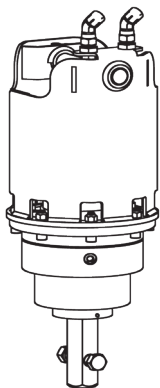

5-Year Warranty

Lifetime covering output pullout

Heavy-duty performance at an exceptional price. Drive units range from 6 - 35 GPM and up to 3500 PSI with 2" hex output spindles. Mounts are available for skid-steer, front-end loader, backhoe, and excavator.

TO PRICE A COMPLETE SYSTEM:

Drive Units	_____
Hoses & Hyd. Accessories	_____
Mounts	_____
Augers & Accessories Freight	_____
TOTAL	_____

⚠ WARNING This product can expose you to chemicals known to the State of California to cause cancer and birth defects or other reproductive harm. For more information go to www.P65Warnings.ca.gov/product.

DRIVE UNITS

MODEL EP615 \$2,240.00

Part No.	180405
Approx. Ship Weight (lbs.)	139
Maximum Auger Diameter	24"
Hydraulic Flow	6 - 15 GPM
Maximum Hydraulic Pressure	3500 PSI
Maximum Hydraulic Back Pressure	1500 PSI
Gearbox Ratio	3.86:1

<i>Vehicle auxiliary flow (GPM)</i>					
6	8	10	12	14	15
36	48	60	73	85	91
<i>Auger bit speed (RPM)</i>					

<i>Vehicle auxiliary pressure (PSI)</i>			
2000	2500	3000	3500
1014	1267	1520	1774
<i>Drive unit torque (ft.-lbs.)</i>			

MODEL EP1020 \$2,390.00

Part No.	180406
Approx. Ship Weight (lbs.)	139
Maximum Auger Diameter	30"
Hydraulic Flow	10 - 20 GPM
Maximum Hydraulic Pressure	3500 PSI
Maximum Hydraulic Back Pressure	1500 PSI
Gearbox Ratio	3.86:1

<i>Vehicle auxiliary flow (GPM)</i>					
10	12	14	16	18	20
48	58	68	77	87	97
<i>Auger bit speed (RPM)</i>					

<i>Vehicle auxiliary pressure (PSI)</i>			
2000	2500	3000	3500
1270	1587	1904	2222
<i>Drive unit torque (ft.-lbs.)</i>			

MODEL EP1530 \$2,490.00

Part No.	180407
Approx. Ship Weight (lbs.)	142
Maximum Auger Diameter	36"
Hydraulic Flow	15 - 30 GPM
Maximum Hydraulic Pressure	3500 PSI
Maximum Hydraulic Back Pressure	1500 PSI
Gearbox Ratio	3.86:1

<i>Vehicle auxiliary flow (GPM)</i>					
15	18	20	24	28	30
49	59	65	78	92	98
<i>Auger bit speed (RPM)</i>					

<i>Vehicle auxiliary pressure (PSI)</i>			
2000	2500	3000	3500
1874	2342	2811	3279
<i>Drive unit torque (ft.-lbs.)</i>			

MODEL EP2035 \$2,665.00

Part No.	180408
Approx. Ship Weight (lbs.)	150
Maximum Auger Diameter	36"
Hydraulic Flow	20 - 35 GPM
Maximum Hydraulic Pressure	3500 PSI
Maximum Hydraulic Back Pressure	1500 PSI
Gearbox Ratio	3.86:1

<i>Vehicle auxiliary flow (GPM)</i>					
20	22	26	30	32	35
48	53	63	73	78	85
<i>Auger bit speed (RPM)</i>					

<i>Vehicle auxiliary pressure (PSI)</i>			
2000	2500	3000	3500
2529	3161	3794	4426
<i>Drive unit torque (ft.-lbs.)</i>			

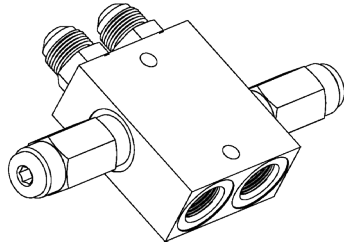
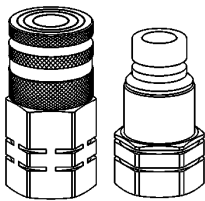
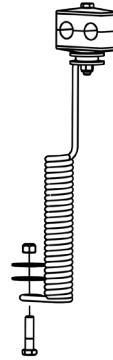
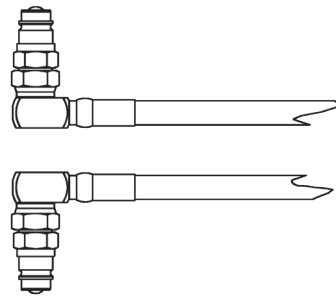
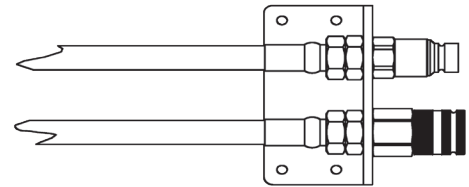

HOSES & HYDRAULIC ACCESSORIES

 Cross Port
Relief Valve

 Hose Holder
Spring Kit

 1/2" flush-face couplers
(ISO 16028)

 Front-End Loader
Hose Kit

PN	DESCRIPTION	WT.	PRICE
196035	Cross Port Relief Valve Required for pressures exceeding 3500 PSI.	7	\$460.00
190172	1/2" Hose Holder Spring Kit Allows adjustment of hose routing to reduce pinching and tugging.	2	\$57.00
196027	1/2" Hose Kit, 108" with Couplers & Abrasion Sleeves Includes 1/2" flush-face couplers (ISO 16028).	12	\$292.00
196025	1/2" Hose Kit, 108" with Abrasion Sleeves Includes fittings. Does not include quick couplers.	9	\$194.00
206032	1/2" Backhoe, Excavator, & Mini-Skid-Steer Hose Kit, 66" with Couplers & Abrasion Sleeves Includes 1/2" flush-face couplers (ISO 16028).	7	\$207.00
206031	1/2" Backhoe, Excavator, & Mini-Skid-Steer Hose Kit, 66" with Abrasion Sleeves Includes fittings. Does not include quick couplers.	7	\$117.00
196056	Front-End Loader Hose Kit 1/2" hoses, 25' long, with 1/2" flush-face couplers (ISO 16028) on one end to connect to 196027 Hose Kit above (sold separately), and ISO 7241 Series A couplers (compatible with ISO 5675 Pioneer couplers) on the opposite end to connect to tractor rear remotes. Includes bolt-on/weld-on mounting bracket.	27	\$482.00

MOUNTS

SKID-STEER QUICK ATTACH - CENTER & OFFSET

Mounting Kit attaches the drive unit to skid-steer quick attach with standard 2-pin system and SAE quick couplers. Two mounting positions available allow use with front-end loaders and skid-steers, and two cradle positions for transporting at 15° or 30° angles. **Includes** knuckle, cradle, hose holder spring kit, and hardware.

PN	WT.	PRICE
180415	156	\$605.00
*180415CSE	156	\$655.00

* Fits Case Models 1840

PN 180415

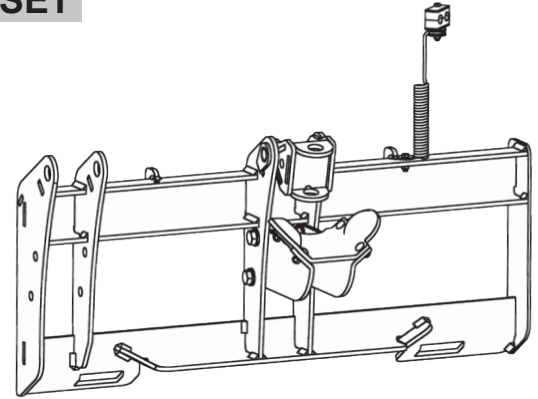

FRONT-END LOADER QUICK ATTACH - OFFSET

Mounting Kit attaches the drive unit to front-end loader quick attach systems. Two cradle positions for transporting at 15° or 30° angles. **Includes** knuckle, cradle, hose holder spring kit, and hardware.

PN	DESCRIPTION	WT.	PRICE
190052	Euro/Global	108	\$640.00
190053	John Deere 200-500	194	\$875.00

PN 190052

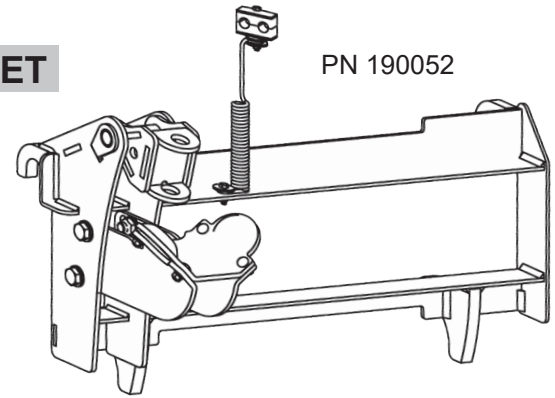

PN 190053

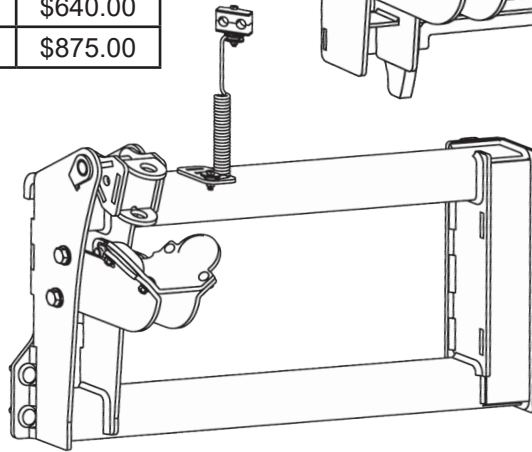

MINI-SKID-STEER QUICK ATTACH - CENTER

Mounting Kit attaches the drive unit to mini-skid-steer quick attach systems. Most vehicles with 72" or greater hinge pin height may use standard 4' length augers. Hinge pin heights 71" or shorter require 3' length augers maximum. **Includes** knuckle, cradle, hose holder spring kit, and hardware.

PN	DESCRIPTION	WT.	PRICE
200185	Mini-Skid-Steer	70	\$435.00
200207	Bobcat MT	104	\$480.00

PN 200185

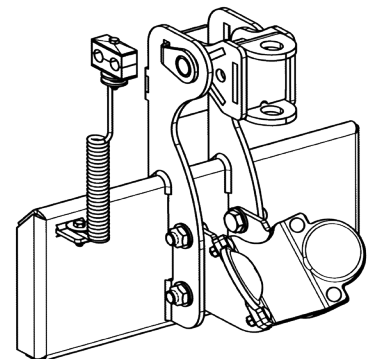

BACKHOE & EXCAVATOR QUICK ATTACH MOUNTING KITS

Quick Attach Mounting Kits include cradle.

PN	MAKES & MODELS	WT.	PRICE
180565	BOBCAT X-Change	90	\$715.00
230262	CASE 580 Super L series 1 & 2	138	\$1,130.00
180477	CAT 2008-2013 302D, 302.4D, 302.5, 302.5C, 302.7D	80	\$635.00
210150	CAT 303CR/CCR, 303.5E/E2, 304/305CR	95	\$855.00
180484	CAT 305.5E, 304C CR	90	\$855.00
190166	CAT 308, 309	117	\$1,025.00
180469	CAT 420D, 420E (pin grabber)	110	\$1,025.00
190160	JD 17D, 17G	74	\$635.00
180508	JD 26G, 27D, 30G, 35D, 35G (wedge)	96	\$635.00
180512	JD 50D, 50G, 60G (wedge), Hitachi ZX50	115	\$635.00
190034	JD 310, 410, fits all series except G	115	\$1,025.00
*180548	KUBOTA KX057, U55, U48	114	\$635.00
*190156	KUBOTA KX080	154	\$635.00
*180552	KUBOTA U25, U27	90	\$635.00
*180556	KUBOTA KX141-3, KX-018, U15, U17	109	\$635.00
*180539	KUBOTA KX161-3, U45	91	\$635.00
*180544	KUBOTA C39/45, KX033-4, KX71-3, KX040, KX91-3, KX121-3, U35	110	\$635.00
210178	SANY SY35U	110	\$855.00
180560	TAG Pin Grabber Style (quick coupler)	74	\$855.00
180572	TAG QC27 Style (quick coupler)	78	\$1,130.00
192008	TAG QC30 Style (quick coupler)	78	\$1,270.00
210161	TAKEUCHI TB250 (pin grabber)	101	\$1,270.00
180533	YANMAR ViO27, ViO35 (quick coupler)	85	\$855.00
180521	YANMAR ViO40, ViO45, ViO50, ViO55 (quick coupler)	85	\$855.00
240084	YANMAR ViO80, ViO100 (quick coupler)	115	\$1,025.00

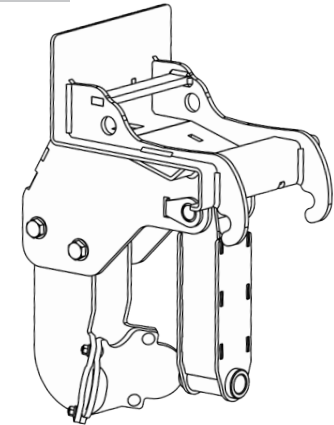

PN 180565

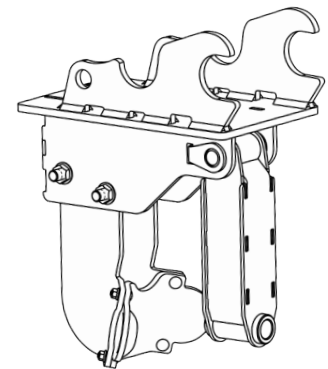

PN 180544

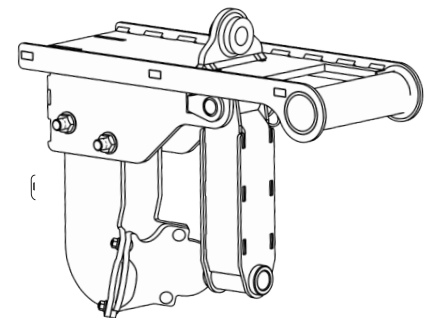

PN 180572

* USA models only. Will not fit gray market machines.

CALL FOR PRICE ON CUSTOM MOUNTS

BACKHOE & EXCAVATOR PIN-ON MOUNTING KITS

For dipperstick widths from 3-1/2" to 13". Mounting Kits do not include dipperstick pin.
Not for use on vehicles with stick breakout force greater than 28,250 lbs. or vehicle max operating weight greater than 55,000 lbs.

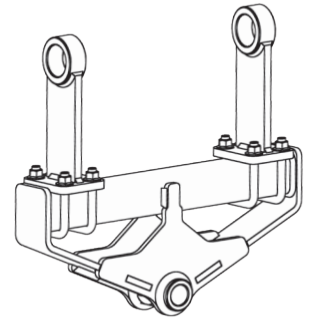

PN	BUCKET PIN DIA.	WT.	PRICE
180435	1" (25mm)	36	\$400.00
180436	30mm	36	\$400.00
180437	1-1/4"	36	\$400.00
180438	1-3/8" (35mm)	36	\$400.00
180439	1-1/2"	36	\$400.00
180440	40mm	38	\$400.00

PN	BUCKET PIN DIA.	WT.	PRICE
180441	1-5/8"	43	\$595.00
180442	1-3/4"	42	\$595.00
180443	45mm	45	\$595.00
180444	50mm	45	\$595.00
180445	2"	45	\$595.00
180446	55mm	41	\$595.00

UNIVERSAL & BOLT-ON MOUNTING KITS

UNIVERSAL MOUNTING KIT

Mounting Kit requires fabrication and welding for installation to machine. Weldable dimensions are 10" wide and 16" long. Two cradle positions for transporting at 15° or 30° angles.
Includes plate, knuckle, cradle, and hardware.

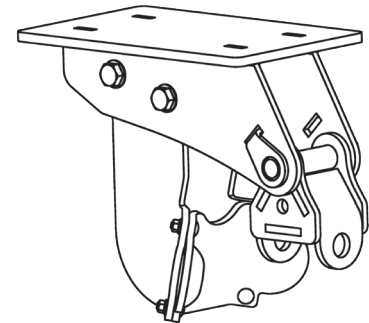

PN	WT.	PRICE
192015	65	\$435.00

BOLT-ON BUCKET KIT

Mounting Kit attaches the drive unit to a flat vertical surface.
Includes plate and knuckle assembly. Does not include bucket mounting hardware.

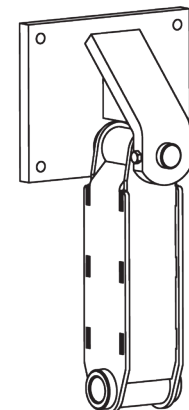

PN	WT.	PRICE
190203	41	\$375.00



AUGERS & ACCESSORIES

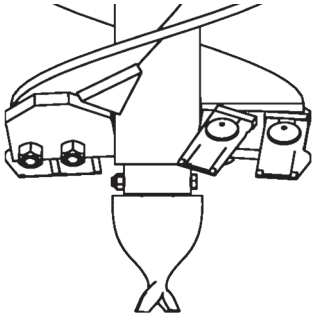

(Light-Duty) Light to Moderate Ground Conditions

- Fabricated Boring Head
- Hardened Bolt-on Teeth (Dirt)
 - » Gage Teeth in Outermost Positions
 - » Wisdom Teeth in Inner Positions
- Hardened Fishtail Point (Dirt)
- 5/16" Heavy-Duty Double Flighting on 8" Diameter & Larger;
5/16" Single Flighting on 6"; 3/8" Single Flighting on 4"

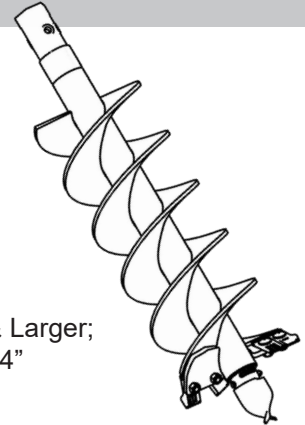

4' Length Augers - STANDARD

DIA.	PRICE	NO. OF TEETH	WT.	2" HEX PN	2-9/16" RD PN	2" RD PN
4"	\$324.00	0	42	10600	10601	10602
6"	\$350.00	2	46	10603	10604	10605
8"	\$500.00	2	78	10606	10607	10608
9"	\$519.00	3	85	10609	10610	10611
10"	\$570.00	3	98	10612	10613	10614
12"	\$589.00	4	115	10615	10616	10617
15"	\$817.00	5	135	10618	10619	10620
16"	\$842.00	5	146	10621	10622	10623
18"	\$953.00	6	170	10624	10625	10626
20"	\$1,179.00	6	182	10627	10628	10629
24"	\$1,224.00	8	211	10630	10631	10632
30"	\$1,522.00	9	272	10633	10634	10635
36"	\$1,918.00	11	365	10636	10637	10638

3' Length Augers

DIA.	PRICE	NO. OF TEETH	WT.	2" HEX PN	2-9/16" RD PN	2" RD PN
4"	\$317.00	0	42	10600-3	10601-3	10602-3
6"	\$333.00	2	42	10603-3	10604-3	10605-3
8"	\$468.00	2	57	10606-3	10607-3	10608-3
9"	\$484.00	3	62	10609-3	10610-3	10611-3
10"	\$514.00	3	69	10612-3	10613-3	10614-3
12"	\$538.00	4	78	10615-3	10616-3	10617-3
15"	\$712.00	5	87	10618-3	10619-3	10620-3
16"	\$757.00	5	93	10621-3	10622-3	10623-3
18"	\$794.00	6	106	10624-3	10625-3	10626-3
20"	\$922.00	6	134	10627-3	10628-3	10629-3
24"	\$1,090.00	8	153	10630-3	10631-3	10632-3
30"	\$1,348.00	9	208	10633-3	10634-3	10635-3
36"	\$1,671.00	11	275	10636-3	10637-3	10638-3



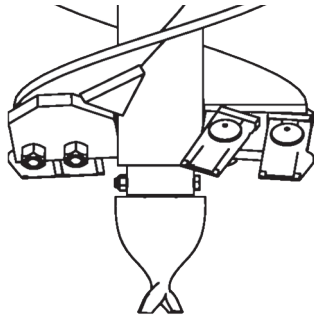

FABRICATED AUGERS (Light-Duty) Light to Moderate Ground Conditions

- Fabricated Boring Head
- Hardened Bolt-on Teeth (Dirt)
 - » Gage Teeth in Outermost Positions
 - » Wisdom Teeth in Inner Positions
- Hardened Fishtail Point (Dirt)
- 5/16" Heavy-Duty Double Flighting on 8" Diameter & Larger;
5/16" Single Flighting on 6"; 3/8" Single Flighting on 4"

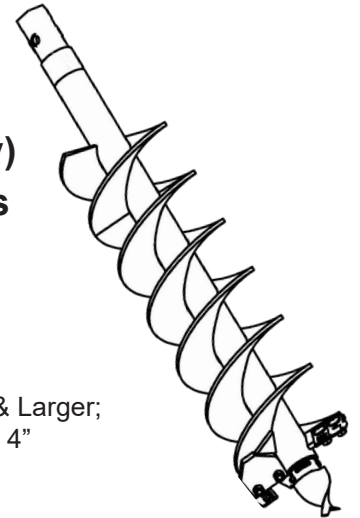

5' Length Augers

DIA.	PRICE	NO. OF TEETH	WT.	2" HEX PN	2-9/16" RD PN	2" RD PN
4"	\$393.00	0	51	10600-5	10601-5	10602-5
6"	\$468.00	2	51	10603-5	10604-5	10605-5
8"	\$628.00	2	101	10606-5	10607-5	10608-5
9"	\$636.00	3	111	10609-5	10610-5	10611-5
10"	\$727.00	3	126	10612-5	10613-5	10614-5
12"	\$734.00	4	145	10615-5	10616-5	10617-5
15"	\$999.00	5	164	10618-5	10619-5	10620-5
16"	\$1,143.00	5	177	10621-5	10622-5	10623-5
18"	\$1,247.00	6	207	10624-5	10625-5	10626-5
20"	\$1,378.00	6	254	10627-5	10628-5	10629-5
24"	\$1,475.00	8	268	10630-5	10631-5	10632-5
30"	\$2,164.00	9	445	10633-5	10634-5	10635-5
36"	\$2,347.00	11	501	10636-5	10637-5	10638-5

6' Length Augers

DIA.	PRICE	NO. OF TEETH	WT.	2" HEX PN	2-9/16" RD PN	2" RD PN
4"	\$440.00	0	60	10600-6	10601-6	10602-6
6"	\$606.00	2	60	10603-6	10604-6	10605-6
8"	\$734.00	2	128	10606-6	10607-6	10608-6
9"	\$757.00	3	141	10609-6	10610-6	10611-6
10"	\$847.00	3	160	10612-6	10613-6	10614-6
12"	\$922.00	4	186	10615-6	10616-6	10617-6
15"	\$1,218.00	5	193	10618-6	10619-6	10620-6
16"	\$1,384.00	5	208	10621-6	10622-6	10623-6
18"	\$1,499.00	6	244	10624-6	10625-6	10626-6
20"	\$1,718.00	6	296	10627-6	10628-6	10629-6
24"	\$1,991.00	8	325	10630-6	10631-6	10632-6
30"	\$2,724.00	9	527	10633-6	10634-6	10635-6
36"	\$3,045.00	11	615	10636-6	10637-6	10638-6



AUGERS & ACCESSORIES

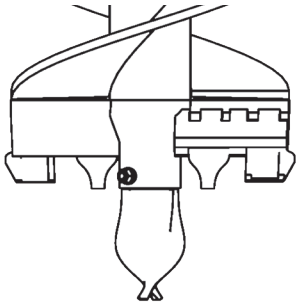

CAST HEAD AUGERS (Heavy-Duty)

Difficult Ground Conditions

- Cast Steel Boring Head
- Hardened Drive-in Teeth (Dirt)
 - » Gage Teeth in Outermost Positions
 - » Chisel Teeth in Inner Positions
- Hardened Fishtail Point (Dirt)
- 5/16" Heavy-Duty Double Flighting on 8" Diameter & Larger; Single Flighting on 6"

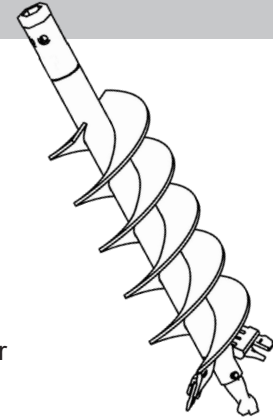

4' Length Augers - STANDARD

DIA.	PRICE	NO. OF TEETH	WT.	2" HEX PN	2-9/16" RD PN	2" RD PN
6"	\$526.00	2	48	10657	10658	10659
8"	\$758.00	4	83	10660	10661	10662
9"	\$817.00	4	89	10663	10664	10665
10"	\$842.00	4	102	10666	10667	10668
12"	\$867.00	4	117	10669	10670	10671
15"	\$1,095.00	6	139	10672	10673	10674
16"	\$1,179.00	6	148	10675	10676	10677
18"	\$1,289.00	6	168	10678	10679	10680
20"	\$1,802.00	6	231	10681	10682	10683
24"	\$1,802.00	8	210	10684	10685	10686
30"	\$2,372.00	10	280	10687	10688	10689
36"	\$2,696.00	12	376	10690	10691	10692
42"	\$3,725.00	16	460	10693	10694	---
48"	\$4,316.00	18	550	10696	10697	---

3' Length Augers

DIA.	PRICE	NO. OF TEETH	WT.	2" HEX PN	2-9/16" RD PN	2" RD PN
6"	\$507.00	2	40	10657-3	10658-3	10659-3
8"	\$689.00	4	67	10660-3	10661-3	10662-3
9"	\$734.00	4	70	10663-3	10664-3	10665-3
10"	\$740.00	4	74	10666-3	10667-3	10668-3
12"	\$778.00	4	81	10669-3	10670-3	10671-3
15"	\$985.00	6	90	10672-3	10673-3	10674-3
16"	\$1,036.00	6	96	10675-3	10676-3	10677-3
18"	\$1,167.00	6	108	10678-3	10679-3	10680-3
20"	\$1,567.00	6	122	10681-3	10682-3	10683-3
24"	\$1,588.00	8	154	10684-3	10685-3	10686-3
30"	\$2,075.00	10	209	10687-3	10688-3	10689-3
36"	\$2,200.00	12	276	10690-3	10691-3	10692-3
42"	\$3,417.00	16	416	10693-3	10694-3	---
48"	\$3,909.00	18	306	10696-3	10697-3	---



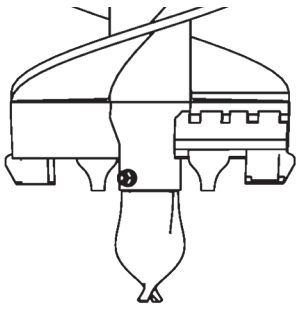

CAST HEAD AUGERS (Heavy-Duty)

Difficult Ground Conditions

- Cast Steel Boring Head
- Hardened Drive-in Teeth (Dirt)
 - » Gage Teeth in Outermost Positions
 - » Chisel Teeth in Inner Positions
- Hardened Fishtail Point (Dirt)
- 5/16" Heavy-Duty Double Flighting on 8" Diameter & Larger; Single Flighting on 6"

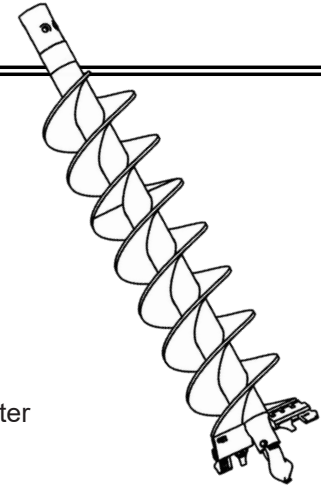

5' Length Augers

DIA.	PRICE	NO. OF TEETH	WT.	2" HEX PN	2-9/16" RD PN	2" RD PN
6"	\$658.00	2	62	10657-5	10658-5	10659-5
8"	\$847.00	4	121	10660-5	10661-5	10662-5
9"	\$894.00	4	125	10663-5	10664-5	10665-5
10"	\$1,014.00	4	143	10666-5	10667-5	10668-5
12"	\$1,036.00	4	158	10669-5	10670-5	10671-5
15"	\$1,196.00	6	167	10672-5	10673-5	10674-5
16"	\$1,226.00	6	180	10675-5	10676-5	10677-5
18"	\$1,362.00	6	209	10678-5	10679-5	10680-5
20"	\$1,870.00	6	241	10681-5	10682-5	10683-5
24"	\$2,007.00	8	269	10684-5	10685-5	10686-5
30"	\$2,604.00	10	374	10687-5	10688-5	10689-5
36"	\$2,814.00	12	502	10690-5	10691-5	10692-5
42"	\$4,515.00	16	611	10693-5	10694-5	---
48"	\$5,509.00	18	765	10696-5	10697-5	---

6' Length Augers

DIA.	PRICE	NO. OF TEETH	WT.	2" HEX PN	2-9/16" RD PN	2" RD PN
6"	\$718.00	2	70	10657-6	10658-6	10659-6
8"	\$946.00	4	138	10660-6	10661-6	10662-6
9"	\$992.00	4	140	10663-6	10664-6	10665-6
10"	\$1,059.00	4	146	10666-6	10667-6	10668-6
12"	\$1,083.00	4	189	10669-6	10670-6	10671-6
15"	\$1,317.00	6	196	10672-6	10673-6	10674-6
16"	\$1,553.00	6	212	10675-6	10676-6	10677-6
18"	\$1,574.00	6	246	10678-6	10679-6	10680-6
20"	\$2,081.00	6	284	10681-6	10682-6	10683-6
24"	\$2,247.00	8	327	10684-6	10685-6	10686-6
30"	\$3,058.00	10	529	10687-6	10688-6	10689-6
36"	\$3,285.00	12	616	10690-6	10691-6	10692-6
42"	\$5,715.00	16	791	10693-6	10694-6	---
48"	\$7,586.00	18	994	10696-6	10697-6	---





BULLET ROCK AUGERS

Rock, Concrete, Asphalt,
and Frozen Ground

4' Length Augers

DIA.	PRICE	NO. OF TEETH	PILOT	WT.	2" HEX PN	2-9/16" PN
4.5"	\$1,190.00	4	---	73	200152	200153
6"	\$1,781.00	6	6-tooth	66	200155	200156
8"	\$2,016.00	8	4-tooth	94	200158	200159
9"	\$2,046.00	10	4-tooth	103	200161	200162
10"	\$2,099.00	10	4-tooth	113	200164	200165
12"	\$2,303.00	12	4-tooth	135	200167	200168
15"	\$2,645.00	14	4-tooth	171	200170	200171
18"	\$2,900.00	16	4-tooth	208	200173	200174
24"	\$3,456.00	20	4-tooth	291	200176	200177
30"	\$3,819.00	24	4-tooth	340	200179	200180
36"	\$4,327.00	28	4-tooth	395	200182	200183

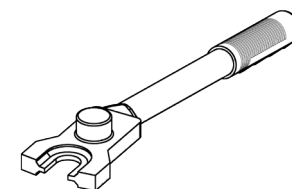
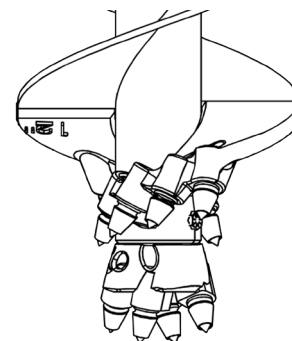

Bullet Tooth Hammer & Puller
PN 10766 \$309.00

Bolt-on Pilot Style Parts

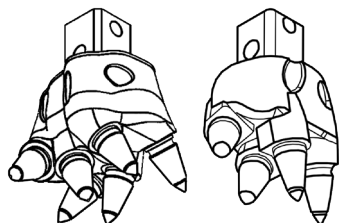

Bullet Rock Pilot (Bolt-on)
6-tooth PN 200251 \$706.00
4-tooth PN 200192 \$524.00

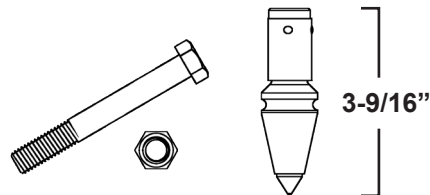

Bullet Tooth & Pilot Hardware
Tooth PN 200281 \$28.00
Pilot Nut PN 7733 \$0.32
Pilot Bolt PN 10123 \$1.41

Screw-in Pilot Style Parts



Bullet Rock Pilot (Screw-in)
PN 10758 \$519.00

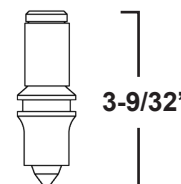

Bullet Tooth
PN 10759 \$28.00

TREE AUGERS

Tree and Shrub Planting

4' Length Augers

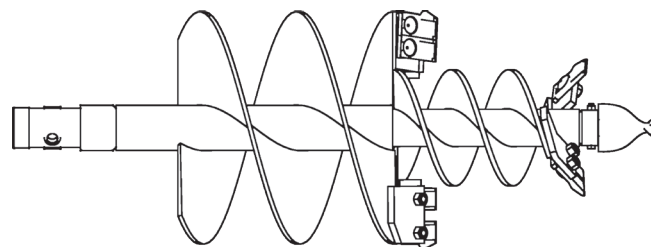

DIA.	PRICE	NO. OF TEETH	WT.	2" HEX PN	2-9/1 RD PN	2" RD PN
18"-9"	\$895.00	7	130	10639	10640	10641
24"-12"	\$1,181.00	10	186	10642	10643	10644
30"-15"	\$1,471.00	11	228	10645	10646	10647
36"-18"	\$1,768.00	13	304	10648	10649	10650

- Fabricated Boring Head
- Hardened Bolt-on Teeth (Dirt)
 - » Gage Teeth in Outermost Positions
 - » Wisdom Teeth in Inner Positions
- Hardened Fishtail Point (Dirt)
- 5/16" Heavy-Duty Double Flighting





AUGER POINTS, TEETH, HARDWARE

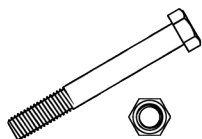

Point Hardware (Fab, Cast, Wobble, Tree)		
Nut	PN 10412	\$0.37
Bolt	PN 10413	\$0.80
Bolt for 4"	PN 10416	\$0.33

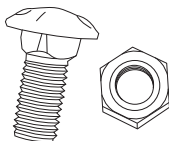

Tooth Hardware (for Fab Augers)		
Bolt	PN 10410	\$1.87
Nut	PN 10411	\$0.75

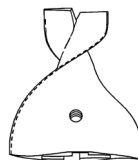

4" Auger Point	
PN 10333D	\$70.00
PN 10333HF	\$122.00
PN 10333C	\$225.00



Fishtail Point	
PN 10331D	\$38.00
PN 10331HF	\$81.00
PN 10331C	\$200.00

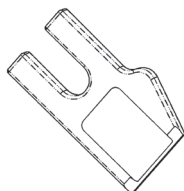

Gage Tooth	
PN 10340D	\$6.30
PN 10340HF	\$13.35

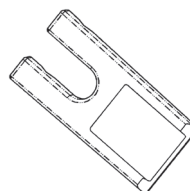

Wisdom Tooth	
PN 10337D	\$6.30
PN 10337HF	\$13.35
PN 10337C	\$37.00

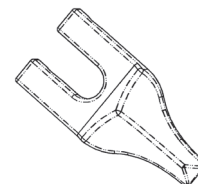

Chisel Tooth	
PN 10342D	\$6.30
PN 10342HF	\$14.75
PN 10342C	\$28.00

Dirt = D
Hardfaced = HF
Carbide = C

ADAPTERS

Connect Danuser drive units to other augers or Danuser augers to other drive units.

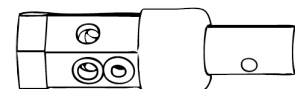

DRIVE UNIT	AUGER	PRICE	WT.	PN
2" Hex	2-9/16" Rd.	\$302.00	18	10921
2" Hex	2" Rd.	\$278.00	18	10922
2-9/16" Rd.	2" Hex	\$182.00	14	10923
2-9/16" Rd.	2" Rd.	\$193.00	12	10924
2" Rd.	2" Hex	\$165.00	12	10925
2" Rd.	2-9/16" Rd.	\$184.00	11	10926

DRIVE UNIT	AUGER	PRICE	WT.	PN
2" Hex	2-9/16" Rd.	\$207.00	18	*20211
2-9/16" Rd.	2-9/16" Rd.	\$207.00	15	*20212
2" Hex	2" Rd.	\$207.00	18	*20214
2-9/16" Rd.	2" Rd.	\$207.00	12	*20215

*Allows attachment of augers with 1/2" diameter bolt.

2" ROCK DRILL

T-Post & Pilot Holes

3' Length Augers

For pilot holes or setting posts up to 2" O.D. in solid rock

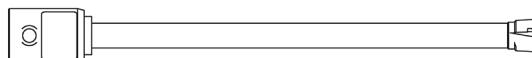

DIA.	PRICE	WT.	2" HEX PN	2-9/1 RD PN	2" RD PN
2"	\$454.00	30	10739	10743	10744

2" Rock Drill Pilot
PN 10745

List Price: \$143.00

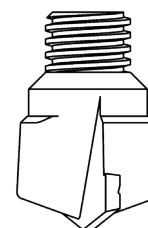



WOBBLE AUGERS

Wobble Augers create a dirtless hole that is ideal for setting posts in concrete, sand, or gravel. 4" auger can be used as a pilot hole for post drivers.

- Pushes through dirt, sand, clay, asphalt, compacted and embedded rock, and frozen ground
- Rotates off-center to “wobble” a compacted hole
- Ideal for setting posts in concrete
- Won't leave excess loose material to clean up
- Eliminates extra time on the job and reduces labor costs
- Spiral & Checkered Hardfacing and hardened Fishtail Point (Dirt)
- Not for use on 3-point hitch mounted diggers.

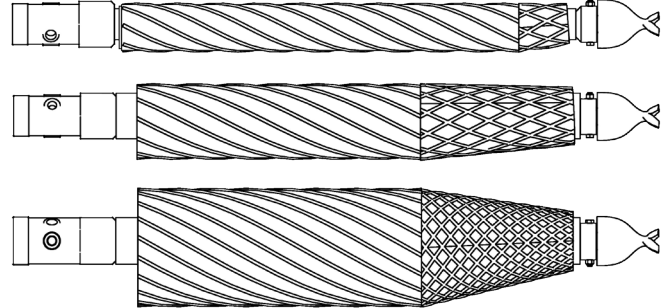

4' Length Wobble Augers

DIA.	PRICE	WT.	2" HEX PN	2-9/16" RD PN	2" RD PN
4"	\$456.00	58	20600	20601	20602
6"	\$576.00	86	20603	20604	20605
9"	\$881.00	122	20606	20607	20608

Points

PN	DESCRIPTION	PRICE
10331D	Dirt	\$38.00
10331HF	Hardfaced	\$81.00

NOTE: The 9" Wobble Auger should be used on a machine with an Operating Load or Rated Operating Capacity of 2,250 lb. or greater, utilizing an auger drive with 2,000 ft.-lb. of torque or greater.

STUMP AUGERS

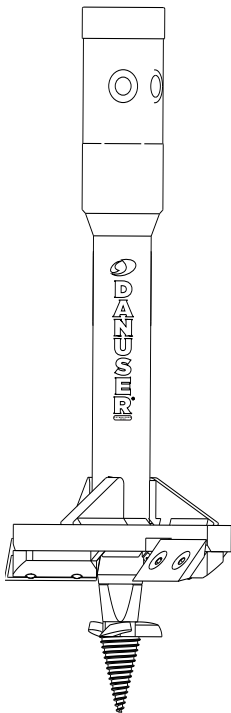

The stump auger planes away stumps without requiring large, specialized equipment. A threaded pilot digs into the stump and large cutting blades then shave the stump away. The large cutting blades can be reversed and sharpened for extended cutting life.

- 2" hex collar
- Hardened steel cutting blades
 - » Reversible/indexable for more cutting per blade
- Hardened steel pilot with cutting blades
- 10" and 16" diameter options
 - » 10" for use with 1,700 ft.-lb. of torque and higher drive units
 - » 16" for use with 3,000 ft.-lb. of torque and higher drive units
- Overall length
 - » 27" for both sizes

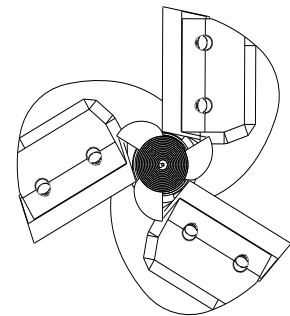

PN	DESCRIPTION	WT.	PRICE
190127	Stump Auger - 10" for use on EP1020 and larger	50	\$900.00
200199	Stump Auger - 16" for use on EP1530 and larger	70	\$1,030.00





VARIABLE LENGTH EXTENSIONS

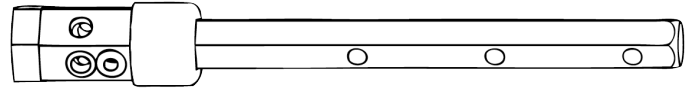

Variable length auger extensions store inside the center columns of some augers. For Bullet Rock Augers, minimum diameter is 6". For Fab, Cast, and Tree Augers, minimum diameter is 10".

Extension increments are every 6" on 12" - 24" auger extensions and every 12" on 48" - 72" auger extensions.

2" Hex

LENGTH	PRICE	WT.	PN
24"	\$303.00	32	10900
48"	\$418.00	56	10901
72"	\$544.00	84	10902

2-9/16" Round

LENGTH	PRICE	WT.	PN
12"	\$223.00	22	10903
24"	\$311.00	38	10904
48"	\$432.00	73	10905
72"	\$573.00	84	10906

2" Round

LENGTH	PRICE	WT.	PN
24"	\$223.00	24	10907
48"	\$311.00	46	10908
72"	\$430.00	66	10909

FIXED LENGTH EXTENSIONS

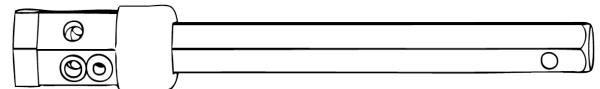

Fixed length auger extensions extend the auger's digging depth by the length of the extension.

2" Hex

LENGTH	PRICE	WT.	PN
12"	\$219.00	20	10910
24"	\$267.00	32	10911
48"	\$375.00	56	10912
72"	\$491.00	84	10913

2-9/16" Round

LENGTH	PRICE	WT.	PN
12"	\$219.00	38	10914
24"	\$267.00	40	10915
48"	\$375.00	76	10916
72"	\$519.00	110	10917

2" Round

LENGTH	PRICE	WT.	PN
24"	\$206.00	25	10918
48"	\$286.00	47	10919
72"	\$393.00	68	10920

REPAIR PARTS & SAFETY SIGNS

To find repair parts and safety signs, see Danuser's online Parts Catalog at parts.danuser.com.

The Parts Catalog includes all current attachment parts and decals in a user-friendly, accessible, and portable format.

Be sure to have model and serial number at hand to find the correct items.

