

OPERATOR'S MANUAL

BOX BLADES CBS SERIES



Tuffline®

TO THE DEALER:

Assembly and proper installation of this product is the responsibility of the Monroe Tufline dealer. Read manual instructions and safety rules. Make sure all items on the Dealer's Pre-Delivery and Delivery Check Lists in the Owner's/Operator's Manual are completed before releasing equipment to the owner. The dealer must complete the Warranty Registration located on the Frontier website.

TO THE OWNER:

Read this manual before operating your Monroe Tufline equipment. The information presented will prepare you to do a better and safer job. Keep this manual handy for ready reference. Require all operators to read this manual carefully and become acquainted with all the adjustment and operating procedures before attempting to operate. Replacement manuals can be obtained from your selling dealer.

The equipment you have purchased has been carefully engineered and manufactured to provide dependable and satisfactory use. Like all mechanical products, it will require cleaning and upkeep. Lubricate the unit as specified. Observe all safety information in this manual and safety decals on the equipment.

For service, your authorized Monroe Tufline dealer has trained mechanics, genuine Monroe Tufline service parts, and the necessary tools and equipment to handle all your needs.

Use only genuine Frontier service parts. Substitute parts will void the warranty and may not meet standards required for safe and satisfactory operation. Record the model number and serial number of your equipment in the spaces provided:

Model: _____ Date of Purchase: _____

Serial Number: (see Safety Decal section for location) _____

Provide this information to your dealer to obtain correct repair parts.

Throughout this manual, the term **IMPORTANT** is used to indicate that failure to observe can cause damage to equipment. The terms **CAUTION**, **WARNING** and **DANGER** are used in conjunction with the Safety-Alert Symbol, (a triangle with an exclamation mark), to indicate the degree of hazard for items of personal safety.



This Safety-Alert Symbol indicates a hazard and means **ATTENTION! BECOME ALERT! YOUR SAFETY IS INVOLVED!**

DANGER

Indicates an imminently hazardous situation that, if not avoided, will result in death or serious injury.

WARNING

Indicates a potentially hazardous situation that, if not avoided, could result in death or serious injury, and includes hazards that are exposed when guards are removed.

CAUTION

Indicates a potentially hazardous situation that, if not avoided, may result in minor or moderate injury.

IMPORTANT NOTE

Indicates that failure to observe can cause damage to equipment.

Indicates helpful information.

TABLE OF CONTENTS

INTRODUCTION	ii
SPECIFICATIONS / GENERAL INFORMATION	1
SAFETY DECALS	2
SAFETY RULES	3 - 5
DEALER INSTRUCTIONS	6
OPERATION	7 - 9
OWNER SERVICE	10 - 11
PARTS CATALOG	12
BOLT SIZE AND BOLT TORQUE CHART	13
NOTES	14



SPECIFICATIONS

	CBS-84	CBS-96	CBS-120
3-Point Hitch	Category I and II Quick Hitch (iMatch Compatible)	Category I and II Quick Hitch (iMatch Compatible)	Category I and II Quick Hitch (iMatch Compatible)
Working Width	84"	96"	120"
Tractor HP (MAX)	35-80 HP	45-100 HP	55-120 HP
Approximate Operating Weight	675 lbs.	765 lbs.	950 lbs.
Beam Type	Tubular 4" sq. Beam	Tubular 4" sq Beam	Tubular 4" sq Beam
Capacity	44 cu. ft.	50 cu. ft.	60 cu. ft.
Cutting Edges	1/2" x 6' Reversible	1/2" x 6' Reversible	1/2" x 6' Reversible
End Plate Thickness	3/8"	3/8"	3/8"
Moldboard Thickness	1/4"	1/4"	1/4"
Assembly Time	15 min.	15 min.	15 min.

GENERAL INFORMATION

The purpose of this manual is to assist you in operating and maintaining your Box Blade. Read it carefully. It furnishes information and instructions that will help you achieve years of dependable performance.

These instructions have been compiled from field experience and engineering data. Some information may be general in nature, due to unknown and varying operating conditions. However, through experience and these instructions, you should be able to develop procedures suitable to your particular situation.

The illustrations and data used in this manual were current at the time of printing. However, due to possible inline production changes, your machine may vary slightly in detail. We reserve the right to redesign and change the machines as may be necessary without notification.

Throughout this manual, references are made to right and left direction. These are determined by standing behind the tractor facing the direction of forward travel.

SAFETY & INSTRUCTIONAL DECALS

ATTENTION! BECOME ALERT! YOUR SAFETY IS INVOLVED!

FAILURE TO FOLLOW THESE INSTRUCTIONS COULD RESULT IN SERIOUS INJURY OR DEATH

Replace Decals Immediately If Damaged!

D- Serial Number Plate



Check that all safety decals are installed and in good condition. Replace if decals are worn or damaged. Replacement Part numbers are listed here.

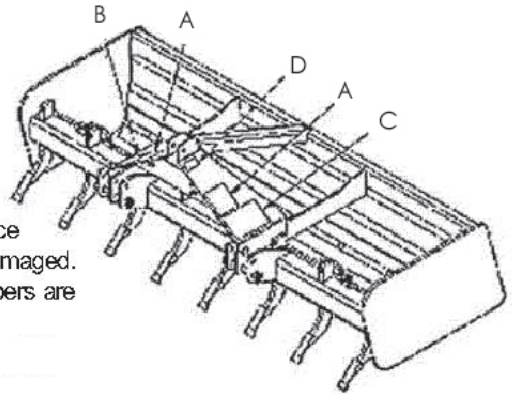

WARNING

TO AVOID SERIOUS INJURY OR DEATH:

- Read Operator's Manual before operating, servicing or repairing equipment. Follow all safety rules and instructions. (Manuals are available from your selling dealer.)
- Never allow riders.
- Keep bystanders away from equipment during operation.
- Operate from tractor seat only.
- Keep all shields in place and in good condition.
- Lower equipment to ground, stop engine, remove key and set brake before dismounting tractor.
- Never allow children or untrained persons to operate equipment.
- Do not transport towed or semi-mounted units over 20 MPH.

FAILURE TO FOLLOW THESE INSTRUCTIONS CAN RESULT IN INJURY OR DEATH.

WARNING

CRUSHING AND PINCHING HAZARD

- Be extremely careful handling various parts of the machine. They are heavy and hands, fingers, feet, and other body parts could be crushed or pinched between tractor and implement.
- Operate tractor controls from tractor seat only.
- Do not stand between tractor and implement when tractor is in gear.
- Make sure parking brake is engaged before going between tractor and implement.
- Stand clear of machine while in operation or when it is being raised or lowered.

FAILURE TO FOLLOW THESE INSTRUCTIONS COULD RESULT IN SERIOUS INJURY OR DEATH.

WARNING

FALLING OFF CAN RESULT IN BEING RUN OVER.

- Tractor must be equipped with ROPS (or ROPS CAB) and seat belt. Keep foldable ROPS systems in "locked up" position at all times.
- Buckle Up! Keep seat belt securely fastened.
- Allow no riders.

RAISED IMPLEMENT CAN DROP AND CRUSH.

- Never go underneath raised implement which can drop from equipment or tractor 3-point hitch hydraulic leak down, hydraulic system failures, movement of control levers or mechanical linkage failures.
- Service work does not require going underneath implement. Read manual instructions.

FALLING OFF OR GOING UNDERNEATH IMPLEMENT CAN RESULT IN SERIOUS INJURY OR DEATH.



SAFETY RULES



ATTENTION! BECOME ALERT! YOUR SAFETY IS INVOLVED!

Safety is a primary concern in the design and manufacture of our products. Unfortunately, our efforts to provide safe equipment can be wiped out by an operator's single careless act.

In addition to the design and configuration of equipment, hazard control and accident prevention are dependent upon the awareness, concern, judgement, and proper training of personnel involved in the operation, transport, maintenance and storage of equipment.

It has been said "The best safety device is an informed, careful operator." We ask you to be that kind of operator.

TRAINING

- Safety instructions are important! Read all attachment and power unit manuals; follow all safety rules and safety decal information. (Replacement manuals are available from selling dealer.) Failure to follow instructions or safety rules can result in serious injury or death.
- If you do not understand any part of this manual and need assistance, see your dealer.
- Operators must be instructed in and be capable of the safe operation of the equipment, its attachments, and all controls. Do not allow anyone to operate this equipment without proper instructions.
- Never allow children or untrained persons to operate equipment.
- Train all new personnel and review instruction's frequently with existing workers. A person who has not read and understood all operating and safety instructions is not qualified to operate the machine. An untrained operator exposes himself and bystanders to possible serious injury or death.

PREPARATION

- Always wear relatively tight and belted clothing to

avoid getting caught in moving parts. Wear sturdy, rough-soled work shoes and protective equipment for eyes, hair, hands, hearing, and head; and respirator or filter mask where appropriate.

- Make sure attachment is properly secured, adjusted, and in good operating condition.
- Power unit must be equipped with ROPS or ROPS cab and seat belt. Keep seat belt securely fastened. Falling off power unit can result in death from being run over or crushed. Keep foldable ROPS system in "locked up" position at all times.
- A minimum 20% of tractor and equipment weight must be on the tractor front wheels when attachments are in transport position. Without this weight, tractor could tip over, causing personal injury or death. The weight may be attained with a loader, front wheel weights, ballast in tires or front tractor weights. Weigh the tractor and equipment. Do not estimate.

TRANSPORTATION

- Always comply with all state and local laws governing highway safety and lighting and marking requirements.
- Never allow riders on power unit or attachment.
- Do not operate or transport on steep slopes.
- Use extreme care and reduce ground speed on slopes and rough terrain.
- Do not operate or transport equipment while under the influence of alcohol or drugs. Consult your doctor about operating this machine while taking prescription medications.

OPERATION

- Never go underneath equipment (lowered to the ground or raised) unless it is properly
- Safety Rules continued on next page.*



SAFETY RULES



ATTENTION! BECOME ALERT! YOUR SAFETY IS INVOLVED!

Safety Rules continued from previous page.

OPERATION (cont'd)

blocked and secured. Never place any part of the body underneath equipment or between moveable parts even when the engine has been turned off. Hydraulic system leak down, hydraulic system failures, mechanical failures, or movement of control levers can cause equipment to drop or rotate unexpectedly and cause severe injury or death.

- Always comply with all state and local laws governing highway safety and lighting and marking requirements.
- Operate only in daylight or good artificial light.
- Keep bystanders away from equipment.
- Keep hands, feet, hair, and clothing away from equipment while engine is running. Stay clear of all moving parts.
- Power unit must be equipped with ROPS or ROPS cab and seat belt. Keep seat belt securely fastened. Falling off power unit can result in death from being run over or crushed. Keep foldable ROPS system in “locked up” position at all times.
- Never allow riders on power unit or attachment.
- Always sit in power unit seat when operating controls or starting engine. Securely fasten seat belt, place transmission in neutral, engage brake, and ensure all other controls are disengaged before starting power unit engine.
- Look down and to the rear and make sure area is clear before operating in reverse.
- Use extreme care when working close to fences, ditches, other obstructions, or on hillsides.

- Do not operate or transport on steep slopes.
- Do not stop, start, or change directions suddenly on slopes. Always operate down slopes; never across the face.
- Use extreme care and reduce ground speed on slopes and rough terrain.
- Keep alert and watch the front as well as the rear when operating.
- When making adjustments, be careful to keep hands and feet clear of sliding parts and possible pinch points.
- Stop power unit and equipment immediately upon striking an obstruction. Turn off engine, remove key, inspect, and repair any damage before resuming operation.
- Before leaving operator’s seat, lower lift arms and put attachment on the ground. Engage brake, stop engine, remove key, and remove seat belt.

MAINTENANCE

- Always wear relatively tight and belted clothing to avoid getting caught in moving parts. Wear sturdy, rough-soled work shoes and protective equipment for eyes, hair, hands, hearing, and head; and respirator or filter mask where appropriate.
- Never go underneath equipment (lowered to the ground or raised) unless it is properly blocked and secured. Never place any part of the body underneath equipment or between moveable parts even when the engine has been turned off. Hydraulic system leak down, hydraulic system failures, mechanical failures, or movement of control levers can cause equipment to drop or rotate unexpectedly and cause severe injury or death.



SAFETY RULES



ATTENTION! BECOME ALERT! YOUR SAFETY IS INVOLVED!

- When performing maintenance or repairs make sure the equipment is in the lowered position and both the mainframe and gangs are properly blocked and secured to prevent rolling.

Safety Rules continued on next page.

Safety Rules continued from previous page.

MAINTENANCE(cont'd)

Failure to do so can cause serious injury or death.

- Make sure attachment is properly secured, adjusted, and in good operating condition.
- Before leaving operator's seat, lower lift arms and put attachment on the ground. Engage brake, stop engine, remove key, and remove seat belt.
- Never perform service or maintenance with engine running.

- Keep all persons away from operator control area while performing adjustments, service, or maintenance.

- Tighten all bolts, nuts, and screws to torque chart specifications. Check that all cotter pins are installed securely to ensure equipment is in a safe condition before putting unit into service.

STORAGE

- Block equipment securely for storage.
- Keep children and bystanders away from storage area.

DEALER INSTRUCTIONS

Pre-Assembly

Dealer Checklist

(Dealer's Responsibility)

Inspect the equipment thoroughly after assembly to be certain it is set up properly before delivering it to the customer. The following check list is a reminder of points to inspect.

Check off each item if it is found satisfactory or after proper adjustment is made.

____ Check that all safety decals are installed and in good condition. Replace if damaged.

____ Check all bolts to be sure they are tight.

____ Check that all cotter pins and safety pins are properly installed. prior to delivery to customer.

____ Show customer the safe, proper procedures to be used when mounting, dismounting, and storing equipment.

____ For mounted units, add wheel weights, ballast in front tires, and/or front tractor weight to enhance front end stability. A minimum 20% of tractor and equipment gross weight must be on front tractor wheels. When adding weight to attain 20% of tractor and equipment weight on front tractor wheels, you must not exceed the ROPS weight certification. Weigh the tractor and equipment. Do not estimate!

____ Show customer how to make adjustments.

____ Present Owner's/Operator's Manual and

request that customer and all operators read it before operating equipment. Point out the manual safety rules, explain their meanings and emphasize the increased safety hazards that exist when safety rules are not followed.

____ Point out the safety decals. Explain their meaning and the need to keep them in place and in good condition. Emphasize the increased safety hazards when instructions are not followed.

____ Explain to customer the potential crushing hazards of going underneath raised equipment. Instruct customer that service work does not require going underneath unit and never to do so.

____ Complete the Warranty Registration located on the Frontier website.

Operation

Safety is a primary concern in the design and manufacture of our products. Unfortunately, our efforts to provide safe equipment can be wiped out by an operator's single careless act.

In addition to the design and configuration of equipment, hazard control and accident prevention are dependent upon the awareness, concern, judgement, and proper training of personnel involved in the operation, transport, maintenance and storage of equipment.

It has been said "The best safety device is an informed, careful operator." We ask you to be that kind of operator.

The operator is responsible for the safe operation of this equipment. The operator must be properly trained. Operators should be familiar with the equipment, the tractor, and all safety practices before starting operation. Read the safety rules and safety decals on pages 2-6.

Owner should check and tighten all hardware after the first hour of operation. The break in stage of your new box blade can cause minimal loosening of hardware. Please see Bolt Torque Chart (page 16) for proper torque information.

WARNING

- Power unit must be equipped with ROPS or ROPS cab and seat belt. Keep seat belt securely fastened. Falling off power unit can result in death from being run over or crushed. Keep foldable ROPS systems in "locked up" position at all times.
- Never allow children or untrained persons to operate equipment.
- Keep bystanders away from equipment.

- NEVER GO UNDERNEATH EQUIPMENT. Never place any part of the body underneath equipment or between moveable parts even when the engine has been turned off. Hydraulic system leak down, hydraulic system failures, mechanical failures, or movement of control levers can cause equipment to drop or rotate unexpectedly and cause severe injury or death.

- Service work does not require going underneath.

- Read Manual for service instructions or have service performed by a qualified dealer.

- Stop tractor and implement immediately upon striking an obstruction. Turn off engine, remove key, inspect, and repair any damage before resuming operation.

- Always wear relatively tight and belted clothing to avoid entanglement in moving parts. Wear sturdy, rough-soled work shoes and protective equipment for eyes, hair, hands, hearing, and head.

Owner/Operator Pre-Operation Checklist

(Owner's/Operator's Responsibility)

___ Review and follow all safety rules and safety decal instructions on page 2 through page 6.

___ Check that equipment is properly and securely attached to tractor.

___ Check that all safety decals are installed and in good condition. Replace if damaged.

___ Check that all hardware is properly installed and secured.

___ Do not allow riders.

___ Make sure tractor ROPS or ROPS CAB and seat belt are in good condition. Keep seat belt securely fastened during operation.

Connecting Box Blade to the Tractor

The box blade is compatible with tractors equipped with Category 1 or Category 2, 3-point hitch systems that use side-swing type lower lift arms. The box blades will also fit tractors equipped with a Category 1 and 2 Quick Hitch system.

NOTE: When attaching box blade to any hitch other than a standard Category 1 hitch, bushings must be purchased separately.

Category 1 Standard (Figure 1)

1. Attach the tractor's lower lift arms to the box blade through the lower, inner set of holes.
2. Use the hitch pin supplied with your box blade and re-install the lynch pins.
3. Attach the tractor's top link to the box blade's mast using the heavy-duty top link pin and lynch pin supplied with the top link.

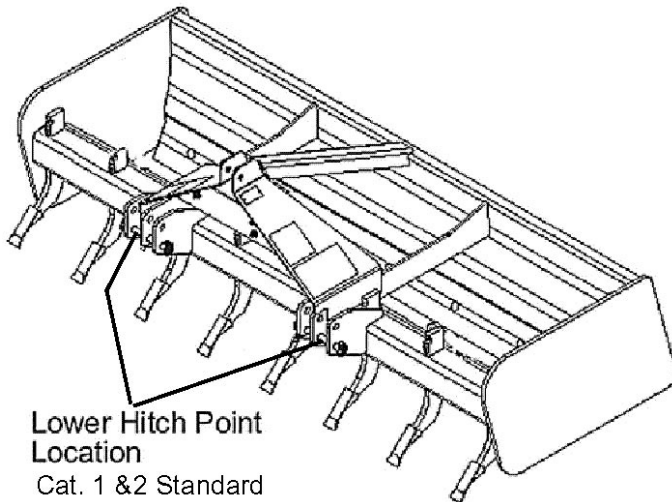

Figure 1. Category 1 and 2 Hitch Set-up

Category 2 Standard (Figure 1)

1. Use Category 1 Standard instructions except use lower, outer set of holes.

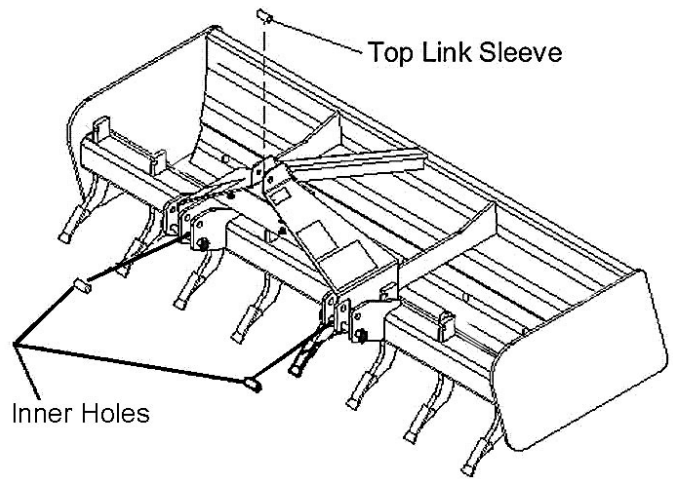

Figure 2. Category 1 Quick Hitch Set-up

Category 1 Quick Hitch (Figure 2)

1. Connect the tractor's Quick Hitch to the box blade through the upper, inner set of holes.
2. Slide lower sleeve (sold separately) over the mounting pin supplied with box blade. Re-install lynch pins.
3. Slide upper sleeve over the heavy-duty top link pin supplied with top link. Reinstall retaining pin.

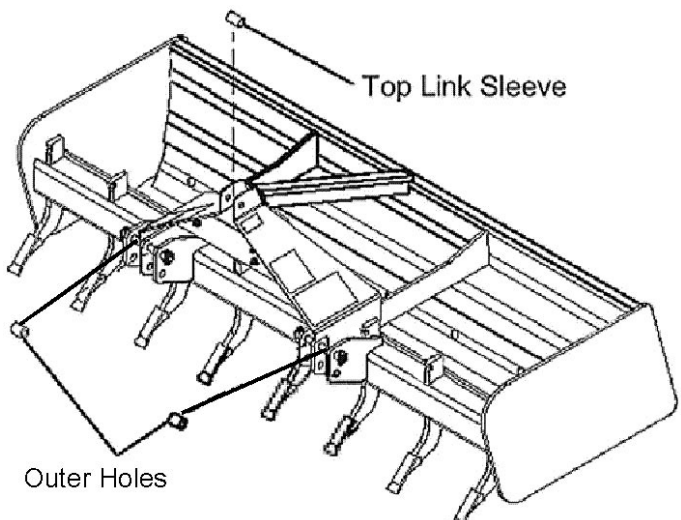

Figure 3. Category 2 Quick Hitch Set-up

Category 2 Quick Hitch (Figure 3)

1. Connect the tractor's Quick Hitch to the box blade through the upper, outer set of holes.
2. Slide upper sleeve over the heavy-duty top link pin supplied with top link. Reinstall retaining pin.

Operation(cont.)

ADJUSTING TOP LINK

The box blade is leveled by adjusting the length of the tractor's top link.

- Shortening the top link will deepen the scarifier tooth penetration.
- Lengthening the top link will provide better scraping and leveling action.
- Experience will allow the operator to determine the best setting for the application being done.

SCRAPING

1. Adjust the depth of the box blade by tilting the unit with the tractor top link. Shortening the top link when scraping will transfer more weight on the front of the box blade and will raise the cutting blade to provide a more shallow cut.

NOTE: When the top link is adjusted properly, the bowl of the box blade should fill easily and material can be pulled to a desired location.

2. To change the level of the box blade, shorten or lengthen the tractor lift arm tilt link to provide the correct slope.

3. Spread material by gradually raising the box blade as the tractor moves forward. Top link adjustment for loose or previously scarified material will differ from adjustment for hard or compacted material.

LEVELING

1. Shorten the top link so the cutting edge clears the ground.

2. Drive forward with the box blade in this position and loose material will be leveled.



WARNING

STORAGE

- Block equipment securely for storage (see Blocking Up Box Blade, page 11).
- Keep children and bystanders away from storage area.

Owner Service

The information in this section is written for operators who possess basic mechanical skills. If you need help, your dealer has trained service technicians available. For your protection, read and follow the safety information in this manual.

WARNING

- NEVER GO UNDERNEATH EQUIPMENT. Never place any part of the body underneath equipment or between moveable parts even when the engine has been turned off. Hydraulic system leak down, hydraulic system failures, mechanical failures, or movement of control levers can cause equipment to drop or rotate unexpectedly and cause severe injury or death.
- Service work does not require going underneath.
- Read Manual for service instructions or have service performed by a qualified dealer.

WARNING

- Keep all persons away from operator control area while performing adjustments, service, or maintenance.
- Before dismounting power unit or performing any service or maintenance, follow these steps: disengage power to equipment, lower the 3 point hitch and all raised components to the ground,

CAUTION

operate valve levers to release any hydraulic pressure, set parking brake, stop engine, remove key, and unfasten seat belt.

- Always wear relatively tight and belted clothing to avoid entanglement in moving parts. Wear sturdy, rough-soled work shoes and protective equipment for eyes, hair, hands, hearing, and head.

BLOCKING UP BOX BLADE

WARNING

NOTE: To service the box blade when attached to the tractor, it must be blocked up off the ground.

1. Place two 4" x 4" blocks under each side frame of the box blade as shown in Figure 4.
2. Lower the box blade to rest securely on the blocks.
3. Do not block the machine any higher than needed for removing the shanks or cutting edge.

Storage

When storing your box blade make sure the unit is placed on level ground and that the box blade is properly chocked by bracing with 4" x 4" blocks on the front and rear side of each end of the box blade.

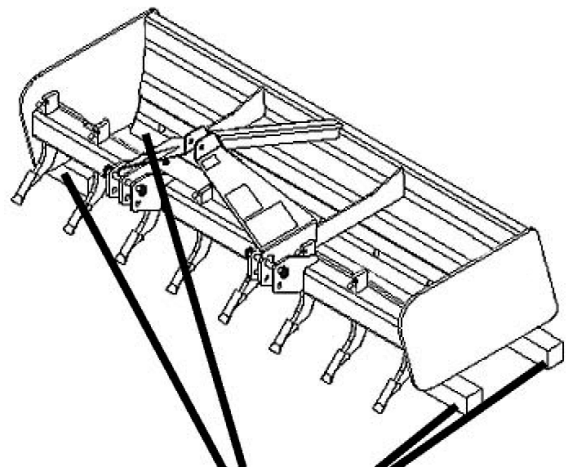

4" x 4" blocks securing gang for storage

Figure 4

REPLACING CUTTING EDGE

To service the box blade when attached to the tractor, it must be blocked up off the ground.

1. Place two 4" x 4" (10 x 10 cm) blocks under each side-frame of the box blade (see Figure 4).

2. Lower the box blade to rest securely on the blocks.

NOTE: Do not block the machine any higher than necessary to remove the shanks or cutting edge.

3. Refer to parts drawing, page 13. Remove the hex nuts (15) and plow bolts (13) from box blade. Turn cutting edge over and use new edge, or replace it if both edges have been used.

4. Attach cutting edge to box blade and secure with plow bolts and hex nuts previously removed.

5. Torque plow bolts to 170 lbs-ft. See specifications given in Bolt Torque Chart, page 15.

Figure 1

ITEM NO.	PART NUMBER	DESCRIPTION	QTY.
1	15920	CORRAL BOX FRAME 84"	11
1	15908	CORRAL BOX FRAME 96"	1
1	15921	CORRAL BOX FRAME 120"	1
2	10705	CUTTING EDGE 84"	1
2	10706	CUTTING EDGE 96"	1
2	13456	CUTTING EDGE 120"	1
3	10699	PLOW BOLT 5/8" X 1 3/4"	MS
4	T-24	LOCK WASHER 5/8"	MS
5	T-22	HEX NUT 5/8"	MS
6	13257	CAT 1 & 2 LIFT PIN	2
7	VP252	LYNCH PIN	3
8	15206	CAT 1 TOP LINK PIN	1
9	15210	CAT 2 BUSHING, 1 15/16"	1

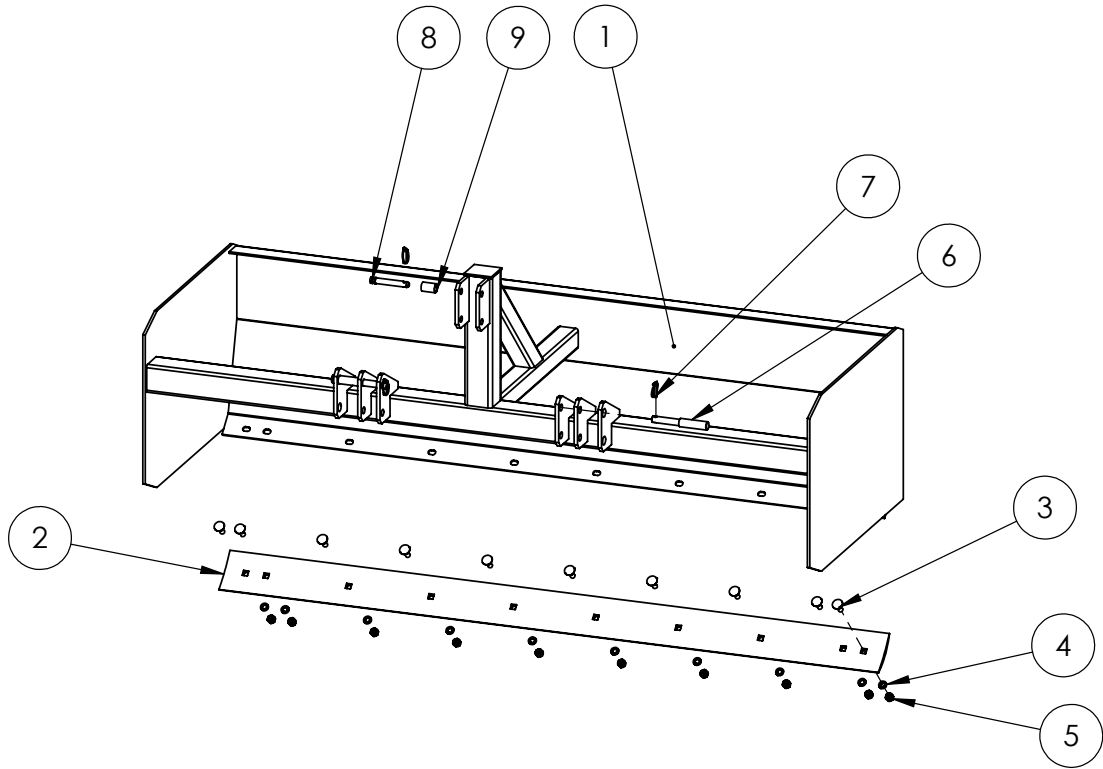

Bolt Size Chart

NOTE: Chart shows bolt thread sizes and corresponding head (wrench) sizes for standard SAE and metric bolts.

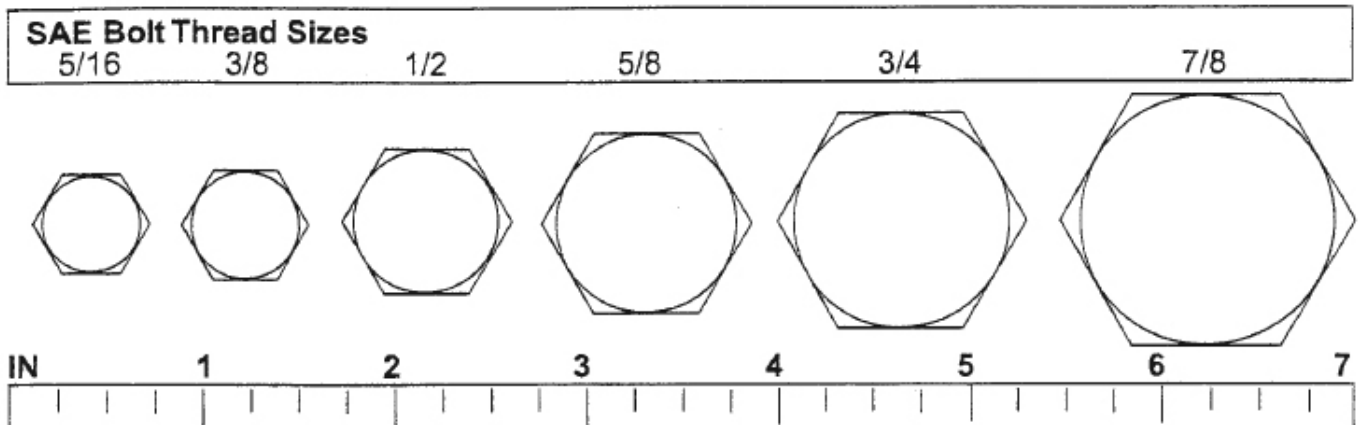

SAE Torque Chart

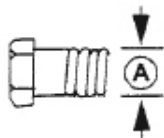

SAE SERIES TORQUE CHART

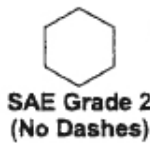

SAE Bolt Head Identification



A Diameter (Inches)	Wrench Size	MARKING ON HEAD					
		SAE 2		SAE 5		SAE 8	
		lbs-ft	N-m	lbs-ft	N-m	lbs-ft	N-m
1/4"	7/16"	6	8	10	13	14	18
5/16"	1/2"	12	17	19	26	27	37
3/8"	9/16"	23	31	35	47	49	67
7/16"	5/8"	36	48	55	75	78	106
1/2"	3/4"	55	75	85	115	120	163
9/16"	13/16"	78	106	121	164	171	232
5/8"	15/16"	110	149	170	230	240	325
3/4"	1-1/8"	192	261	297	403	420	569
7/8"	1-5/16"	306	416	474	642	669	907
1"	1-1/2"	467	634	722	979	1020	1383

13 Bolt Size and Bolt Torque Chart

PRODUCT WARRANTY

Monroe-Tufline Manufacturing Co., Inc. ("Monroe-Tufline") warrants its parts to be free from defect in material and workmanship for a period of ninety (90) days from the date of delivery of the part(s) to the original purchaser.

Replacement or repair parts installed in the equipment covered by warranty are warranted for ninety (90) days from date of purchase of such part or to the expiration of the applicable new equipment warranty period, whichever occurs later.

Under no circumstances will this Warranty apply in the event that the product the parts are installed in, in the good faith opinion of Monroe-Tufline, has been subjected to improper operation, improper maintenance, misuse, or an accident. This Warranty does not cover normal wear or tear, or normal maintenance items.

This Warranty is extended solely to the original purchaser of the product. Should the original purchaser sell or otherwise transfer this product to a third party, this Warranty does not transfer to a third party purchaser in any way. There are no third party beneficiaries of this Warranty.

Monroe-Tufline's obligation under this Warranty is limited to, at Monroe-Tufline's option, the repair or replacement, free of charge, of the product if Monroe-Tufline, in its sole discretion, deems it to be defective or in noncompliance with this Warranty. The selling dealer shall provide such parts to the user during regular working hours. If requested, the product must be returned to Monroe-Tufline with proof of purchase within thirty (30) days after such defect or noncompliance is discovered or should have been discovered, routed through the dealer and distributor from whom the purchase was made, transportation charges prepaid. Monroe-Tufline shall complete such repair or replacement within a reasonable time after Monroe-Tufline receives the product. THERE ARE NO OTHER REMEDIES UNDER THIS WARRANTY. THE REMEDY OF REPAIR OR REPLACEMENT IS THE SOLE AND EXCLUSIVE REMEDY UNDER THIS WARRANTY.

THERE ARE NO WARRANTIES WHICH EXTEND BEYOND THE DESCRIPTION ON THE FACE OF THIS WARRANTY. MONROE-TUFLINE MAKES NO OTHER WARRANTY, EXPRESS OR IMPLIED, AND MONROE-TUFLINE SPECIFICALLY DISCLAIMS ANY IMPLIED WARRANTY OF MERCHANTABILITY AND/OR ANY IMPLIED WARRANTY OF FITNESS FOR A PARTICULAR PURPOSE (EXCEPT WHERE PROHIBITED BY LAW).

Monroe-Tufline shall not be liable for any incidental or consequential losses, damages or expenses, arising directly or indirectly from the product, whether such claim is based upon breach of contract, breach of warranty, negligence, strict liability in tort or any other legal theory. Without limiting the generality of the foregoing, Monroe-Tufline specifically disclaims any damages relating to (i) lost profits, business, revenues or goodwill; (ii) loss of crops; (iii) loss because of delay in harvesting; (iv) any expense or loss incurred for labor, supplies, substitute machinery or rental; or (v) any other type of damage to property or economic loss.

This Warranty is subject to any existing conditions of supply which may directly affect Monroe-Tufline's ability to obtain materials or manufacture replacement parts.

No agent, representative, dealer, distributor, service person, salesperson, or employee of any company, including without limitation, Monroe-Tufline, its authorized dealers, distributors, and service centers, is authorized to alter, modify, or enlarge this Warranty.

For warranty services, contact your selling dealer.

**PART NO.
15992**

Tufline[®]