

AGRICULTURAL MACHINERY
sitrex®
Spa

SPARE PARTS LIST

BR 2030/6 Basket Rake 6 bars
BR 2030/7 Basket Rake 7 bars

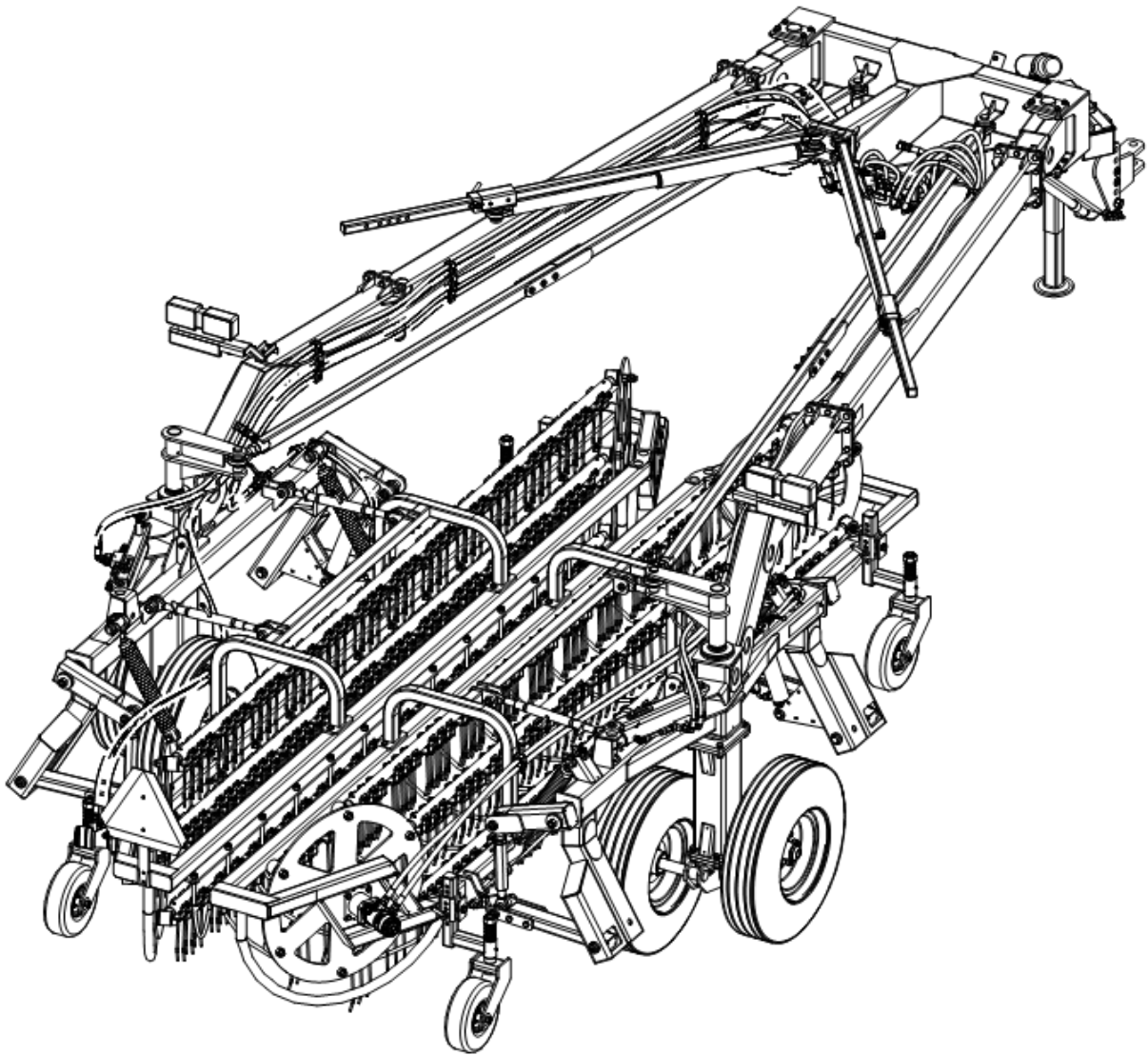

*Order spare parts together with the
Product Identification Number (PIN) of the machine*

DRAWBAR

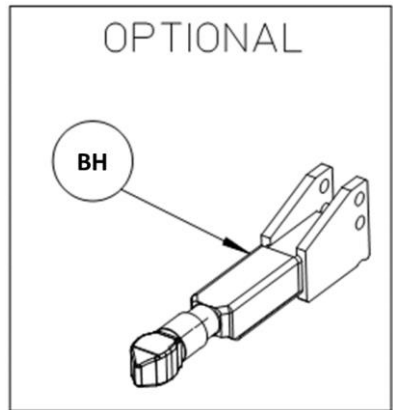
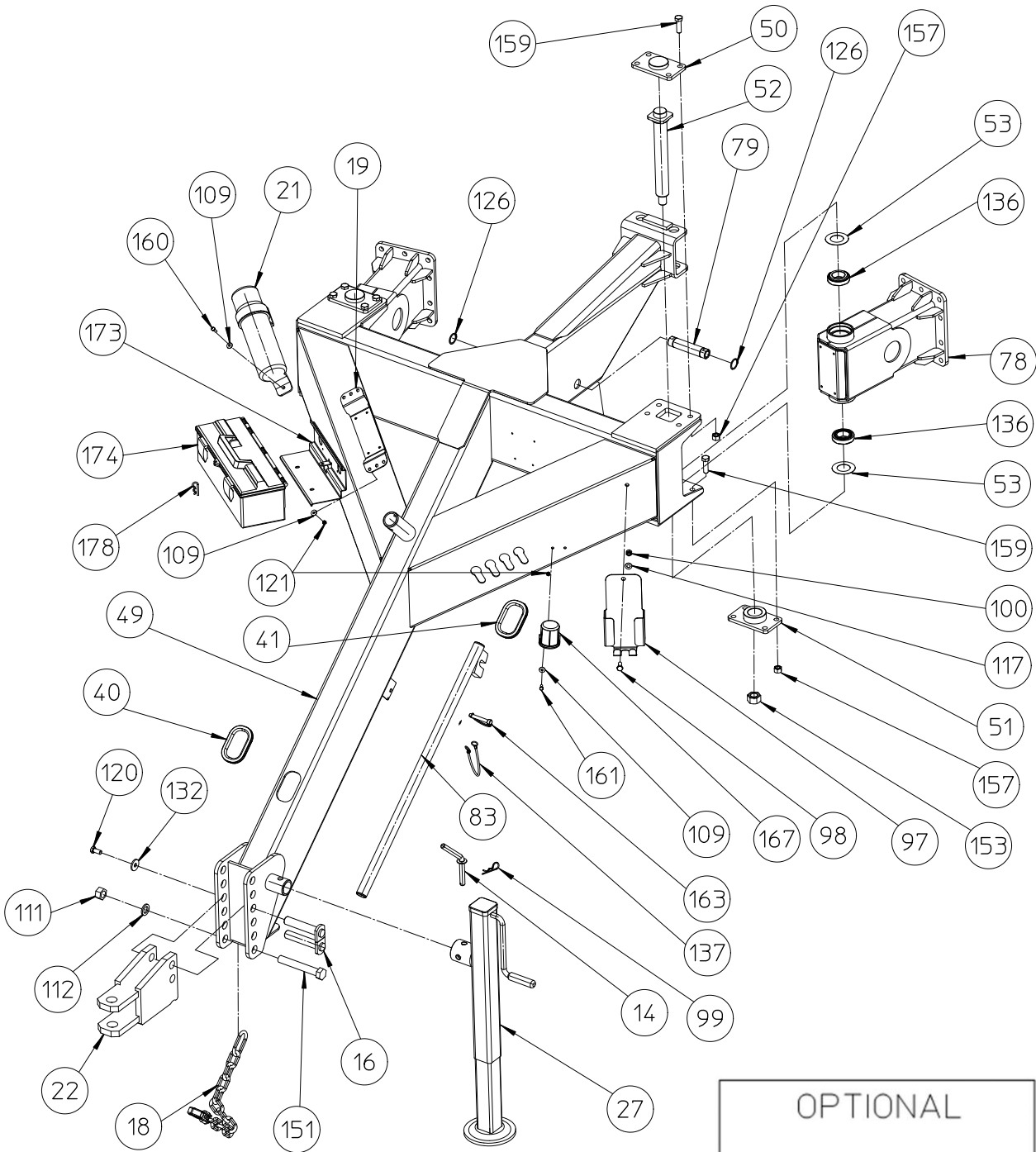

DRAWBAR				
ITEM	PART N°	QTY	DESCRIPTION	NOTE
14	200.222	1	PIN ϕ 15X85	
16	200.828	2	PIN ϕ 25X125	
18	220.500	1	SAFETY CHAIN	
19	225.195	1	CANISTER BRACKET	
21	230.457	1	CANISTER	
22	250.271	1	TRACTOR HITCH	
27	250.775	1	PARKING STAND	
40	270.077	1	CORD PROTECTOR	
41	270.078	1	CORD PROTECTOR	
49	270.128	1	DRAWBAR	
50	270.130	2	UPPER CAP	
51	270.131	2	LOWER CAP	
52	270.133	2	SECTION PIN ϕ 40X306	
53	270.136	4	DUST COVER	
78	270.206	2	SECTION	
79	270.208	1	FITTING 1/2" GAS	
83	270.216	1	ADJUSTMENT KEY	
97	520.677	1	JOYSTICK SUPPORT	
98	600.006	1	SCREW M10 X 25 UNI 5739 8.8 ZN	
99	600.019	1	HAIRPIN ϕ 3	
100	600.029	1	NUT CL M10 DIN 980 KL.8 ZN	
109	600.135	8	WASHER D 6.6X18X1.6 UNI 6593 ZN	
111	600.200	1	NUT M22 UNI 5588 6S ZN	
112	600.214	1	SPRING WASHER D 23 UNI 1751A ZN	
117	600.322	1	WASHER D 10,5 UNI 6592 ZN	
120	600.441	2	SCREW M12 X 25 UNI 5739 8.8 ZN	
121	600.472	3	NUT CL M 6 DIN 980 KL.8 ZN	
126	600.611	2	SEEGER E 30 UNI 7435	
132	600.845	2	WASHER D 12/36 X 4 ZN	
136	601.029	4	BEARING 32008 40X68X19	
137	601.066	1	RUBBER ROPE	
151	620.019	1	SCREW M22 X150 UNI 5737 8.8 ZN	
153	620.255	2	NUT CL M24 DIN 980 KL.8 ZN	
157	620.441	16	NUT CL M14 DIN 980 KL.10 ZN	
159	620.783	16	SCREW M14 X 45 UNI 5739 10.9 ZN	
160	630.003	3	SCREW M 6 X 20 UNI 5739 8.8 ZN	
161	630.104	2	SCREW M 6 x 16 UNI 5739 8.8 ZN	
163	600.842	1	PIN FOR KEY	
167	640.056	1	CAP FOR PLUG	
173	275.473	1	TOOLBOX BRACKET	
174	601.139	1	TOOLBOX	
178	600.308	1	HAIRPIN ϕ 4	
BH	250.834	1	BALL TRACTOR HITCH	

SECTION

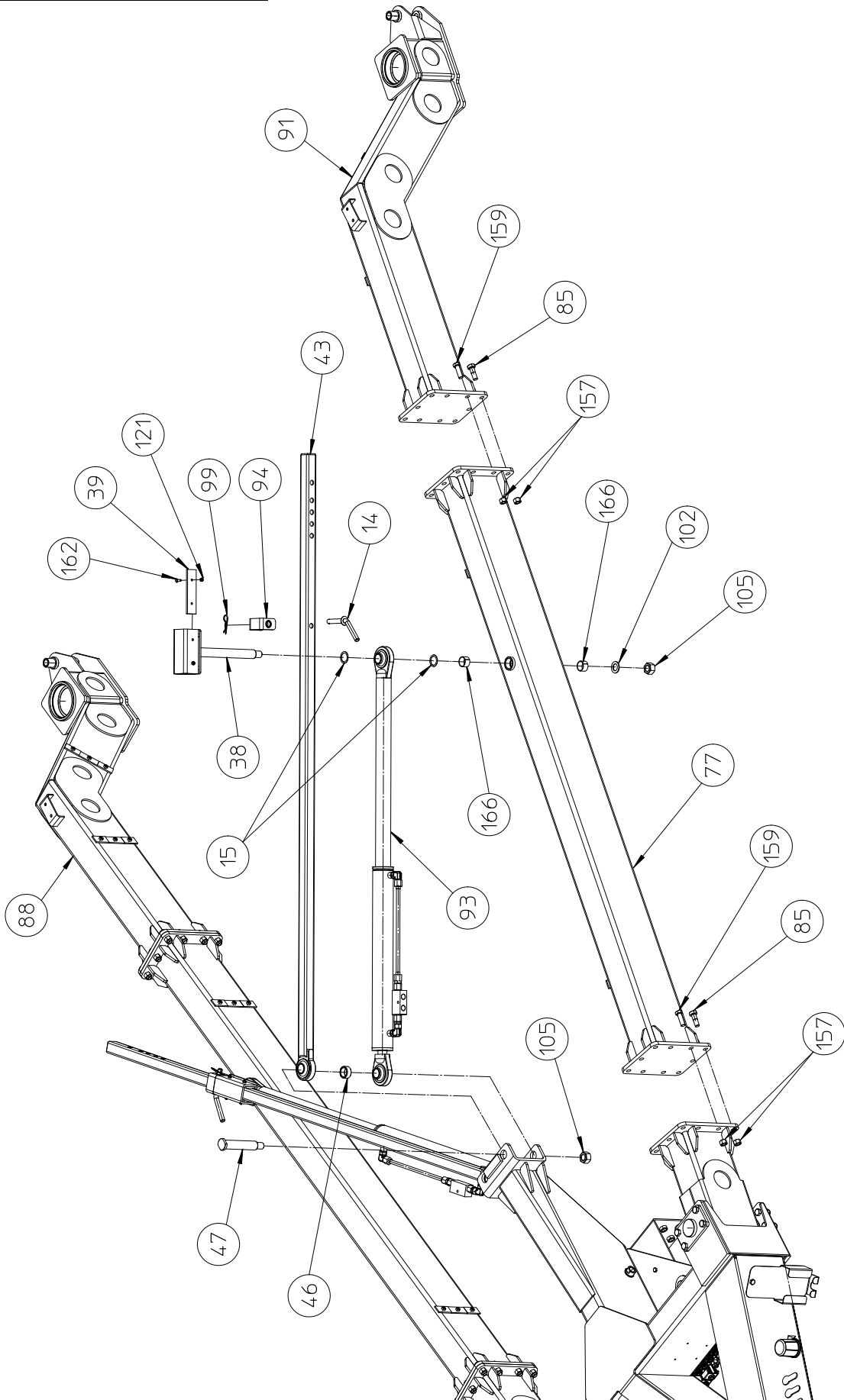

SECTION				
ITEM	PART N°	QTY	DESCRIPTION	NOTE
14	200.222	2	PIN ϕ 15X85	
15	200.273	4	SPACER 30,3/39,8X1	
38	270.075	2	SUPPORT INDICATOR	
39	270.076	6	SLIDE	
43	270.092	2	FOLD/UNFOLD BAR	
46	270.111	2	SPACER	
47	270.112	2	PIN ϕ 30X171	
77	270.205	2	CENTRAL SECTION	
85	270.224	16	PIN ϕ 15X45	
88	270.237	1	TERMINAL SECTION RH	
91	270.252	1	TERMINAL SECTION LH	
93	270.255	2	FOLD/UNFOLD CYLINDER	
94	270.259	2	STOP UNFOLD	
99	600.019	2	HAIRPIN ϕ 3	
102	600.042	2	WASHER D 23 UNI 6592 ZN	
105	600.079	4	NUT CL M22 DIN 980 KL.8 ZN	
121	600.472	12	NUT CL M 6 DIN 980 KL.8 ZN	
157	620.441	40	NUT CL M14 DIN 980 KL.10 ZN	
159	620.783	24	SCREW TE M14 X 45 UNI 5739 10.9 ZN	
162	630.483	12	SCREW M 6 X 20 UNI 5933 10.9 ZN	
166	640.043	4	BUSHING GLYCODUR D.30/34 X 20	

BASKET SUPPORT - TANDEM

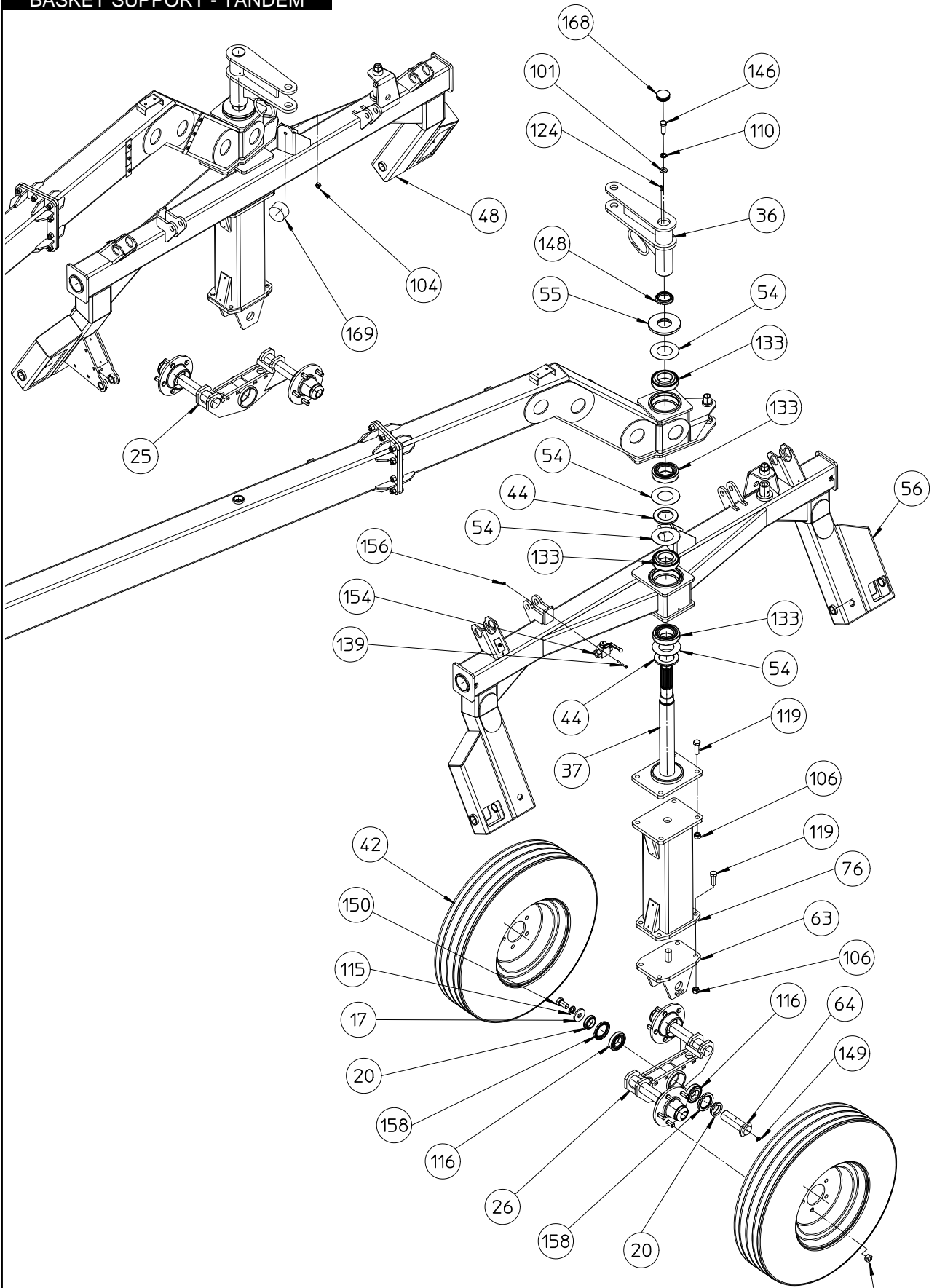

NEXT PAGE

BASKET SUPPORT - TANDEM				
ITEM	PART N°	QTY	DESCRIPTION	NOTE
17	220.469	2	WASHER D 21/56 x 6	
20	230.290	4	SPACER	
25	250.581	1	TANDEM SUPPORT RH	
26	250.582	1	TANDEM SUPPORT LH	
36	270.063	2	WHEEL LEVER	
37	270.064	2	WHEEL SHAFT	
42	270.086	4	WHEEL 235/75-R15	
44	270.096	4	SPACER 61X100X8	
48	270.126	1	BASKET SUPPORT RH	
54	270.137	8	DUST COVER	
55	270.138	2	UPPER SPACER	
56	270.141	1	BASKET SUPPORT LH	
63	270.159	2	TANDEM BRACKET	
64	270.162	2	PIN \varnothing 40X124	
76	270.202	2	WHEEL COLUMN	
101	600.031	2	WASHER D 17 UNI 6592 ZN	
104	600.077	2	NUT CL M12 DIN 980 KL.8 ZN	
106	600.080	16	NUT CL M16 DIN 980 KL.8 ZN	
110	600.180	2	SPRING WASHER D 17 UNI 1751A ZN	
115	600.259	2	SPRING WASHER D 21 UNI 1751A ZN	
116	600.285	4	BEARING 30208	
119	600.384	16	SCREW M16 X 50 UNI 5739 8.8 ZN	
124	600.580	2	SPRING PIN D 6 X 26 UNI 6873	
133	601.017	8	BEARING 32212	
139	601.117	4	SCREW M 5 X 50 UNI 5737 8.8 ZN	
146	610.167	2	SCREW M16 X 45 UNI 5739 8.8 ZN	
148	610.316	2	LOCKING RING M55x2 ZN	
149	610.900	2	GREASER M6X90°	
150	610.931	2	SCREW M20X1.5 X 35 UNI 5740 8.8 ZN	
154	620.314	2	VALVE	
156	620.367	4	NUT CL M 5 DIN 980 KL.8 ZN	
158	620.530	4	GASKET 56/80X8	
168	640.336	2	CAP D.55x1-3	
169	640.679	2	SILENT BLOK 70/40 M12/37	

TANDEM HUB - WHEEL

TANDEM HUB 215.960

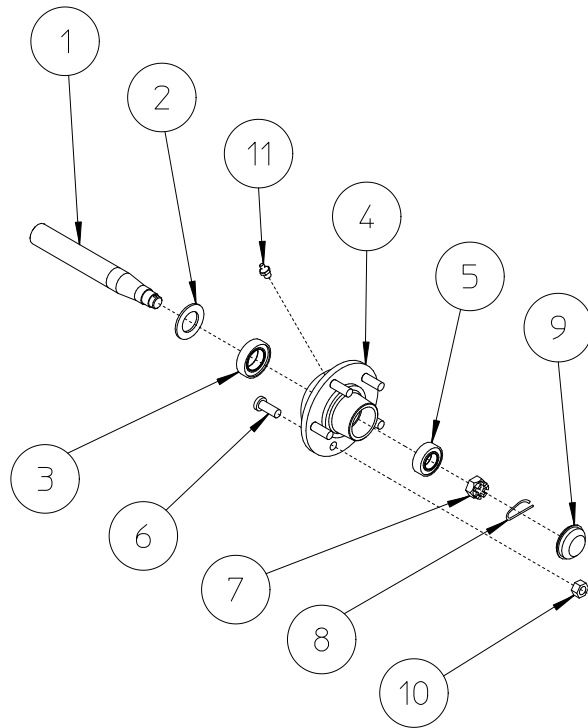

WHEEL 270.086

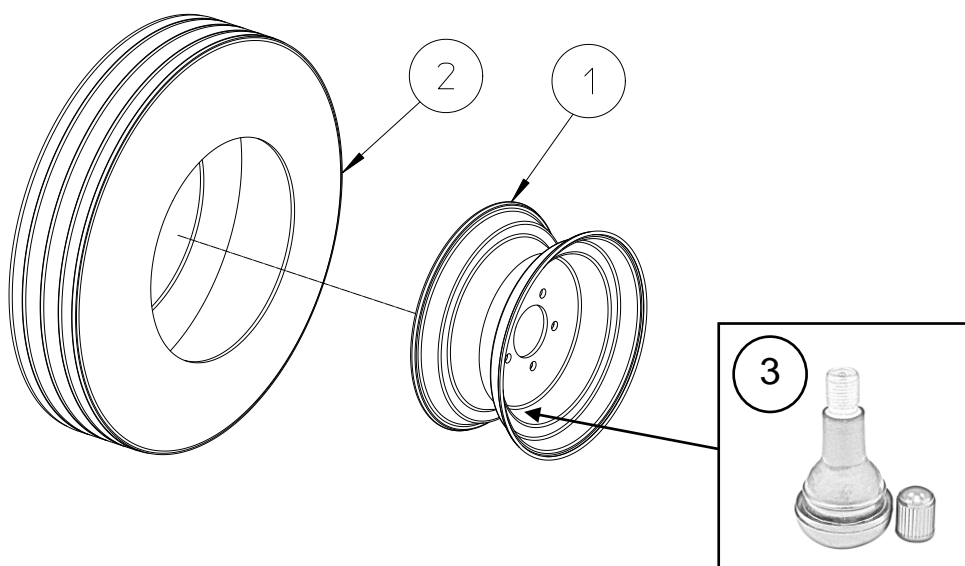

TANDEM HUB 215.960				
ITEM	PART N°	QTY	DESCRIPTION	NOTE
1	215.959	4	PIN ø 45	
2	600.284	4	DUST COVER	
3	600.285	4	BEARING 30208	
4	600.286	4	HUB WITH SCREWS	
5	600.287	4	BEARING 30206	
6	610.413	20	SCREW M16X1,5X50	
7	600.288	4	SLOTTED NUT M27X1,5	
8	600.291	4	SPLIT PIN ø 3	
9	600.290	4	CAP	
10	600.289	20	NUT M16X1,5	
11	600.034	4	GREASER M8	

WHEEL 270.086				
ITEM	PART N°	QTY	DESCRIPTION	NOTE
1	600.304	4	RIME 6JX15	
2	601.022	4	TIRE 235/75 R15	
3	620.101	4	TUBELESS VALVE TR413-42.5X11.5	

BASKET SUPPORT

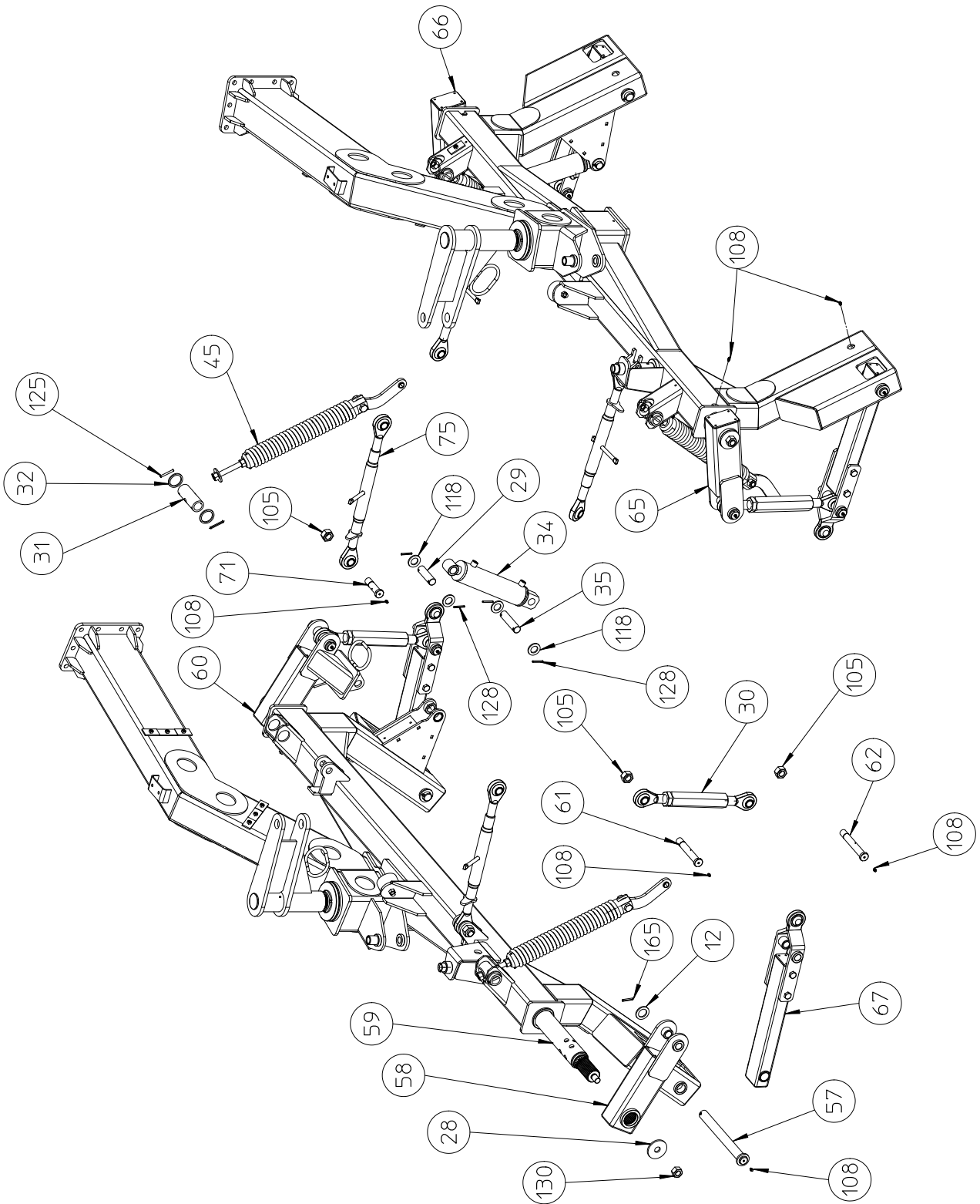

BASKET SUPPORT				
ITEM	PART N°	QTY	DESCRIPTION	NOTE
12	110.135	4	WASHER D.31X48X4	
28	270.037	4	WASHER 21/70X6	
29	270.038	2	PIN ϕ 25X89	
30	270.043	4	LOWER TIE ROD	
31	270.046	4	BUSHING FOR SPRING	
32	270.047	8	SPACER ϕ 42,5/52 SP.4	
34	270.056	2	LIFT CYLINDER ϕ 60/30X170	
35	270.057	2	PIN ϕ 25X107	
45	270.109	4	BASKET FLOATING SPRING	
57	270.144	4	PIN ϕ 30X306	
58	270.145	1	LIFT ARM LH	
59	270.146	2	LIFT SHAFT	
60	270.147	1	LIFT ARM FOR CYLINDER LH	
61	270.148	4	UPPER PIN ϕ 22X146	
62	270.151	4	LOWER PIN ϕ 22X162	
65	270.165	1	LIFT ARM RH	
66	270.166	1	LIFT ARM FOR CYLINDER RH	
67	270.174	4	LOWER ARM	
71	270.191	4	TIE ROD PIN ϕ 22X86	
75	270.200	4	UPPER TIE ROD	
105	600.079	12	NUT CL M22 DIN 980 KL.8 ZN	
108	600.124	20	GREASER M6	
118	600.336	8	WASHER D25	
125	600.585	8	SPRING PIN D6 X 50	
128	600.673	8	SPRING PIN D6 X 40	
130	600.717	4	NUT CL M20 DIN 980 KL.8 ZN	
165	640.007	4	SPRING PIN D6 X 40 UNI 6873	

BASKET SUPPORT COMPONENTS

BASKET FLOATING SPRING 270.109

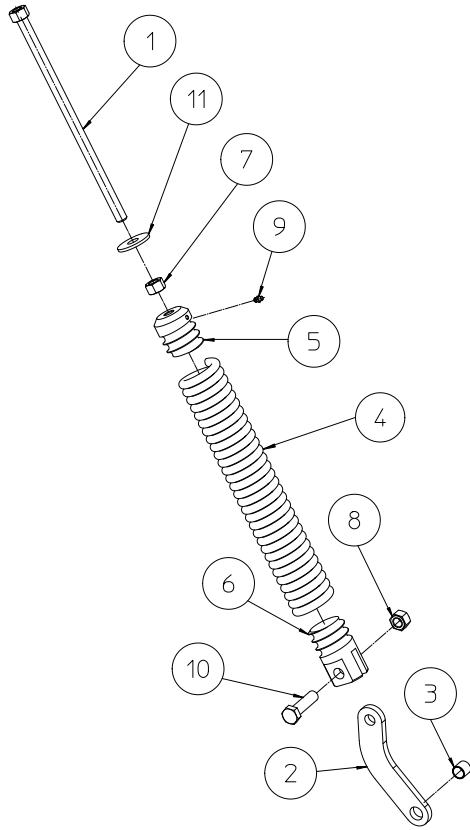

LOWER TIE ROD 270.043

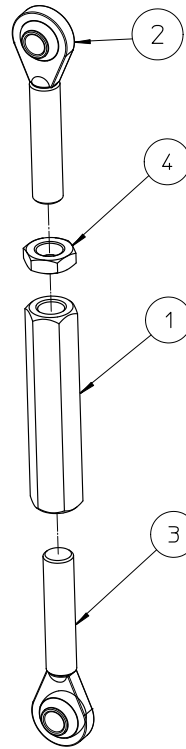

UPPER TIE ROD 270.200

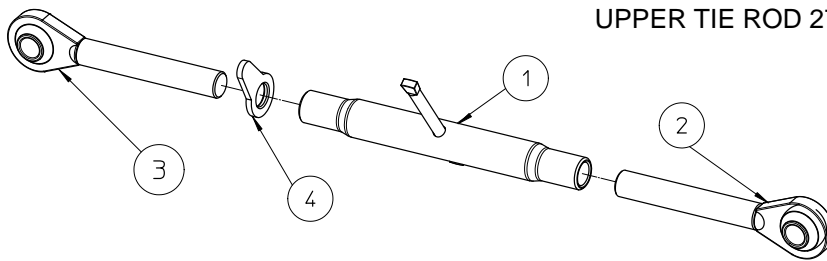

LOWER ARM 270.174

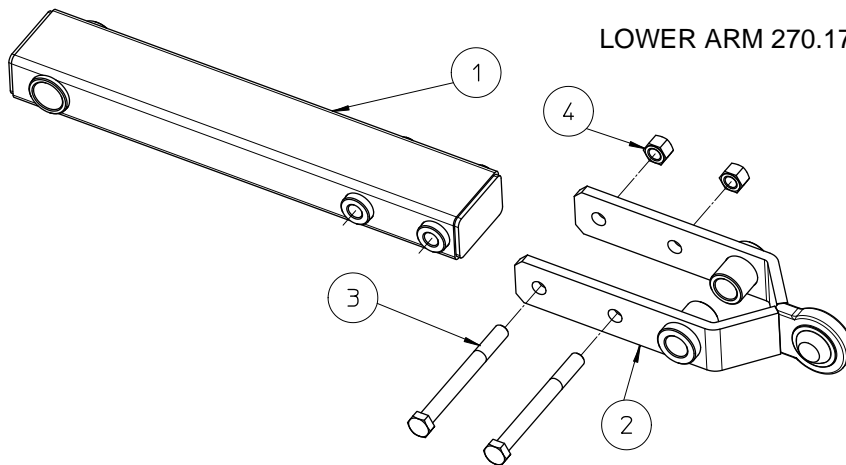

BASKET FLOATING SPRING 270.109				
ITEM	PART N°	QTY	DESCRIPTION	NOTE
1	270.049	1	ROD	
2	270.050	1	LEVER	
3	270.110	1	BUSH	
4	270.226	1	SPRING	
5	270.227	1	UPPER CAP	
6	270.228	1	LOWER CAP	
7	600.032	1	NUT M16 UNI 5588 6S ZN	
8	600.080	1	NUT M16 DIN 980 KL.8 ZN	
9	600.124	1	GREASER M 6	
10	600.174	1	SCREW M16 X 60 UNI 5737 8.8 ZN	
11	600.741	1	WASHER D 18 UNI 6593 ZN	

LOWER TIE ROD 270.043				
ITEM	PART N°	QTY	DESCRIPTION	NOTE
1	270.041	1	TIE ROD CENTRAL BODY	
2	270.042	1	TERMINAL M30 RH	
3	270.044	1	TERMINAL M30 LH	
4	610.813	1	NUT M30	

UPPER TIE ROD 270.200				
ITEM	PART N°	QTY	DESCRIPTION	NOTE
1	270.196	1	TIE ROD CENTRAL BODY	
2	270.197	1	TERMINAL M30 LH	
3	270.198	1	TERMINAL M30 RH	
4	270.199	1	NUT M27	

LOWER ARM 270.174				
ITEM	PART N°	QTY	DESCRIPTION	NOTE
1	270.150	1	ARM	
2	270.152	1	BASKET LINK	
3	610.612	2	SCREW M14 X140 UNI 5737 8.8 ZN	
4	620.441	2	NUT M14 DIN 980 KL.10 ZN	

BASKET LH

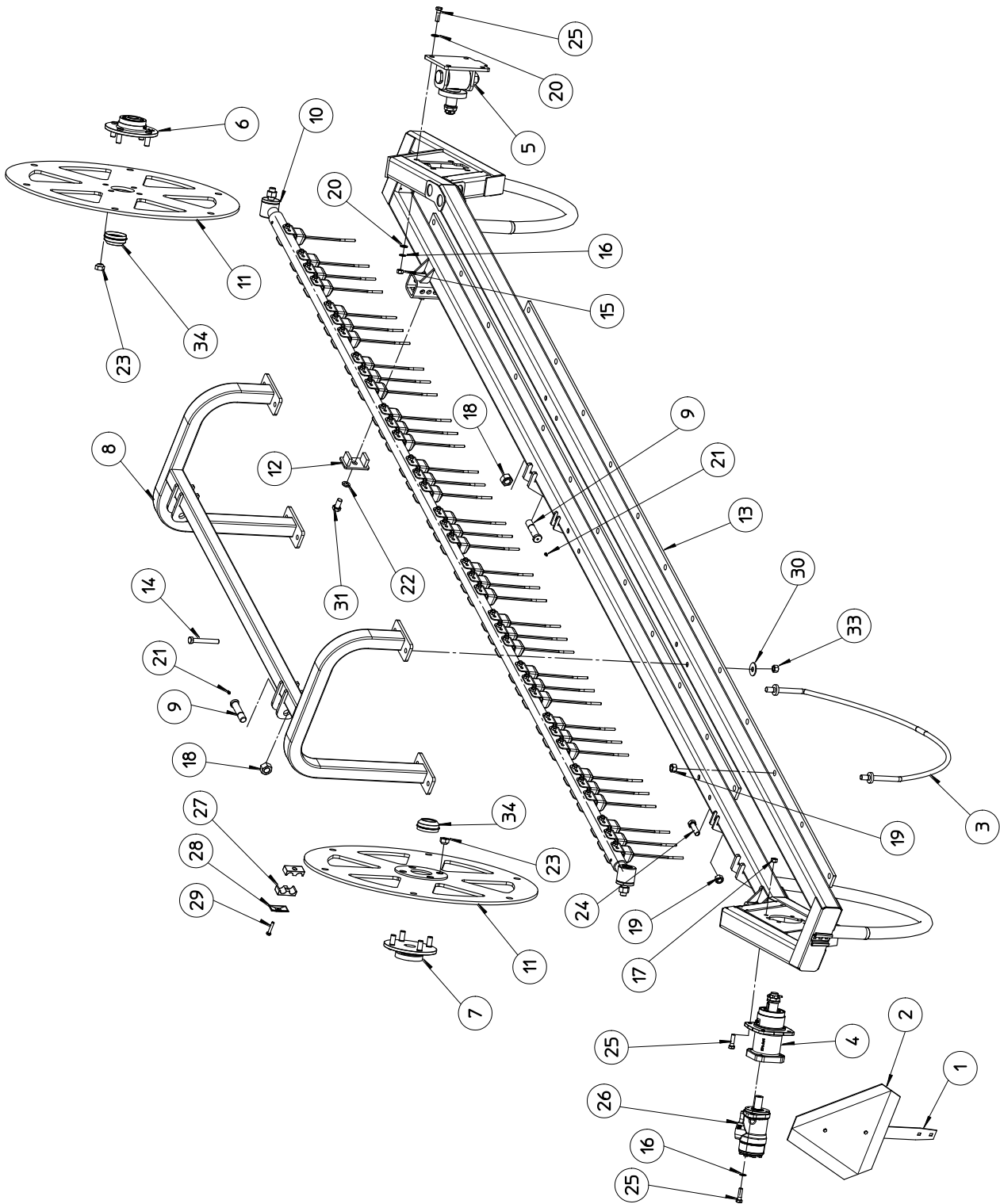

BASKET 6 BARS LH 270.261 (BASKET 7 BARS LH 270.263)				
ITEM	PART N°	QTY	DESCRIPTION	NOTE
1	220.413	1	SIGNAL SUPPORT	
2	220.414	1	SIGNAL	
3	270.132	12	STRIPPER BAR	
4	270.276	1	MOTOR TRANSMISSION	
5	270.176	1	IDLER WHEEL SUPPORT LH	
6	270.275	1	IDLER HUB	
7	270.274	1	MOTOR HUB	
8	270.183	1	CAGE LH	
9	270.191	4	PIN \varnothing 22X86	
10	270.221	6	TINE BAR LH	Q.TY 7 FOR 7 BARS
11	270.222	2	6 BARS WHEEL	270.018 FOR 7 BARS
12	270.243	2	CASTOR WHEEL CLAMP	
13	270.253	1	BASKET FRAME LH	
14	600.003	8	SCREW M14 X100 UNI 5737 8.8 ZN	
15	600.008	4	NUT M12 UNI 5588 6S ZN	
16	600.018	6	GROWER D 13	
17	600.077	4	NUT CL M12 DIN 980 KL.8 ZN	
18	600.079	4	NUT CL M22 DIN 980 KL.8 ZN	
19	600.080	26	NUT CL M16 DIN 980 KL.8 ZN	
20	600.089	8	WASHER D 13 UNI 6592 ZN	
21	600.124	4	GREASER M6	
22	600.180	2	GROWER D 17	
23	600.289	8	CENTERING NUT M16	
24	600.384	2	SCREW M16 X 50 UNI 5739 8.8 ZN	
25	640.218	10	SCREW M12 X 40 UNI 5737 10.9 ZN	
26	601.001	1	ORBITAL MOTOR OMPX200	FOR UNITS BEFORE PIN 307663 (INCLUDED)
	601.190	1	ORBITAL MOTOR OMPX315	FOR UNITS AFTER PIN 307663
27	610.041	2	HALF HOSE COLLAR AD3 22-22 S	
28	610.043	1	HOSE COLLAR PLATE ADPS 3	
29	610.044	1	SCREW M 8 X 45 UNI 5739 4.8 ZN	
30	610.231	8	WASHER D 16 UNI 6593 ZN	
31	610.940	2	SCREW M16 X 30 UNI 5739 8.8 ZN	
33	620.441	8	NUT CL M14 DIN 980 KL.10 ZN	
34	630.449	2	CAP	

BASKET RH

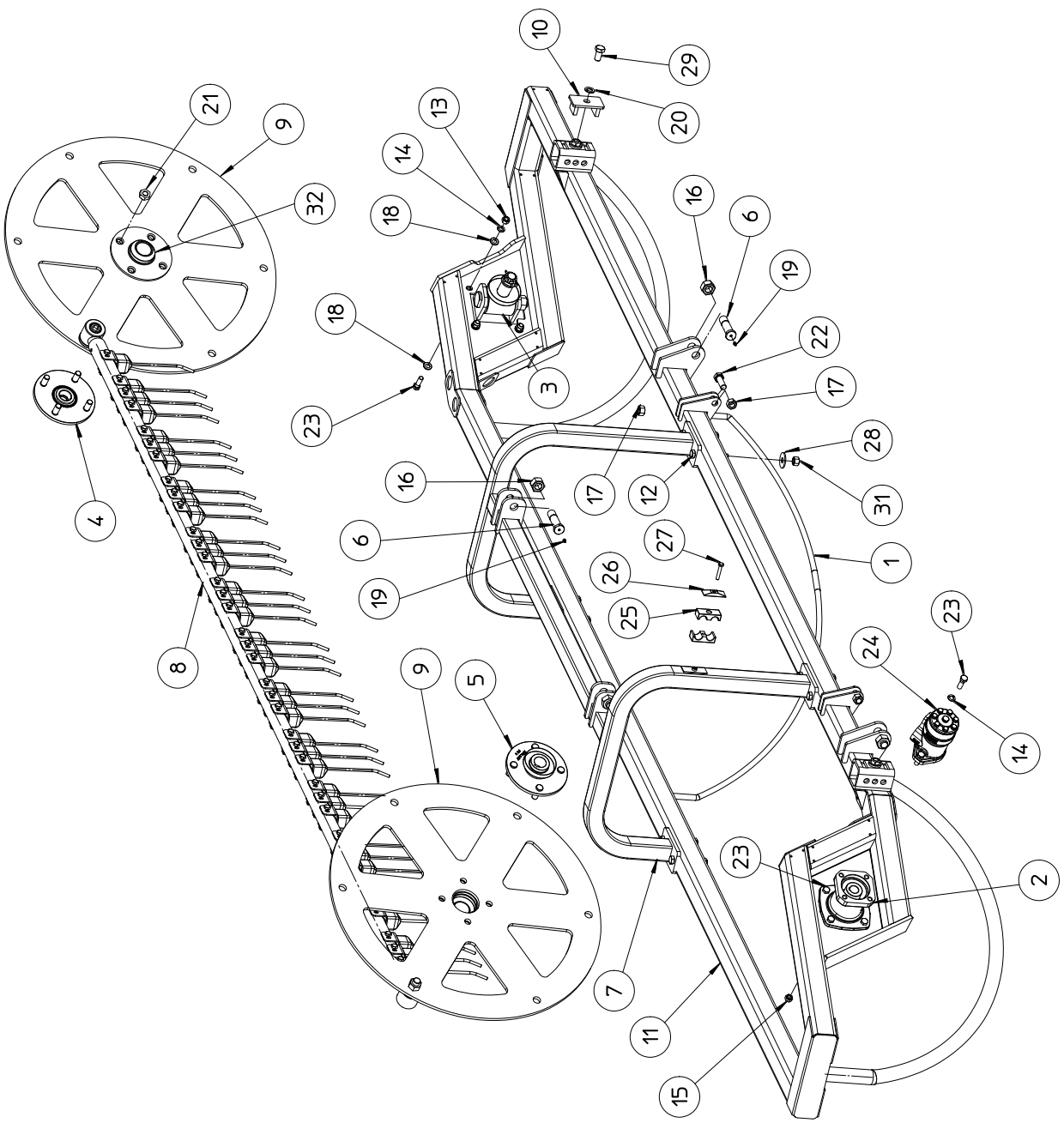

BASKET 6 BARS RH 270.262 (BASKET 7 BARS RH 270.264)				
ITEM	PART N°	QTY	DESCRIPTION	NOTE
1	270.132	12	STRIPPER BAR	
2	270.276	1	MOTOR TRANSMISSION	
3	270.177	1	IDLER WHEEL SUPPORT RH	
4	270.275	1	IDLER HUB	
5	270.274	1	MOTOR HUB	
6	270.191	4	PIN ø22X86	
7	270.212	1	CAGE RH	
8	270.220	6	TINE BAR RH	Q.TY 7 FOR 7 BARS
9	270.222	2	6 BARS WHEEL	270.018 FOR 7 BARS
10	270.243	2	CASTOR WHEEL CLAMP	
11	270.251	1	BASKET FRAME RH	
12	600.003	8	SCREW M14 X100 UNI 5737 8.8 ZN	
13	600.008	4	NUT M12 UNI 5588 6S ZN	
14	600.018	6	GROWER D 13	
15	600.077	4	NUT CL M12 DIN 980 KL.8 ZN	
16	600.079	4	NUT CL M22 DIN 980 KL.8 ZN	
17	600.080	26	NUT CL M16 DIN 980 KL.8 ZN	
18	600.089	8	WASHER D 13 UNI 6592 ZN	
19	600.124	4	GREASER M6	
20	600.180	2	GROWER D 17	
21	600.289	8	CENTERING NUT M16	
22	600.384	2	SCREW M16 X 50 UNI 5739 8.8 ZN	
23	640.218	10	SCREW M12 X 40 UNI 5737 10.9 ZN	
24	601.001	1	ORBITAL MOTOR OMPX200	FOR UNITS BEFORE PIN 307663 (INCLUDED)
	601.190	1	ORBITAL MOTOR OMPX315	FOR UNITS AFTER PIN 307663
25	610.041	2	HALF HOSE COLLAR AD3 22-22 S	
26	610.043	1	HOSE COLLAR PLATE ADPS 3	
27	610.044	1	SCREW M 8 X 45 UNI 5739 4.8 ZN	
28	610.231	8	WASHER D 16 UNI 6593 ZN	
29	610.940	2	SCREW M16 X 30 UNI 5739 8.8 ZN	
31	620.441	8	NUT CL M14 DIN 980 KL.10 ZN	
32	630.449	2	CAP	

BASKET COMPONENTS

MOTOR HUB 270.274

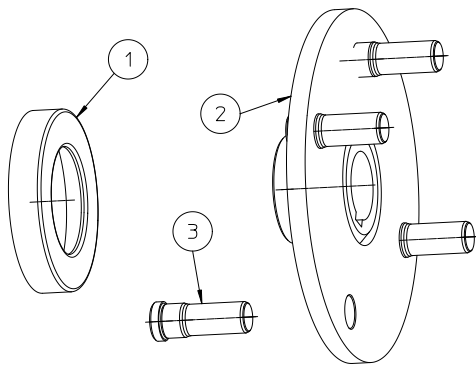

IDLER HUB 270.275

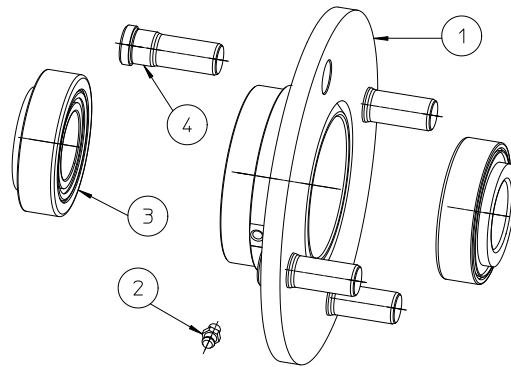

MOTOR TRANSMISSION 270.276

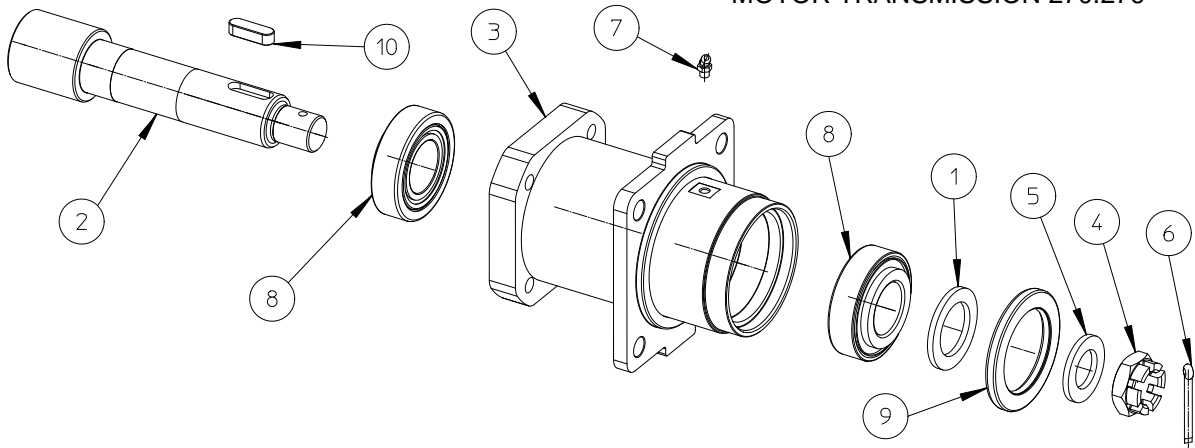

IDLER WHEEL SUPPORT LH (RH) 270.176 (270.177)

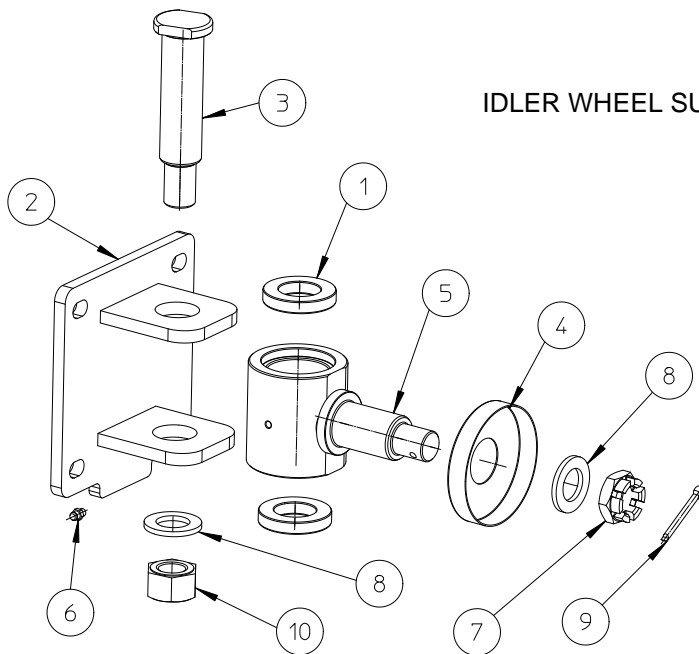

MOTOR HUB 270.274				
ITEM	PART N°	QTY	DESCRIPTION	NOTE
1	270.268	1	CAP	
2	270.271	1	HUB	
3	610.413	4	CENTERING SCREW M16	

IDLER HUB 270.275				
ITEM	PART N°	QTY	DESCRIPTION	NOTE
1	270.272	1	HUB	
2	600.124	1	GREASER M6	
3	601.140	2	BEARING 32207 J2/Q - 35X72X24.25	
4	610.413	4	CENTERING SCREW M16	

MOTOR TRANSMISSION 270.276				
ITEM	PART N°	QTY	DESCRIPTION	NOTE
1	270.003	1	WASHER 36X54X4	
2	270.269	1	MOTOR SHAFT	
3	270.270	1	CASE	
4	600.296	1	NOTCHED NUT M24X2	
5	600.336	1	WASHER D 25 UNI 6592 ZN	
6	600.348	1	SPRING	
7	600.968	1	GREASER M6X45	
8	601.140	2	BEARING 32207 J2/Q - 35X72X24.25	
9	601.141	1	RING CR 55x80x8 HMSA7 R	
10	630.031	1	KEY A 10 X 8 X 32	

IDLER WHEEL SUPPORT LH (RH) 270.176 (270.177)				
ITEM	PART N°	QTY	DESCRIPTION	NOTE
1	270.012	2	BUSH 32.5X56X10	
2	270.017	1	BRACKET	
3	270.201	1	PIVOT SHAFT	
4	270.267	1	CAP	
5	270.273	1	PIVOT	
6	600.124	1	GREASER M6	
7	600.296	1	NOTCHED NUT M24X2	
8	600.336	2	WASHER D 25 UNI 6592 ZN	
9	600.348	1	SPRING	
10	620.255	1	NUT M24 KL	

BASKET COMPONENTS

TINE BAR LH (RH) 270.221 (270.220)

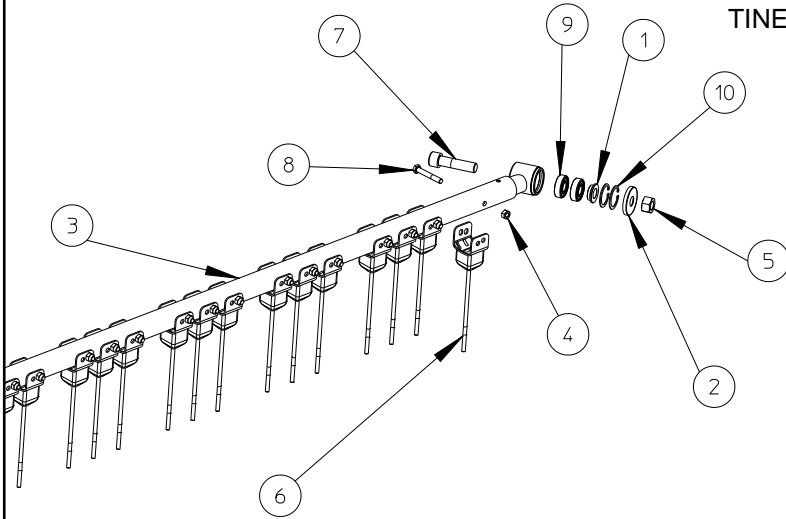

CASTOR WHEEL 270.234

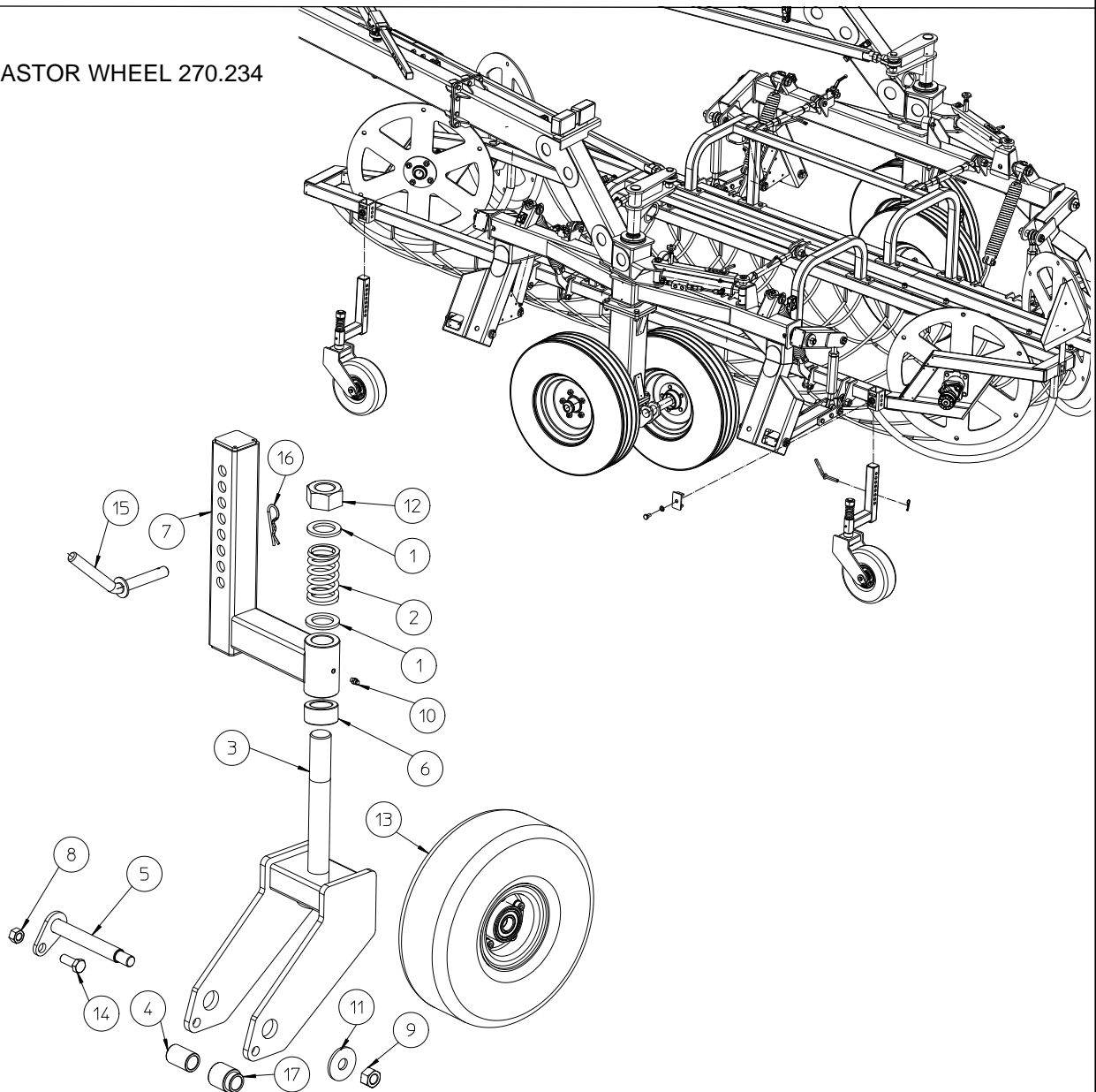

TINE BAR LH (RH) 270.221 (270.220)				
ITEM	PART N°	QTY	DESCRIPTION	NOTE
1	270.266	2	SPACER	
2	270.027	2	CAP	
3	270.172	1	TINE BAR	
4	600.029	37	NUT M10 KL DIN 980 KL.8 ZN	
5	600.717	2	NUT M20 KL DIN 980 KL.8 ZN	
6	601.011	37	TINE LH	601.028 FOR RH
7	601.143	2	SCREW M20 X 80 UNI 5931 12.9 GEOMET321	
8	610.540	37	SCREW M10 X 70 UNI 5737 8.8 ZN	
9	620.821	4	BEARING 6204 2RS	
10	620.822	4	SEEGER I 47 UNI 7437	

CASTOR WHEEL 270.234				
ITEM	PART N°	QTY	DESCRIPTION	NOTE
1	110.135	2	WASHER D.31X48X4	
2	270.030	1	COMPRESSION SPRING	
3	270.229	1	BRACKET	
4	270.230	1	PLAIN WHEEL SPACER	
5	270.231	1	WHEEL SHAFT	
6	270.232	1	LOWER SPACER	
7	270.233	1	SUPPORT	
8	600.077	1	NUT M12 DIN 980 KL.8 ZN	
9	600.080	1	NUT M16 DIN 980 KL.8 ZN	
10	600.124	1	GREASER M6	
11	600.741	1	WASHER D 18 UNI 6593 ZN	
12	601.021	1	NUT M30 DIN 980 KL.8 ZN	
13	601.073	1	WHEEL 4.00-4/2.50	
14	610.962	1	SCREW M12 X 30 M12 X 30 UNI 5739 8.8 ZN	
15	200.222	1	PIN ϕ 15X85	
16	600.019	1	SPLIT PIN ϕ 3	
17	270.258	1	WHEEL SPACER	

TIE RODS

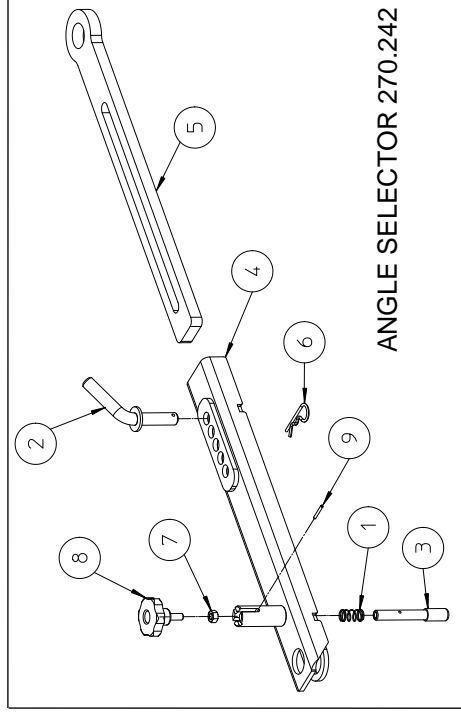
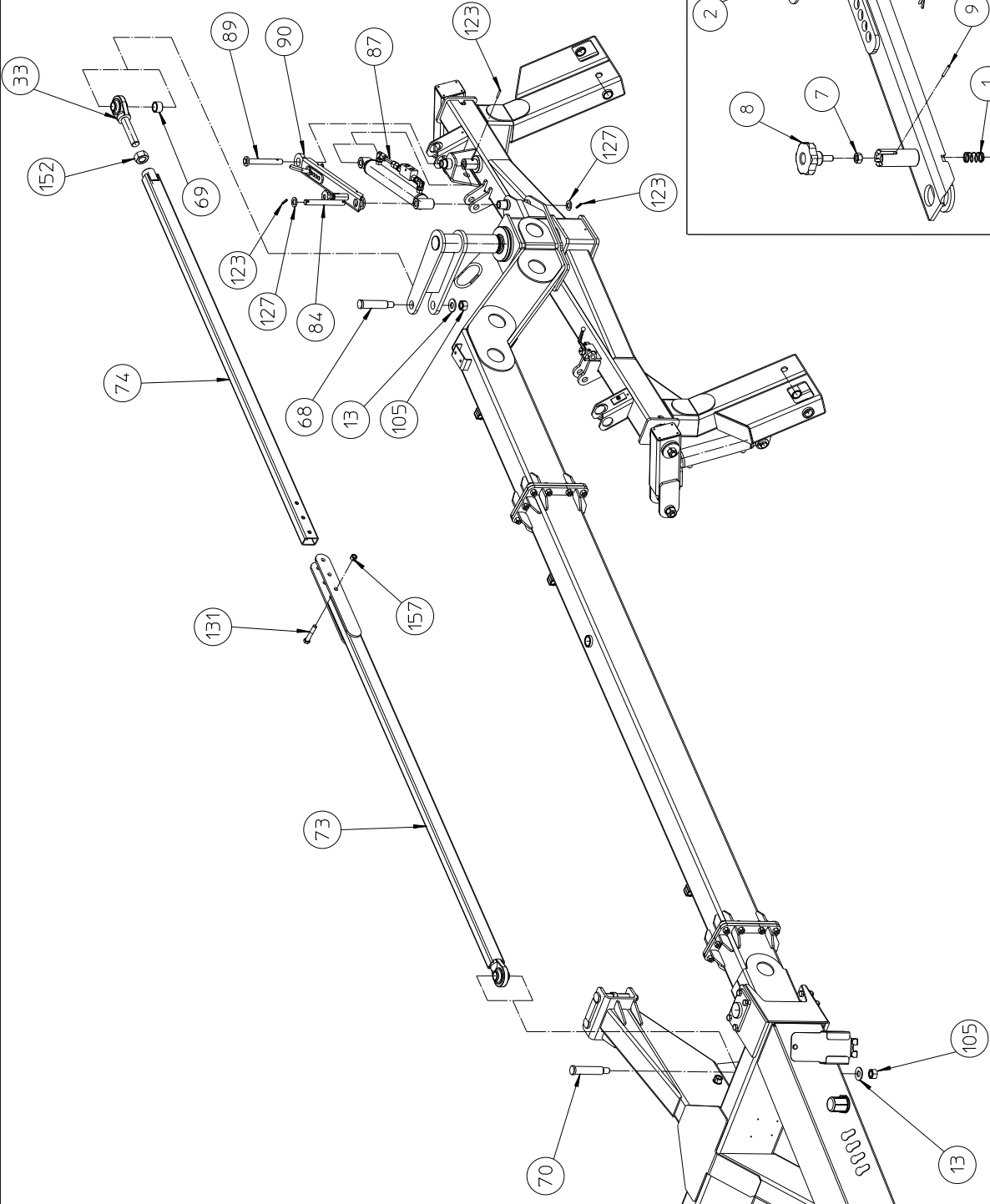

ANGLE SELECTOR 270.242

TIE RODS				
ITEM	PART N°	QTY	DESCRIPTION	NOTE
13	200.165	4	WASHER D 23/50 X 4	
33	270.053	2	TIE ROD TERMINAL	
68	270.181	2	LEVER PIN \varnothing 30X139	
69	270.187	2	LEVER SPACER	
70	270.190	2	DRAWBAR PIN \varnothing 30X154	
73	270.193	2	TIE ROD HEAD	
74	270.194	2	TIE ROD THREADED	
84	270.217	2	PIN \varnothing 20X173	
87	270.236	2	ANGLE CYLINDER	
89	270.238	2	HEAD PIN \varnothing 20X153	
90	270.242	2	ANGLE SELECTOR	
105	600.079	4	NUT CL M22 DIN 980 KL.8 ZN	
123	600.538	6	ELASTIC PIN D 6 X 35	
127	600.632	4	WASHER D 21 UNI 6592 ZN	
131	600.737	6	SCREW M14 X 80 UNI 5737 8.8 ZN	
152	620.253	2	NUT M30 UNI 5588 6S ZN	
157	620.441	6	NUT CL M14 DIN 980 KL.10 ZN	

ANGLE SELECTOR 270.242				
ITEM	PART N°	QTY	DESCRIPTION	NOTE
1	270.084	1	COMPRESSION SPRING	
2	270.239	1	PIN \varnothing 15X54	
3	270.240	1	TRANSPORT LOCKING PIN	
4	270.241	1	CASE	
5	270.250	1	SLIDE	
6	600.019	1	SPLIT PIN \varnothing 3	
7	600.037	1	NUT M8 UNI 5588 6S ZN	
8	600.592	1	HANDLE	
9	601.023	1	ELASTIC PIN \varnothing 3 X 24	

HYDRAULIC

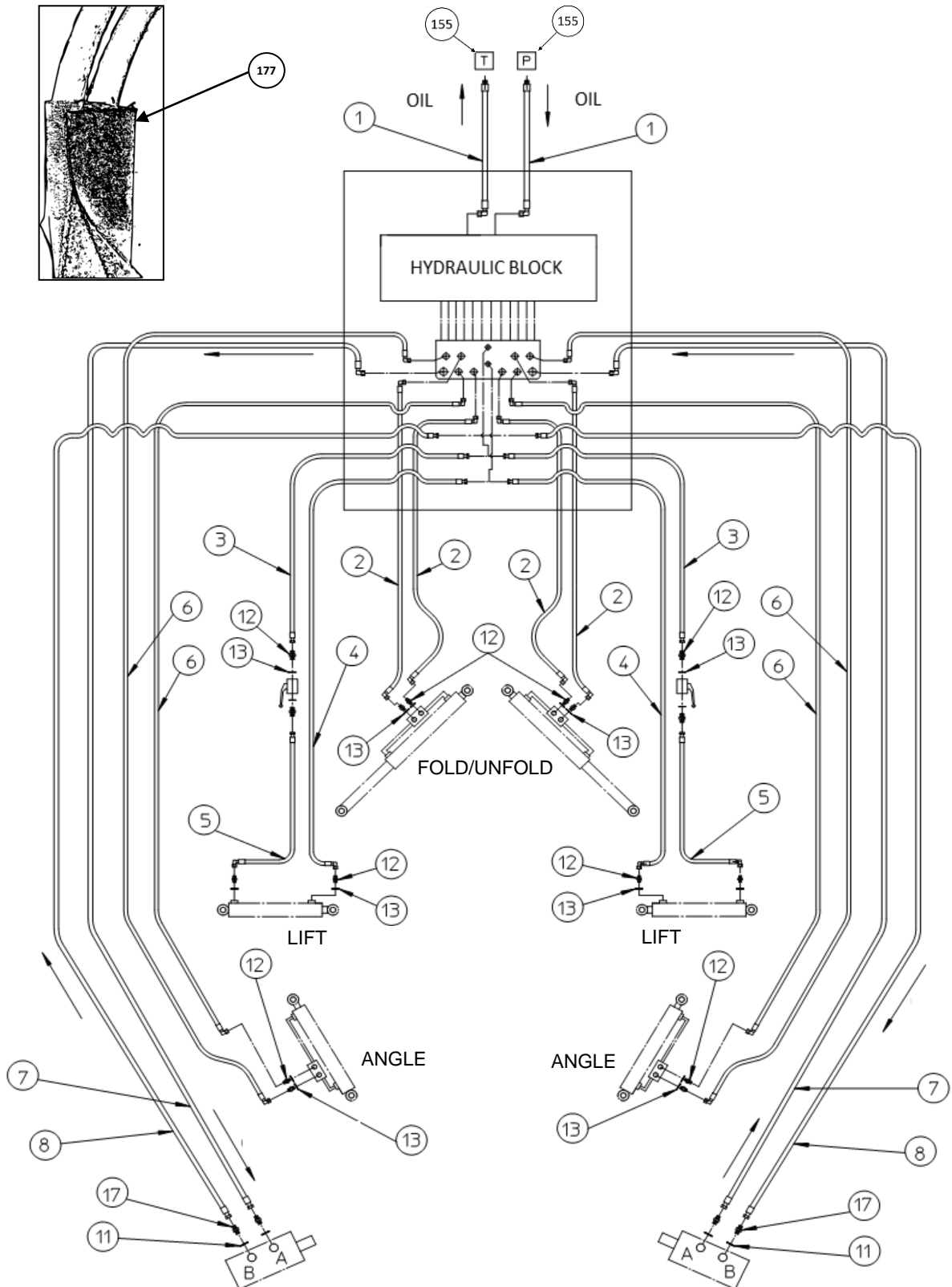
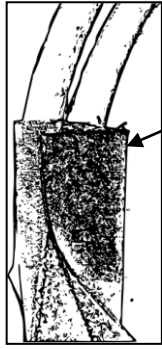

HYDRAULIC				
ITEM	PART N°	QTY	DESCRIPTION	NOTE
1	601.031	2	COND.SAE100R2ATx1/2 L. 3000 MD 1/2-14 NPTF F90 7/8 JIC	
2	601.077	4	COND.SAE100R2ATx3/8 L. 1400 F90 3/4 JIC - F90 3/4 JIC	
3	601.034	2	COND.SAE100R2ATx3/8 L. 5000 FD 3/4 JIC - FD 3/4 JIC	
4	601.035	2	COND.SAE100R2ATx3/8 L. 6200 FD 3/4 JIC - F90 3/4 JIC	
5	601.041	2	COND.SAE100R2ATx3/8 L. 1200 FD 3/4 JIC - F90 3/4 JIC	
6	601.037	4	COND.SAE100R2ATx3/8 L. 5200 F90 3/4 JIC - F90 3/4 JIC	
7	601.038	2	COND.SAE100R2ATx1/2 L. 6500 FD 7/8 JIC - F90 7/8 JIC	
8	601.039	2	COND.SAE100R2ATx1/2 L. 6400 FD 7/8 JIC - FD 7/8 JIC	
9	601.100	10	COND.SAE100R2ATx3/8 L. 600 F90 3/4 JIC - FD 3/4 JIC	
10	601.101	2	COND.SAE100R2ATx1/2 L. 600 F90 7/8 JIC - FD 7/8 JIC	
11	630.048	14	WASHER 1/2	
12	640.035	42	NIPPLES 3/8" GAS - 3/4" JIC	
13	620.452	50	WASHER 3/8	
14	632.083	6	FITTING MALE/FEMALE 3/8 GAS LG. EXAGON 22	
15	601.046	2	FITTING T M-M-M 3/4 JIC	
16	640.034	2	NIPPLES 3/8" GAS - 7/8" JIC	
17	601.043	12	NIPPLES 1/2" GAS - 7/8" JIC	
18	600.422	1	NIPPLES 1/2" GAS - 1/2" GAS	
155	620.329	2	RAPID COUPLING 1/2-14 NPTM	
177	270.277	16	SLEEVE FOR HOSES LG.50 CM	
UV	631.965	1	UNIDIRECTIONAL VALVE 1/2" 5 PSI	

HYDRAULIC

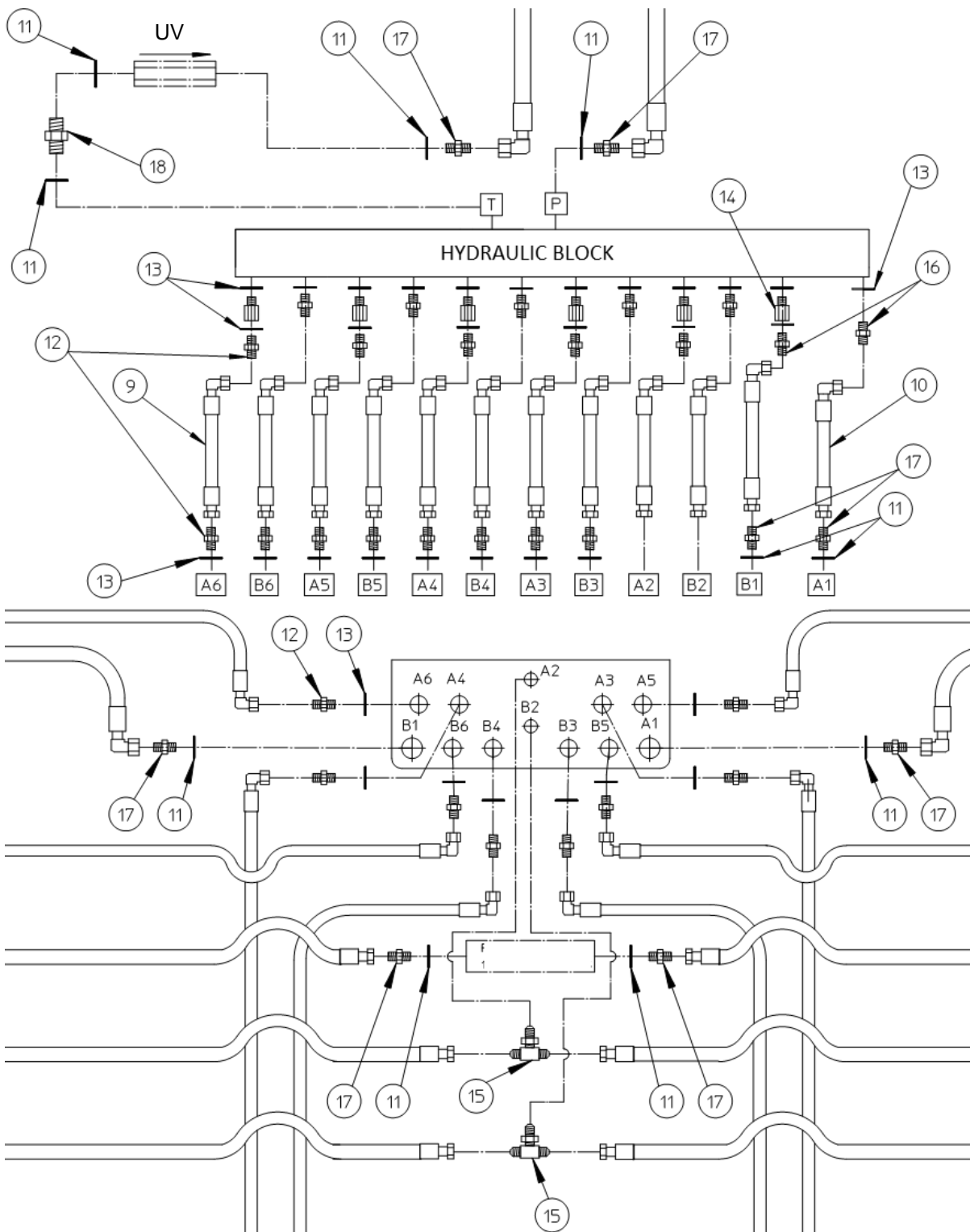

HYDRAULIC				
ITEM	PART N°	QTY	DESCRIPTION	NOTE
1	601.031	2	COND.SAE100R2ATx1/2 L. 3000 MD 1/2-14 NPTF F90 7/8 JIC	
2	601.077	4	COND.SAE100R2ATx3/8 L. 1400 F90 3/4 JIC - F90 3/4 JIC	
3	601.034	2	COND.SAE100R2ATx3/8 L. 5000 FD 3/4 JIC - FD 3/4 JIC	
4	601.035	2	COND.SAE100R2ATx3/8 L. 6200 FD 3/4 JIC - F90 3/4 JIC	
5	601.041	2	COND.SAE100R2ATx3/8 L. 1200 FD 3/4 JIC - F90 3/4 JIC	
6	601.037	4	COND.SAE100R2ATx3/8 L. 5200 F90 3/4 JIC - F90 3/4 JIC	
7	601.038	2	COND.SAE100R2ATx1/2 L. 6500 FD 7/8 JIC - F90 7/8 JIC	
8	601.039	2	COND.SAE100R2ATx1/2 L. 6400 FD 7/8 JIC - FD 7/8 JIC	
9	601.100	10	COND.SAE100R2ATx3/8 L. 600 F90 3/4 JIC - FD 3/4 JIC	
10	601.101	2	COND.SAE100R2ATx1/2 L. 600 F90 7/8 JIC - FD 7/8 JIC	
11	630.048	14	WASHER 1/2	
12	640.035	42	NIPPLES 3/8" GAS - 3/4" JIC	
13	620.452	50	WASHER 3/8	
14	632.083	6	FITTING MALE/FEMALE 3/8 GAS LG. EXAGON 22	
15	601.046	2	FITTING T M-M-M 3/4 JIC	
16	640.034	2	NIPPLES 3/8" GAS - 7/8" JIC	
17	601.043	12	NIPPLES 1/2" GAS - 7/8" JIC	
18	600.422	1	NIPPLES 1/2" GAS - 1/2" GAS	
177	270.277	16	SLEEVE FOR HOSES LG.50 CM	
UV	631.965	1	UNIDIRECTIONAL VALVE	

CYLINDERS

**SPARE PARTS KIT FOR
ANGLE CYLINDER
270.279**

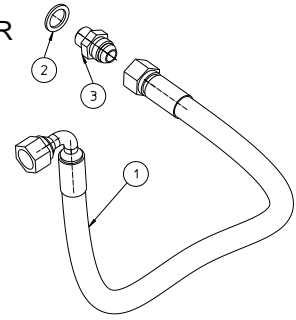

ANGLE CYLINDER COMPLETE 270.236

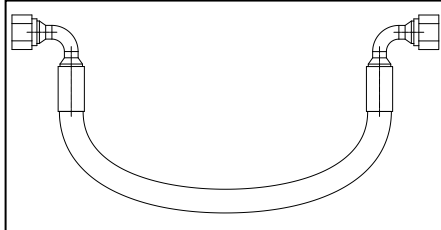
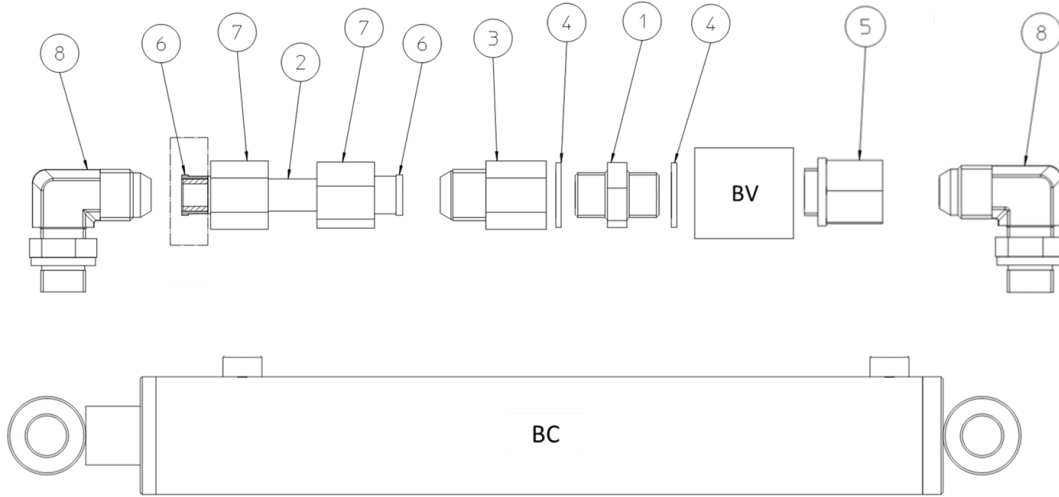

**SPARE PARTS KIT FOR
FOLD/UNFOLD CYLINDER
270.278**

FOLD/UNFOLD CYLINDER COMPLETE 270.255

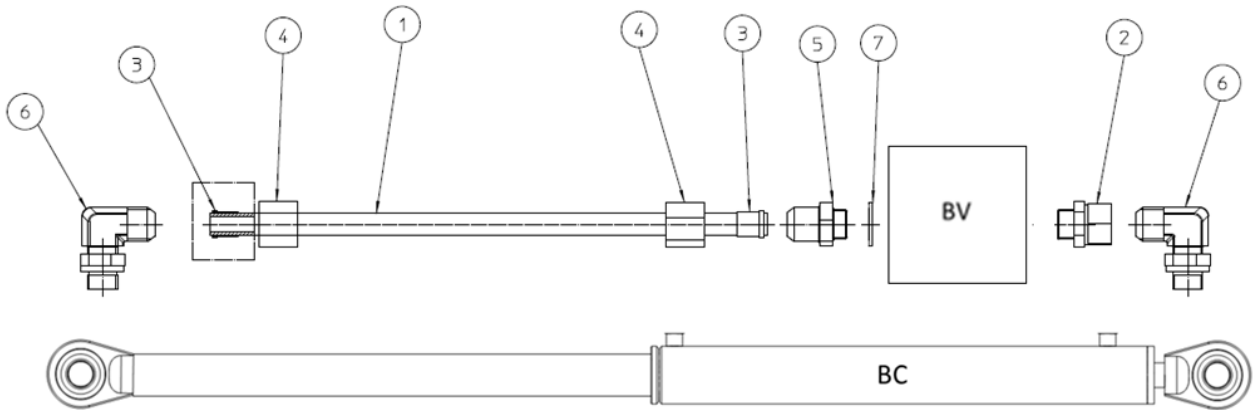

ANGLE CYLINDER COMPLETE 270.236				
ITEM	PART N°	QTY	DESCRIPTION	NOTE
1	601.142	1	NIPPLES 3/8-3/8 GAS WITH ORIFICE 0,5	
2	601.097	1	PIPE ø12	
3	601.098	1	FITTING M 3/4-16 JIC 37° - F 3/8 GAS	
4	620.452	2	WASHER 3/8	
5	630.633	1	FITTING MALE 3/8 GAS -FEMALE ¾ JIC SPINNING	
6	630.635	2	FITTING BUSH	
7	630.636	2	FITTING NUT	
8	630.639	2	FITTING 90 M 3/8 GAS - M 3/4 JIC	
BV	600.799	1	BLOCK VALVE 3/8	
BC	270.235	1	BARE CYLINDER	

SPARE PARTS KIT FOR ANGLE CYLINDER 270.279				
ITEM	PART N°	QTY	DESCRIPTION	NOTE
1	601.146	1	COND.EXCSAE100R16X3/8 L.600 F90 3/4 JIC - FD 3/4 JIC	
2	620.452	1	WASHER 3/8	
3	640.035	1	NIPPLES 3/8 GAS – ¾ JIC	

FOLD/UNFOLD CYLINDER COMPLETE 270.255				
ITEM	PART N°	QTY	DESCRIPTION	NOTE
1	601.099	1	PIPE ø12	
2	630.633	1	FITTING MALE 3/8 GAS -FEMALE ¾ JIC SPINNING	
3	630.635	2	FITTING BUSH	
4	630.636	2	FITTING NUT	
5	630.638	1	FITTING M 3/8 GAS - M 3/4	
6	630.639	2	FITTING 90 M 3/8 GAS - M 3/4 JIC	
7	620.452	1	WASHER 3/8	
BV	600.799	1	BLOCK VALVE 3/8	
BC		1	BARE CYLINDER	

SPARE PARTS KIT FOR FOLD/UNFOLD CYLINDER 270.278				
ITEM	PART N°	QTY	DESCRIPTION	NOTE
1	270.278	1	COND.EXCSAE100R16X3/8 L.600 F90 3/4 JIC – F90 3/4 JIC	

ELECTRICAL SYSTEM

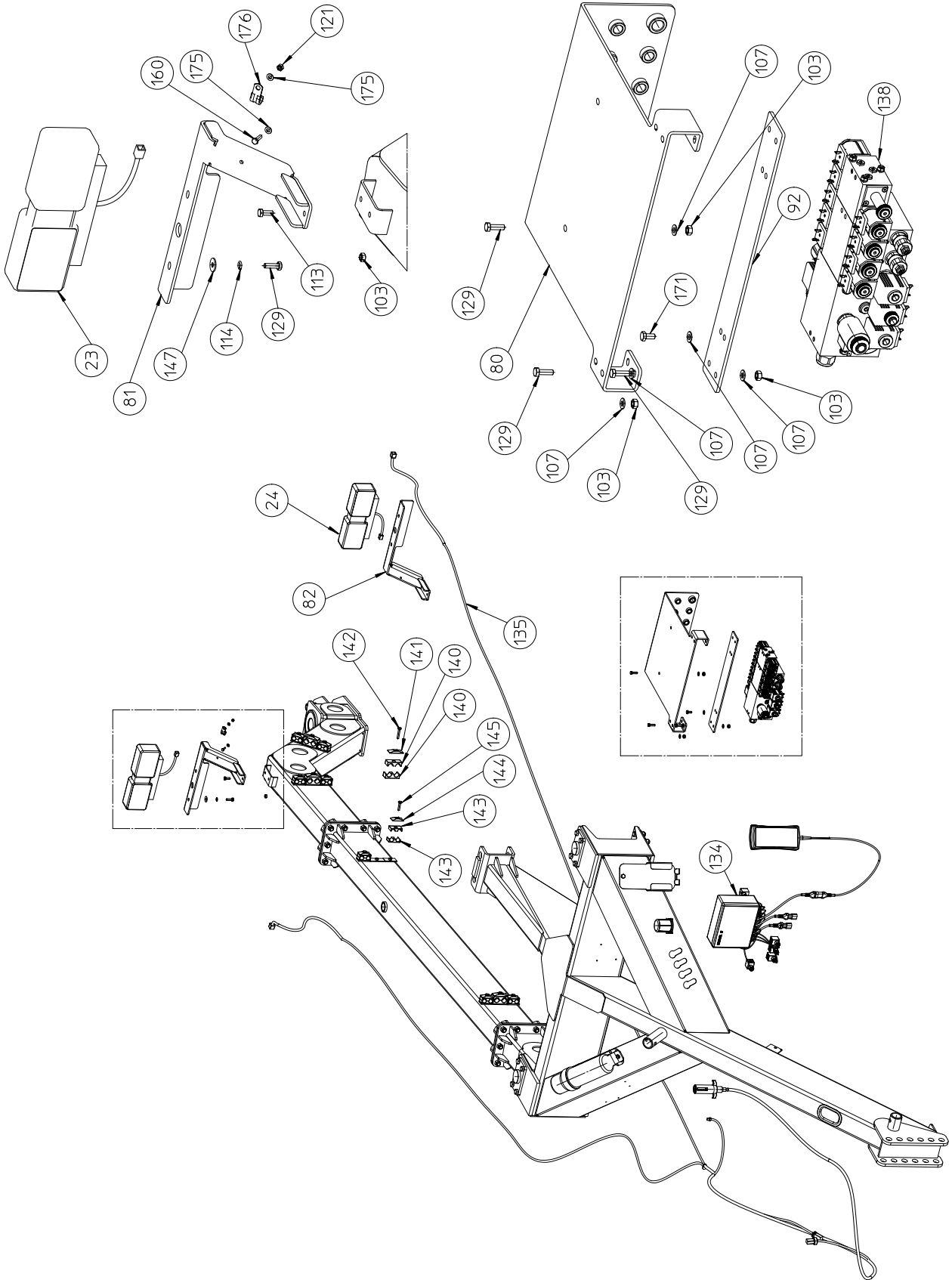

ELECTRICAL SYSTEM				
ITEM	PART N°	QTY	DESCRIPTION	NOTE
23	250.274	1	LIGHT RH	
24	250.275	1	LIGHT LH	
80	270.209	1	HYDRAULIC PANEL	
81	270.210	1	LIGHT BRACKET LH	
82	270.211	1	LIGHT BRACKET RH	
92	270.254	1	HYDRAULIC BLOCK SUPPORT	
103	600.076	14	NUT CL M 8 DIN 980 KL.8 ZN	
107	600.115	18	WASHER D 8,4 UNI 6592 ZN	
113	600.223	4	SCREW TE M 8 X 20 UNI 5739 8.8 ZN	
114	600.229	4	GROWER D 8,4 UNI 1751A ZN	
121	600.472	2	NUT CL M 6 DIN 980 KL.8 ZN	
129	600.702	14	SCREW TE M 8 X 25 UNI 5739 8.8 ZN	
134	601.018	1	KIT CMD RAKE	
135	601.019	1	WIRING HARNESS	
138	601.076	1	HYDRAULIC BLOCK	
140	610.041	16	HOSE HALF COLLAR 22 AD3 22-22 S	
141	610.043	8	HOSE COLLAR 22 PLATE ADPS 3	
142	610.044	8	SCREW M 8 X 45 UNI 5739 4.8 ZN	
143	610.162	36	HOSE HALF COLLAR 18 AD2 18-18 S	
144	610.164	18	HOSE COLLAR 18 PLATE ADPS 2	
145	610.165	18	SCREW M 8 X 35 UNI 5739 4.8 ZN	
147	610.185	4	WASHER D 9/24X2	
160	630.003	2	SCREW TE M 6 X 20 UNI 5739 8.8 ZN	
171	600.061	4	SCREW TE M 8 X 16 UNI 5739 8.8 ZN	
175	600.514	4	WASHER D 6,4 UNI 6592 ZN	
176	634.435	2	CLIP ø12	

ELECTRICAL SYSTEM

KIT CMD RAKE 601.018

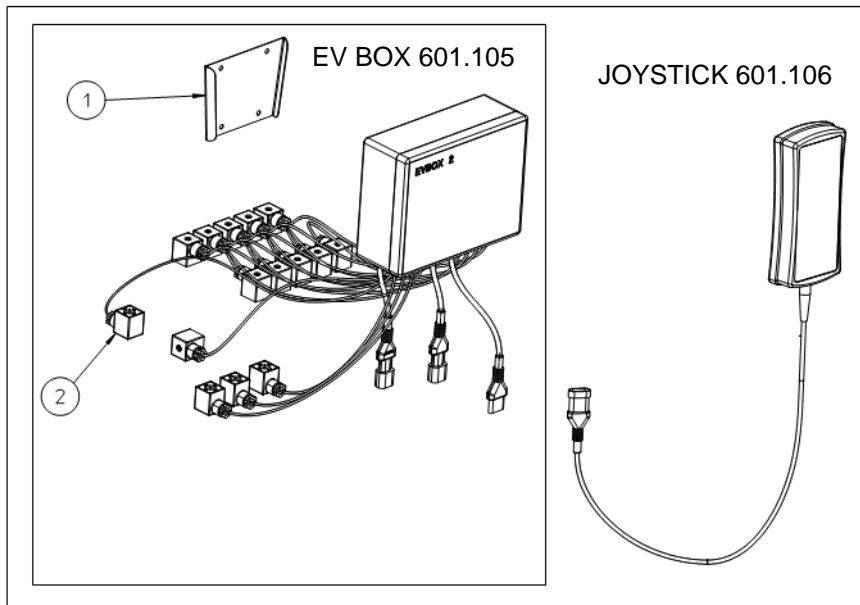

HYDRAULIC BLOCK 601.076

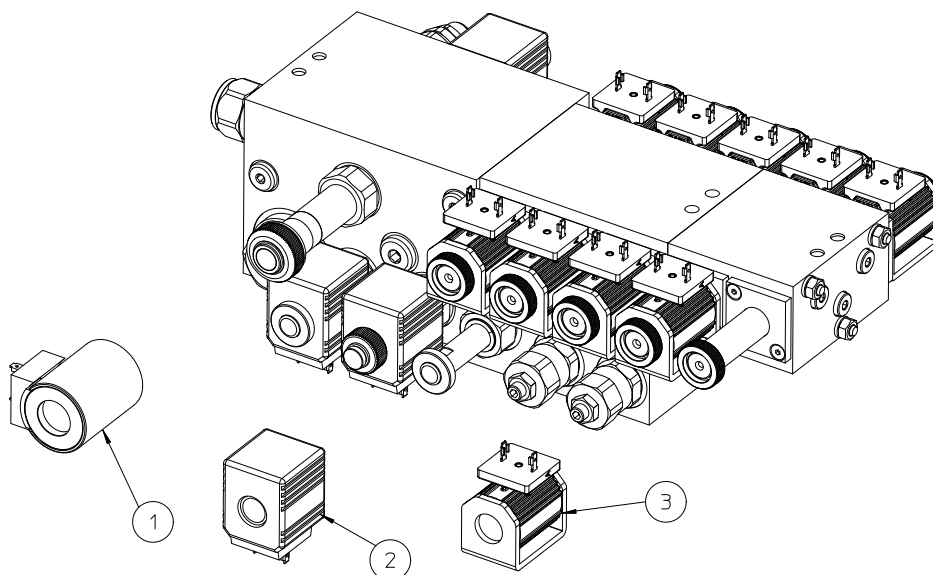

EV BOX 601.105				
ITEM	PART N°	QTY	DESCRIPTION	NOTE
1	270.265	1	METAL INTERFACE	
2	630.512	15	CONNECTOR WITH CABLE	

HYDRAULIC BLOCK 601.076				
ITEM	PART N°	QTY	DESCRIPTION	NOTE
1	601.127	1	PROPORTIONAL COIL 12V BR	
2	601.128	4	ON-OFF COIL 12V BR	
3	601.129	10	ON-OFF COIL 12V WITH SHIELD BR	

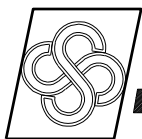

AGRICULTURAL MACHINERY
sitrex® SpA .

Zona Industriale-Viale Grecia, 8
06018 TRESTINA-(Perugia)-ITALY
Tel. +39.075.8540021-Telefax +39.075.8540523
e-mail: sitrex@sitrex.it www.sitrex.com

