

# TAVOLE RICAMBI • SPARE PARTS TABLES • PLANCHES DES PIÈCES DÉTACHÉES • LAMINAS REPUESTOS • ERSATZTEILTAFELN

## ITALIANO - TAVOLE RICAMBI

Tav. 1	Telaio .....	78
Tav. 2	Terzo punto .....	80
Tav. 3	Gruppo scatola completo.....	82
Tav. 4	Trasmissione laterale ad ingranaggi.....	84
Tav. 5	Rotore.....	86
Tav. 6	Regolazione cofano a molla.....	88
Tav. 7	Regolazione rullo .....	90
Tav. 8	Rullo dentato .....	92
Tav. 9	Rullo gabbia.....	94
Tav. 10	Protezioni CE .....	96

## ENGLISH - SPARE PART TABLES

Tab. 1	Frame .....	78
Tab. 2	Three-point hitch .....	80
Tab. 3	Gear box.....	82
Tab. 4	Geared side transmission.....	84
Tab. 5	Rotor .....	86
Tab. 6	Spring hood adjustment.....	88
Tab. 7	Roller adjustment .....	90
Tab. 8	Sprocket roller .....	92
Tab. 9	Cage roller.....	94
Tab. 10	CE Protections.....	96

## FRANÇAIS - PLANCHES DES PIÈCES DÉTACHÉES

Pl. 1	Châssis.....	78
Pl. 2	Bâti a trois points .....	80
Pl. 3	Boîte de vitesse .....	82
Pl. 4	Transmission latérale à engranages .....	84
Pl. 5	Rotor .....	86
Pl. 6	Réglage du capot à ressort.....	88
Pl. 7	Réglage du rouleau .....	90
Pl. 8	Rouleau hérisson.....	92
Pl. 9	Rouleau à cage .....	94
Pl. 10	Protection CE .....	96

## DEUTSCH - ERSATZTEILTAFELN

Taf. 1	Gestel .....	78
Taf. 2	Gerätedreieck, geräteseitig .....	80
Taf. 3	Multiplikator .....	82
Taf. 4	Seitlicher Kettenantrieb.....	84
Taf. 5	Rotor .....	86
Taf. 6	Haube der Maschine und Hintere rechen .....	88
Taf. 7	Radeinstellung .....	90
Taf. 8	Stachelwalze.....	92
Taf. 9	Käfigwalze.....	94
Taf. 10	CE schutzvorrichtung.....	96

## ESPAÑOL - LAMINAS REPUESTOS

Lám. 1	Bastidor.....	78
Lám. 2	Armazón de tres puntos.....	80
Lám. 3	Grupo multiplicador.....	82
Lám. 4	Transmisión lateral de engranajes.....	84
Lám. 5	Rotor .....	86
Lám. 6	Regulación protección de muelle .....	88
Lám. 7	Regulación rodillo .....	90
Lám. 8	Rodillo dentado .....	92
Lám. 9	Rodillo de jaula .....	94
Lám. 10	Protección CE.....	96

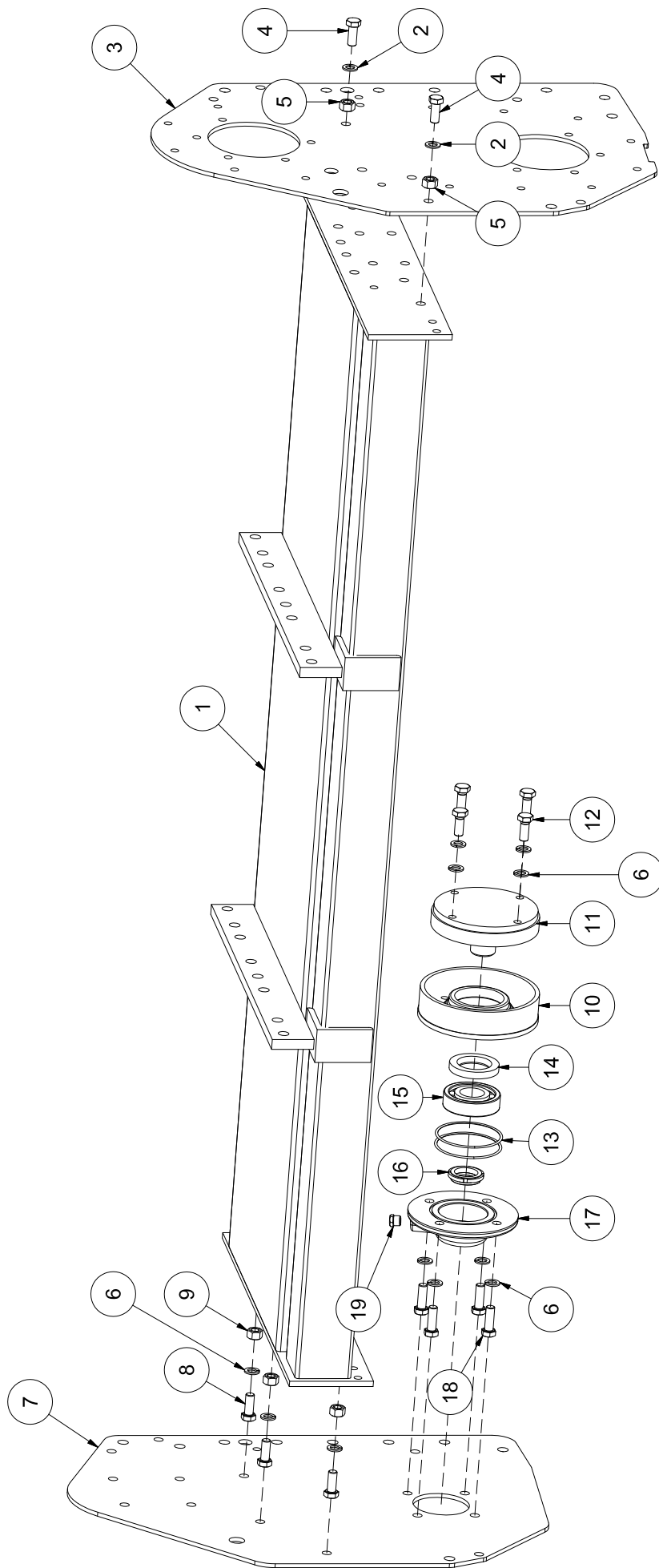

Tav. 1

POS.	CODICE	DESCRIZIONE	QTA
1		TELAIO	1
		VERS. 155	
		VERS. 180	
		VERS. 205	
		VERS. 230	
2	0001067	GROWER Ø12 C72 DIN 128	3
3	3177755	FONDO CARTER VERS. CATENA	1
4	0002186	VITE TE M12x30 CL.8.8 UNI 5739-65	3
5	0001042	DADO M12 CL.6S UNI 5587	3
6	0001067	GROWER Ø12 C72 DIN 128	11
7	5201406	FIANCO DESTRO	1
8	0002186	VITE TE M12x30 CL.8.8 UNI 5739-65	3
9	0001042	DADO M12 CL.6S UNI 5587	3
10	5500141	SUPPORTO ROTORE DESTRO	1
11	5500139	PERNO ROTORE DESTRO	1
12	0074094	VITE TE M12x30 CL.8.8 PF UNI 5740-65	4
13	8064390	GUARNIZIONE O-RING 153 UNI 3350	2
14	8064389	PARAOILIO 45.70.10	1
15	0001061	CUSCINETTO 6307 (35.80.21)	1
16	0037098	GHIERA M35x1,5 GUK AUTOBLOCCANTE	1
17	3177305	COPERCHIELLA ESTERNA DESTRA	1
18	0001043	VITE TE M12x35 CL.8.8 UNI 5739-65	4
19	0094188	TAPPO OLIO M14x1,5 ZINCATO DIN 909	1

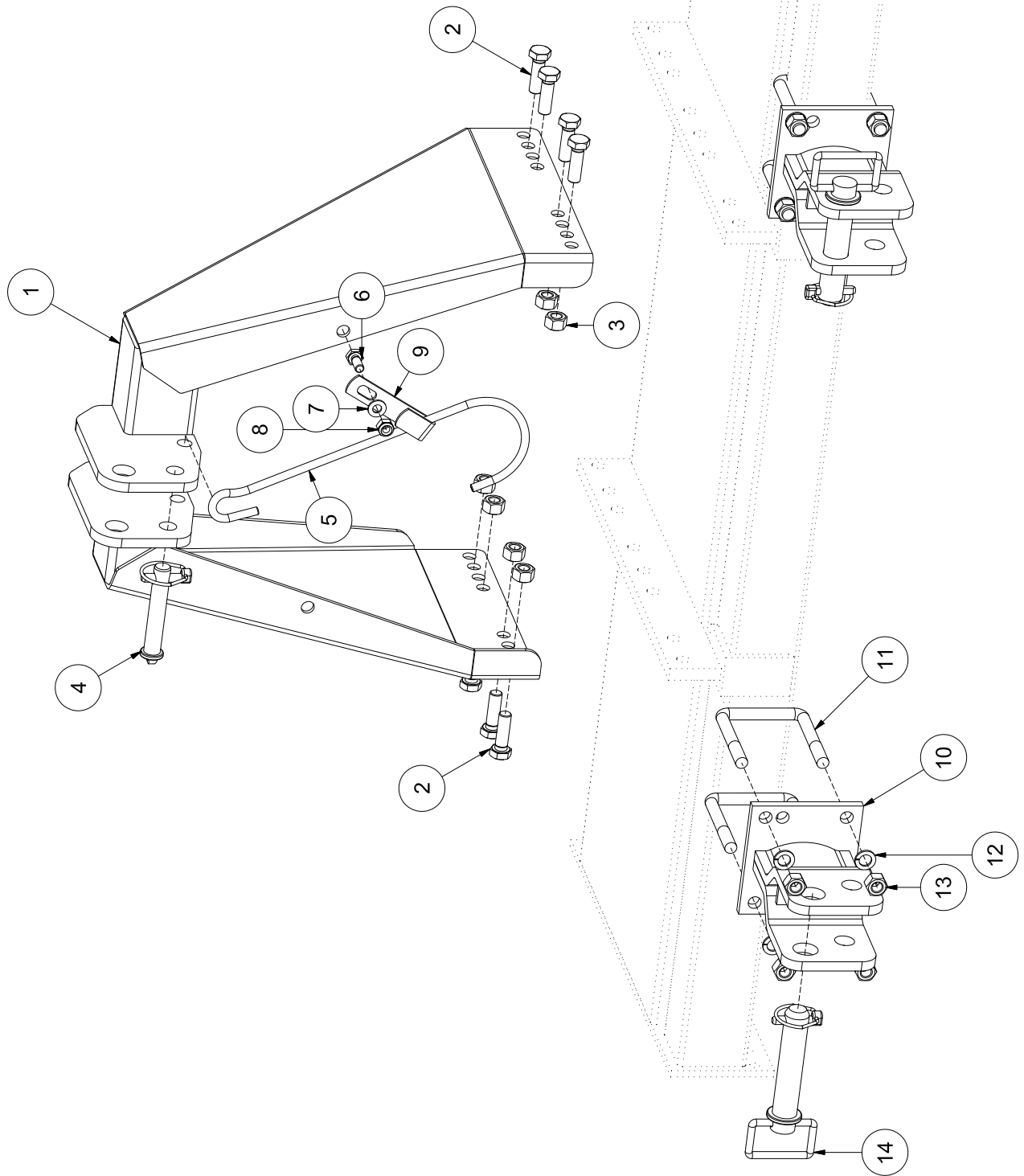

Tav. 2

## Tav. 2

POS.	CODICE	DESCRIZIONE	QTA
1	E1300006	TERZO PUNTO	1
2	0077536	VITE TE M14x45 CL.8.8 PF ZINCATA UNI 5740-65	8
3	8064948	DADO M14 CL.8 PF ZINCATO AUTOFRENANTE	8
4		SPINA TERZO PUNTO	
	8040306	CAT. I	1
	8064376	CAT. II	1
5	0060085	GANCIO SOSTEGNO CARDANO	1
6	0033176	VITE TE M10x25 CL.8.8 ZINCATA UNI 5739-65	5
7	0002034	RONDELLA PIANA Ø10 ZINCATA UNI 6592	1
8	0014106	DADO M10 ZINCATO AUTOBLOCCANTE ALTO DIN 982	1
9	Z0100206	ATTACCO PER GANCIO SOSTEGNO CARDANO	1
10	0038335	ATTACCO TRATTORE	2
11	0077259	CAVALLOTTO M14	4
12	0001020	GROWER Ø14 ZINCATA C72 DIN 128	8
13	0001019	DADO M14 CL.65 ZINCATO UNI 5587	8
14		SPINA ATTACCO TRATTORE	
	8064472	CAT. I	2
	8064385	CAT. II	2

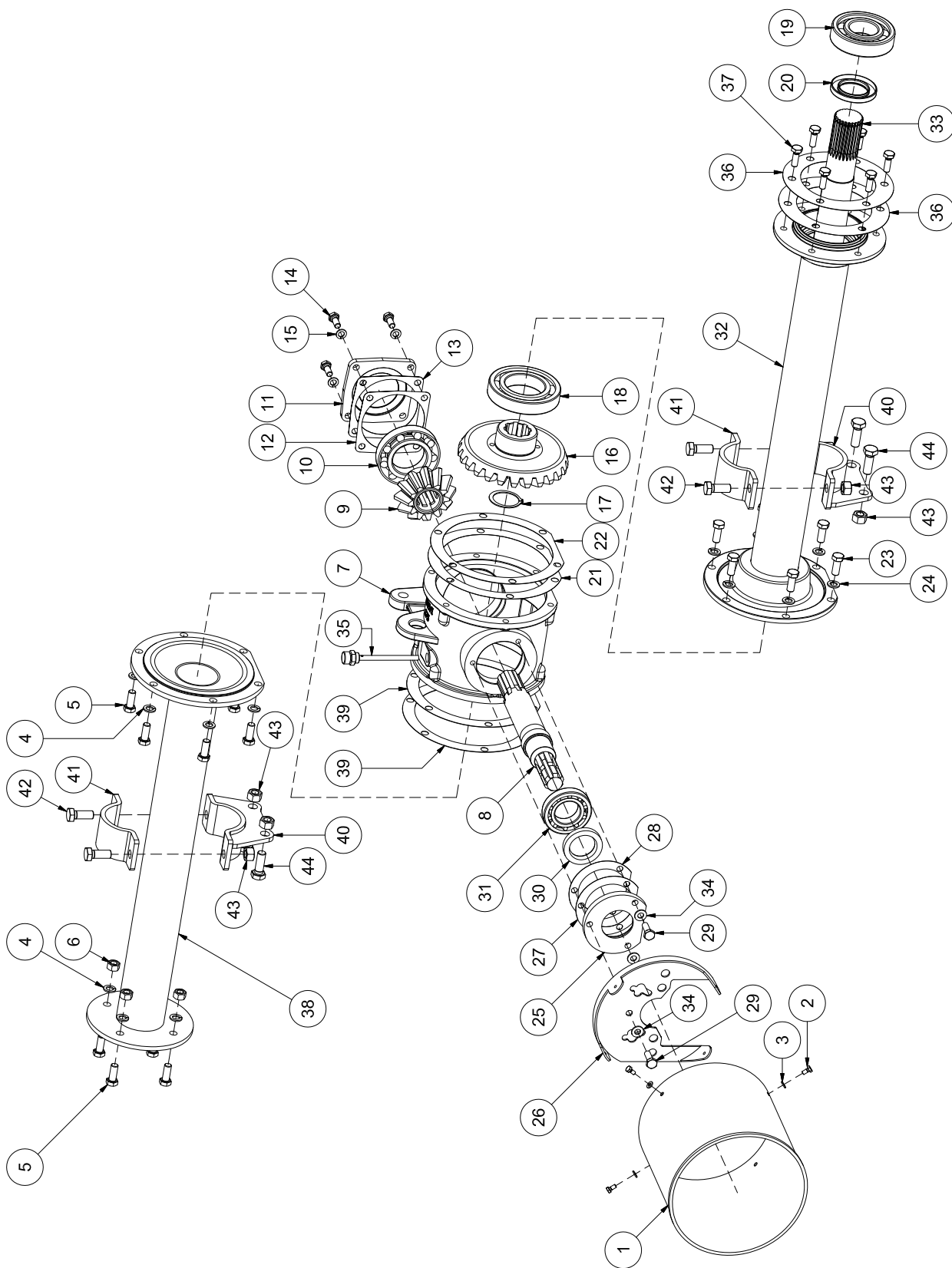

Tav. 3

## Tav. 3

POS.	CODICE	DESCRIZIONE	QTA
1	0049301	PROTEZIONE PTO	1
2	0091385	VITE TE M6x12 CL.8.8 ZINCATA UNI 5739-65	4
3	0050166	RONDELLA PIANA Ø6 ZINCATA UNI 6592	4
4	0001067	GROWER Ø12 C72 DIN 128	10
5	0002186	VITE TE M12x30 CL.8.8 UNI 5739-65	10
6	0001042	DADO M12 CL.65 UNI 5587	4
7	0002151	FUSIONE SCATOLA INGRANAGGI	1
8	3178973	ALBERO P.D.F.	1
9	0025163	COPIA CONICA (PIGNONE Z=12)	1
10	0002164	CUSCINETTO 30212	1
11	0025172	COPERCHIELLA	1
12	0025173	GUARNIZIONE PIGNONE Sp.0,2	1
13	0125173	GUARNIZIONE PIGNONE Sp.0,5	1
14	0001241	VITE TE M10x25 CL.8.8 UNI 5739-65	4
15	0001011	GROWER Ø10 C72 DIN 128	4
16	8200627	COPIA CONICA (CORONA Z=25)	1
17	0002110	SEGER Ø48 ESTERNO DIN 471	1
18	0002137	CUSCINETTO 6214	1
19	0002072	CUSCINETTO 6310	1
20	0001155	PARAOLIO 50.80.10	1
21	0002141	GUARNIZIONE Sp.2/10	1
22	0102141	GUARNIZIONE Sp.5/10	1
23	0002186	VITE TE M12x30 CL.8.8 UNI 5739-65	6
24	0001067	GROWER Ø12 C72 DIN 128	6
25	3178958	COPERCHIELLA	1
26	0049307	PORTA PROTEZIONE CARDANO	1
27	0025180	GUARNIZIONE Sp.2/10	1
28	0125180	GUARNIZIONE Sp.5/10	1
29	0001008	VITE TE M10x30 CL.8.8 UNI 5739-65	3
30	0013199	PARAOLIO 45.68.10	1
31	0002168	CUSCINETTO 30209	1
32		TUBO TRASVERSALE	1
		SENZA CAMBIO	
	3177770	VERS. 155	
	Z1020013	VERS. 180	
	Z1023013	VERS. 205	
	3177771	VERS. 230	
		CON CAMBIO	
	3177766	VERS. 155	
	Z1018013	VERS. 180	
	Z1020013	VERS. 205	
	Z1023013	VERS. 230	

POS.	CODICE	DESCRIZIONE	QTA
33		ALBERO TRASVERSALE	1
		SENZA CAMBIO	
	3177765	VERS. 155	
	0313151	VERS. 180	
	0413151	VERS. 205	
	0613151	VERS. 230	
		CON CAMBIO	
	3177764	VERS. 155	
	0213151	VERS. 180	
	0313151	VERS. 205	
	0413151	VERS. 230	
34	0002034	RONDELLA PIANA Ø10 ZINCATA UNI 6592	3
35	0058344	TAPPO LIVELLO OLIO L=115	1
36	0013095	GUARNIZIONE	2
37	0001008	VITE TE M10x30 CL.8.8 UNI 5739-65	6
38		TUBO DI SOSTEGNO	1
		VERS. 155	
	5500622	VERS. 180	
	5500623	VERS. 205	
	5500624	VERS. 230	
	Z1023010		
39	0102141	GUARNIZIONE Sp.5/10	2
40	Z6000009	SEMICOLLARE INFERIORE	2
41	Z6000008	SEMICOLLARE SUPERIORE	2
42	8065067	VITE TE M14x35 CL.8.8 PF UNI 5740-65	4
43	8064948	DADO M14 CL.8 PF AUTOFRENANTE	8
44	0077535	VITE TE M14x40 CL.8.8 PF UNI 5740-65	4

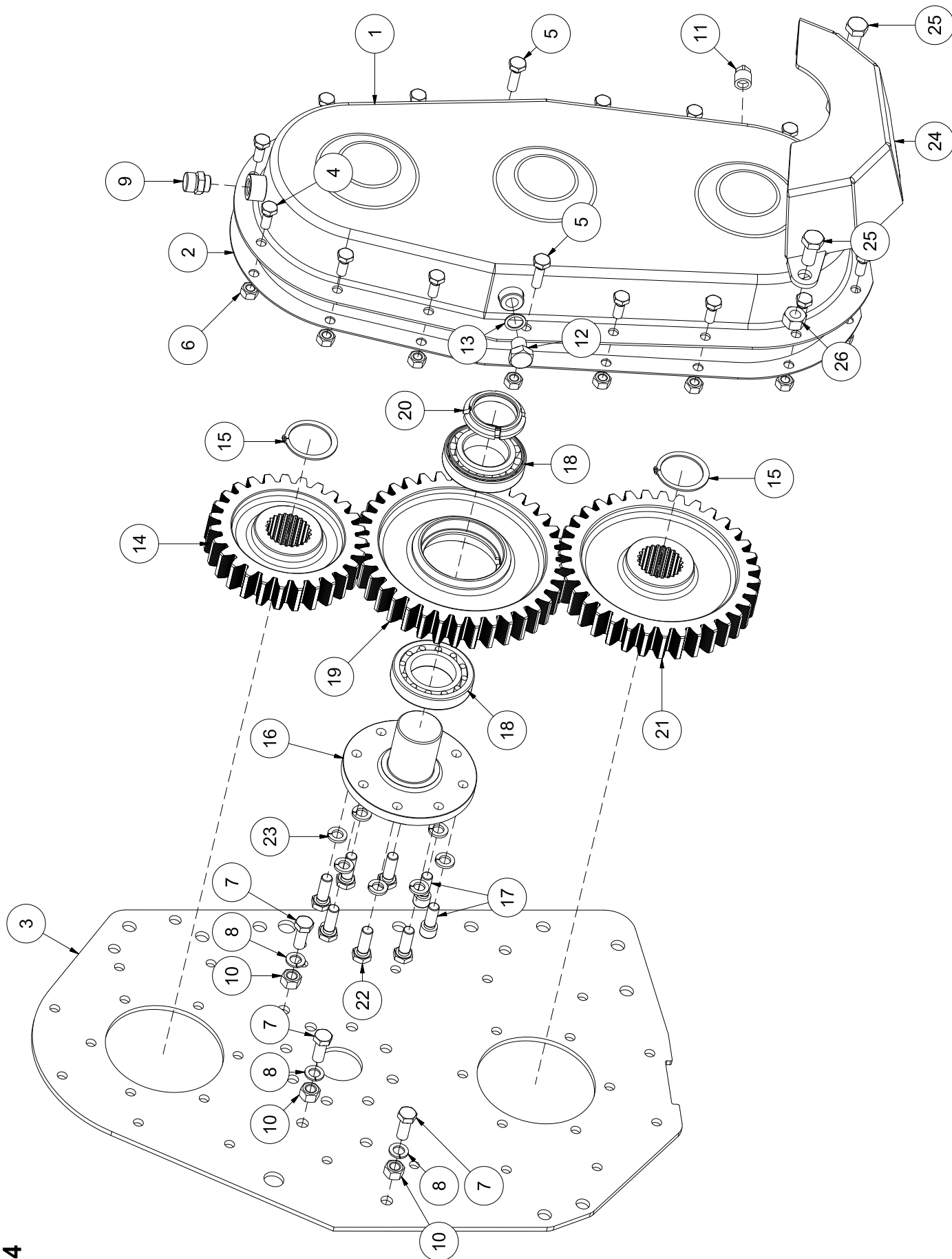

Tav. 4



## Tav. 4

POS.	CODICE	DESCRIZIONE	QTÀ
1	0073031	COPERCHIO CARTER	1
2	0073036	GUARNIZIONE	1
3	3178060	FONDO CARTER TRASMISSIONE INGRANAGGI	1
4	0001241	VITE TE M10x25 CL.8.8 UNI 5739-65	14
5	0001009	VITE TE M10x35 CL.8.8 UNI 5739-65	2
6	0030156	DADO M10 AUTOFRENANTE	16
7	0002186	VITE TE M12x30 CL.8.8 UNI 5739-65	3
8	0001067	GROWER Ø12 C72 DIN 128	3
9	8064435	TAPPO SFIATO	1
10	0001042	DADO M12 CL.6S UNI 5587	3
11	0064227	TAPPO TROPICALIZZATO	1
12	0066406	VITE M16x20 NERA UNI 5739	1
13	0041866	RONDELLA RAME 3/8"	1
14	3178057	INGRANAGGIO SUPERIORE Z=27	1
15	0025115	SEGER Ø50 ESTERNO DIN 472	2
16	3178061	PERNO INGRANAGGIO OZIOSO	1
17	8000008	VITE TCEI M12x30 CL.8.8 UNI 5931	2
18	0004539	CUSCINETTO 30210	2
19	3178058	INGRANAGGIO OZIOSO Z=37	1
20	0091121	GHIERA GUK M50x1,5	1
21	3178059	INGRANAGGIO INFERIORE Z=35	1
22	8065132	VITE TE M12x35 CL.8.8 PF UNI 5740	6
23	0061110	GROWER Ø12 FIAT 10188 12,4x4x3	8
24	Z1000045	PROTEZIONE CARTER	1
25	0032618	VITE TE M14x30 CL.8.8 UNI 5739-65	2
26	0030358	DADO M14 AUTOFRENANTE	2

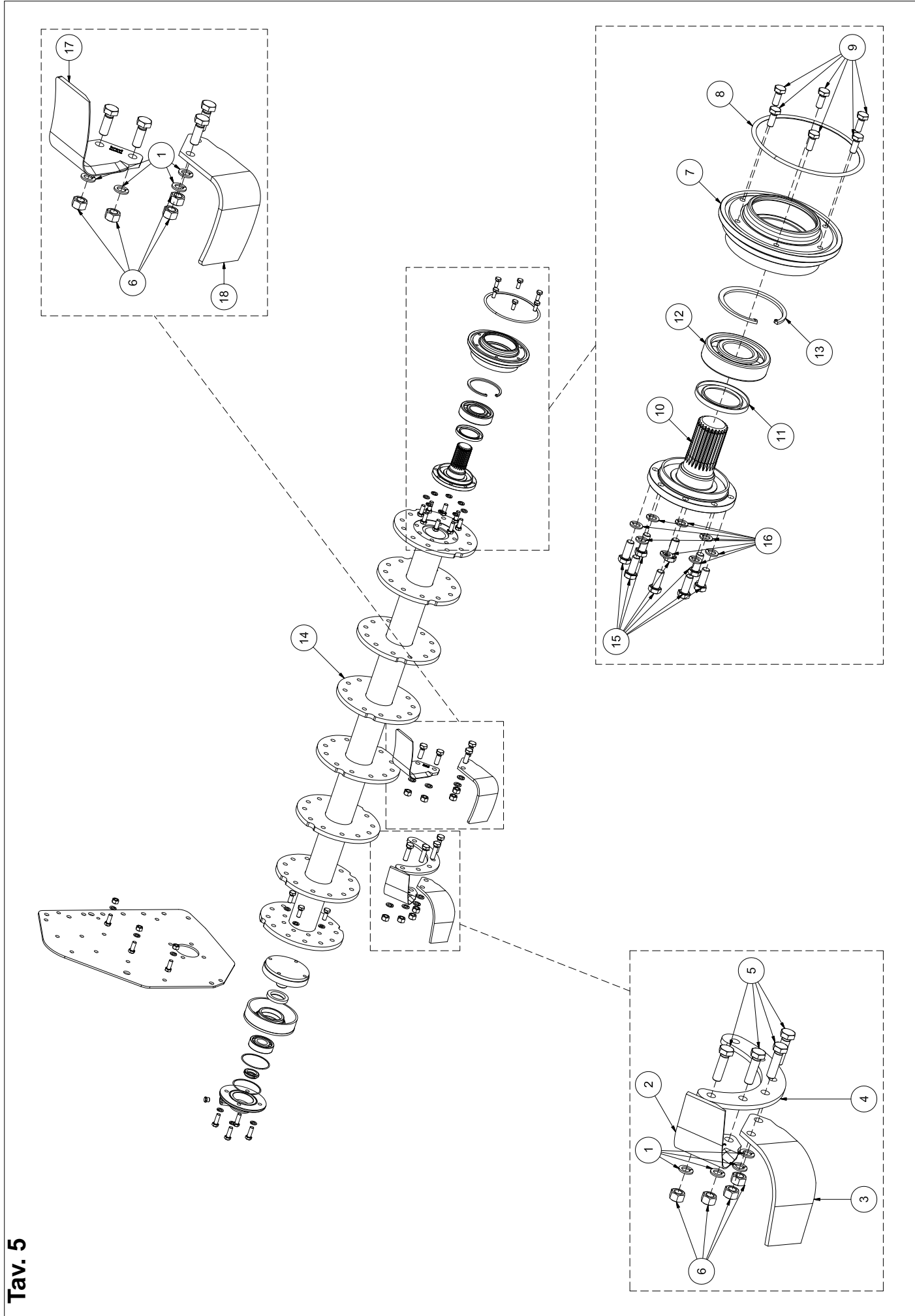

Tav. 5

## Tav. 5

POS.	CODICE	DESCRIZIONE	QTÀ
1	0001020	GROWER Ø14 C72 ZINCATA DIN 128	
		VERS. 155	84
		VERS. 180	96
		VERS. 205	108
		VERS. 230	120
2	0064811S	ZAPPA AD ELICA SINISTRA	
		VERS. 155	21
		VERS. 180	24
		VERS. 205	27
		VERS. 230	30
3	0064811D	ZAPPA AD ELICA DESTRA	
		VERS. 155	21
		VERS. 180	24
		VERS. 205	27
		VERS. 230	30
4	0073670	RINFORZO FLANGIA	
		VERS. 155	12
		VERS. 180	14
		VERS. 205	16
		VERS. 230	18
5		VITI FISSA ZAPPETTE	
		SENZA RINFORZO FLANGIA	
	0003062	VITE TE M14x40 CL.12.9 PF ZINCATA UNI 5740	
		VERS. 155	84
		VERS. 180	96
		VERS. 205	108
		VERS. 230	120
		CON RINFORZO FLANGIA	
	0017105	VITE TE M14x50 CL.12.9 PF ZINCATA UNI 5740	
		VERS. 155	84
		VERS. 180	96
		VERS. 205	108
		VERS. 230	120

POS.	CODICE	DESCRIZIONE	QTÀ
6	0003064	DADO M14 CL.6S PF ZINCATO UNI 5587	
		VERS. 155	84
		VERS. 180	96
		VERS. 205	108
		VERS. 230	120
7	5500621	SUPPORTO ROTORE SINISTRO	1
8	0073159	GUARNIZIONE O-RING UNI 6700	1
9	0077532	VITE TE M10x25 CL.8.8 PF ZINCATA UNI 5740-65	6
10	5500620	PERNO ROTORE SINISTRO	1
11	0073152	PARAOLIO 60.90.8 BASL	1
12	0002072	CUSCINETTO 6310	1
13	0002073	SEEGER INTERNO Ø110 UNI 7437	1
14		ROTORE PASSO 225mm	1
	Z8015022	VERS. 155	
	Z8018022	VERS. 180	
	Z8020022	VERS. 205	
	Z8023022	VERS. 230	
15	0077110	VITE M12x30 CL.10.9 ZINCATA UNI 5739	8
16	0001067	GROWER Ø12 C72 DIN 128	8
17	0064818D	ZAPPETTA A SQUADRA DESTRA	
		VERS. 155	21
		VERS. 180	24
		VERS. 205	27
		VERS. 230	30
18	0064818S	ZAPPETTA A SQUADRA SINISTRA	
		VERS. 155	21
		VERS. 180	24
		VERS. 205	27
		VERS. 230	30

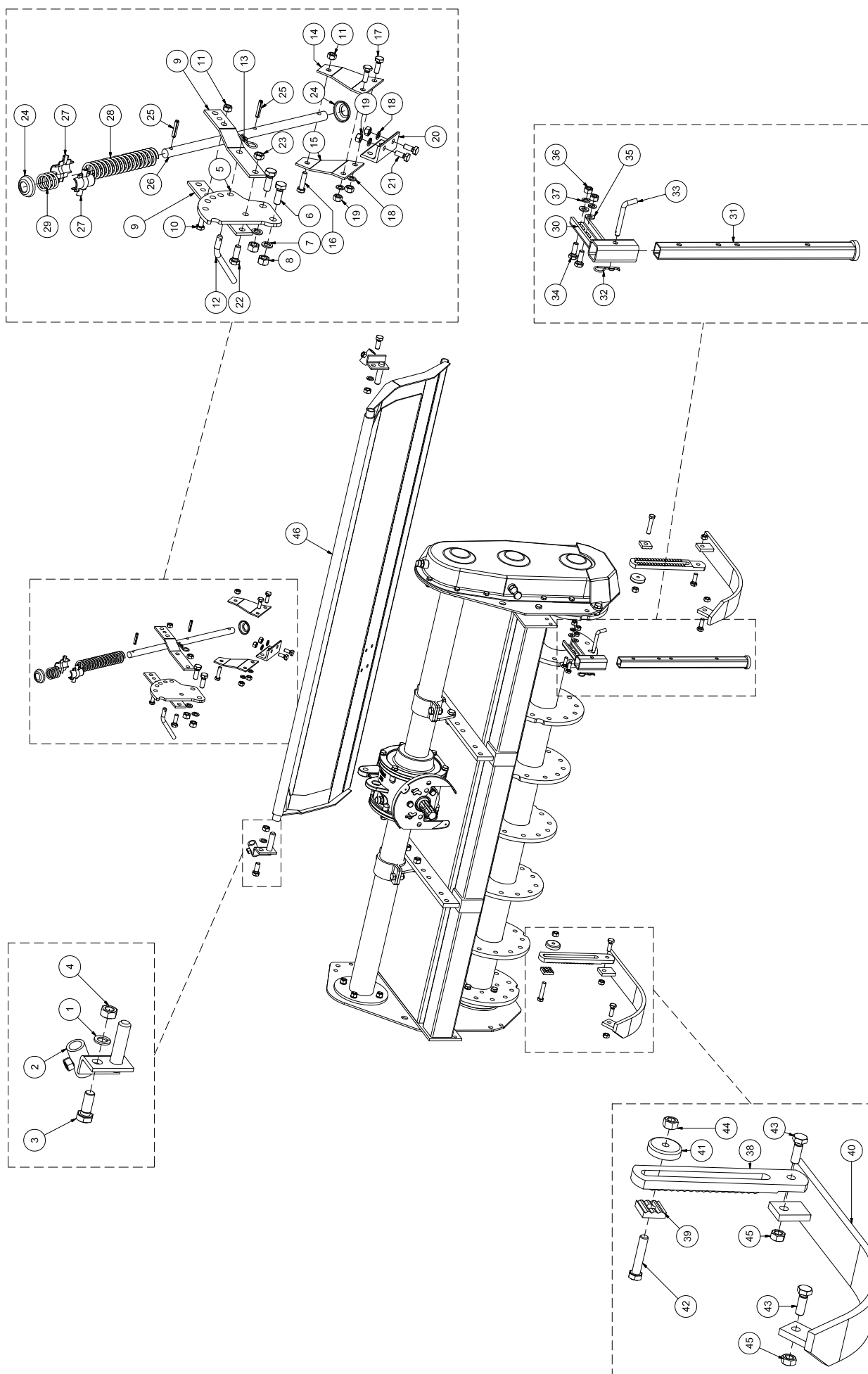

**Tav. 6**

POS.	CODICE	DESCRIZIONE	QTA
1	0001020	GROWER Ø14 C72 ZINCATA DIN 128	2
2		SUPPORTO PROTEZIONE	1
	5500176	DESTRO	
	5500175	SINISTRO	
3	0001526	VITE TE M14x35 CL.8.8 ZINCATA UNI 5739-65	2
4	0001177	DADO M14 CL.65 ZINCATA UNI 5588	2
5	0017351	PIASTRA DI REGOLAZIONE	1
6	0074232	VITE TE M14x40 CL.8.8 ZINCATA UNI 5739-65	2
7	0001020	GROWER Ø14 C72 ZINCATA DIN 128	2
8	0001019	DADO M14 CL.65 ZINCATA UNI 5587	2
9	0017359	LAMA	2
10	0215207	VITE TE M10x70 CL.8.8 ZINCATA UNI 5737-65	1
11	0030156	DADO M10 AUTOFRENANTE	2
12	0017357	SPINA ZINCATA	1
13	0015240	COPIGLIA A MOLLA Ø3 AGR1-2	1
14	0117371	ATTACCO DESTRO ASTA	1
15	0217371	ATTACCO SINISTRO ASTA	1
16	0038614	VITE TE M10x40 CL.8.8 ZINCATA UNI 5739-65	1
17	0001278	VITE TE M10x30 CL.8.8 ZINCATA UNI 5739-65	2
18	0001280	GROWER Ø10 C72 ZINCATA DIN 128	4
19	0001279	DADO M10 CL.65 ZINCATO UNI 5587	4
20	0035986	ANGOLARE ATTACCO ASTA COFANO	1
21	0033176	VITE TE M10x25 CL.8.8 ZINCATA UNI 5739-65	2
22	0007255	VITE TE M12x35 CL.8.8 ZINCATA UNI 5739-65	1
23	0030064	DADO M12 CL.8 AUTOFRENANTE	1
24	0017365	COPERCHIELLA ARRESTO MOLLA	2
25	0073562	SPINA ELASTICA Ø8x40 ZINCATA DIN 1481	2
26		ASTA	1
	0017364	COFANO STRISCIANTE	
	0040458	COFANO MOBILE	
27	0015244	CROCIERA GUIDA ASTA ZINCATA	2
28	0017369	MOLLA LUNGA	1
29	0017370	MOLLA COFANO CORTA	1
30	0022022	ATTACCO PER PIEDINO	1
31	0022018	PIEDINO	1
32	0015240	COPIGLIA A MOLLA Ø3 AGR1-2	1
33	0042255	SPINA	1
34	0001278	VITE TE M10x30 CL.8.8 ZINCATA UNI 5739-65	2
35	0002034	RONDELLA PIANA Ø10 ZINCATA UNI 6592	2
36	0001279	DADO M10 CL.65 ZINCATO UNI 5587	2
37	0001280	GROWER Ø10 C72 ZINCATA DIN 128	2

POS.	CODICE	DESCRIZIONE	QTA
38	0037054	REGISTRO SLITTA	2
39	0037057	FERMO	2
40		SLITTA	
	0137051	DESTRA	1
	0237051	SINISTRA	1
41	0030066	RONDELLA FILETTATA M12	2
42	0021257	VITE TE M12x60 CL.8.8 UNI 5739	2
43	0007255	VITE TE M12x35 CL.8.8 ZINCATA UNI 5739-65	4
44	0003038	DADO M12 CL.65 ZINCATO UNI 5587	2
45	0030064	DADO M12 CL.8 AUTOFRENANTE	4
46		COFANO POSTERIORE	1
		COFANO STRISCIANTE	
	Z8015023	VERS. 155	
	Z8018023	VERS. 180	
	Z8020023	VERS. 205	
	Z8023023	VERS. 230	
		COFANO MOBILE	
	5500125	VERS. 155	
	5500128	VERS. 180	
	5500314	VERS. 205	
	5500629	VERS. 230	

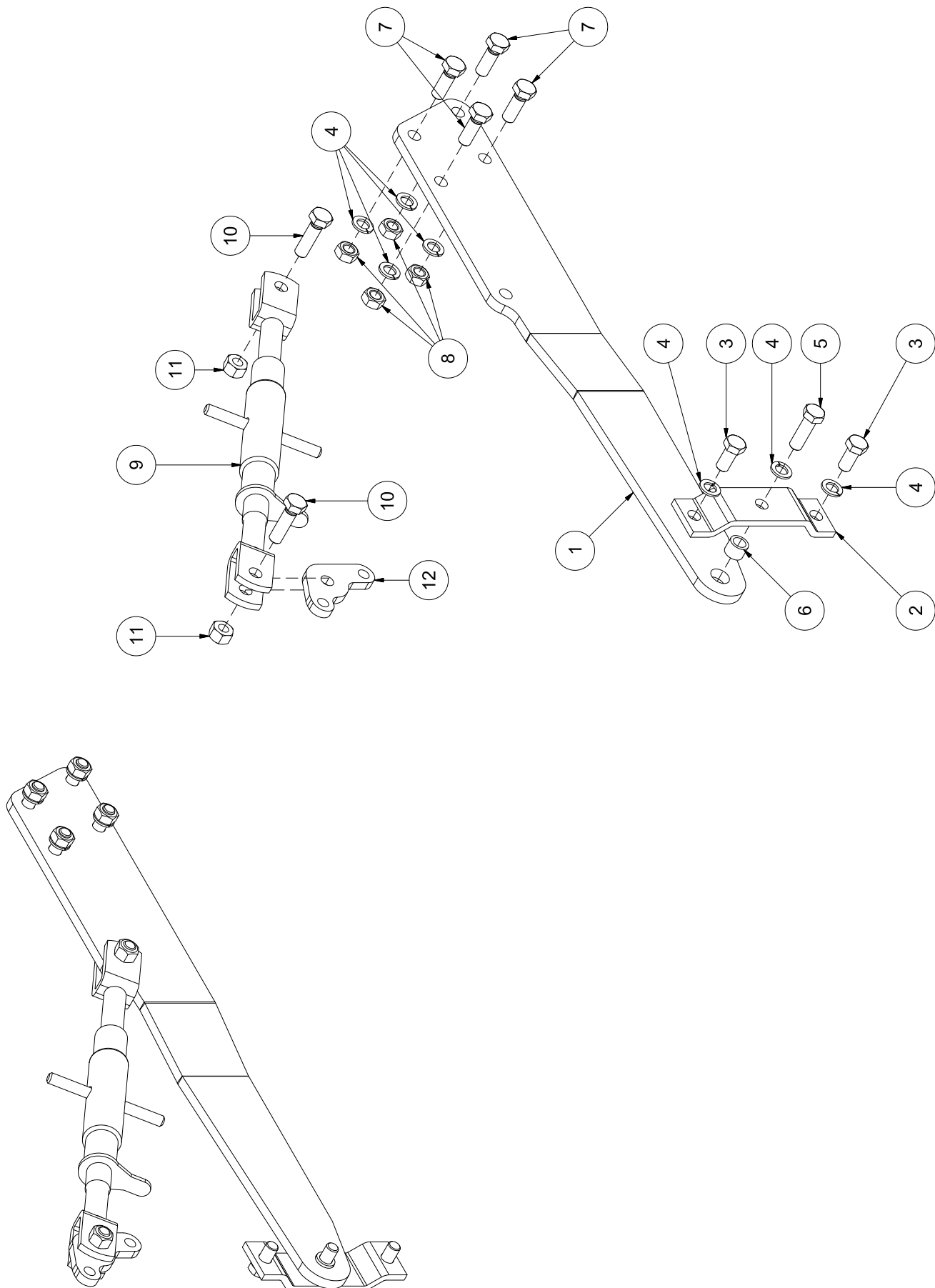

Tav. 7

## Tav. 7

POS.	CODICE	DESCRIZIONE	QTÀ
1		BRACCIO SUPPORTO RULLO	
	3178111	SINISTRO	1
	3177777	DESTRO	1
2	0070505	PIASTRA ATTACCO BRACCIO RULLO	2
3	0032618	VITE TE M14x30 CL.8.8 ZINCATA UNI 5739-65	4
4	0001020	GROWER Ø14 C72 ZINCATA DIN 128	14
5	0037349	VITE M14x45 CL.8.8 ZINCATA UNI 5739-65	2
6	0073414	DISTANZIALE	2
7	0074232	VITE TE M14x40 CL.8.8 ZINCATA UNI 5739-65	8
8	0001177	DADO M14 CL.6S ZINCATO UNI 5588	8
9	0077481	TENDITORE	2
10	0029317	VITE TE M14x50 CL.8.8 ZINCATA UNI 5739-65	4
11	0030358	DADO M14 AUTOFRENANTE	4
12	3179084	RINFORZO PER TENDITORE	2

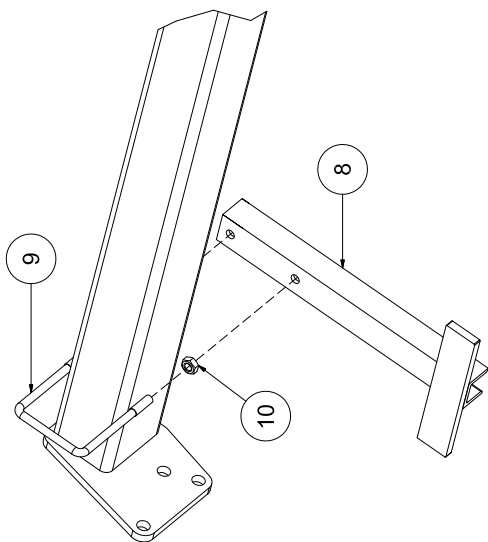
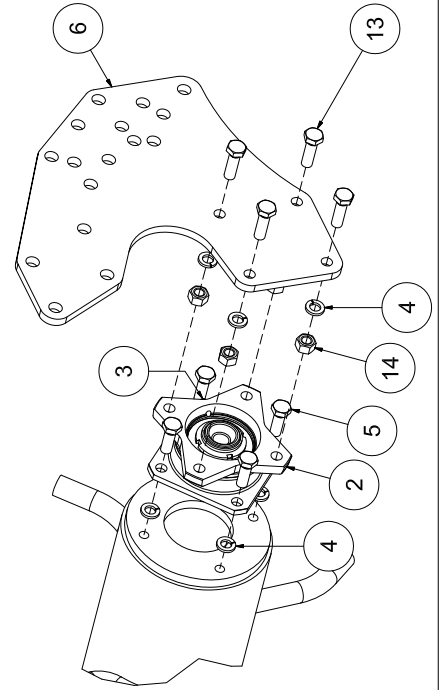
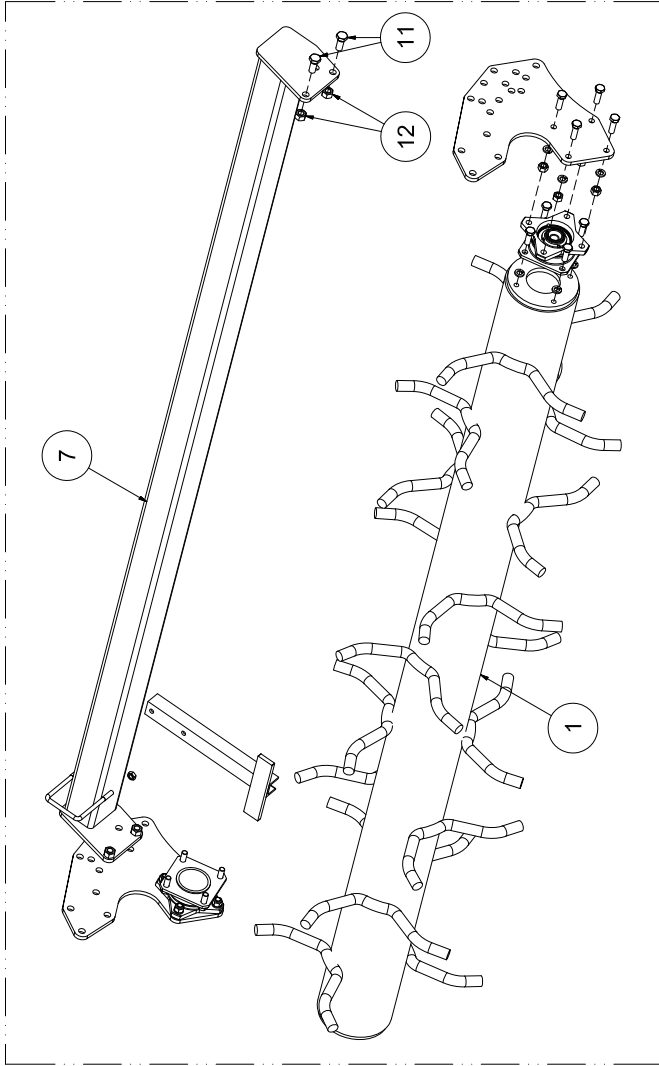

**Tav. 8**



## Tav. 8

POS.	CODICE	DESCRIZIONE	QTA'
1		RULLO DENTATO Ø477	1
	5500101	VERS. 155	
	5500102	VERS. 180	
	5500097	VERS. 205	
	5500098	VERS. 230	
2	8200063	GRUPPO SUPPORTO RULLO	2
3	0001065	INGRASSATORE M10x1	2
4	0001077	GROWER Ø12 C72 ZINCATA DIN 128	16
5	0032942	VITE TE M12x25 CL.8.8 PF ZINCATA UNI 5740-65	8
6	R0100002	PIASTRA SUPPORTO RULLO	2
7		PORTA RASCHIETTI	1
	R0116011	VERS. 155	
	R0118011	VERS. 180	
	R0220002	VERS. 205	
	R0223002	VERS. 230	
8		NETTARULLO	
	5500134	VERS. 155	5
	5500134	VERS. 180	6
	5500134	VERS. 205	7
	5500134	VERS. 230	8
9		CAVALLOTTO	
	0077450	VERS. 155	5
	0077450	VERS. 180	6
	R0200004	VERS. 205	7
	R0200004	VERS. 230	8
10		DADO FISSA CAVALLOTTO	
	0001279	VERS. 155	10
	0001279	VERS. 180	12
	0090182	VERS. 205	14
	0090182	VERS. 230	16
11	0001526	VITE TE M14x35 CL.8.8 ZINCATA UNI 5739-65	4
12	0030358	DADO M14 CL.8 ZINCATA AUTOFRENANTE	4
13	0027236	VITE TE M12x40 CL.8.8 ZINCATA UNI 5737-65	8
14	0003038	DADO M12 CL.6S ZINCATO UNI 5587	8

KIT RULLO COMPLETO

8200128 KIT RULLO DENTATO VERS. 155 Ø477

8200126 KIT RULLO DENTATO VERS. 180 Ø477

8200125 KIT RULLO DENTATO VERS. 205 Ø477

8200124 KIT RULLO DENTATO VERS. 230 Ø477

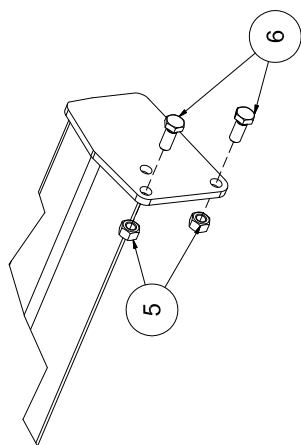
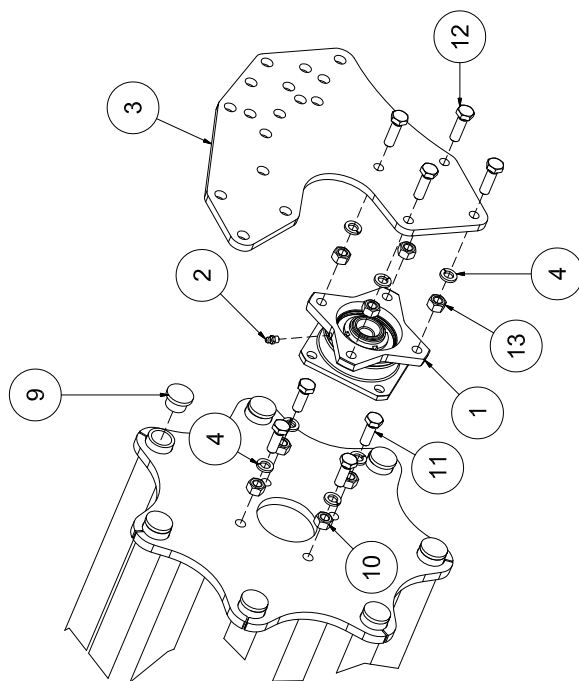
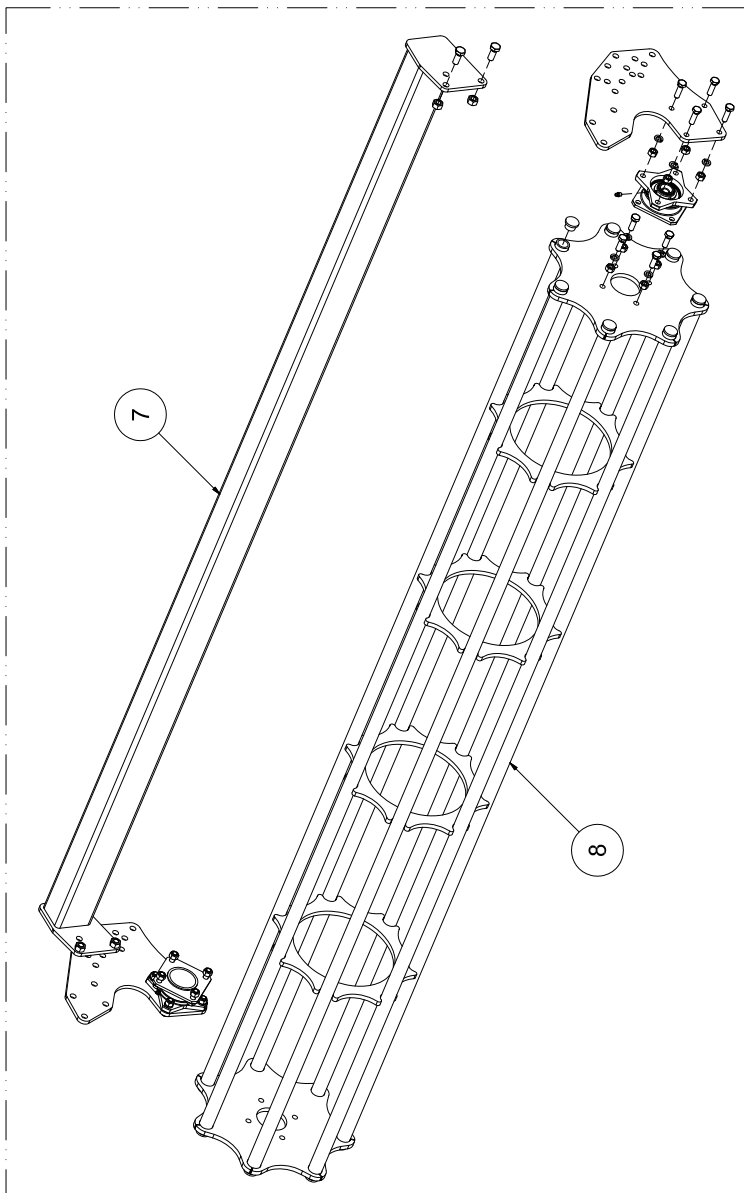

Tav. 9

## Tav. 9

POS.	CODICE	DESCRIZIONE	QTA'
1	8200063	GRUPPO SUPPORTO RULLO	2
2	0001065	INGRASSATORE M10x1	2
3	R0100002	PIASTRA SUPPORTO RULLO	2
4	0001077	GROWER Ø12 C72 ZINCATA DIN 128	16
5	0030358	DADO M14 CL.8 AUTOFRENANTE	4
6	0001526	VITE TE M14x35 CL.8.8 ZINCATA UNI 5739-65	4
7		PORTA RASCHIETTI	1
	R0116011	VERS. 155	
	R0118011	VERS. 180	
	R0220002	VERS. 205	
	R0223002	VERS. 230	
8		RULLO A GABBIA Ø405	1
	5501708	VERS. 155	
	5500651	VERS. 180	
	5500650	VERS. 205	
	5501710	VERS. 230	
9	3178211	TAPPO Ø22	14
10	0003038	DADO M12 CL.6S ZINCATO UNI 5587	8
11	0007255	VITE TE M12x35 CL.8.8 ZINCATA UNI 5739-65	8
12	0027236	VITE TE M12x40 CL.8.8 ZINCATA UNI 5737-65	8
13	0003038	DADO M12 CL.6S ZINCATO UNI 5587	8
KIT RULLO COMPLETO			
	8201105	KIT RULLO GABBIA V. 155 Ø405	
	8201107	KIT RULLO GABBIA V. 180 Ø405	
	8200351	KIT RULLO GABBIA V. 205 Ø405	
	8200352	KIT RULLO GABBIA V. 230 Ø405	

Tav. 10

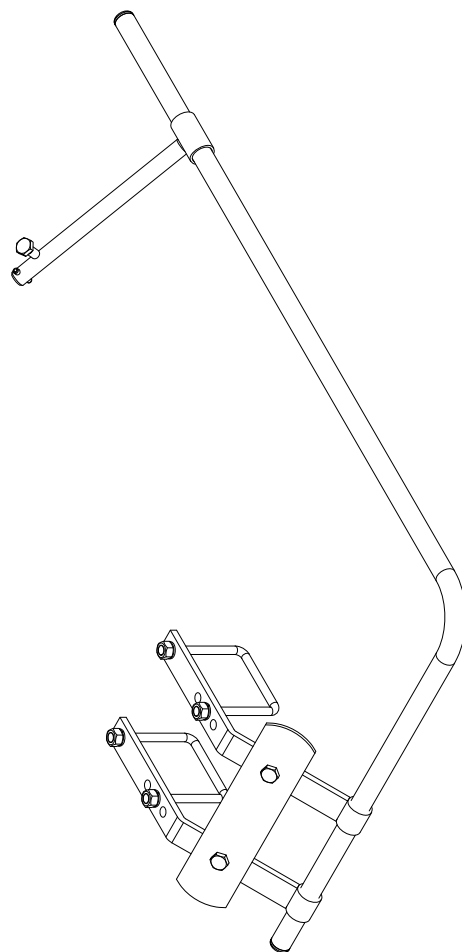
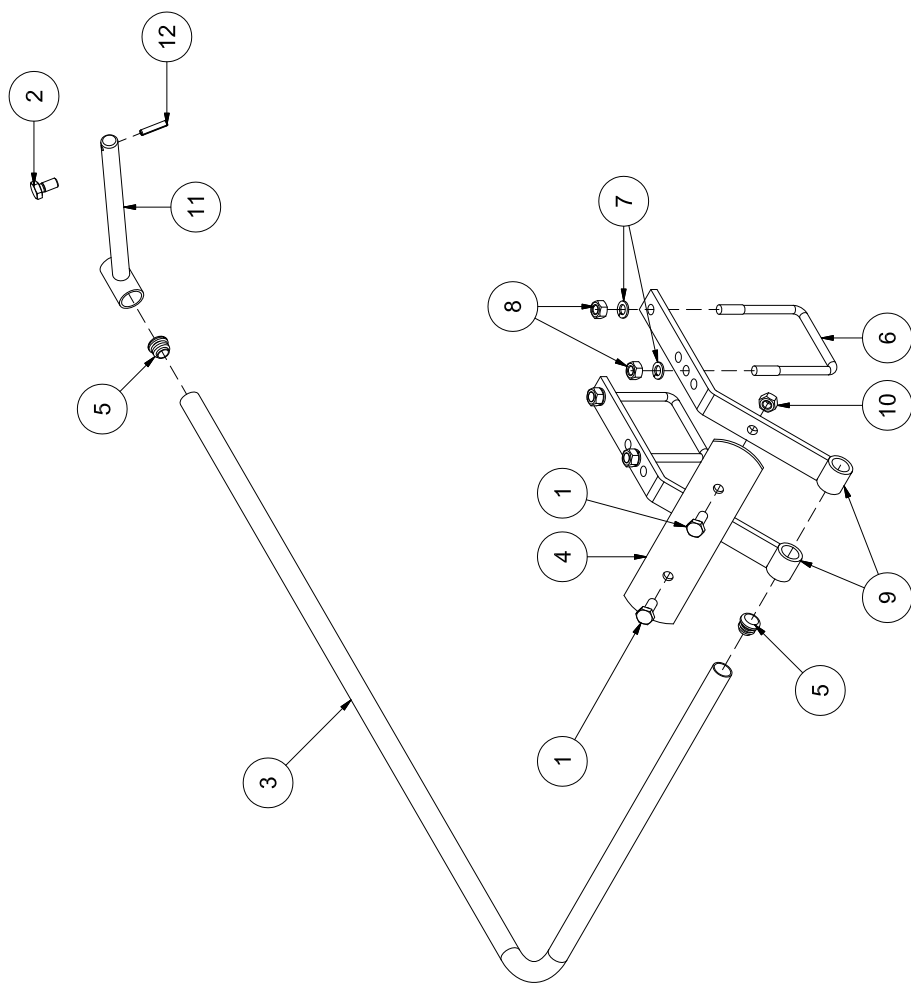

## Tav. 10

POS.	CODICE	DESCRIZIONE	QTÀ
1	0033176	VITE TE 10 X 25 Z 8.8 PG 5739-65	4
2	0006349	VITE M10x20 PG ZN UNI 5739	2
3		PROTEZIONE	2
	0035488	VERS. 155	
	0035488	VERS. 180	
	0035489	VERS. 205	
	0064319	VERS. 230	
4		LAMIERA DI PROTEZIONE	2
	0035491	VERS. 155	
	0035491	VERS. 180	
	0035492	VERS. 205	
	0035493	VERS. 230	
5	3178211	TAPPO D.22	4
6	0077450	CAVALLOTTO D. 10 CZ. 51021080	4
7	0001280	GROWER D. 10 Z C72 DIN 128 DACROMET	8
8	0001279	DADO D.10 6S PG UNI 5587 ZN	8
9	0064336	ATTACCO PER PROTEZIONE	4
10	0030156	DADO AUTOFREMANTE D. 10 PG	4
11	0037482	SUPPORTO	2
12	0015057	SPINA ELASTICA 6x30 Z C72 6873	2







macchine agricole

Via Labriola, 2 - 37054 NOGARA (Verona) - ITALY

Tel. 0442537411 r.a. - Fax 0442 537 444

Export: Tel. 0442 537 402

[www.breviglieri.com](http://www.breviglieri.com) - [info@breviglieri.com](mailto:info@breviglieri.com) - [export@breviglieri.com](mailto:export@breviglieri.com)