

MEGAMIXER

MOUNTING OPTIONS

- Skid-Steer Quick Attach
- Telehandler
- Pallet Forks

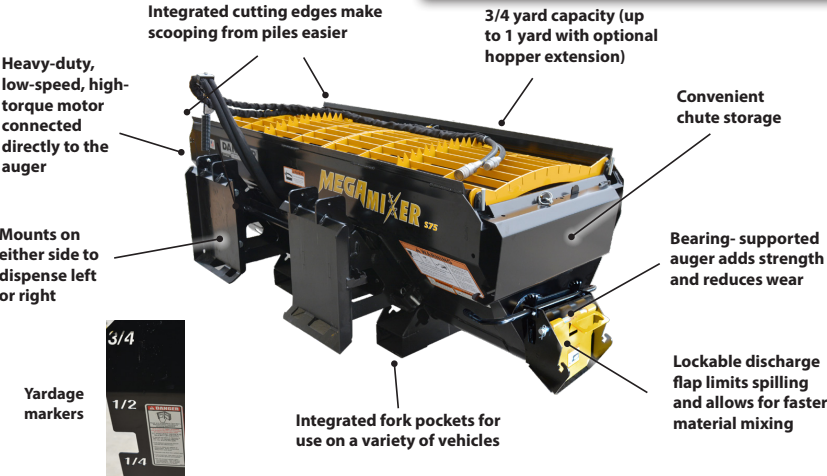

MATERIALS

- | | |
|---------------------|-------------|
| Concrete (1" Slump) | 1" Clean |
| Mortar | 1" Rock |
| Grout | Dry Topsoil |
| Asphalt | Sawdust |
| Livestock Feed | Compost |
| Sand | Manure |

AUGER All-Steel (S75)



DANUSER®



MEGA MIXER PRICE SHEET

1-Year Warranty

⚠ WARNING This product can expose you to chemicals known to the State of California to cause cancer and birth defects or other reproductive harm. For more information go to www.P65Warnings.ca.gov/product.

PN	DESCRIPTION	WT.	PRICE
170001	Mega Mixer S75 Includes two 24" chutes, hoses with flat face ISO couplers, built-in scraper blades, handle-operated automatic discharge flap, and safety grates with bag busters.	898	\$7,270.75

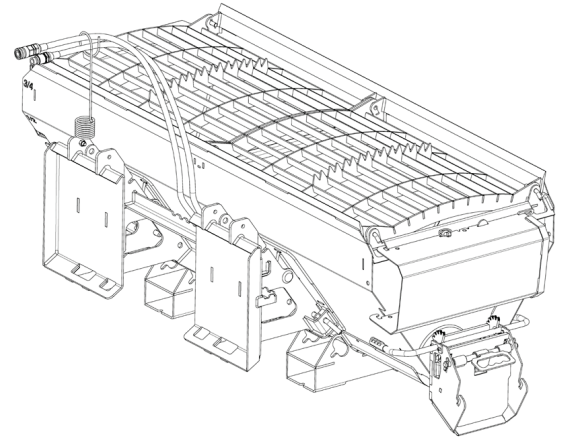

MEGA MIXER ACCESSORIES

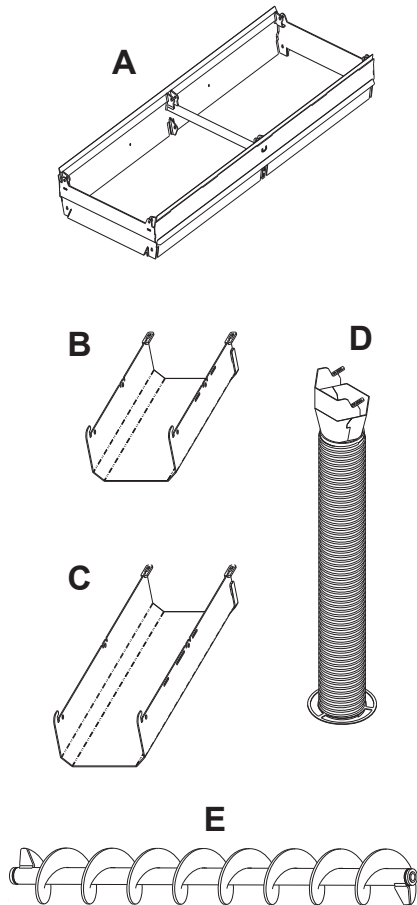

REF.	PN	DESCRIPTION	WT.	PRICE
A	170095	Hopper Extension Expands Mega Mixer capacity from 3/4 yard to 1 yard without modification. Hardware included. No tools required.	121	\$676.91
--	170100	24" Chute (SN 1280 & below) 2' chutes can be linked to extend.	15	\$67.31
--	170103	36" Chute (SN 1280 & below) 3' chutes can be linked to extend.	22	\$81.28
B	180700	24" Chute (SN 1281 & above) 2' chutes can be linked to extend.	15	\$67.31
C	180701	36" Chute (SN 1281 & above) 3' chutes can be linked to extend.	22	\$81.28
D	170110	Funnel with 6" Hose Adapter May be combined with 24" or 36" chute. Allows precision discharge with included 5' long, 6" diameter hose.	24	\$558.80
E	182050	Steel Auger Assembly	70	\$673.10
--	21231	Front-End Loader Hose Kit 1/2" hose kit, 25' long, with flat face ISO couplers and pioneer couplers. Bolt-on/weld-on mounting bracket included.	18	\$464.82

