

- NOTES: 1.) MAT'L - 1X2-1/2 FLAT 5160; HARDNESS - ROCKWELL C 42-46  
 2.) FINISH - CHASSIS GRAY (B)  
 3.) PART TO BE SHOT PEENED TO ALMEN C-7 MINIMUM IN AREA NOTED

DWG NO. 24354

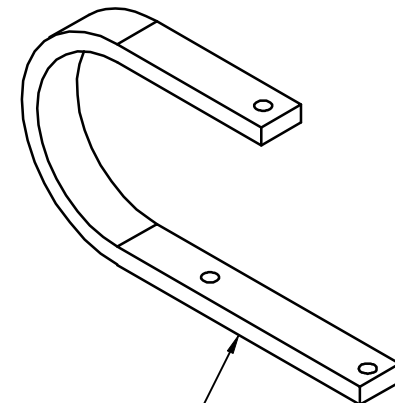
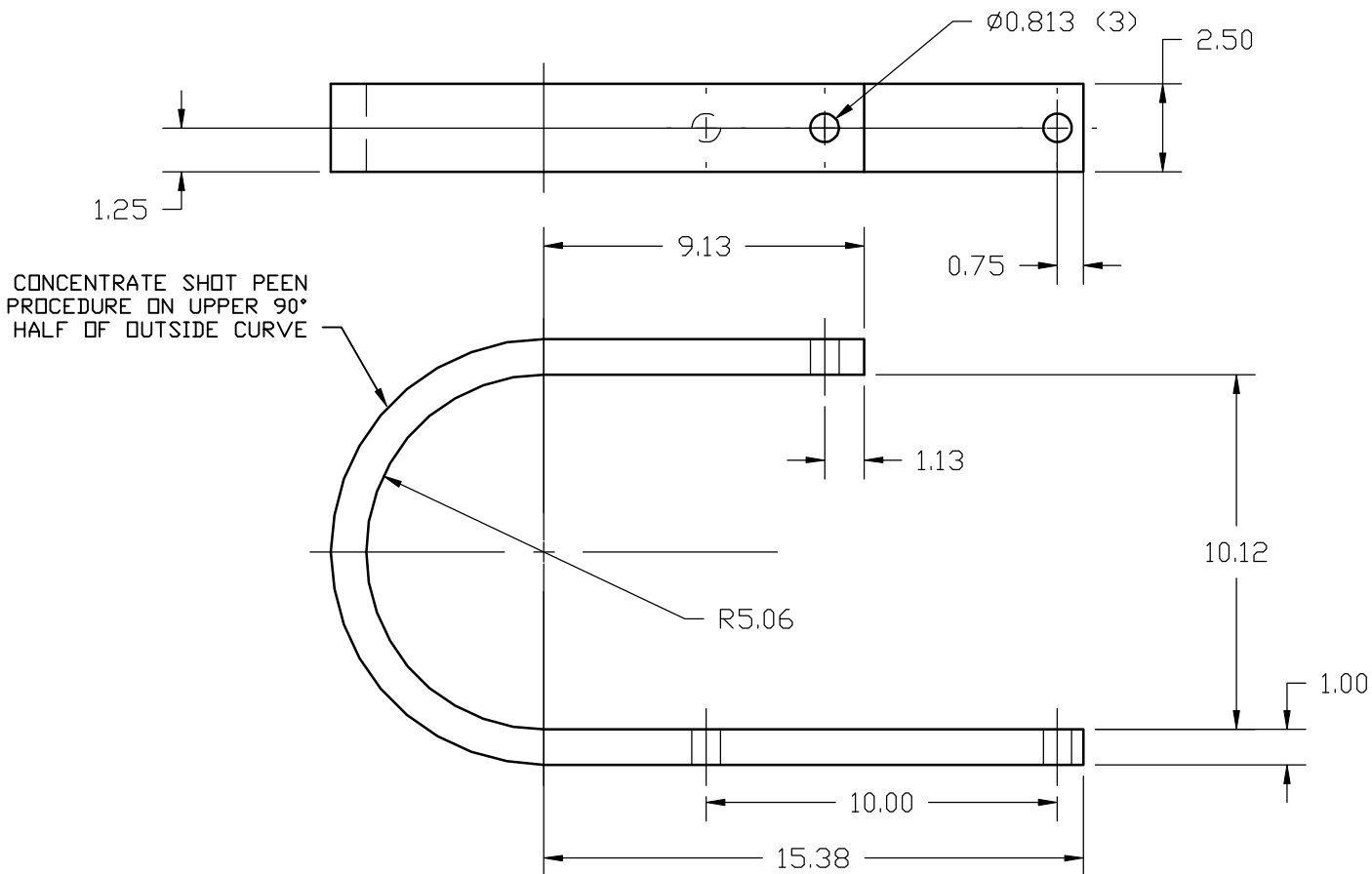

52603

				MATERIAL	PPP	( )	STD MIL TOL UNLESS SPEC.
				TOLERANCE UNLESS SPECIFIED DECIMAL: .X ±.06 [1,5] .XX ±.03 [0,8] .XXX ±.015 [0,38] HOLE DIA: -.005 +.015 [-0,13 +0,38] ANGLES: ±1.5° METRIC: [ ] DO NOT SCALE THIS DRAWING REMOVE ALL SHARP EDGES		WIL-RICH LLC	
051506	TLK	5-15	B	WAS PAINT BLACK		SPRING SHANK	
048512	ADM	4/85	A	RELEASE			
EO	BY	DATE	LTR	REVISION	ITEM CLS -	PREP	CHK
						ALR 8-17-05	ALR
						APVD	ALR
						SCALE	NONE
						DWG NO.	24354

TSC — NOTICE: WIL-RICH LLC claims proprietary rights to the information disclosed on this drawing. It is issued in confidence for engineering information only, and may not be reproduced or used to manufacture anything shown hereon without direct written permission from WIL-RICH LLC to the user.